

gorilla[®]

playsets



Woodbridge

ASSEMBLY MANUAL
Copyright © 2011 Gorilla Playsets
All Rights Reserved

Gorilla Playsets • 190 Etowah Industrial Court Canton, GA 30114
(800) 882-0272 • www.gorillaplaysets.com
Latest Revision: October 24, 2011

TABLE OF CONTENTS

Warranty and Safety Guidelines.....	Pages 4-11
Kit Contents and Tool List.....	Pages 11-31
Framing the play set.....	Steps 1-7
Constructing Deck and Upper Panel Boards.....	Steps 8-11
Constructing Rock Wall and securing to fort.....	Steps 12-16
Constructing and attaching Ladder.....	Steps 17-18
Installing Panel Slats.....	Steps 19-20
Installing Tic Tac Toe supports.....	Step 21
Assembling Swing.....	Steps 22-28
Assembling Roof and Upper Panel Slats.....	Steps 29-41
Attaching Tic Tac Toe Panel.....	Step 42
Assembling Sunburst.....	Steps 43-45
Securing supports then adding Picnic Table and Benches.....	Steps 46-50
Bottom Panel Slats.....	Step 51
Arched Side Top Panel Boards.....	Step 52
Installing Dormers and Chimney.....	Step 53
Installing Climbing Rope.....	Step 54
Attaching Accessories	Steps 55-61
<u>PART II</u> Clatter Bridge Assembly	Steps 1-31
Customer Registration Card.....	Last Page

**PLEASE READ OWNER'S MANUAL CAREFULLY
BEFORE STARTING ASSEMBLY!**

IMPORTANT – PLEASE READ

As fresh lumber acclimates to its new environment, the natural tendencies of the tree can show itself in the form of checks, or “cracks” in the lumber. In almost all cases this is normal and it will not affect the structural integrity of your play set.

Cosmetic defects that do not affect the structural integrity of the product, or natural defects of wood such as warping, checking or any other physical properties of wood that do not present a safety hazard, are not covered by this warranty. Defects that develop because the product is exposed to extreme climate conditions are not covered by this warranty. Defects that develop as a result of faulty or improper installation of the product are also not covered by this warranty.

Most cracks are not warrantable, however if you believe that the integrity of your play set is compromised by this natural occurrence, please follow the warranty claim procedure found at www.gorillaplaysets.com. Click on the “Customer Care” tab on the left hand side of the page, then click on “Warranty Claim” and follow the instructions.

We appreciate your purchase and know that you will enjoy your play system for many years to come.

IF YOU HAVE MISSING OR DAMAGED PARTS OR NEED ASSISTANCE ASSEMBLING, PLEASE CALL Gorilla Playsets™ MANUFACTURING DIRECT. (800) 882-0272 FACTORY HOURS – MON.–FRI., 8AM-5PM EST DO NOT RETURN THIS PRODUCT TO THE RETAILER OR CONTACT THE RETAILER DIRECT. THE RETAILER DOES NOT STOCK COMPONENTS. PLEASE RETAIN THESE INSTRUCTIONS FOR FUTURE REFERENCE. KEEP THEM IN A SAFE PLACE WHERE YOU CAN REFER TO THEM AS NEEDED.

CONTACT INFO:

Gorilla Playsets
190 Etowah Industrial Court
Canton, GA 30114
Tel. (800) 882-0272
Fax. (678) 880-3329
custsrv@gorillaplaysets.com

Check for revised instructions at www.gorillaplaysets.com/category-s/92.htm

Thank you for choosing Gorilla Playsets®

We've included everything you need, except tools, to build your very own professional looking play set. When complete, your new play set should far exceed the quality of play set kits from other build-your-own companies. Our engineers and design team have over 30 years of playground experience. What we've developed is a play set that doesn't compromise quality for simplicity. Yet you'll appreciate how quick and easy construction really is! Our play set kits are designed for children ages 3 to 11. Gorilla Playsets® believes every child should have a play set and with our kits they can! You can rest assured your new play set is safe, durable and designed to hold up to the elements. As parents ourselves, we know how important the security and well-being of our children is, and this shows in all of our products.

Each play set features our step-by-step 3D illustrated manual, patented powder coated swing beam bracket, heavy-duty swing belts with chains, slide(s), accessories, plus all the required hardware and pre-milled lumber.

Quality Lumber

At Gorilla Playsets, we use only the finest, hand selected lumber available. You can be assured that our lumber is strong, durable, and conforms to the national standards for use in children's play equipment. It's this quality that allows us to offer a 10 year warranty on the lumber used in our play sets.

Limited Manufacturers Warranty

Gorilla Playsets® (“Gorilla”) warrants its play sets to be free from defects in workmanship and materials, under normal use and conditions at its original installation, for 10 years for structural wood components and for one year for all other components (e.g., hardware, plastics, tarps, rope ladder, etc.) except Super Scoop Slides™ and Super Tube Spiral Slides™.

Gorilla warrants its Super Scoop Slides™ and Super Tube Spiral Slides™ to be free from defects in workmanship and materials, under normal use and conditions, for the lifetime of the product.

Cosmetic defects or natural defects of wood (e.g., warping, seasonal checking or cracking, knots, or knot holes, etc.) that do not affect the structural integrity of the product are not covered by this warranty. Defects that develop because the product is exposed to extreme climate conditions, excessive water exposure, lumber that has been damaged by wood boring bees, or defects that develop as a result of faulty or improper installation of the product, are not covered by this warranty. Fading, discoloration, or molding of any wood part or accessory, cracks in plastic components, surface rust on hardware, and chips on powder coated materials are not considered defects in material as long as they do not affect the functionality or structural integrity of the part or component.

It is the owner’s responsibility to properly maintain the play set. Instructions for proper maintenance can be found on Gorilla’s website. Imperfections or defects that develop because of a failure to properly maintain the play set are not covered by this warranty.

Gorilla will repair or, at its discretion, replace any part within the stated warranty period that is defective in workmanship or materials. This decision is subject to verification of the defect, which, at Gorilla’s discretion, may be accomplished by submitting photographs or by delivery of the defective part to Gorilla. Any warranty claim must include proof of purchase, including the date of purchase. In addition, within the first 30 days from the date of purchase, Gorilla will replace any parts discovered to be missing from or damaged in the original packaging.

This warranty is valid only if the product is used for the purpose for which it was designed and installed at a residential, single-family dwelling. This warranty is void if the product is used in a commercial or institutional setting. This warranty does not cover (a) products that have been damaged by acts of God, negligence, misuse, or accident, or that have been modified or repaired by unauthorized persons; (b) the cost of labor; or (c) the cost of shipping the product, any part, or any replacement product or part.

GORILLA DISCLAIMS ALL OTHER REPRESENTATIONS AND WARRANTIES OF ANY KIND, EXPRESSED, IMPLIED, STATUTORY, OR OTHERWISE, INCLUDING THE IMPLIED WARRANTIES OF MERCHANTABILITY AND FITNESS FOR A PARTICULAR PURPOSE. GORILLA WILL NOT BE LIABLE FOR ANY INCIDENTAL OR CONSEQUENTIAL DAMAGES. This warranty is valid only in the United States of America, is nontransferable and does not extend to the owners of the product subsequent to the original purchaser. Some states do not allow limitations on implied warranties or exclusion of incidental or consequential damages, so these restrictions may not be applicable to you. This warranty gives you specific legal rights. You may also have other rights which vary from state to state.

IMPORTANT SAFETY GUIDELINES

This product is intended for residential use only and not intended for use in any public setting. A safety surface such as mulch or recycled tire should be used under the play set to prevent injury from falls. Also a 6 foot safety zone should be used around the entire play set.

As with any home project, good judgment and respect for power tools will greatly reduce the risk of injury. Gorilla recommends you follow all tool manufacturers' safety guidelines. Always wear eye protection and safety gloves to prevent injury. In several phases of construction two people may be required for lifting and securing of lumber. While play set is being constructed, please keep children off the equipment until the project is complete. Bolts and screw heads should be checked regularly for tightness. The ground ladder, rope ladder, slide, swings and other areas where children spend a majority of their playtime should be checked more frequently.

Gorilla shall not be liable for incidental, indirect or consequential damages or injuries that result from the building and/or playing on our play sets. Adult supervision is recommended anytime a play set is being used.

WEIGHT LIMITS FOR GORILLA PLAYSETS

- FORT PLATFORMS: 800 LBS. TOTAL WEIGHT
- SWING BELTS: 225 LBS.
- GLIDER SWINGS: 70 LBS. PER CHILD. UP TO 140 LBS TOTAL.
- TRAPEZE: 125 LBS.
- FULL BUCKET SWING: 75 LBS.
- HALF BUCKET SWING: 75 LBS.
- INFANT SWING: 35 LBS.
- TIRE SWING: 125 LBS. TOTAL WEIGHT
- ROPE LADDER: 75 LBS.
- ROCK WALL: 150 LBS.
- RADICAL RIDE 5 SLIDE: 150 LBS.
- WAVE SLIDE: 150 LBS.
- CLATTER BRIDGE: 250 LBS.

Gorilla recommends that the weight limits for all components must not be exceeded. Failure to adhere to these and other safety guidelines could result in damage to the play set and injury to the users.

Safety and Maintenance Tips for Your New Play Set:

NOTE: Your children's safety is our #1 concern. Observing the following statements and warnings reduces the likelihood of serious or fatal injury. Please review these safety rules regularly with your children.

- This play set is designed for the use of 4 occupants who have a combined weight not exceeding 800 pounds on the elevated floor, 3 occupants who have a combined weight of 525 pounds on the swing area, for a total Unit capacity of 7 occupants who have a combined weight of 1325. (this weight is not including the picnic table area)
- On-site adult supervision is required.
- Teach children not to walk close to, in front of, behind, or between moving swings or other moving playground equipment.
- Teach children to sit in and never stand on swings
- Teach children not to twist the chains and ropes and not to loop them over the swing beam, since this may reduce the strength of the chain or rope.
- Teach children not to jump from swings or other playground equipment in motion.
- Teach children not to push empty seats. The seat may hit them and cause serious injury.
- Teach children to sit in the center of the swings with their full weight on the seats.
- Teach children not to use the equipment in a manner other than intended.
- Teach children to always go down slides feet first. Never slide headfirst.
- Teach children to look before they slide to make sure no one is at the bottom.
- Teach children to never run up a slide, as this increases their chances of falling.
- The parents should have the children dress appropriately with well-fitting shoes. Loose clothing such as scarves and ponchos should not be worn. Always take off, tie up or tuck in cords and drawstrings on children's clothing. These things can get caught on playground equipment and strangle a child.
- Teach children not to climb when the equipment is wet.
- Teach children to never jump from a fort deck. They should always use the ladder, ramp or slide.
- Teach children to never crawl or walk across the top of monkey bars.
- Teach children to never crawl on top of a fort roof.
- Verify that any suspended climbing ropes, chains, or cables are secured at both ends and that they cannot be looped around an adult hand.
- Teach children not to attach items to the playground equipment that are not specifically designed for use with the equipment, such as, but not limited to, jump ropes, clothesline, pet leashes, cables and chain as they may cause a strangulation hazard.
- Teach children to never wrap their legs around swing chain.
- Teach children to never slide down the swing chain.

WARNING: Children must NOT use this play set until unit has been completely assembled and inspected by an adult to insure set has been properly installed.

Safety and Maintenance Tips for Your New Play Set: (continued)

Playgrounds should be inspected on a regular basis. If any of the following conditions are noted, they should be removed, corrected, or repaired immediately to prevent injuries.

- Hardware that is loose, worn or that has protrusions or projections.
- Exposed equipment footings.
- Scattered debris, litter, rocks, or tree roots.
- Splinters, large cracks, and decayed wood components.
- Deterioration and corrosion on structural components, which connect to the ground
- Missing or damaged equipment components, such as handholds, guardrails, swing seats.
- Check all nuts and bolts frequently during the usage season and tighten as required. (But not so tight that you crack the wood) We recommend you check the swing beam and hardware often due to wood expansion and contraction. It is particularly important that this procedure be followed at the beginning of each season.
- Remove plastic swing seats and take indoors or do not use when the temperature drops below 32°F.
- Oil all metallic moving parts monthly during the usage period.
- Check all coverings for bolts and sharp edges twice monthly during usage season to be certain they are in place. Replace when necessary. It is especially important to do this at the beginning of each new season.
- Check swing seats, ropes, cables and chains monthly during usage season for evidence of deterioration. Replacement should be made of any swing seat that has developed cracks in the plastic seats. Ropes, cables and chains should be removed and replaced if excessive wear is found. Contact Gorilla for warranted replacement parts.
- For rusted areas on metallic members such as monkey bars, hand supports brackets, etc.; sand and repaint, using a non lead-based paint meeting the requirements of Title 16 CRF Part 1303.
- Inspect wood parts monthly. The grain of the wood sometimes will lift in the dry season causing splinters to appear. Light sanding may be necessary to maintain a safe playing environment. If you are treating your play set with stain regularly, it will help prevent severe checking/splitting and other weather damage.
- Once or twice a year, depending on your climate conditions, you must apply some type of protection (sealant) to the wood of your unit. Prior to the application of sealant, lightly sand any “rough” spots on your set. Please note this is a requirement of your warranty.
- Creating and maintaining the play set on a level location is very important. As your children play, your play set will slowly dig its way into the soil, and it is very important that it settles evenly. Make sure the play set is level and true once each year or at the beginning of each play season.
- Rake the play ground surface periodically to prevent compaction and maintain appropriate depths. Disposal Instructions: When the play set is no longer desired, it should be disassembled and disposed of in such away that no unreasonable hazards will exist at the time the unit is discarded.

Play Set Surfacing Recommendations:

Below are some of the recommendations that the U.S. Consumer Product Safety Commission (CPSC) offers from its Handbook for Public Playground Safety. The guide can be downloaded in full at www.cpsc.gov/cpscpub/pubs/325.pdf

1. Protective Surfacing - Since almost 60% of all injuries are caused by falls to the ground, protective surfacing under and around all playground equipment is the most critical safety factor on playgrounds.

Certain manufactured synthetic surfaces also are acceptable; however, test data on shock absorbing performance should be requested from the manufacturer.

Asphalt and concrete are unacceptable. They do not have any shock absorbing properties. Similarly, grass and turf should not be used. Their ability to absorb shock during a fall can be reduced considerably through wear and environmental conditions.

Certain loose-fill surfacing materials are acceptable. Surfacing materials are acceptable, such as the types and depths shown in the table.

Fall Heights and Materials

Type Of Material	6 in. depth	9 in. depth	12 in. depth
Double-Shredded bark mulch	6' Fall Height	10' Fall Height	11' Fall Height
Wood Chips	6' Fall Height	7' Fall Height	12' Fall Height
Fine Sand	5' Fall Height	5' Fall Height	9' Fall Height
Shredded Tires*	10-12' Fall Height	N/A	N/A
Fine Gravel	6' Fall Height	7' Fall Height	10' Fall Height

*This data is from tests conducted by independent testing laboratories on a 6-inch depth of uncompressed shredded tire samples produced by four manufacturers. The tests reported critical heights, which varied from 10 feet to greater than 12 feet. It is recommended that persons seeking to install shredded tires as a protective surface request test data from the supplier showing the critical height of the material when it was tested in accordance with ASTM F1292.

It should be recognized that all injuries due to falls cannot be prevented no matter what surfacing material is used.

2. Fall Zones - A fall zone, covered with a protective surfacing material, is essential under and around equipment where a child might fall. This area should be free of other equipment and obstacles onto which a child might fall. Stationary climbing equipment and slides should have a fall zone extending a Minimum of 6' in all directions from the perimeter of the equipment.

Swings should have a fall zone extending a minimum of 6' from the outer edge of the support structure on each side. The fall zone in front and back of the swing should extend out a minimum distance of twice the height of the swing as measured from the ground to the top of the swing support structure.

LEVELING YOUR FORT DURING ASSEMBLY

- Complete the steps which will be the basic frame of the fort {i.e. four corner posts with base (sand box boards) and deck supports}
- Position in the most level area chosen for the play set, keeping in mind the location and size of the swing beam, ladder, slides, etc. that extend off the fort.
- Once the frame is in the final position, check for vertical and horizontal levelness to determine which side(s) will need to be dug into the ground to level the play set.
- With a shovel, score the ground around the outside edges of the sandbox boards on the 'high' side of the fort. This is the area that will be dug in. Make sure to score deep enough; the scored lines will be your digging template.
- Push the frame off and away from the scored area, far enough to dig and remove dirt to reach the appropriate depth.
- Dig a channel along the scored line(s) for the base of the fort (corner post and sandbox boards) to rest into. Dig the channel(s) to the same level depth. The bottom of the channel(s) should be level to each other so your frame doesn't teeter or rock because the channel(s) are uneven.
- Once you have removed enough grass and dirt, slide/push the frame into the channel(s). Place a level on the vertical and horizontal boards of the frame to determine if enough soil, or too much, was removed.
- Repeat this process until the basic frame is plumb and level and in its final position before completing the rest of the assembly.
- Measure to make sure fort is square.

Important: if you require a channel depth of more than 6", then we recommend you have your play set area professionally graded before completing assembly.

Example Play area:

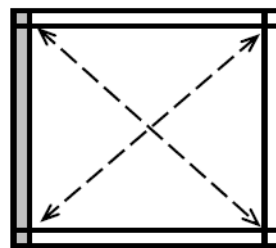
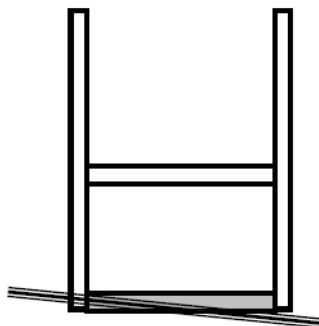

The diagonal measurements should be the same from corner post to corner post. If not, adjust corner posts so that the distance is equal.

■ = Area to be scored and channeled for levelness

General Info to Review Before Installation

- Depending on your experience, assembly of Gorilla Playsets can take as little as 6 hours up to 24 hours, depending on size, after inventory of parts; therefore, we recommend you set aside a full two days for assembly.
- Identify all of the parts for your play set. Empty each box and lay out boards so you can see each part. Your instruction book will have detailed drawings that will make it easy for you to recognize individual parts. Keep all hardware and metal parts separate from wooden pieces.
- After everything is laid out, check carefully to ensure all parts are present. Make sure there are no broken boards.
- Find an area to sort your hardware. It is best to open the hardware on a solid surface so that you do not lose any pieces in the grass. This will save time and familiarize you with all the different pieces in the hardware bag.
- Important note: Wood has some natural defects such as knots, surface cracks, etc... We reject parts that are structurally defective. We use a high quality lumber in our structures; however, you should inspect each part for splinters or rough spots and sand them smooth to prevent injury.
- After familiarizing yourself with all of the components, read all instructions thoroughly. Reading instructions after you have studied the parts will help you understand more clearly the installation process, and help to eliminate unnecessary mistakes.
- Pay close attention to the diameter and length of each bolt and screw.
- Never tighten hardware completely at first. It helps to have some adjustment for bolt alignment while you are attaching parts together. After everything is square, tighten each joint.
- After the main unit is assembled it is critical that the floor is level and square. If the main frame is not level, the walls and floor will be out of square.
- After you complete installation, make sure every bolt, screw, and nut is tight, and every board is secure. Wood will expand and contract with the seasons.
- Check all bolt connections and swing hangers every two weeks.
- Place the set on level ground, not less than 6ft from any structure or obstruction such as a fence, garage, house, overhanging branches, laundry lines, or electrical wires.

This page is a list of definitions and explanations used throughout our instructions to aid you in the assembly of your play set.

Offset Holes- Throughout the installation procedures we will refer to parts with offset holes. This refers to the orientation of the holes on the board. An offset hole is one that is closer to one side than it is the other or in other words, it is not centered on the board. In the procedures you will be instructed to attach the boards with the holes offset up or with the holes offset down. This refers to which side of the board the hole/holes should be closer to. Offset holes up= hole/holes will be closer to the top of the board. Offset holes down= hole/holes will be closer to the bottom of the board. Note: some parts do not have offset holes, but instead the holes are on center. Therefore there will not be any reference to how to offset these parts.

EXAMPLE OF OFFSET HOLES UP



EXAMPLE OF OFFSET HOLES DOWN



Counter-sunk holes- Many of the parts that will be used have counter-sunk holes. A counter-sunk hole is one that surrounds one side of a thru hole, but does not extend through the wood it's self. When using a counter-sunk hole the bolt will be inserted through the thru hole and either the head of the bolt and washer or nut and washer will occupy the counter sunk hole.

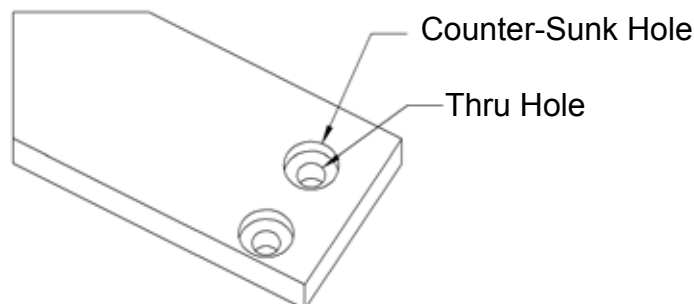

Lag Screws- Lag screws are used in the construction of our play sets to enhance the structural integrity of the unit. There will not be predrilled holes in the post for lag screw installation. Lag screws are self-tapping, though if you are using a manual socket wrench it may be necessary to tap the head of the lag screw with a hammer. You should also be sure to tighten the lags completely. Power tools such as an impact wrench or power drill should have enough torque to drive the lag screws without using a hammer, but make sure not to over tighten as this can cause the threads to “strip out” in the post.

Common Installation Practice Installing T-nuts

When installing T-nuts into the wood, use a smooth faced hammer to set the face of the T-nut flush into the wood

Corner Post

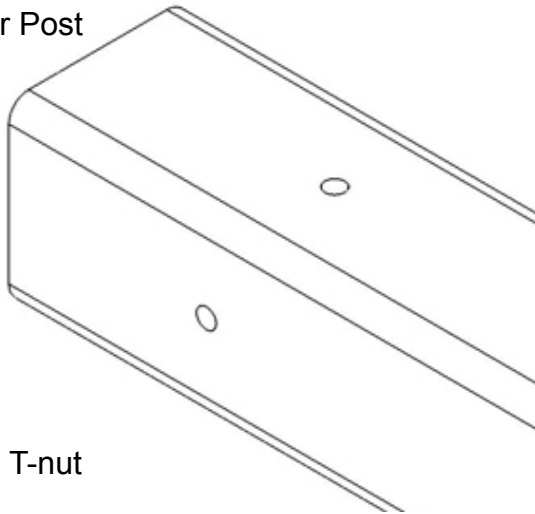

T-nut

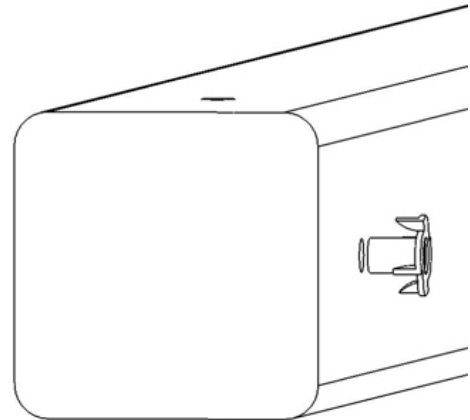

Insert the barrel of the T-nut into the predrilled hole. Using a smooth faced hammer, drive the T-nut until the face of the T-nut is flush to the wood.

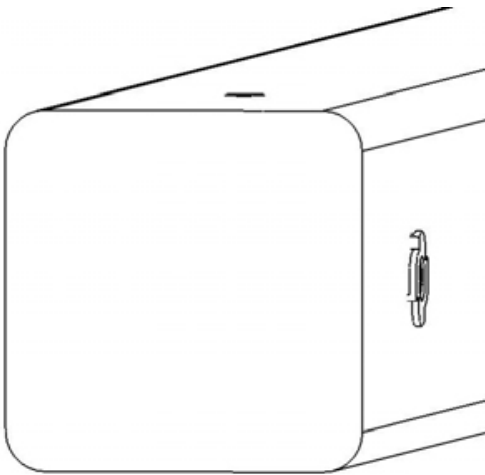

This picture shows the T-nut insert and installed flush to the wood.

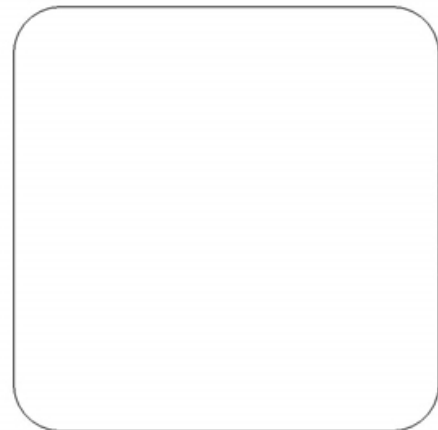

This picture shows an end view of the T-nut insert and installed flush to the wood.

WARNING: DO NOT EMBED THE TOP OF THE T-NUT INTO THE FACE OF THE WOOD.

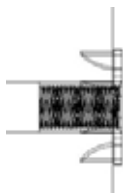

Cross Section end views, you are looking at an Xray view of the post and T-nut. The barrel of the T-nut is in the corner post the line is the face of the wood.

Please familiarize yourself with the manual, parts/components and general construction process of your new playset before getting started.

SITE PLAN:

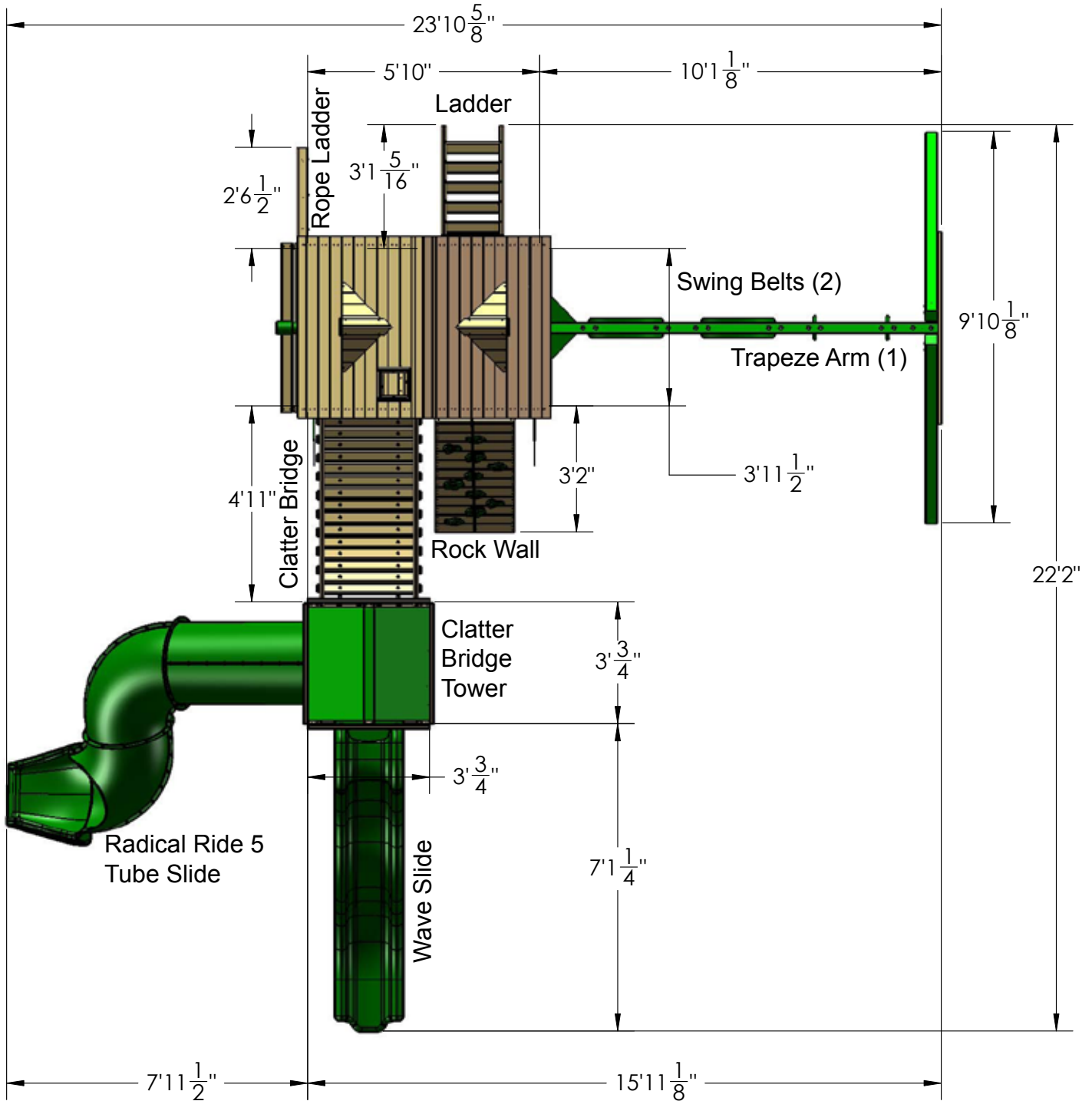

Playset height: 12' 3-1/2" , Height of Clatter bridge Tower 9' 9-1/4"
 Deck height: 4' 9-1/2", Swing Beam Height 7' 7-3/8"

Approximate assembly time: Approximately 16 hours.

(6) foot unobstructed safety perimeter around playset recommended

REQUIRED TOOL LIST:

- ___ Standard or Cordless Drill w/ Phillips Bit (#2 square bit provided)
- ___ 1/8" Drill Bit
- ___ 3/8" Drill Bit
- ___ 1" Spade/Paddle Bit
- ___ 1/2" Wrench and Socket
- ___ 1/2" Deep Well Socket
- ___ 9/16" Deep Well Socket
- ___ 9/16" Wrench and Socket
- ___ Level
- ___ Tape Measure
- ___ Extension Cord (if using standard drill)
- ___ Hammer
- ___ Pencil
- ___ Locking Pliers (Vise Grips)
- ___ Shovel

KIT CONTENTS

Swings, Slides, Accessories:

- ___ (Qty) Description
- ___ (2) Swingbelts w/ Chains
- ___ (1) 10ft. Wave Slide
- ___ (1) Rope Ladder
- ___ (1) Tic Tac Toe Panel
- ___ (1) Assembly Manual
- ___ (10) Rock Wall Grips (assorted colors)
- ___ (1) Trapeze Swing
- ___ (1) Telescope
- ___ (1) Steering Wheel
- ___ (2) Safety Handles
- ___ (1) Flag Kit (1 pair)
- ___ (1) 10 ft Rope
- ___ (2) 96" sections of chain
- ___ (1) Radical Ride 5 Tube Slide
- ___ (1) 802 Tarp

Fort and Swing Beam Hardware:

See following pages and pages 96-98 in PART II Clatter Bridge.

Wood Components:

See following pages and pages 96-98 in PART II Clatter Bridge.

READ! VERY IMPORTANT!

If you are missing parts or have questions regarding the installation of our quality product PLEASE call us directly at the factory **(1-800-882-0272)**. Our trained staff will be happy to assist you.

Customer service hours:
Monday thru Friday 8AM – 5PM EST
E-mail: custsrv@gorillaplaysets.com



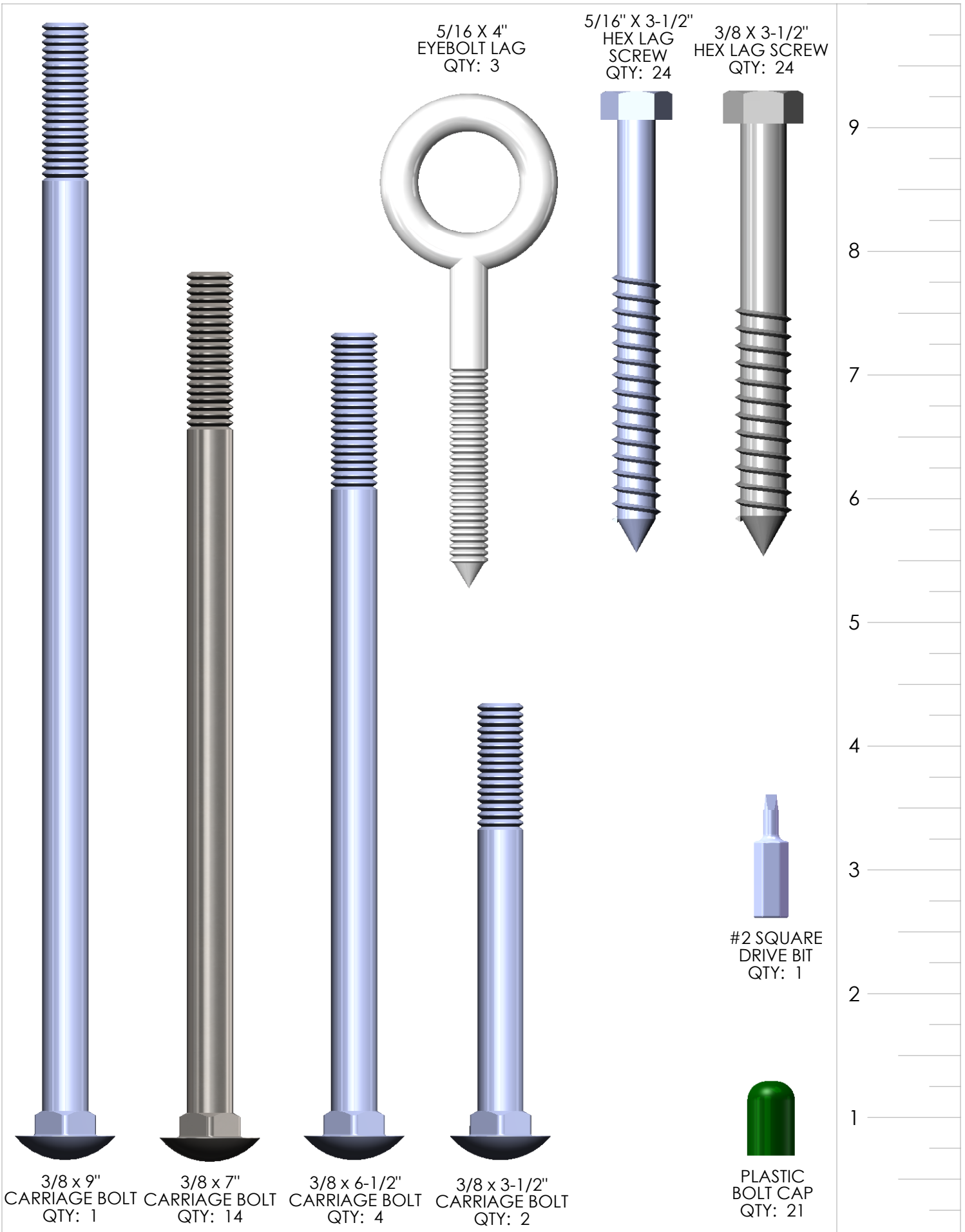

USE THE RULER TO THE RIGHT TO MEASURE YOUR BOLTS AND SCREWS. PICTURE VIEWS SHOWN ABOVE ARE 1:1 SCALE AND CAN BE USED TO MATCH BOLT AND SCREW SIZES.

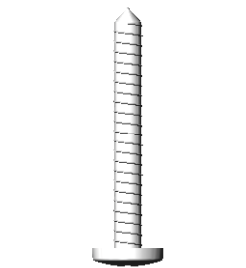

#14 X 1-1/4"
PAN HEAD SCREW
QTY: 16

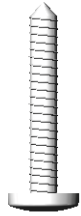

#14 x 1"
PAN HEAD SCREW
QTY: 4

#8 X 1"
WOOD SCREW
QTY: 8



#8 X 1-1/4"
WOOD SCREW
QTY: 16



#8 X 1-1/2"
WOOD SCREW
QTY: 390

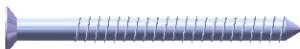

#8 X 2"
WOOD SCREW
QTY: 165

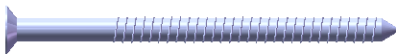

#8 X 2-1/2"
WOOD SCREW
QTY: 83

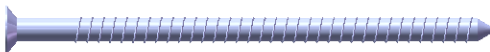

#8 X 3"
WOOD SCREW
QTY: 12

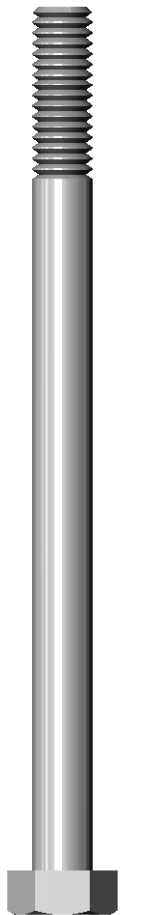
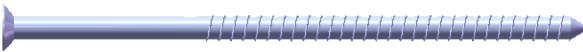

5/16 X 4-1/2"
HEX BOLT
QTY: 28



5/16 X 1-1/2"
HEX BOLT
QTY: 8



5/16" TEE NUT
QTY: 36



TORQUE WASHER
QTY: 19



3/8" LOCK NUT
QTY: 21







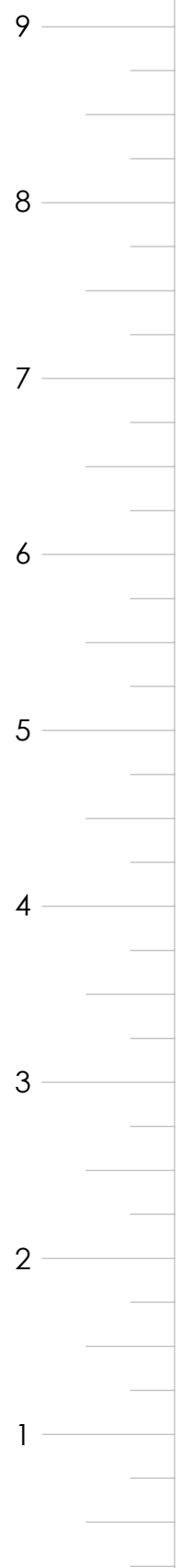

3/8" WASHER
QTY: 45



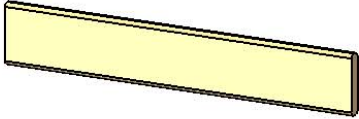
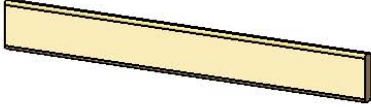
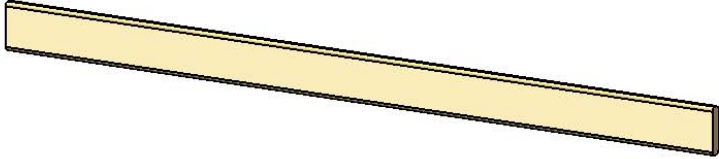
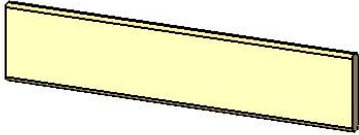

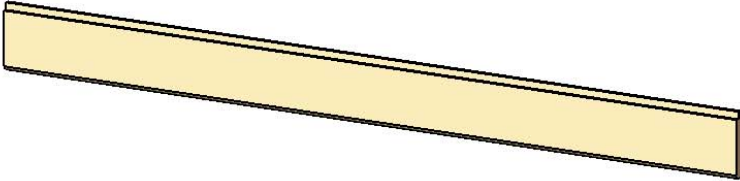
5/16" WASHER
QTY: 60

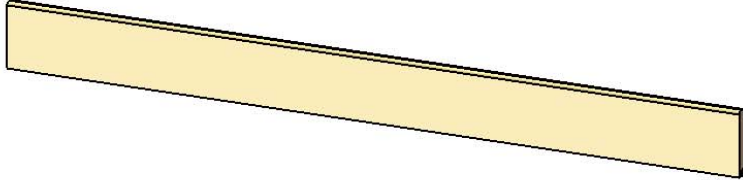

USE THE RULER TO THE RIGHT TO MEASURE YOUR BOLTS AND SCREWS. PICTURE VIEWS SHOWN ABOVE ARE 1:1 SCALE AND CAN BE USED TO MATCH BOLT AND SCREW SIZES.

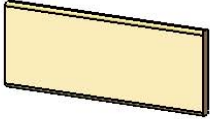
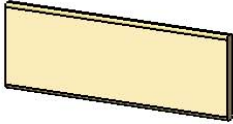
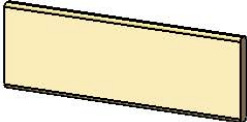
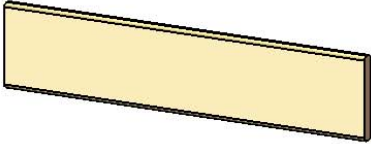
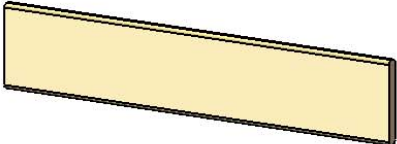
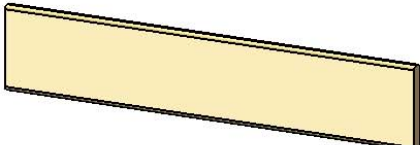
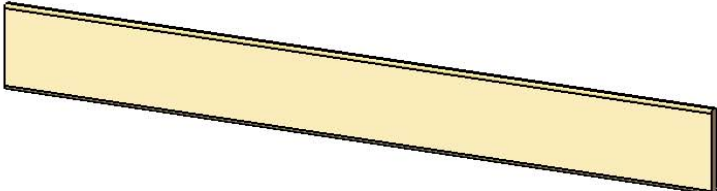
PICTURE	DESCRIPTION	QTY.	
	1 X 4 X 25" PANEL SLAT 1-4-2500-PS	2	
	1 X 4 X 26" FRONT PANEL SLAT 1-4-2600-FPS	2	
	1 X 4 X 51" REAR PANEL SLAT 1-4-5100-RPS	2	
	1 X 5 X 25" PANEL SLAT 1-5-2500-PS	1	
		1 X 5 X 55" ROOF FINISHER 1-5-5500-RF	2
		1 X 5 X 55" ROOF STARTER 1-5-5500-RS	2
	1 X 6 X 4-1/2" BOTTOM WINDOW SUPPORT 1-6-0450-BWS	6	

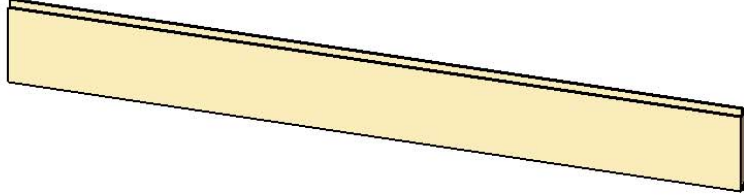
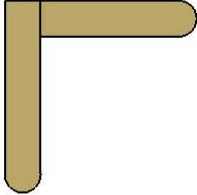
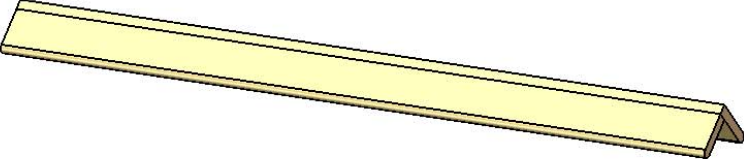
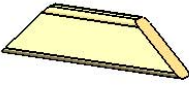
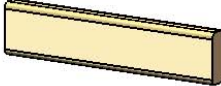
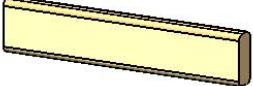
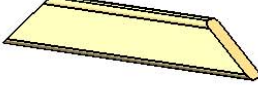
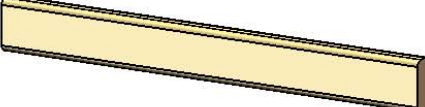

PICTURE	DESCRIPTION	QTY.
	1 X 6 X 14-1/4" FRONT PANEL SLAT 1-6-1425-FPS	8
	1 X 6 X 16" TIC TAC TOE SUPPORT 1-6-1600-TTTS	2
	1 X 6 X 17" PANEL SLAT 1-6-1700-PS	15
	1 X 6 X 26" FRONT PANEL SLAT 1-6-2600-FPS	8
	1 X 6 X 27-3/4" PANEL SLAT 1-6-2775-PS	11
	1 X 6 X 29-1/2" BOTTOM WINDOW SUPPORT 1-6-2950-BWS	2
	1 X 6 X 51" REAR PANEL SLAT 1-6-5100-RPS	4

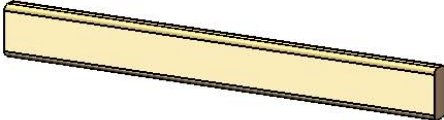
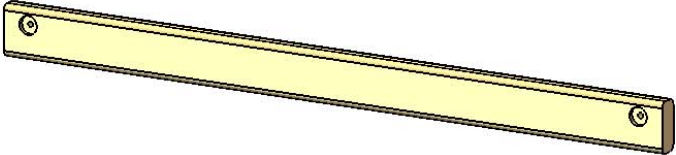
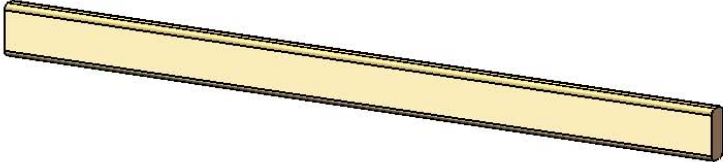
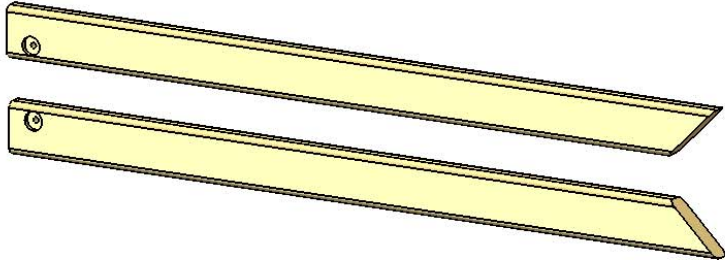
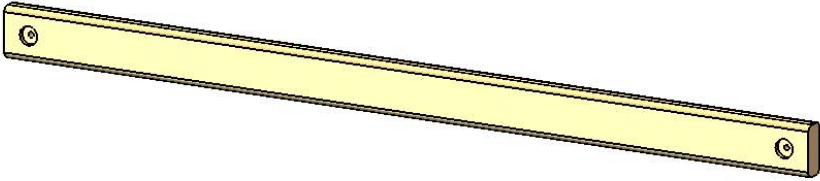
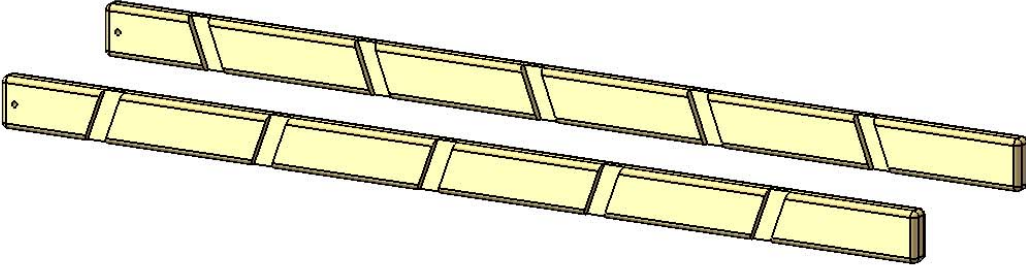
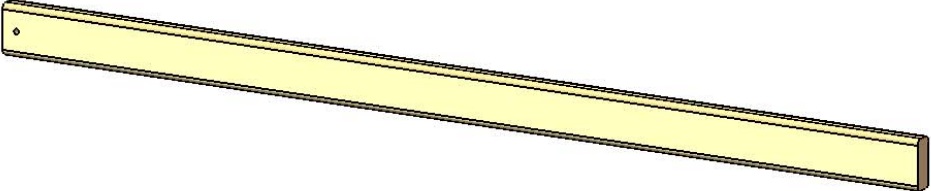

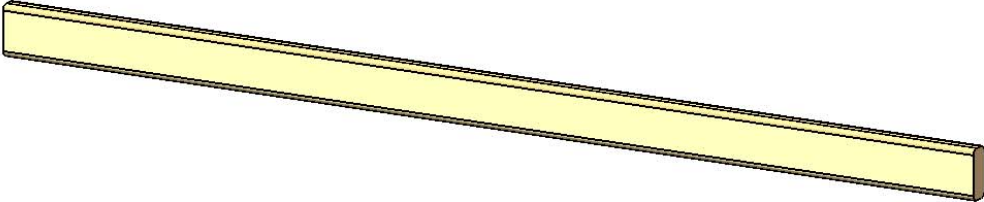
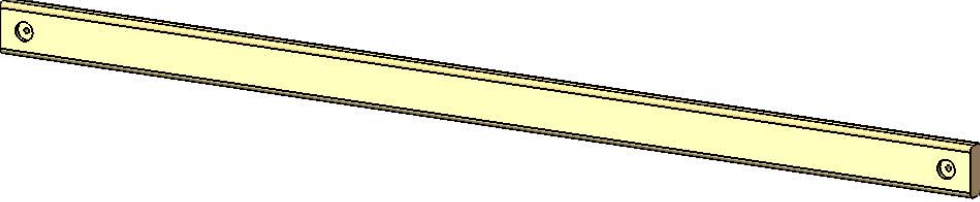
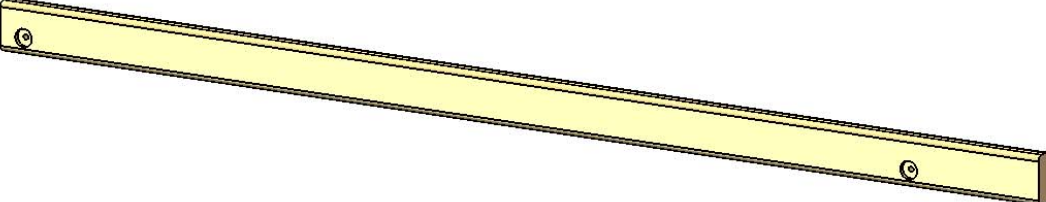
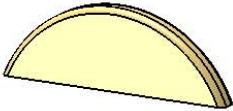
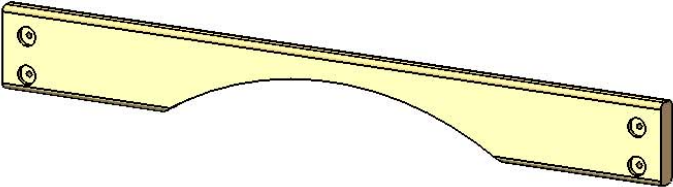
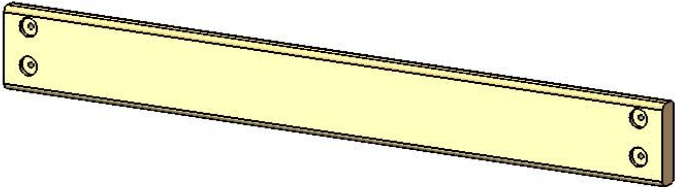
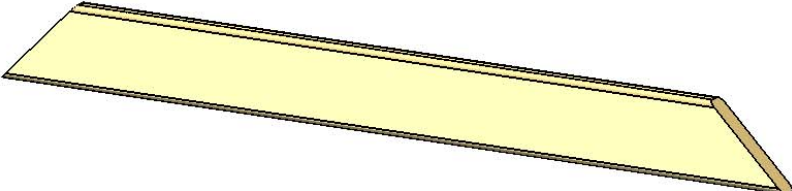
PICTURE	DESCRIPTION	QTY.
 	<p>1 X 6 X 55" ROOF BOARD</p> <p>1-6-5500-RB</p>	<p>18</p>
 	<p>55" ROOF PEAK</p> <p>1-6-5500-RP</p>	<p>1</p>
	<p>2 X 4 X 13" ANGLE SUPPORT</p> <p>2-4-1300-AS</p>	<p>4</p>
	<p>2 X 4 X 15" PICNIC TABLE SUPPORT</p> <p>2-4-1500-PTS</p>	<p>2</p>
	<p>2 X 4 X 17" LADDER STEP</p> <p>2-4-1700-LS</p>	<p>5</p>
	<p>2 X 4 X 18" ANGLE SUPPORT</p> <p>2-4-1800-AS</p>	<p>4</p>
	<p>2 X 4 X 30" PICNIC TABLE VERTICAL SUPPORT</p> <p>2-4-3000-PTVS</p>	<p>2</p>

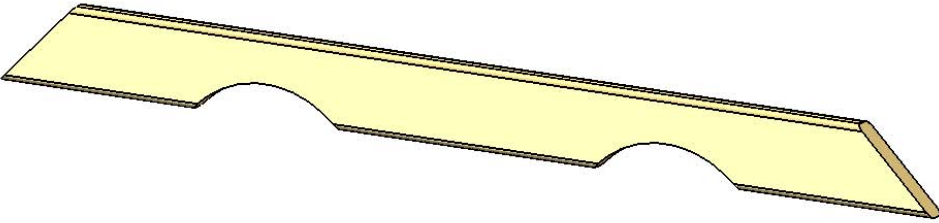
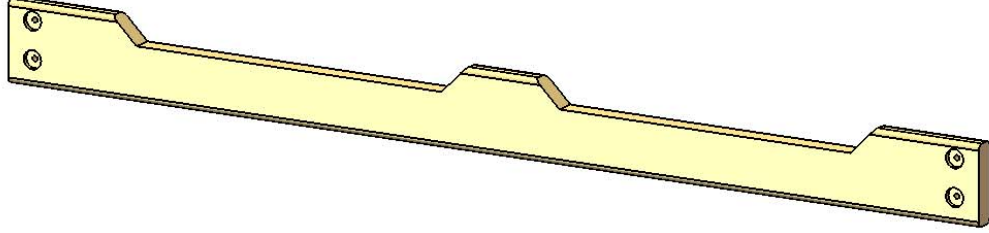
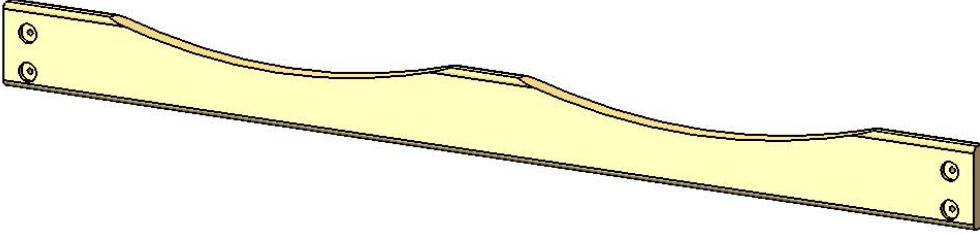
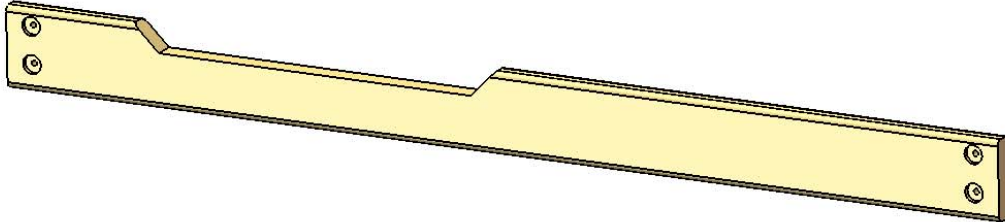
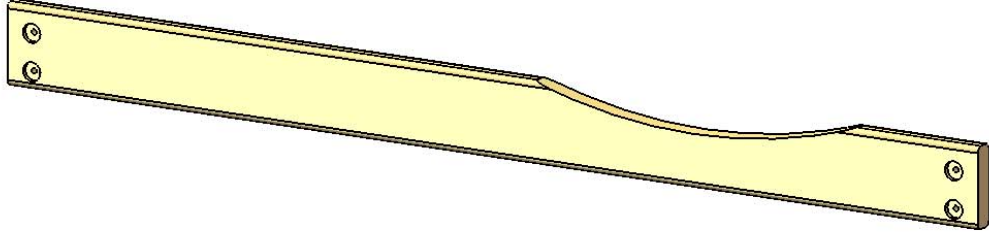
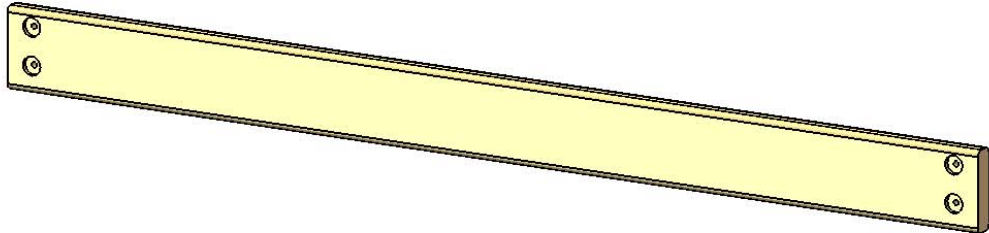
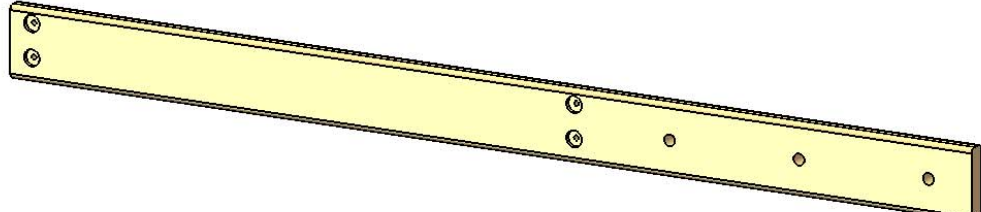
PICTURE	DESCRIPTION	QTY.
	2 X 4 X 31" BENCH SUPPORT 2-4-3100-BS	1
	2 X 4 X 47-1/2" SAFETY/END PANEL BOARD 2-4-4750-SBEP	3
	2 X 4 X 51" PICNIC TABLE SEATS AND TOP 2-4-5100-PTST	7
	2 X 4 X 51" ROOF SUPPORT LEFT AND RIGHT 2-4-5100-RSL 2-4-5100-RSR	2 LEFT 2 RIGHT
	2 X 4 X 58" SWING BEAM CROSS MEMBER 2-4-5800-CM	1
	2 X 4 X 66" LADDER LEFT AND RIGHT SIDES 2-4-6600-LLS 2-4-6600-LRS	1 LEFT 1 RIGHT
	2 X 4 X 66" ROCK WALL SIDE 2-4-6600-RWS	2

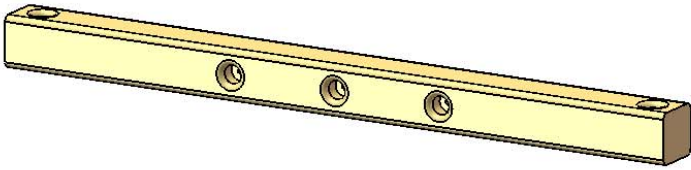
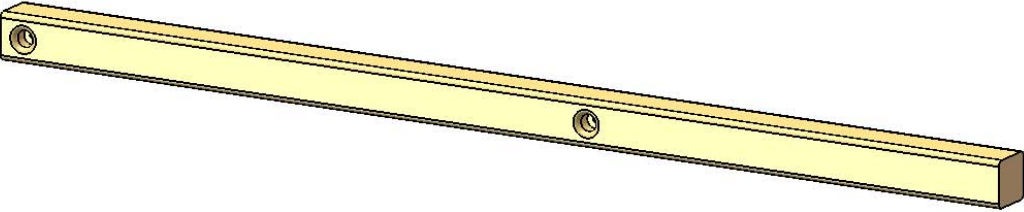
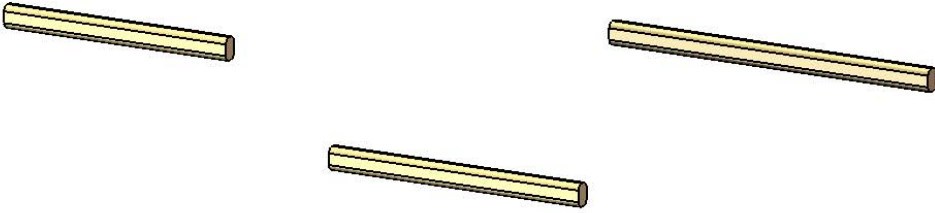
PICTURE	DESCRIPTION	QTY.
	<p>2 X 4 X 70" CENTER DECK SUPPORT</p> <p>2-4-7000-CDS</p>	<p>1</p>
	<p>2 X 4 X 70" DECK SUPPORT</p> <p>2-4-7000-DS</p>	<p>2</p>
	<p>2 X 4 X 78" PANEL SUPPORT</p> <p>2-4-7800-PS</p>	<p>1</p>
	<p>2 X 6 X 16" SUN</p> <p>2-6-1600-S</p>	<p>2</p>
	<p>2 X 6 X 47-1/2" ARCHED SIDE TOP BOARD</p> <p>2-6-4750-ASTB</p>	<p>2</p>
	<p>2 X 6 X 47-1/2" END SANDBOX - PANEL BOARD</p> <p>2-6-4750-ESPB</p>	<p>3</p>
	<p>2 X 6 X 56-1/2" SUNBURST BOARD</p> <p>2-6-5650-SB</p>	<p>2</p>

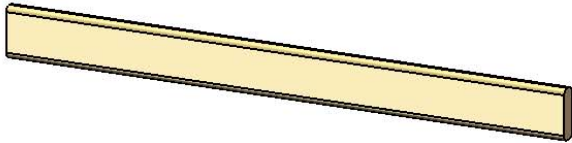
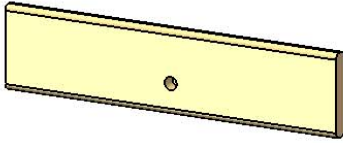
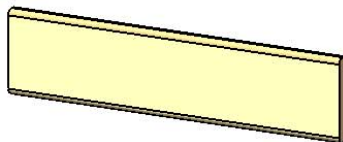
PICTURE	DESCRIPTION	QTY.
	<p>2 X 6 X 67-1/4" SUNBURST BOARD</p> <p>2-6-6725-SB</p>	<p>2</p>
	<p>2 X 6 X 70" FRONT FACE BOARD</p> <p>2-6-7000-FFB</p>	<p>1</p>
	<p>2 X 6 X 70" FRONT TOP PANEL BOARD</p> <p>2-6-7000-FTPB</p>	<p>1</p>
	<p>2 X 6 X 70" REAR FACE BOARD</p> <p>2-6-7000-RFB</p>	<p>1</p>
	<p>2 X 6 X 70" REAR TOP PANEL BOARD</p> <p>2-6-7000-RPTB</p>	<p>1</p>
	<p>2 X 6 X 70" SANDBOX BOARD</p> <p>2-6-7000-SB</p>	<p>2</p>
	<p>2 X 6 X 78" ROPE LADDER RUNNER</p> <p>2-6-7800-RLR</p>	<p>1</p>

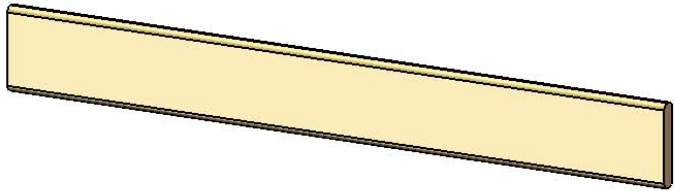
PICTURE	DESCRIPTION	QTY.
	<p>4 X 4 X 47-1/2" SWING BEAM MOUNT</p> <p>4-4-4750-SBM</p>	<p>1</p>
	<p>4 X 4 X 78" ROPE LADDER SUPPORT</p> <p>4-4-7800-RLS</p>	<p>1</p>
	<p>5/4 X 2 X 16" SMALL RAY 125-2-1600-SR</p> <p>5/4 X 2 X 18" SMALL RAY 125-2-1800-SR</p> <p>5/4 X 2 X 23" LARGE RAY 125-2-2300-LR</p>	<p>4</p> <p>4</p> <p>2</p>
	<p>5/4 X 3 X 18-3/4" LADDER BACK 125-3-1875-LB</p> <p>5/4 X 3 X 23-7/8" ROCK WALL CAP 125-3-2387-RWC</p>	<p>1</p> <p>1</p>
	<p>5/4 X 4 X 40-1/4" DECK SPACER 125-4-4025-DS</p>	<p>2</p>
	<p>5/4 X 6 X 23-7/8" BOTTOM ROCK WALL BOARD 125-6-2387-BRW</p>	<p>1</p>
	<p>5/4 X 6 X 23-7/8" ROCK WALL BOARD 125-6-2387-RWB</p>	<p>11</p>

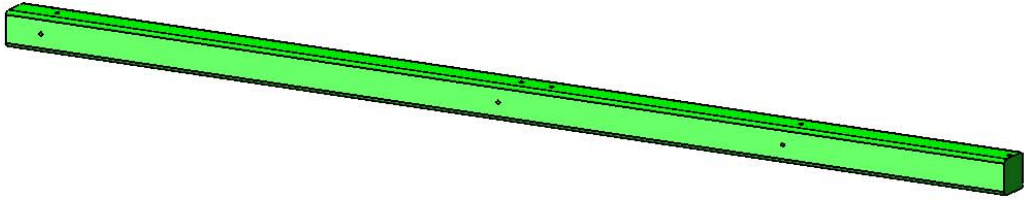
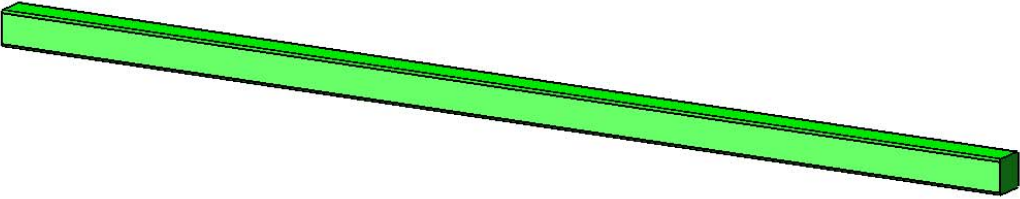
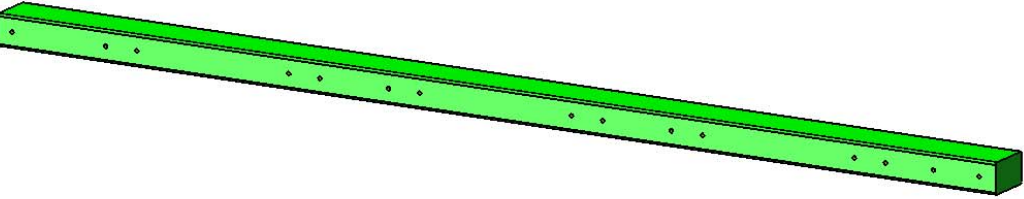
PICTURE	DESCRIPTION	QTY.
	<p>5/4 X 6 X 47-3/8" DECK BOARD</p> <p>125-6-4737-DB</p>	<p>11</p>
	<p>5/4 X 6 X 10" ROOF PEAK SUPPORT</p> <p>125-6-1000-RPS</p>	<p>2</p>
	<p>4 X 4 X 108" PLASTIC COATED CORNER POST</p>	<p>4</p>
	<p>4 X 4 X 108" PLASTIC COATED SWING LEG</p>	<p>2</p>
	<p>4 X 6 X 120" PLASTIC COATED SWING BEAM</p>	<p>1</p>
		<p>25</p>

PICTURE

DESCRIPTION

QTY.



RADICAL
RIDE 5
TUBE
SLIDE

1



10'
EXTREME
WAVE
SLIDE

1

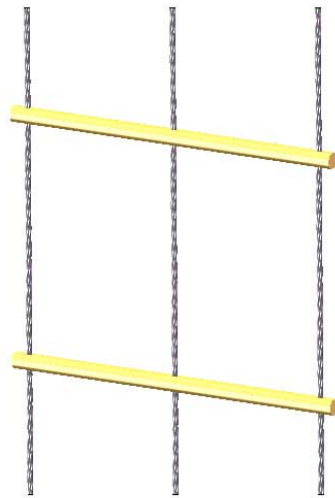

ROPE
LADDER
ASSEMBLY

1



SWINGS
W/CHAINS

2



TRAPEZE
BAR
W/CHAINS

1

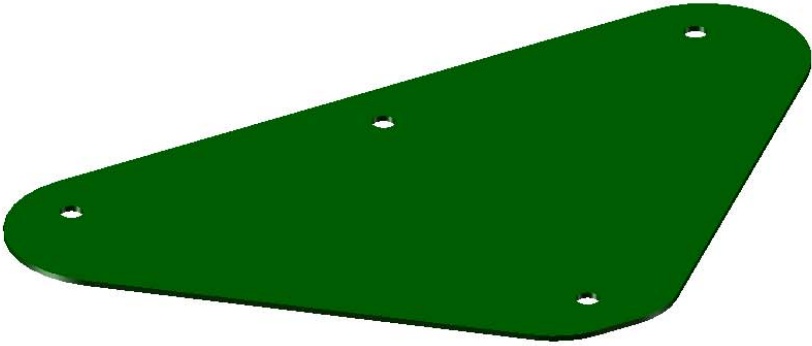
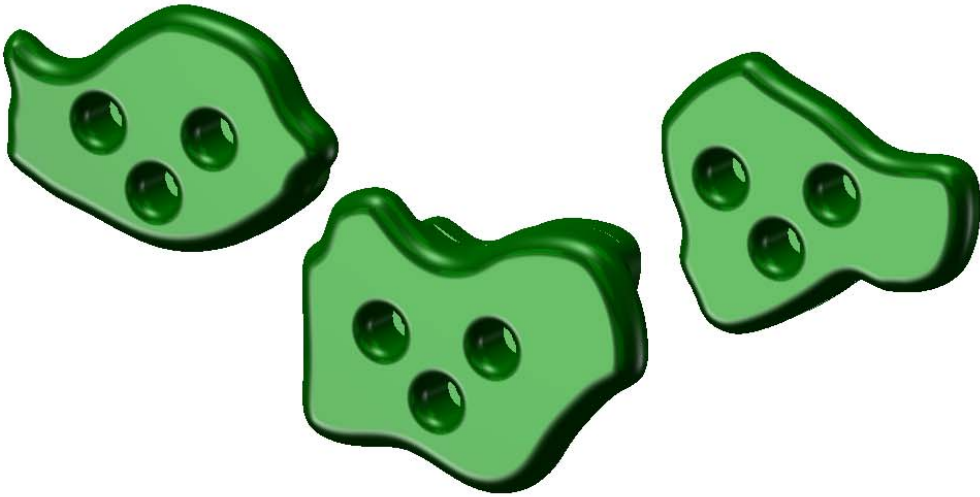
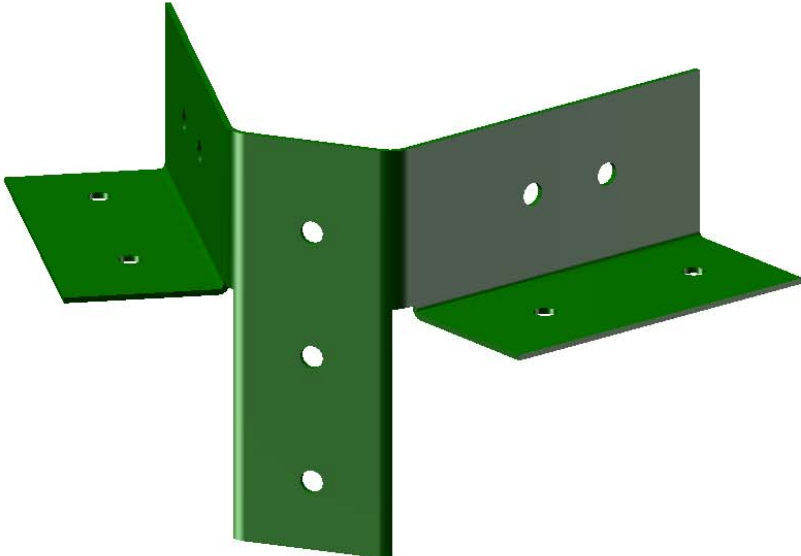
PICTURE	DESCRIPTION	QTY.
	<p>SWING PLATE</p>	<p>1</p>
	<p>CLIMBING ROCKS</p>	<p>10</p>
	<p>A-FRAME SWING LEG BRACKET</p>	<p>1</p>
<p>NOT SHOWN</p>	<p>HARDWARE BOX INSTRUCTIONS</p>	<p>1 EA.</p>

PICTURE

DESCRIPTION

QTY.

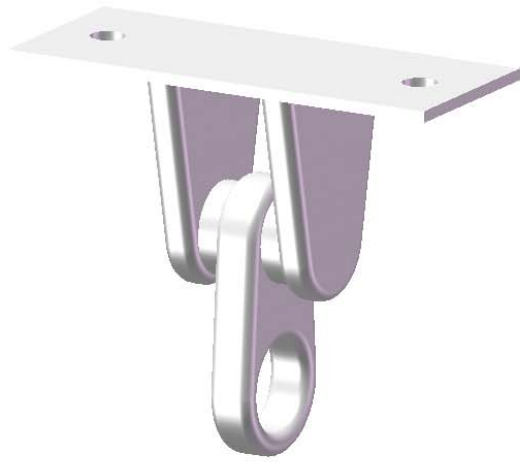

IRON
DUCTILE
SWING
HANGERS

6

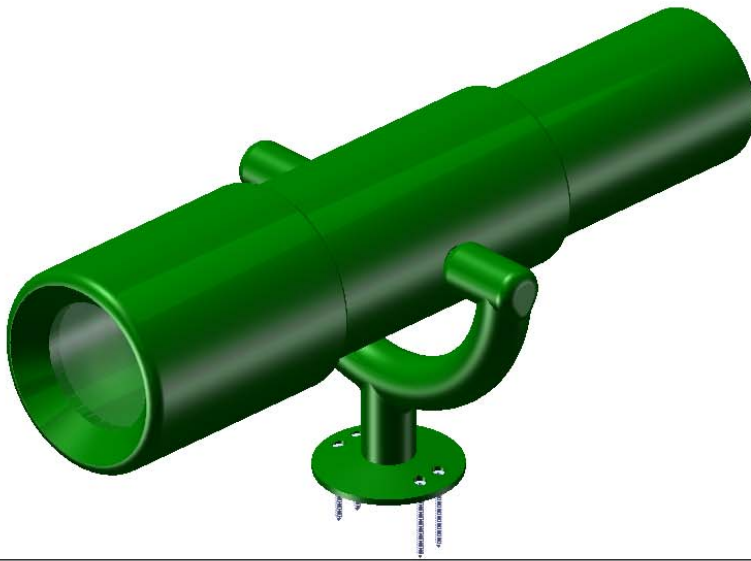

TELESCOPE

1

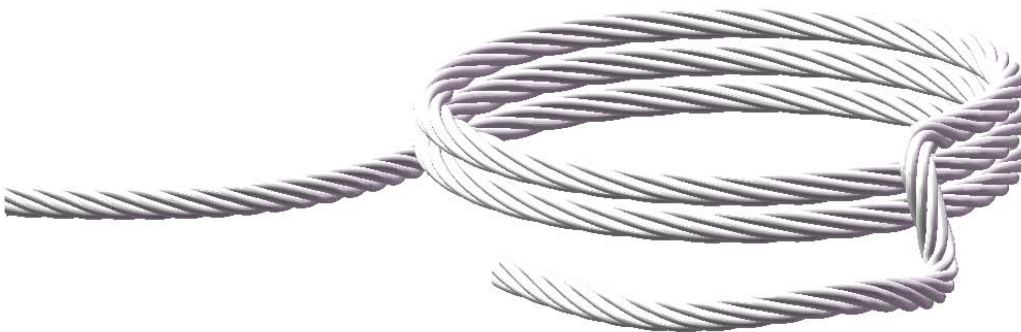

10' ROPE

1

PICTURE

DESCRIPTION

QTY.



90° GREEN
BRACKET

4



SPRING
CLAMP

6

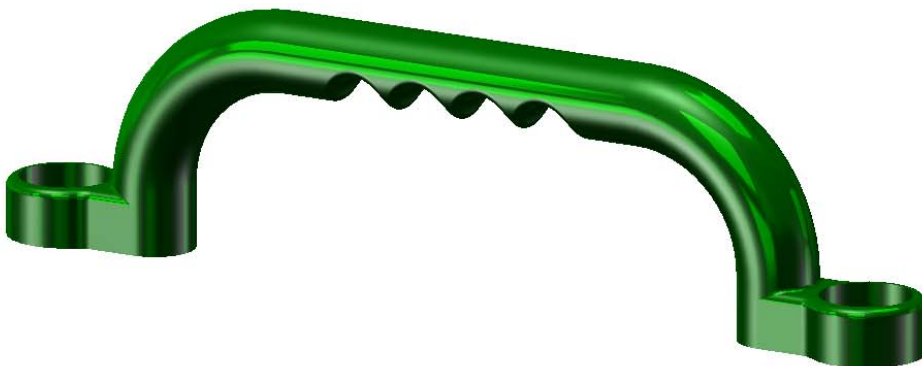

SAFETY
HANDLES
(PAIR)

1

PICTURE

DESCRIPTION

QTY.

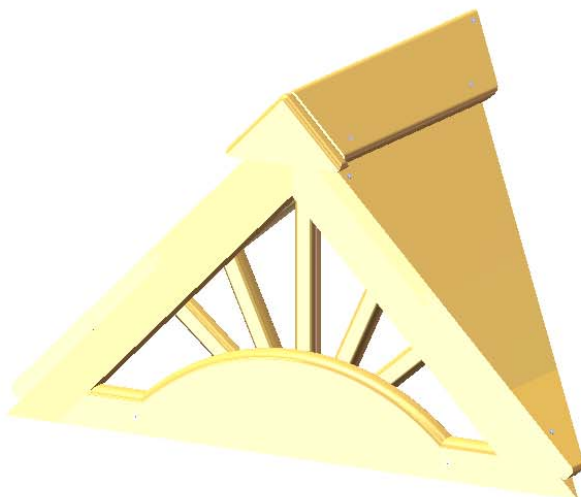
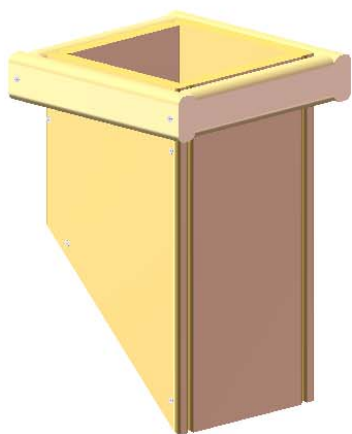

UNASSEMBLED
CHIMNEY

1

UNASSEMBLED
DORMER

2



BOXED
TIC-TAC-TOE
SPINNER
PANEL

1

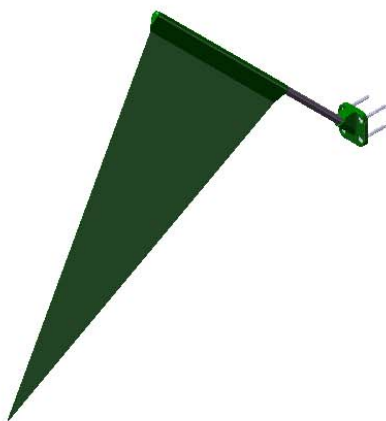

FLAG KIT

1

PICTURE

DESCRIPTION

QTY.



WINDOW
PANEL

4

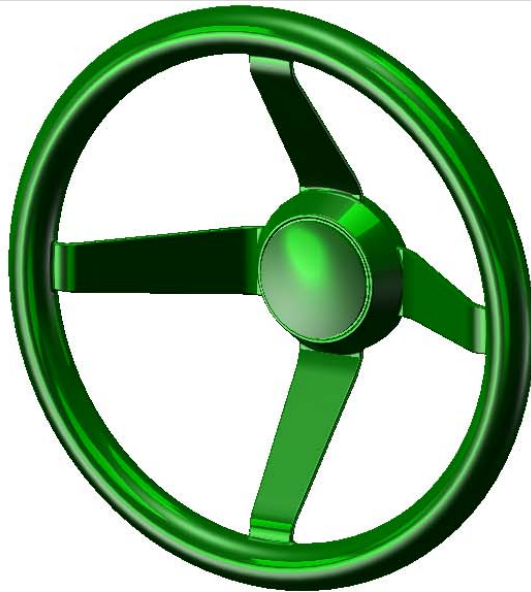

STEERING
WHEEL

1

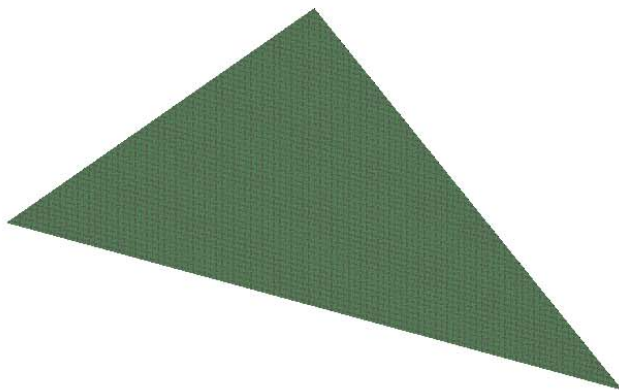

SUNBURST
SCREEN

2

STEP 1: ATTACHING THE T-NUTS TO THE CORNER POSTS

1: THIS STEP IS CRITICAL TO BUILDING THE PLAY SET PROPERLY. IF ANY MISTAKES ARE MADE HERE, YOU WILL NEED TO DISASSEMBLE THEN REASSEMBLE TO MAKE YOUR CORRECTIONS. MAKE SURE HOLES ARE FREE OF ANY OBSTRUCTIONS. USE A BOLT TO CLEAN OUT ANY DEBRIS.

2: LAY OUT EACH OF THE 4 X 4 X 108" CORNER POSTS IN THE AREA YOU INTEND ON BUILDING THE PLAYSET.

3: USE THE DIAGRAM BELOW TO CORRECTLY IDENTIFY AND ORIENT THE NECESSARY DIRECTION THE POSTS SHOULD FACE.

4: USE A HAMMER TO SEAT THE T-NUTS AFTER INSERTING THEM INTO THE HOLES SHOWN IN THE DIAGRAM BELOW.

5: THE BARREL OF THE T-NUT SHOULD GO INTO THE HOLE FIRST. HAMMER THE T-NUT UNTIL IT IS FLUSH/ALMOST FLUSH TO THE CORNER POSTS.

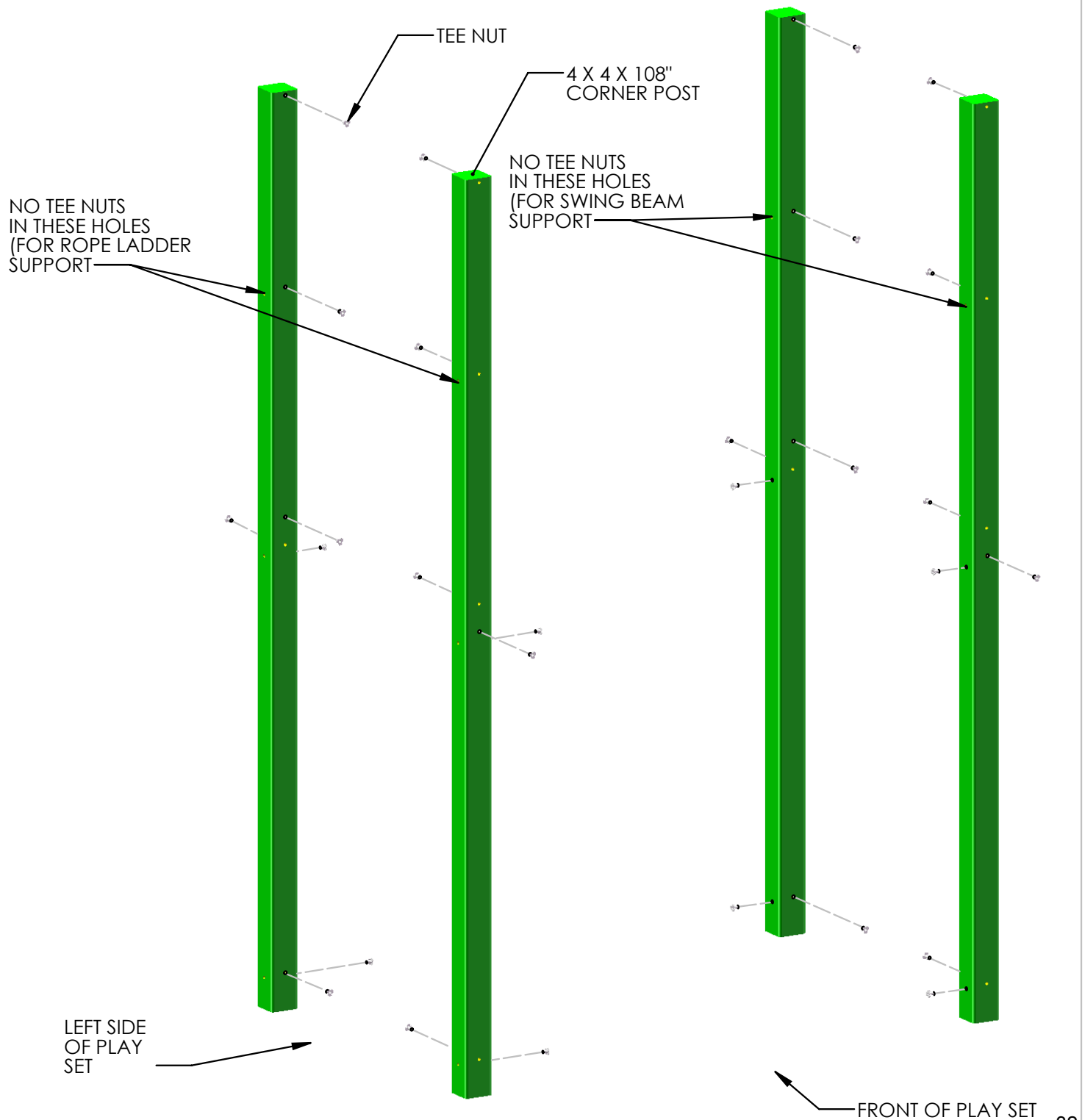

STEP 2: ASSEMBLING THE LEFT SIDE FRAME

- 1: LAY THE LEFT SIDE CORNER POSTS ON THE GROUND IN THEIR PROPER ORIENTATION.
- 2: LAY THE 2 X 6 X 78" ROPE LADDER RUNNER ON TOP OF THE LEFT SIDE CORNER POSTS AT THE BOTTOM OF THE CORNER POSTS. THE OFFSET HOLES IN THE SANDBOX BOARD MUST FACE DOWNWARD.
- 3: USE 5/16 X 4-1/2" HEX BOLTS AND 5/16" WASHERS TO ATTACH THE TOP HOLES OF THE SANDBOX BOARD TO THE T-NUTS INSTALLED ON THE CORNER POSTS. THE BOTTOM HOLES WILL BE USED LATER.
- 4: LAY THE 2 X 6 X 47-1/2" BOTTOM PANEL BOARD ON TOP OF THE LEFT SIDE CORNER POSTS IN THE MIDDLE OF THE CORNER POSTS. THE OFFSET HOLES IN THE BOTTOM PANEL BOARD MUST FACE DOWNWARD.
- 5: USE 5/16 X 4-1/2" HEX BOLTS AND 5/16" WASHERS TO ATTACH THE BOTTOM HOLES OF THE BOTTOM PANEL BOARD TO THE T-NUTS INSTALLED ON THE CORNER POSTS. THE TOP HOLES WILL BE USED LATER.
- 6: LAY THE 4 X 4 X 78" ROPE LADDER SUPPORT ON TOP OF THE LEFT SIDE CORNER POSTS.
- 7: FIND TWO TORQUE WASHERS. PLACE A 3/8" X 6-1/2" CARRIAGE BOLT INSIDE THE TORQUE WASHER, MAKING SURE THAT THE TEETH ARE FACING IN THE SAME DIRECTION AS THE THREADS OF THE CARRIAGE BOLT. PLACE THE TORQUE WASHER/CARRIAGE BOLT ASSEMBLY INTO THE HOLES OF THE CORNER POST SO THAT THE HEAD OF THE CARRIAGE BOLT FACES WHAT WILL BE THE INSIDE OF THE FORT. USE A HAMMER TO SET THE TORQUE WASHER INTO THE CORNER POST. ATTACH THE TOP HOLES OF THE ROPE LADDER SUPPORT TO THE T-NUTS INSTALLED ON THE CORNER POSTS.
- 8: ATTACH THE ROPE LADDER SUPPORT AS SHOWN IN DETAIL A.

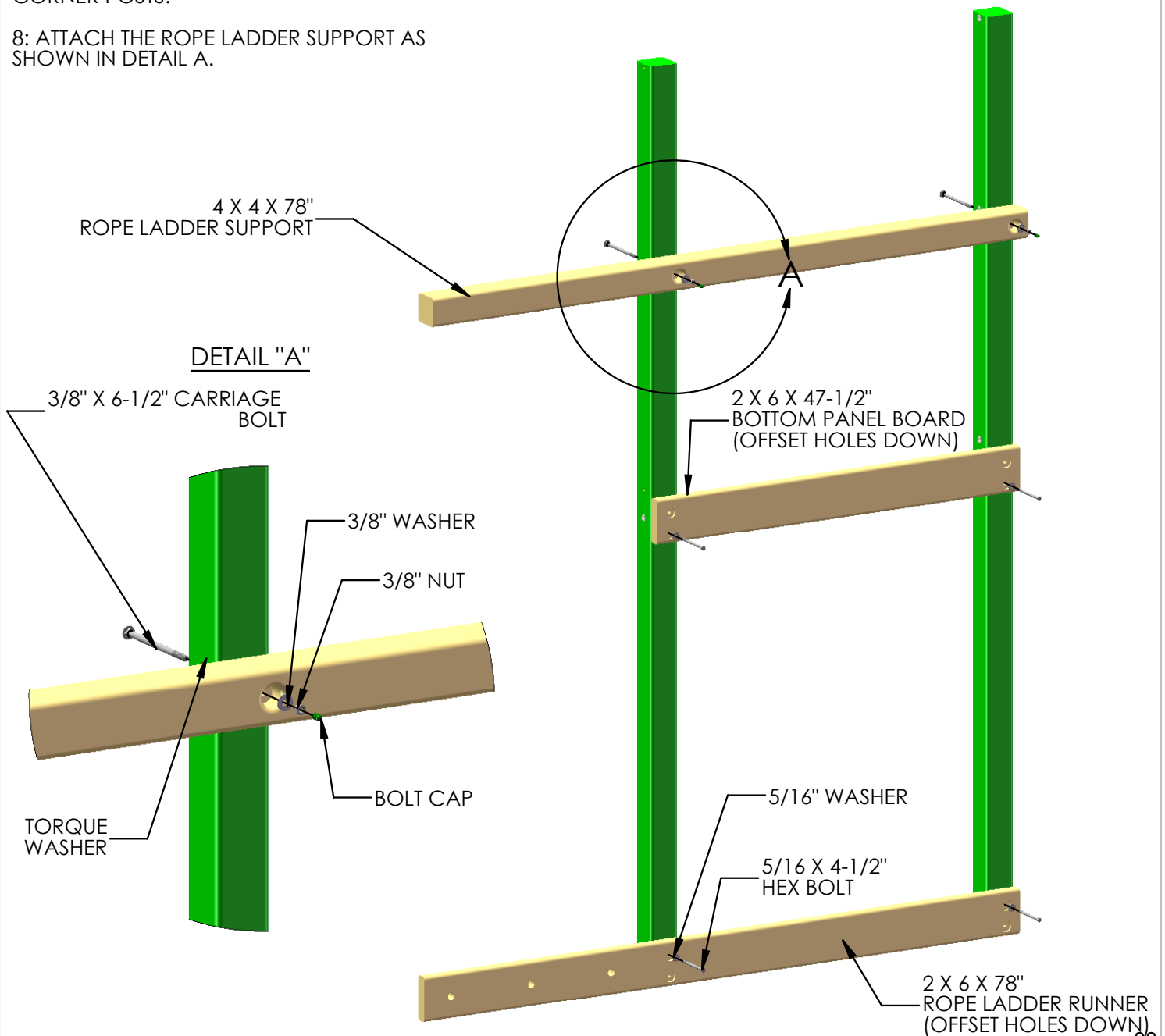

STEP 3A: DRILL HOLES FOR BRIDGE CHAINS

1: LOCATE ONE 2 X 4 X 70" DECK SUPPORT AND ONE 2 X 6 X 70" FRONT FACE BOARD.

2: MEASURE AS SHOWN BELOW AND MAKE MARKS ON EACH BOARD.

3: PLACE A SCRAP PIECE OF WOOD UNDER THE BOARD BEFORE YOU DRILL THE 1" HOLES WITH A SPADE BIT.

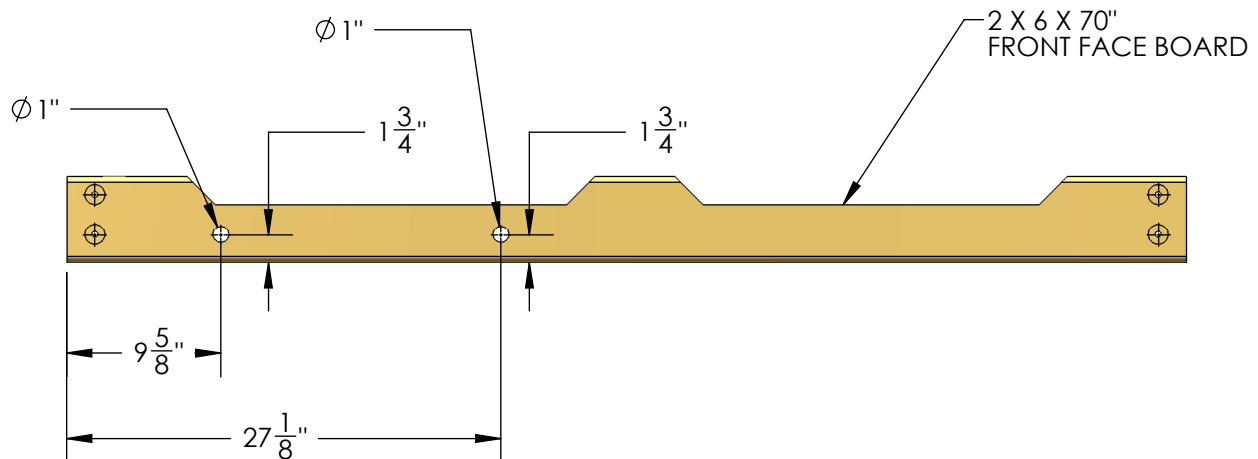
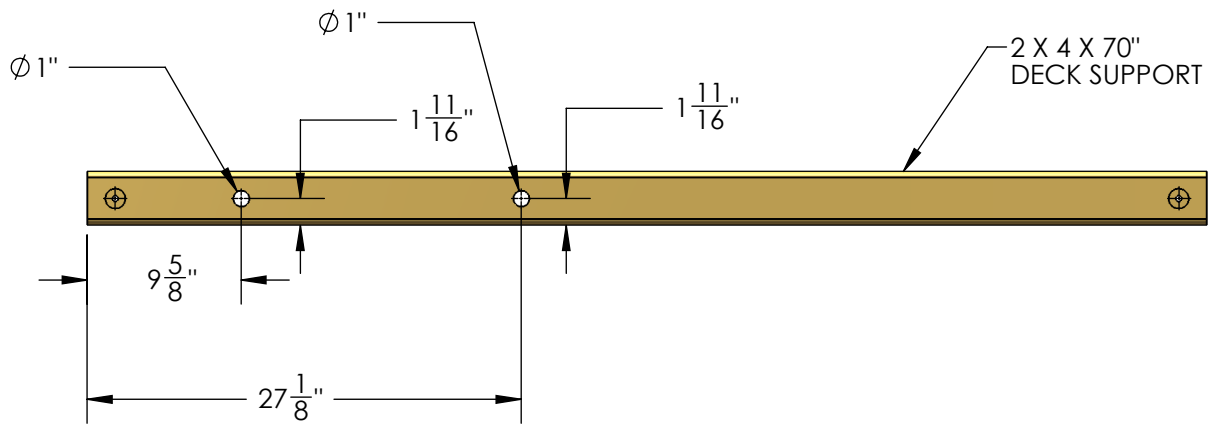

STEP 4: DECK SUPPORTS

YOU WILL NEED AN EXTRA PERSON FOR THIS STEP.

1: WITH HELP, STAND UP THE LEFT AND RIGHT SIDE ASSEMBLIES.

2: FASTEN THE 2 X 4 X 70" DECK SUPPORTS TO THE HOLES AT 54-3/4" WITH 5/16 X 4-1/2" HEX BOLTS AND 5/16" WASHERS FROM THE INSIDE OF THE PLAY SET.

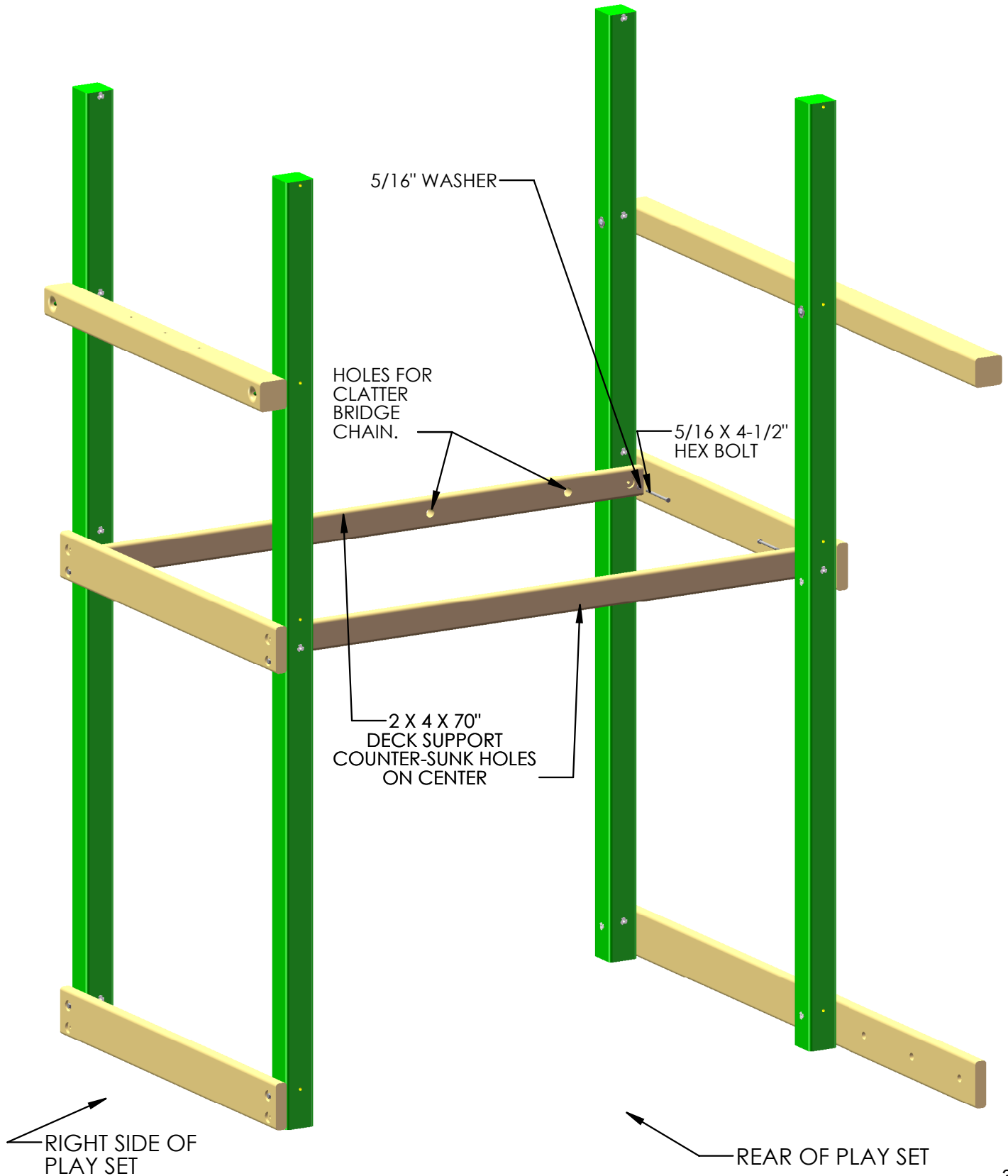

STEP 5: FRONT FRAME ASSEMBLY

1: PLACE THE 2 X 6 X 70" SANDBOX BOARD ON THE FRONT OF THE CORNER POSTS. THE OFFSET HOLES IN THE SANDBOX BOARD SHOULD FACE UP.

2: USE 5/16 X 4-1/2" HEX BOLTS AND 5/16" WASHERS TO ATTACH THE TOP HOLES OF THE SANDBOX BOARD TO THE T-NUTS INSTALLED ON THE CORNER POSTS. THE BOTTOM HOLES WILL BE USED LATER.

3: PLACE THE 2 X 6 X 70" FRONT FACE BOARD WITH NOTCHES ON THE FRONT OF THE CORNER POSTS. THE OFFSET HOLES IN THE FRONT FACE BOARD SHOULD FACE UP.

4: USE 5/16 X 4-1/2" HEX BOLTS AND 5/16" WASHERS TO ATTACH THE TOP HOLES OF THE FRONT FACE BOARD TO THE T-NUTS INSTALLED ON THE CORNER POSTS. THE BOTTOM HOLES WILL BE USED LATER.

5: PLACE THE 2 X 6 X 70" TOP PANEL BOARD ON THE FRONT OF THE CORNER POSTS. THE OFFSET HOLES IN THE TOP PANEL BOARD SHOULD FACE UP.

6: USE 5/16 X 4-1/2" HEX BOLTS AND 5/16" WASHERS TO ATTACH THE TOP HOLES OF THE TOP PANEL BOARD TO THE T-NUTS INSTALLED ON THE CORNER POSTS.

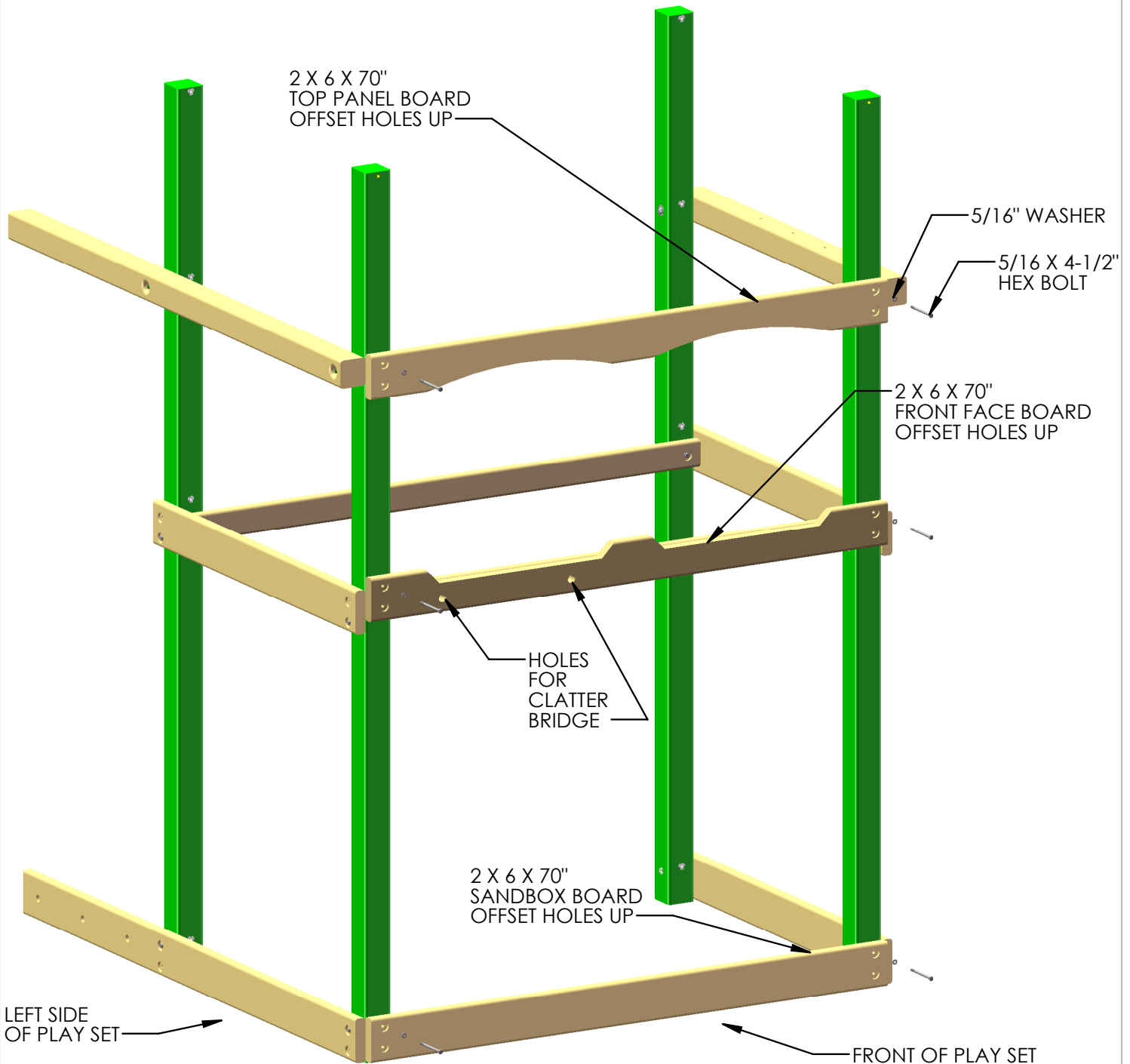

STEP 6: REAR FRAME ASSEMBLY

1: PLACE THE 2 X 6 X 70" SANDBOX BOARD ON THE REAR CORNER POSTS. THE OFFSET HOLES IN THE SANDBOX BOARD MUST FACE UP. USE 5/16" X 4-1/2" HEX BOLTS AND 5/16" WASHER TO ATTACH THE TOP HOLES OF THE SANDBOX BOARD TO THE T-NUTS INSTALLED ON THE CORNER POSTS.

2: PLACE THE 2 X 6 X 70" BOTTOM PANEL BOARD ON THE REAR CORNER POSTS. THE OFFSET HOLES IN THE BOTTOM PANEL BOARD MUST FACE UP. USE 5/16" X 4-1/2" HEX BOLTS AND 5/16" WASHERS TO ATTACH THE TOP HOLES OF THE BOTTOM PANEL BOARD TO THE T-NUTS INSTALLED ON THE CORNER POSTS.

3: PLACE THE 2 X 4 X 70" REAR TOP PANEL BOARD ON THE REAR CORNER POSTS. THE OFFSET HOLES IN THE REAR TOP PANEL MUST FACE UP. USE 5/16" X 4-1/2" HEX BOLTS AND 5/16" WASHER TO ATTACH THE TOP HOLES OF THE REAR TOP PANEL BOARD TO THE T-NUTS INSTALLED ON THE CORNER POSTS.

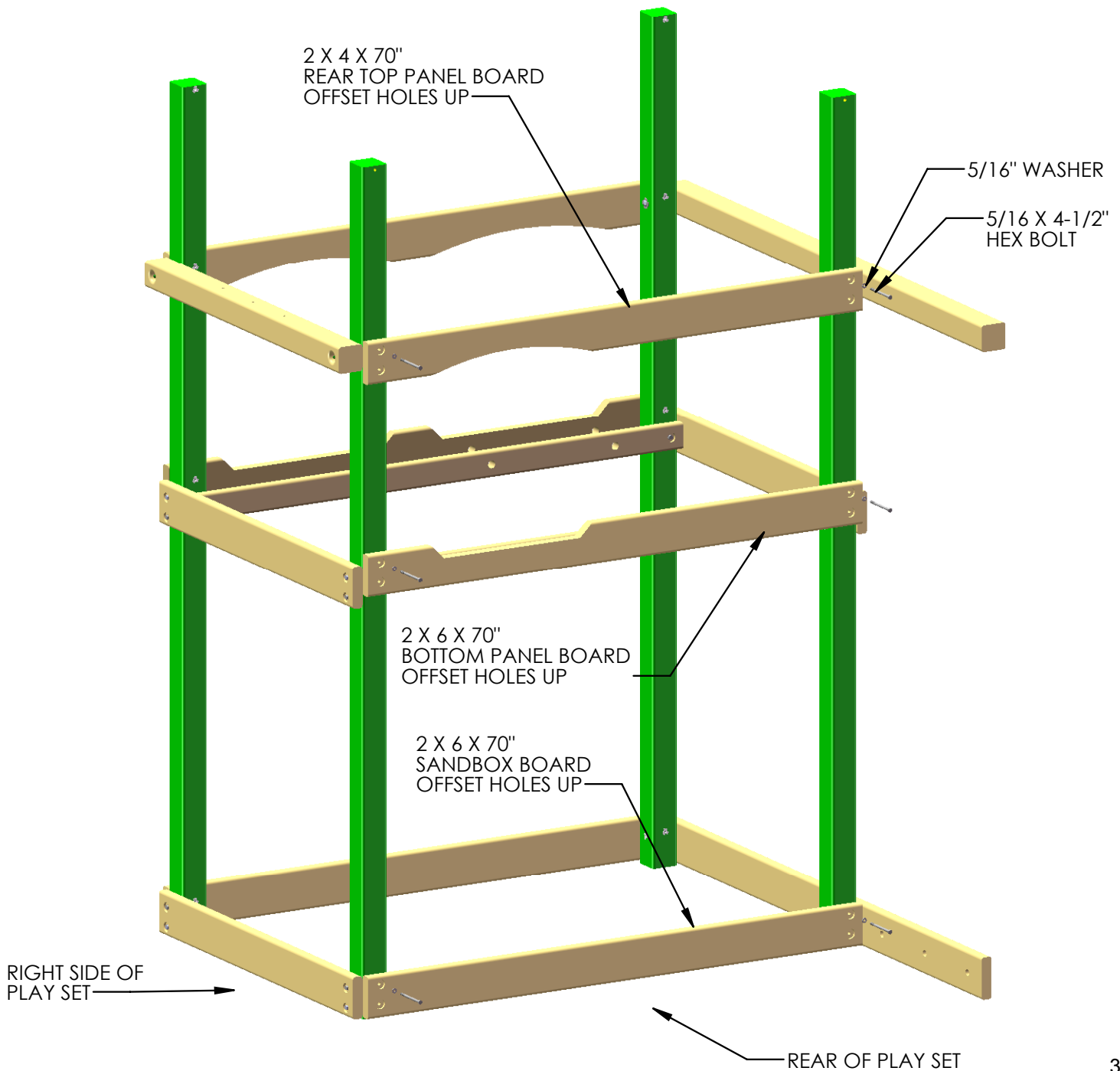

STEP 6A: LEVELING THE PLAY SET AND LAGS

1: INSTALL LAG SCREWS ONLY IN THE FOUR 2 X 6 BOARDS AT DECK HEIGHT AT THIS TIME. THIS IS TO MAKE THE STRUCTURE RIGID FOR THE LEVELING AND SQUARING PROCESS.

2: PLACE THE FRAME IN ITS FINAL POSITION AND FOLLOW THE PROCEDURES AT THE FRONT OF THE MANUAL TO LEVEL AND SQUARE THE STRUCTURE. HAVE AN ASSISTANT HELP YOU LIFT THE FRAME AS REQUIRED. **DO NOT** INSTALL REMAINING LAG SCREWS UNTIL AFTER THE FRAME HAS BEEN LEVELLED AND SQUARED.

2: ONCE THE FRAME IS LEVEL, SQUARE, AND SET INTO POSITION; GO BACK AND INSERT THE 5/16" X 3-1/2" LAG SCREWS AND 5/16" WASHERS IN ALL OF THE REMAINING HOLES OF THE 2 X 6 PARTS ON THE FRONT, SIDES AND REAR OF THE PLAY SET. NOTE: THERE WILL NOT BE ANY PREDRILLED HOLES IN THE CORNER POSTS FOR THE LAG SCREWS. LAG SCREWS ARE SELF-TAPPING.

IMPORTANT

INSTALL LAG SCREWS AND WASHERS ONLY IN THESE FOUR 2 X 6 BOARDS FIRST. THEN LEVEL/SQUARE THE FRAME. FINALLY, INSTALL LAG SCREWS IN THE REMAINING 2 X 6 BOARDS.

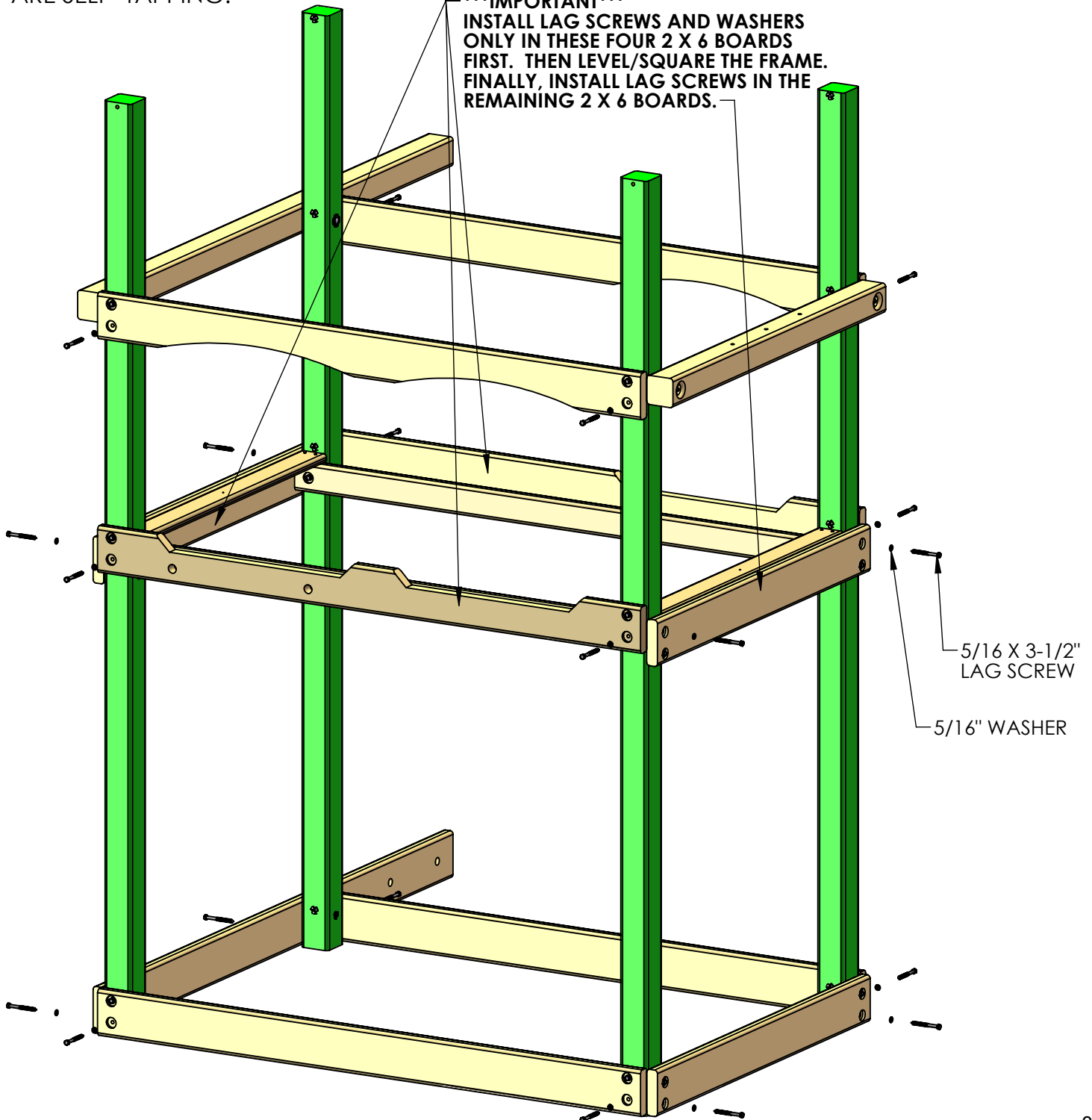

STEP 7: ANGLE SUPPORTS

1: FOUR 2 X 4 X 13" ANGLE SUPPORTS ARE MOUNTED UNDER THE DECK ON THE LEFT AND RIGHT SIDES OF THE PLAY SET TO THE 2 X 6 BOTTOM PANEL BOARDS. **THE TOP OF THE ANGLE SUPPORT SHOULD BE FLUSH OR LOWER THAN THE TOP OF THE DECK SUPPORT.**

2: AT THE TOP USE TWO 2-1/2" WOOD SCREWS THROUGH THE DECK SUPPORT INTO THE ANGLE SUPPORT. AT THE BOTTOM USE ONE 2" AND ONE 3" WOOD SCREW TO FASTEN THE ANGLE SUPPORT TO THE CORNER POST.

3: FOUR 2 X 4 X 18" ANGLE SUPPORTS ARE MOUNTED UNDER THE DECK ON THE FRONT AND REAR OF THE PLAY SET TO THE 2 X 4 DECK SUPPORTS. **THE TOP OF THE ANGLE SUPPORT SHOULD BE FLUSH OR LOWER THAN THE TOP OF THE DECK SUPPORT.**

4: AT THE TOP USE TWO 2-1/2" WOOD SCREWS THROUGH THE DECK SUPPORT INTO THE ANGLE SUPPORT. AT THE BOTTOM USE ONE 2" AND ONE 3" WOOD SCREW TO FASTEN THE ANGLE SUPPORT TO THE CORNER POST.

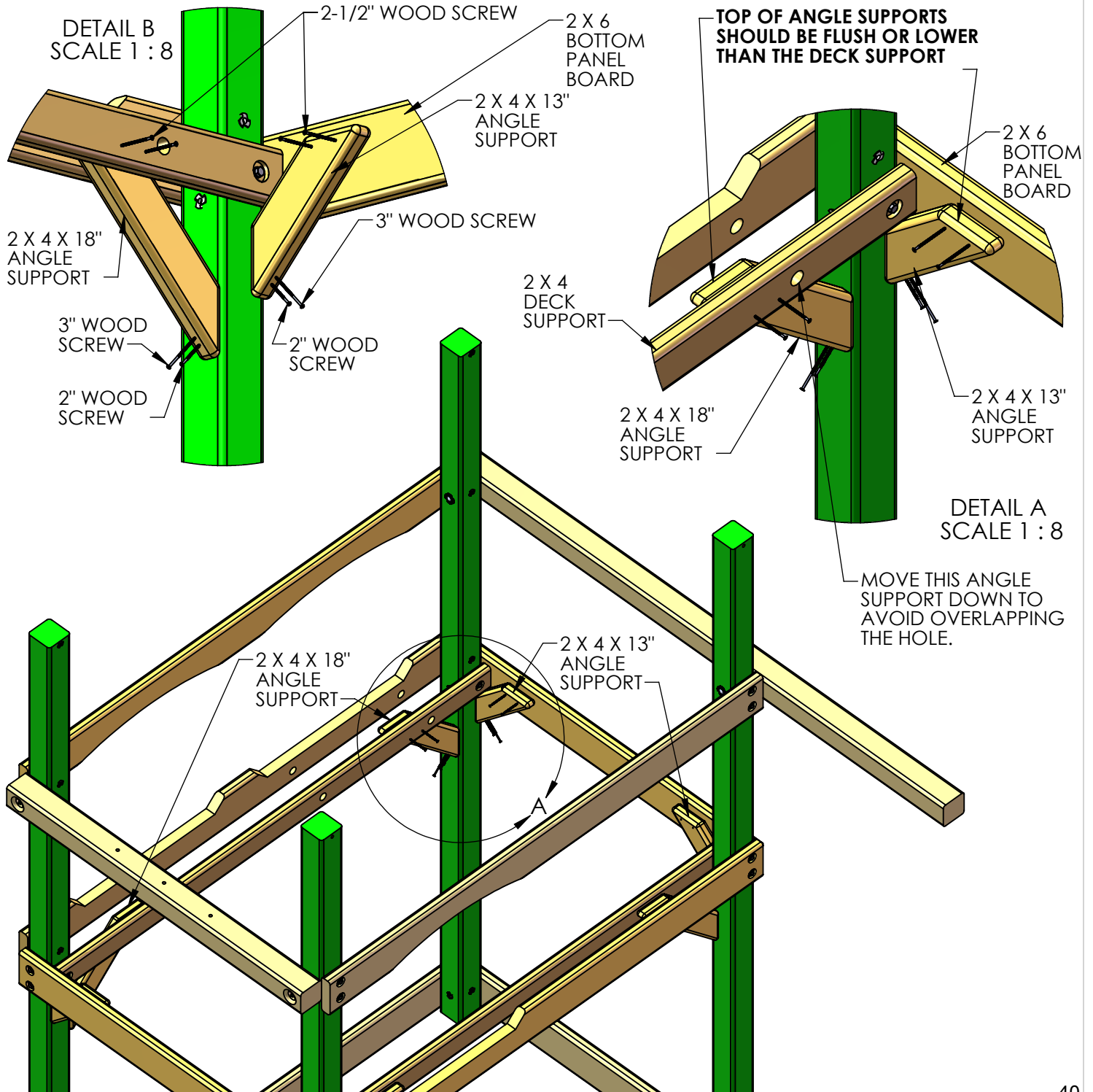

STEP 8: DECK SPACERS

THE FOLLOWING STEP IS RECOMMENDED TO PREVENT POSSIBLE SPLITS IN THE WOOD.

1: PRE-DRILL THE ENDS OF THE 5/4 X 4 X 40-1/2" DECK SPACERS TO PREVENT INSTALLATION DAMAGE. PRE-DRILL BOTH ENDS WITH A 1/8" DRILL BIT AT THE DIMENSIONS SHOWN BELOW. THE HOLE AT 20-1/4" ONLY NEEDS TO BE DRILLED ONCE. THIS HOLE IS TO ATTACH THE CENTER DECK SUPPORT TO THE DECK SPACER.

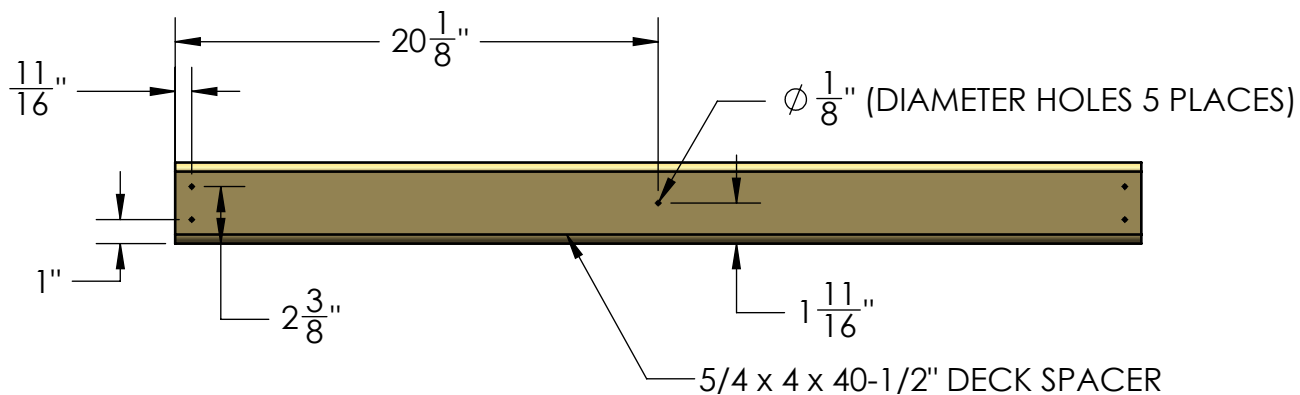

2: PLACE THE 5/4 X 4 X 40-1/2" DECK SPACER AT ONE END OF THE FORT. CENTER THE BOARD BETWEEN THE CORNER POSTS AND ATTACH IT WITH 2" WOOD SCREWS THROUGH THE PRE-DRILLED HOLES INTO THE DECK SUPPORT BELOW. NOTE THE TOP OF EACH SCREW HEAD SHOULD BE FLUSH TO THE TOP OF THE DECK SPACER.

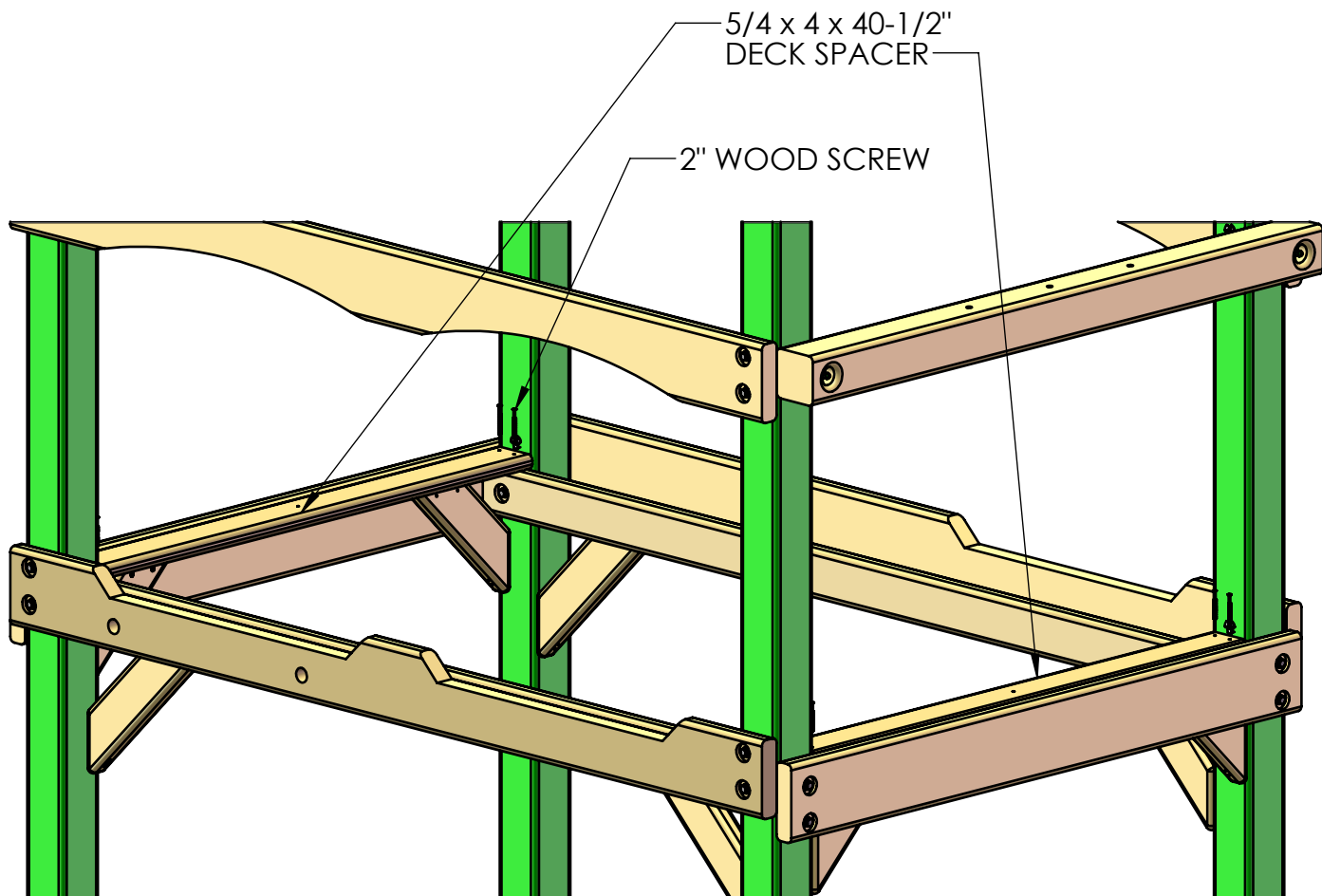

STEP 9: CENTER DECK SUPPORT

1: FIND THE 2 X 4 X 70" CENTER DECK SUPPORT WITHOUT HOLES.

2: USE THE HOLE IN THE CENTER OF THE DECK SPACER AS A GUIDE TO DRAW A LINE ON THE OUTSIDE OF THE BOTTOM PANEL BOARD ON EACH SIDE OF THE PLAY SET. (SEE DETAIL B) PLACE THE CENTER DECK SUPPORT UNDERNEATH THE DECK SPACERS THAT WERE PREVIOUSLY INSTALLED.

3: CENTER THE 2 X 4 X 70" CENTER DECK SUPPORT UNDER THE HOLE IN THE DECK SPACER. USE 2" WOOD SCREWS TO ATTACH THE DECK SPACERS TO THE CENTER DECK SUPPORT.

4: USING TWO 2-1/2" WOOD SCREWS, FASTEN THE END OF THE 2 X 4 X 70" CENTER DECK SUPPORT TO THE INSIDE OF THE BOTTOM PANEL BOARD. REPEAT THIS STEP ON THE OPPOSITE END OF THE FORT AS SHOWN IN DETAIL C.

DETAIL B

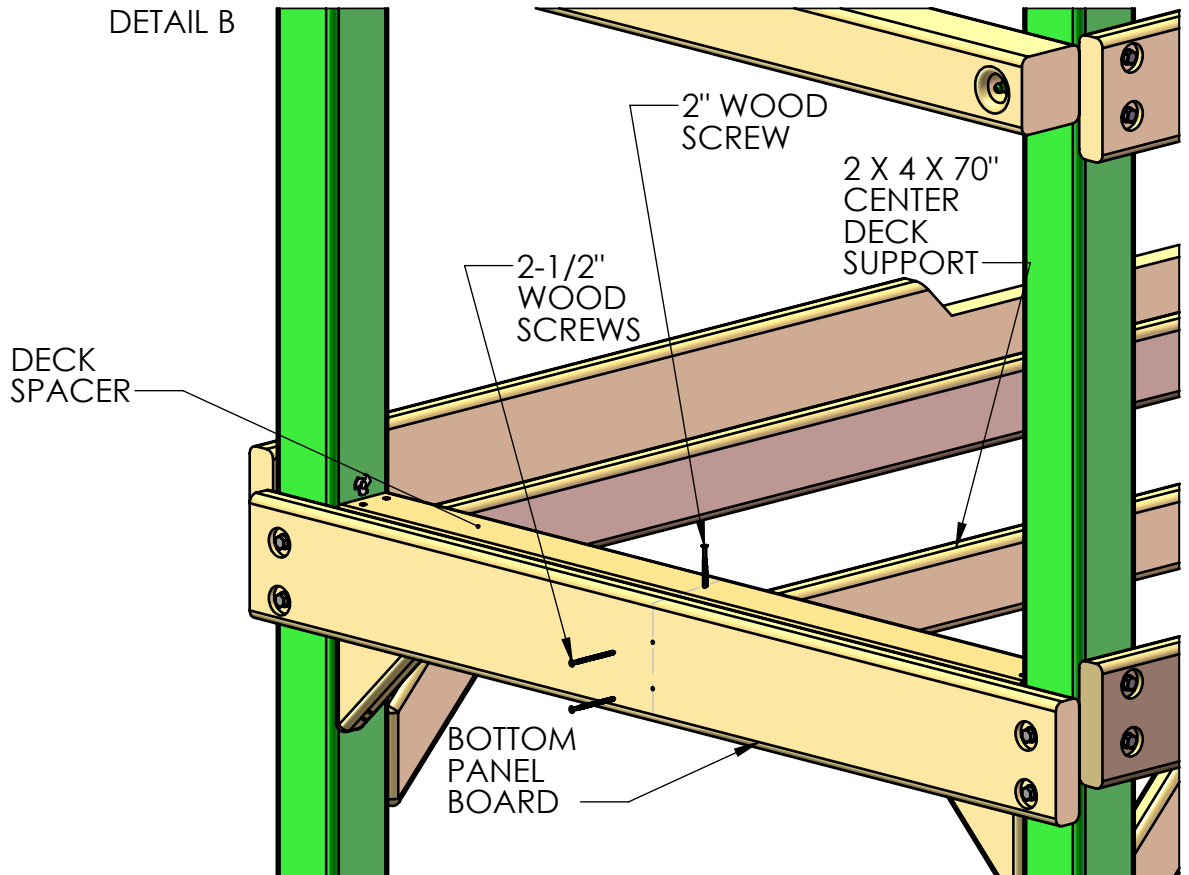

DETAIL C

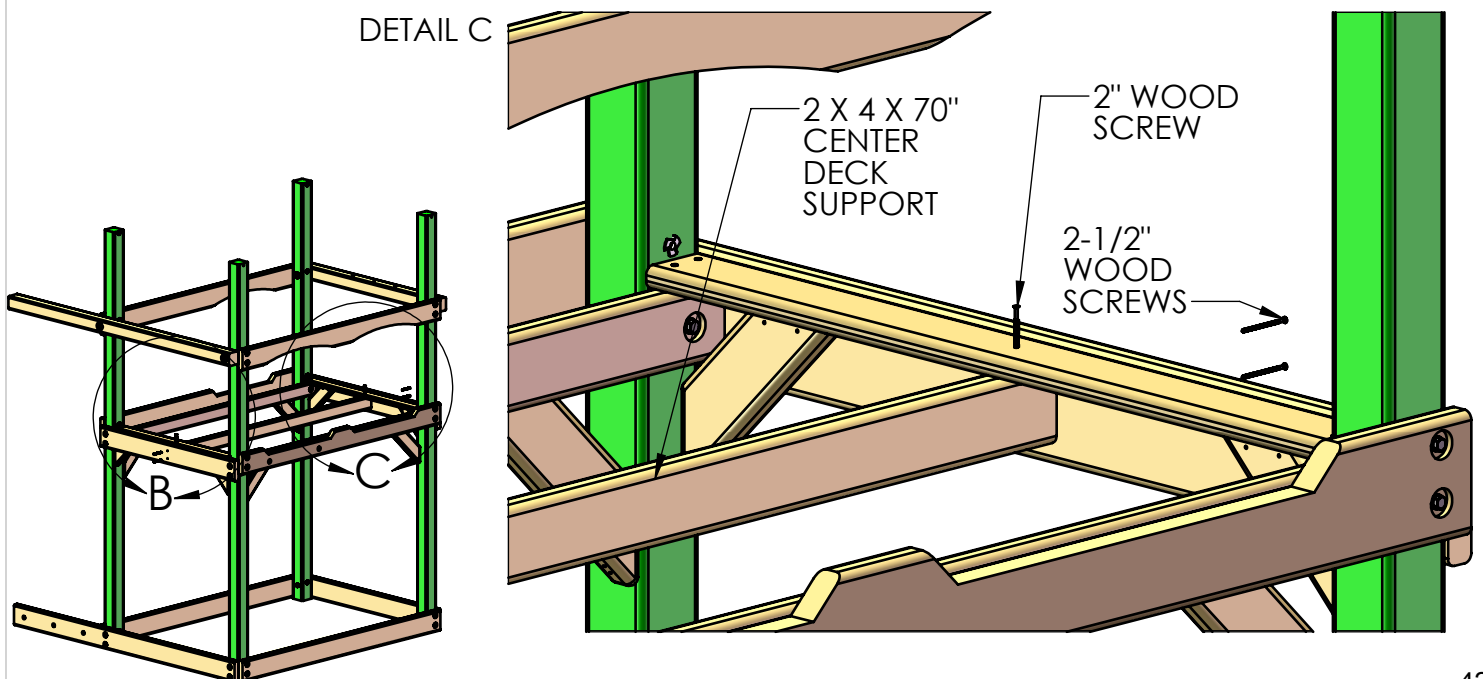

STEP 10: BOTTOM PANEL BOARDS

1: PLACE THE 2 X 4 X 47-1/2" BOTTOM PANEL BOARD ON TOP OF THE 2 X 6 PANEL BOARD WITH OFFSET HOLES DOWN AND FASTEN TO THE CORNER POSTS WITH 5/16" X 3-1/2" LAG SCREWS AND 5/16" WASHERS.

2: DO THE SAME PROCEDURE FOR THE OTHER SIDE USING A 2 X 4 X 47-1/2" BOTTOM PANEL BOARD, 5/16" X 3-1/2" LAG SCREWS AND 5/16" WASHERS.

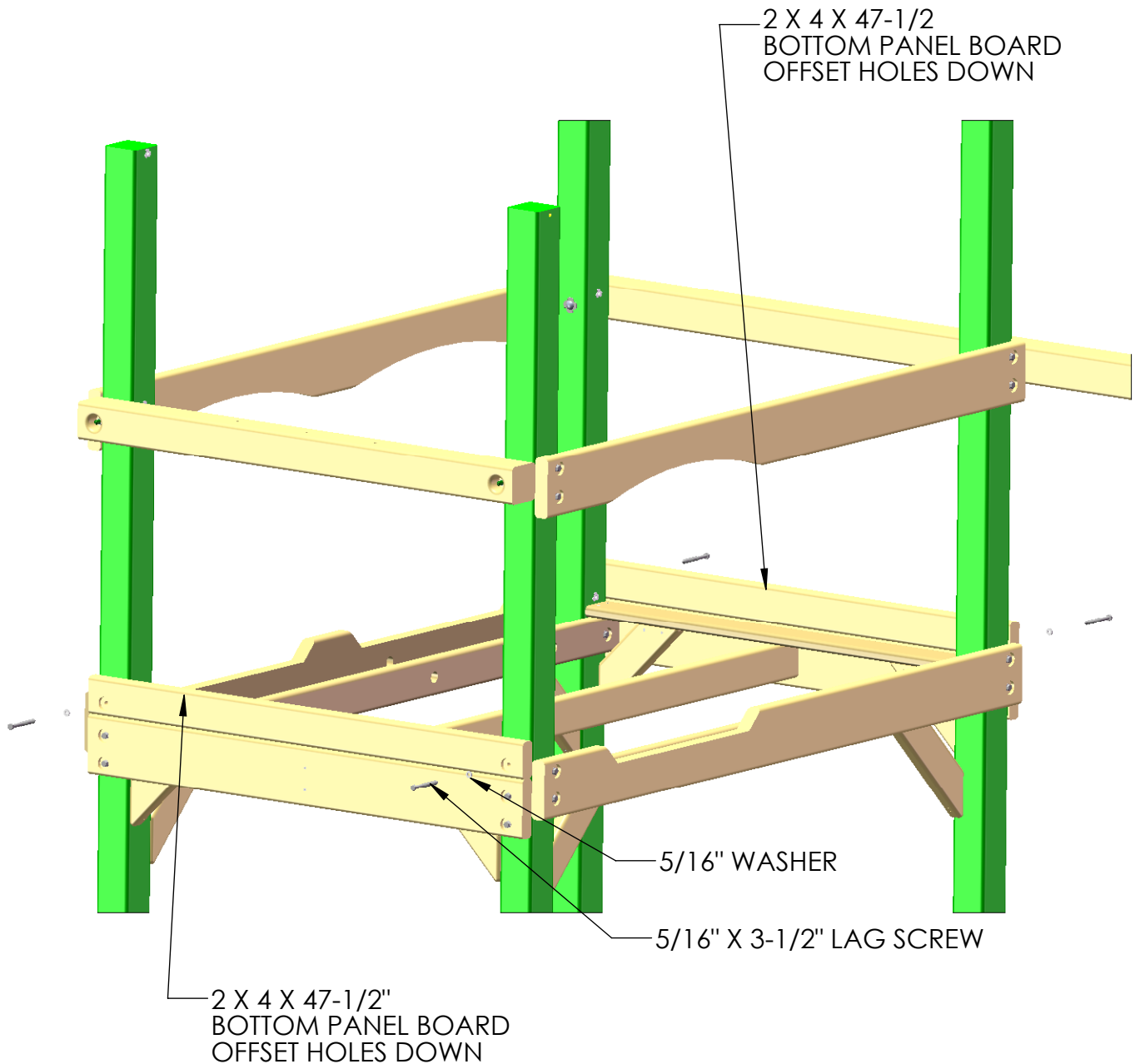

STEP 11: DECK BOARDS

THE FOLLOWING STEP IS RECOMMENDED TO PREVENT POSSIBLE SPLITS IN THE WOOD.

1: PRE-DRILL THE ENDS OF THE DECK BOARDS TO PREVENT INSTALLATION DAMAGE. PRE-DRILL BOTH ENDS WITH A 1/8" DRILL BIT AT THE DIMENSIONS SHOWN BELOW.

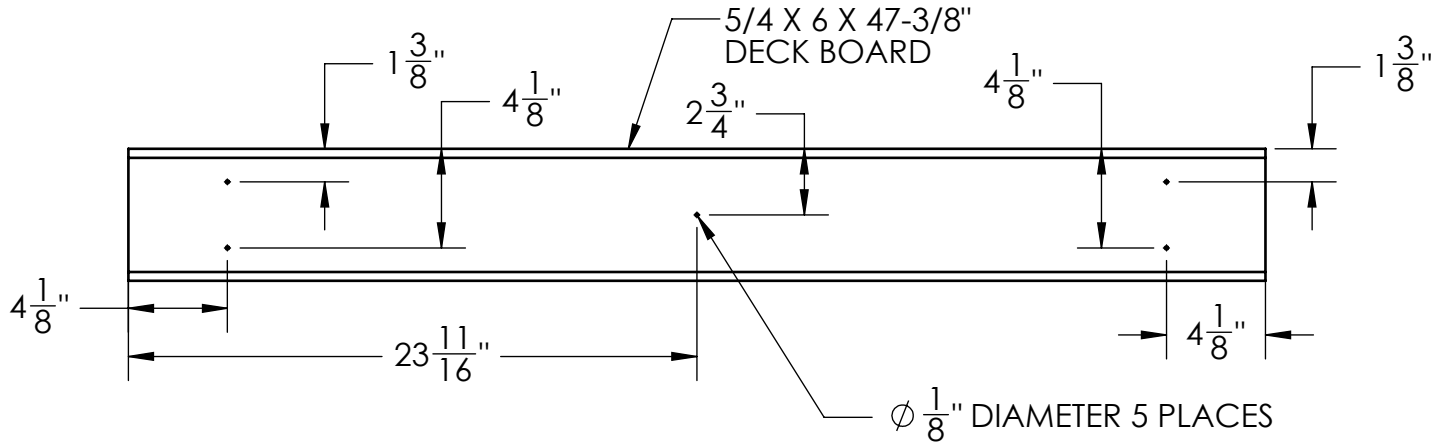

2: START WITH A 5/4 X 6 X 47-3/8" DECK BOARD AT ONE END OF THE FORT. CENTER THE BOARD BETWEEN THE FRONT FACE BOARD AND THE REAR BOTTOM PANEL BOARD AND ATTACH IT WITH 2" WOOD SCREWS THROUGH THE PREDRILLED HOLES AND INTO THE DECK SUPPORT SHOWN BELOW. LEAVE A UNIFORM (APPROXIMATELY 1/4") SPACE BETWEEN THE DECK BOARDS. NOTE THE TOP OF THE SCREW HEAD SHOULD BE FLUSH TO THE TOP OF THE DECK BOARDS.

LAY ALL DECK BOARDS ACROSS THE DECK SUPPORTS BEFORE SECURING THEM TO THE FORT. THIS WILL ENSURE THAT YOU HAVE EQUAL SPACING ACROSS THE DECK.

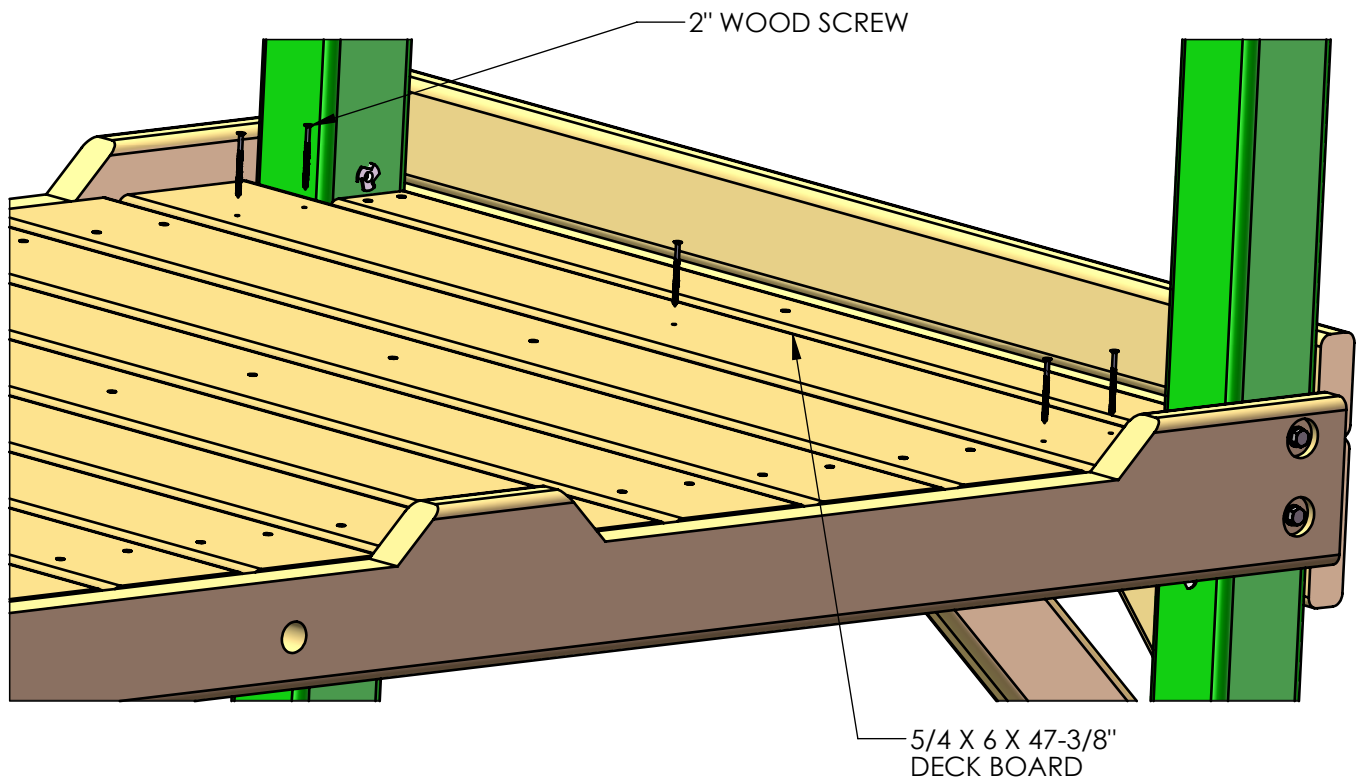

STEP 12: ROCK WALL

- 1: FIND TWO 2 X 4 X 66" ROCK WALL SIDES.
- 2: POSITION THE ROCK WALL SIDES SO THAT THE HOLES IN THE BOARDS ARE BOTH FACING THE SAME WAY.
- 3: INSERT T-NUTS INTO THE INSIDE OF THE ROCK WALL SIDES AND SET WITH A HAMMER.

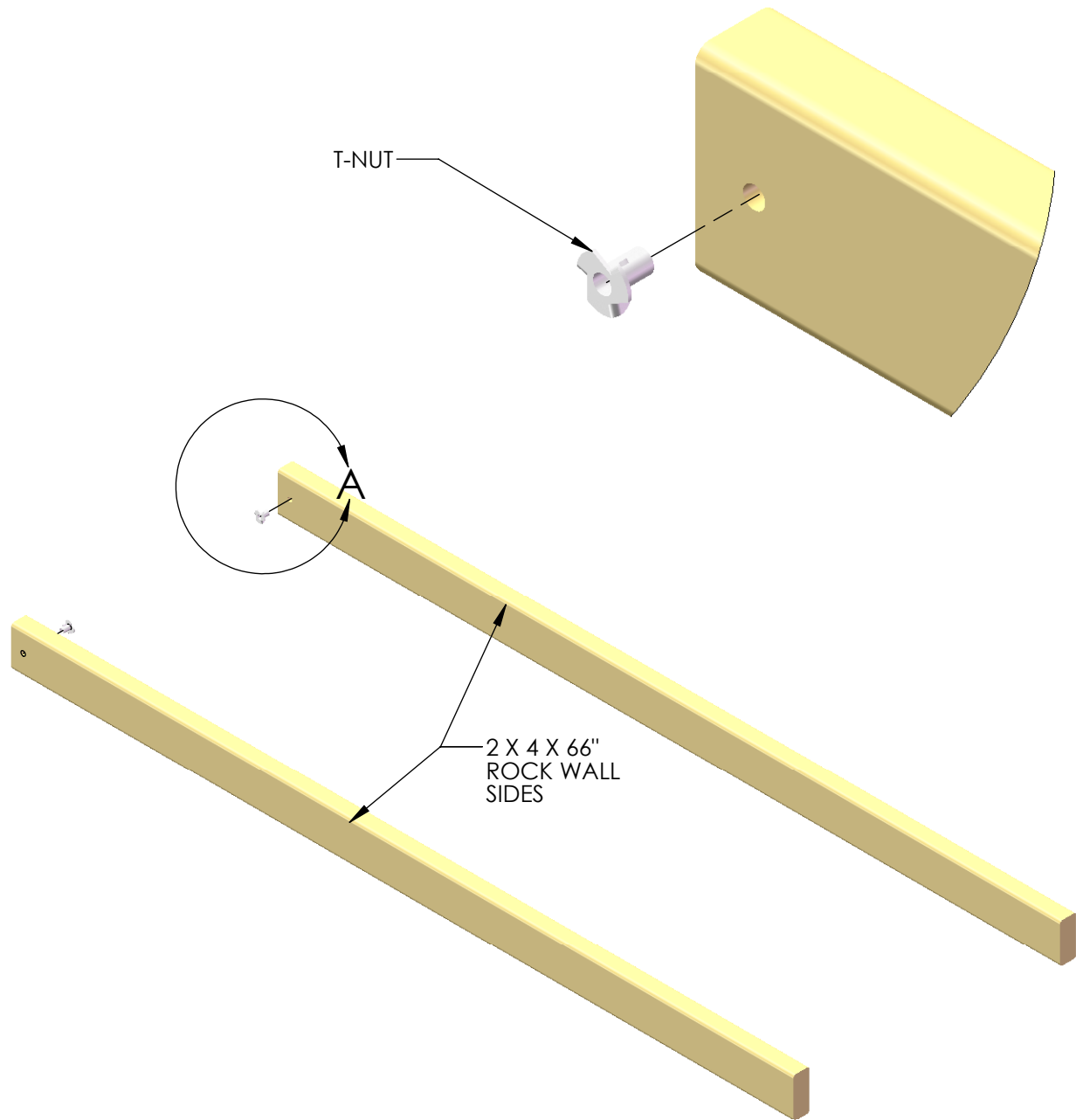

STEP 13: ROCK WALL

- 1: FIND ELEVEN 5/4 X 6 X 23-7/8" ROCK WALL BOARDS AND ONE 5/4 X 6 X 23-7/8" BOTTOM ROCK WALL BOARD (1 HOLE).
- 2: STARTING FROM THE TOP, PLACE ONE ROCK WALL BOARD ON TOP OF THE ROCK WALL SIDES, FLUSH TO THE TOP OF THE ROCK WALL SIDES, AND ATTACH WITH TWO 2" WOOD SCREWS ON EACH SIDE.
- 3: CONTINUE DOWN THE ROCK WALL WITH THE REMAINING ROCK WALL BOARDS, FASTENING EACH BOARD WITH TWO 2" WOOD SCREWS ON EACH END.
- 4: THE FINAL BOARD WILL BE THE BOTTOM ROCK WALL BOARD WITH ONE HOLE. ATTACH WITH TWO 2" WOOD SCREWS ON EACH SIDE.
- 5: IN SOME CASES, THERE WILL BE EXCESS LENGTH ON THE ROCK WALL SIDES. THIS IS DUE TO MILLING VARIATIONS, AND IS ALSO USED TO HELP LEVEL THE ROCK WALL SIDES ON UNEVEN GROUND.
- 6: ROCK WALL SIDES MAY NOT BE EVEN WITH THE BOTTOM ROCK WALL BOARD DUE TO MILLING VARIATIONS AND WOOD SHRINKAGE.

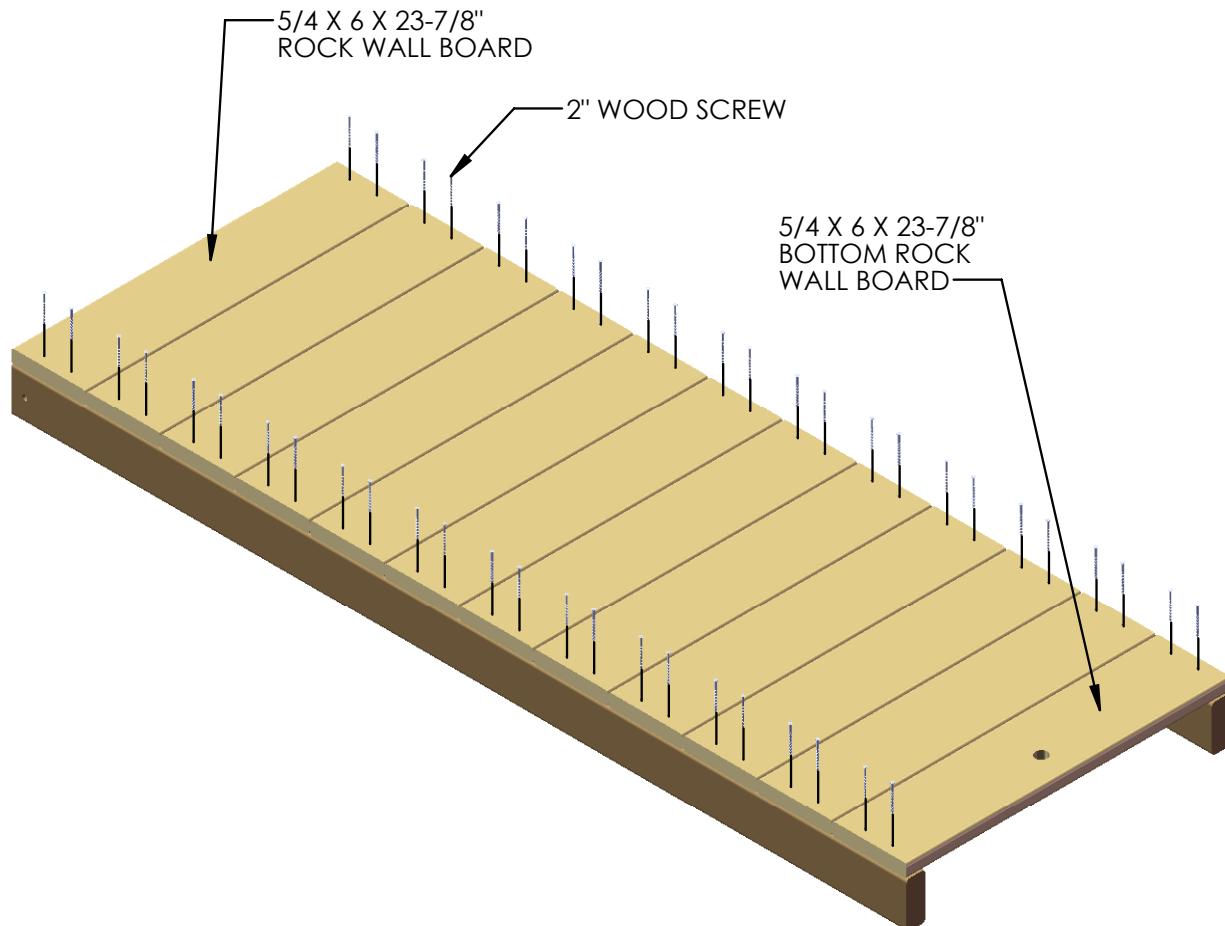

STEP 14: ROCK WALL

1: FASTEN THE 90° BRACKET TO THE ROCK WALL SIDES WITH 5/16 X 1-1/2" HEX BOLTS AND 5/16" WASHERS.

2: DO NOT TIGHTEN THE HEX BOLTS INTO THE T-NUTS AT THIS TIME.

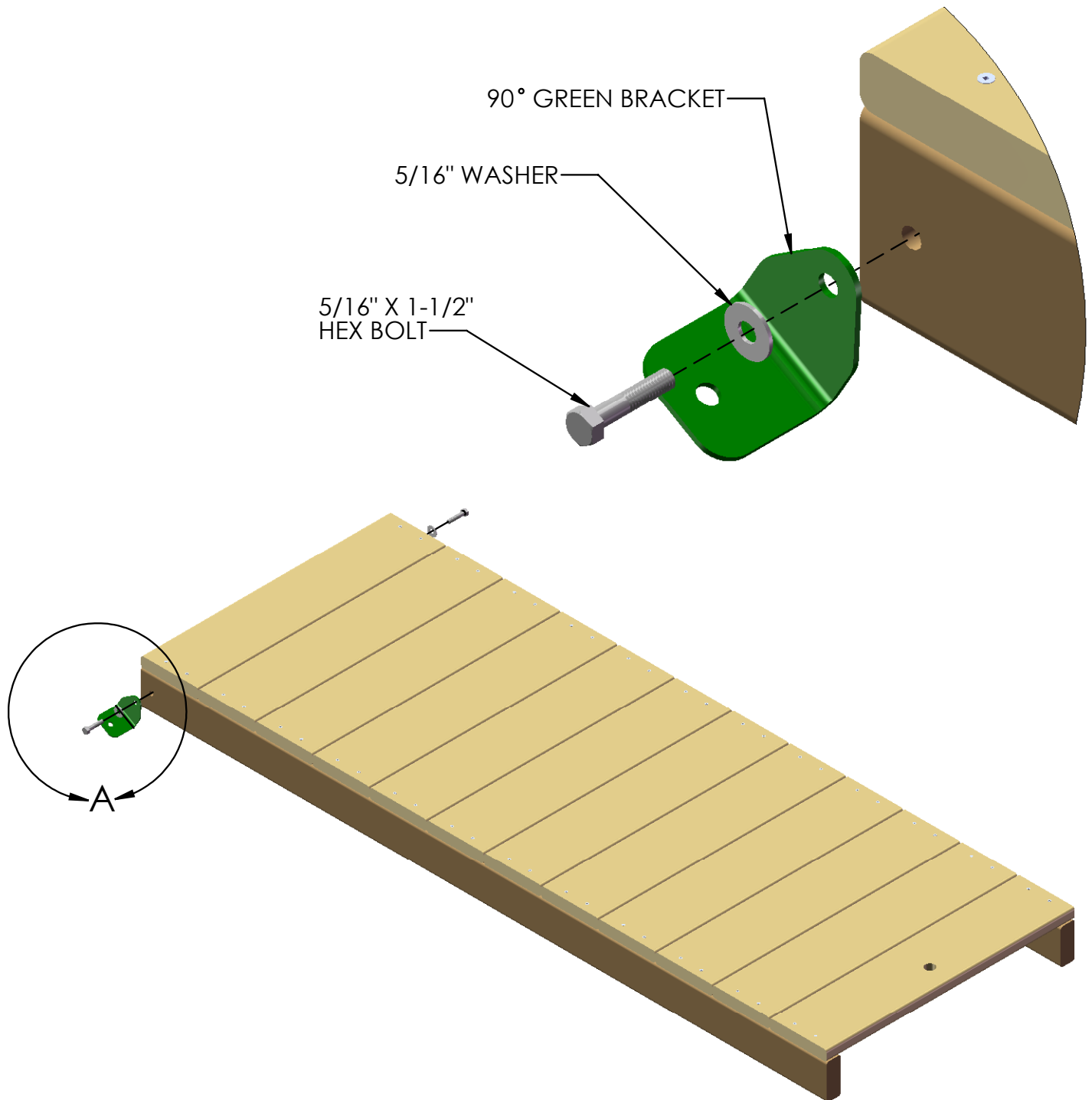

STEP 15: ROCK WALL

1: FIND TEN ROCKS AND THIRTY 1-1/4" PAN HEAD SCREWS AND THIRTY 1/4" WASHERS.

2: MOUNT THE ROCKS IN A STAGGERED MANNER ON THE ROCK WALL BOARDS. THREE PAN HEAD SCREWS WITH THREE WASHERS WILL SECURE EACH ROCK TO THE WALL.

NOTE: THE IMAGE SHOWN BELOW IS A GENERIC ARRANGEMENT OF ROCKS ON THE ROCK WALL. YOUR ACTUAL CONFIGURATION MAY BE DIFFERENT THAN WHAT YOU SEE BELOW. ROCKS CAN BE ARRANGED IN ANY PATTERN AS LONG AS THEY WILL ALLOW PROPER ACCESS TO THE FORT. BE CREATIVE.

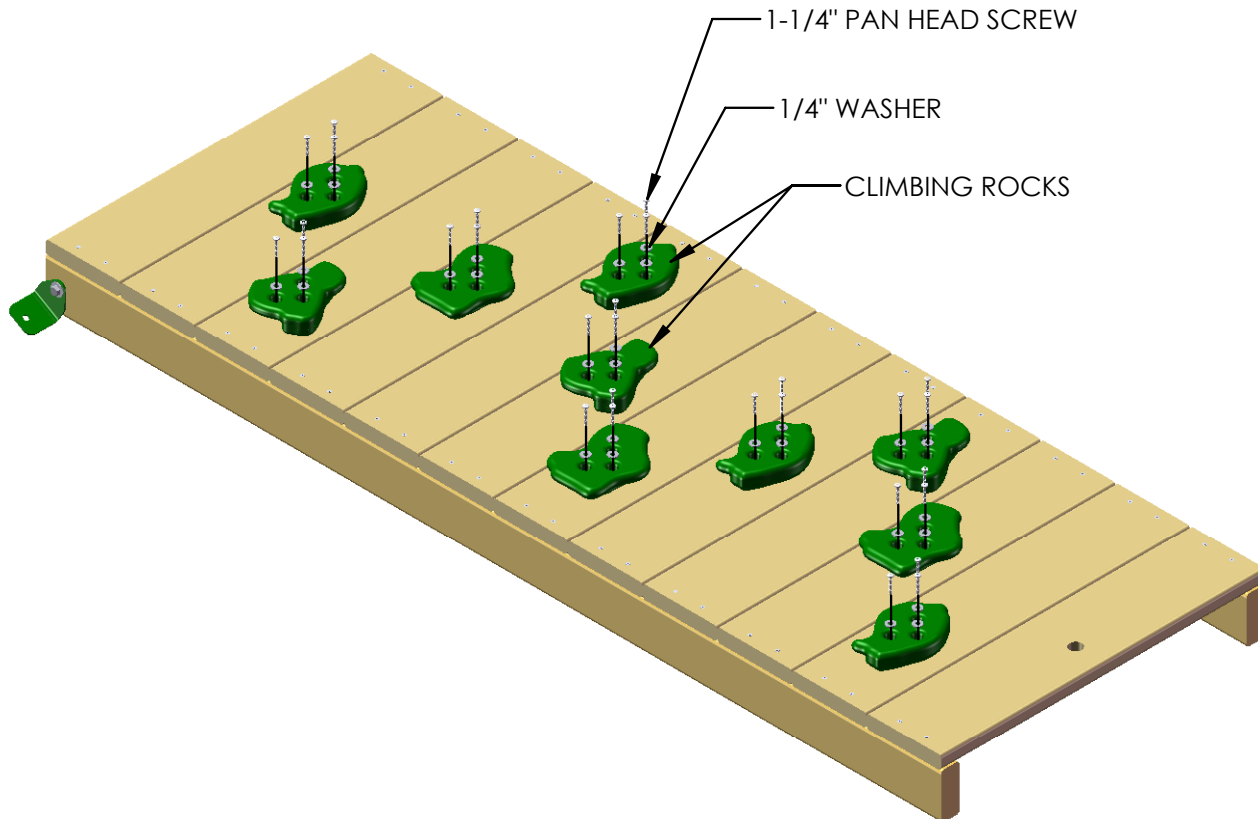

3: PLACE THE 5/4 X 2-5/8 X 23-7/8" ROCK WALL TOP CAP ON TOP OF THE ROCK WALL SIDES. FASTEN THE ROCK WALL TOP CAP TO THE ROCK WALL SIDES WITH 2" WOOD SCREWS.

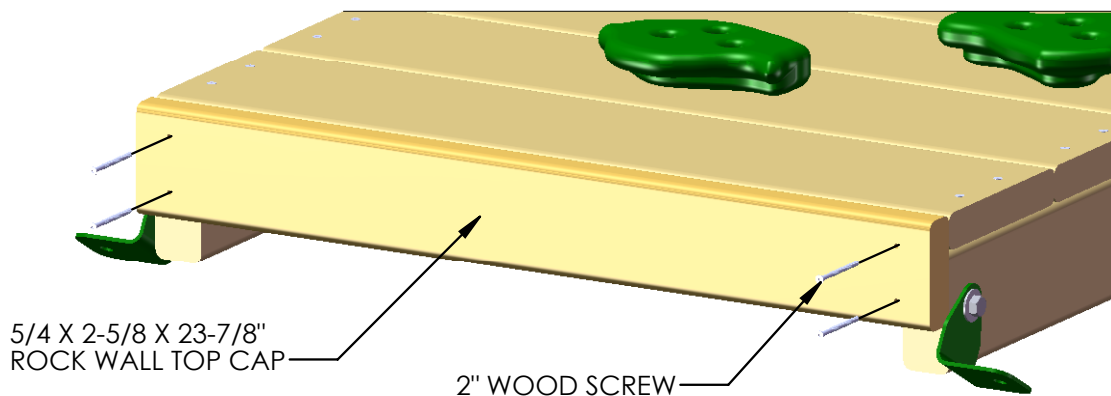

STEP 16: ATTACHING THE ROCK WALL

1: PLACE THE ROCK WALL INTO POSITION ON THE FRONT SIDE - RIGHT OF THE PLAY SET AS SHOWN BELOW. THE BOTTOM OF THE 90° BRACKETS SHOULD BE APPROXIMATELY 3/4" FROM THE BOTTOM OF THE FRONT FACE BOARD. USING THE 90° BRACKETS AS A TEMPLATE; DRILL A 3/8" HOLE THROUGH THE FRONT FACE BOARD.

2: FROM THE UNDERSIDE OF THE DECK INSERT A T-NUT INTO THE BACKSIDE OF THE 3/8" HOLES ON THE FRONT FACE BOARD.

3: ATTACH THE ROCK WALL WITH 5/16 X 1-1/2" BOLTS AND 5/16" WASHERS.

4: WHEN THE 90° BRACKETS ARE SECURE, AND THE ROCK WALL IS IN ITS FINAL POSITION; TIGHTEN THE 5/16 X 1-1/2" BOLTS ON THE ROCK WALL SIDES.

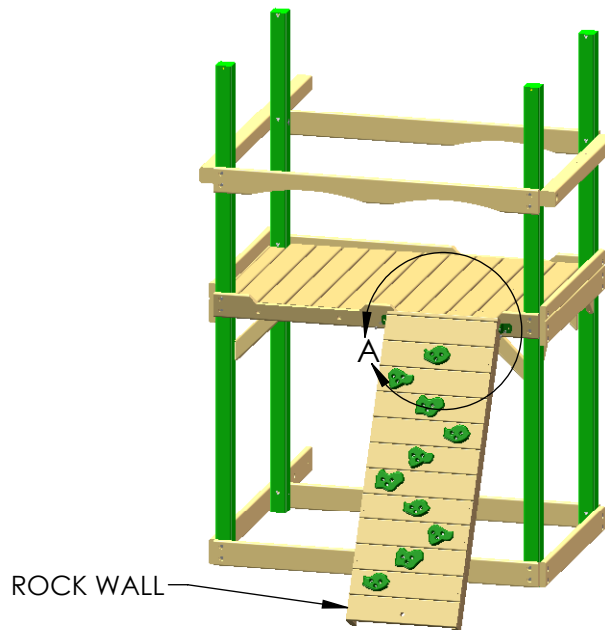

NOTE: T-NUT GOES IN BACK SIDE OF HOLE DRILLED ON EACH SIDE.



STEP 17: LADDER

- 1: FIND TWO 2 X 4 X 66" LADDER SIDES.
- 2: POSITION THE LADDER SIDES SO THAT THE SLOTS IN THE BOARDS ARE FACING EACH OTHER AND ARE PARALLEL.
- 3: INSERT T-NUTS INTO THE OUTSIDE OF THE LADDER SIDES AND SET WITH A HAMMER.

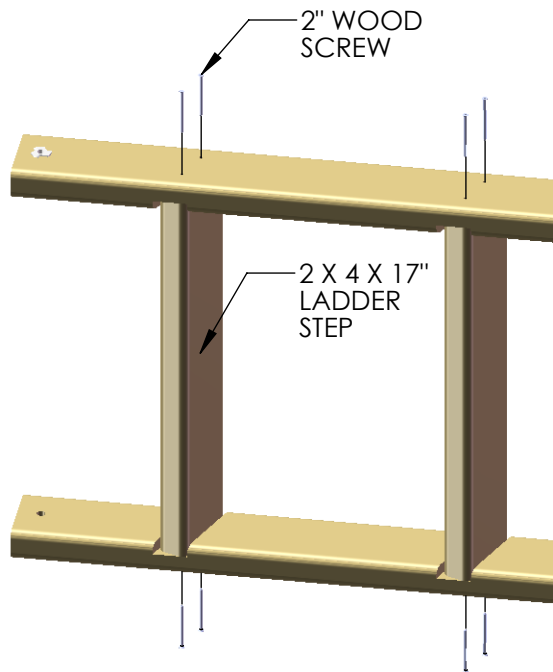
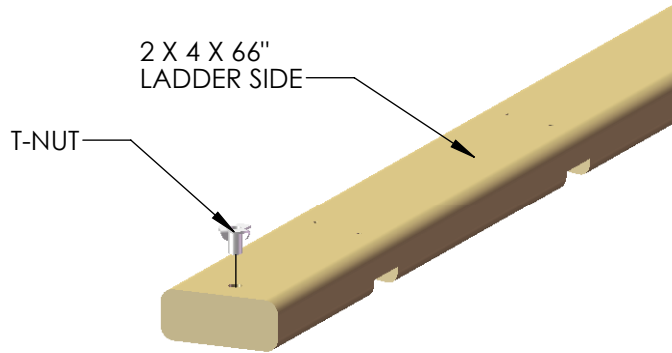

- 4: FIND FIVE 2 X 4 X 17" LADDER STEPS.

5: PLACE THE STEPS INTO THE SLOTS ON THE LADDER SIDES, AND FASTEN WITH 2" WOOD SCREWS.

6: CAREFULLY TURN THE LADDER OVER AND PUT THE SCREWS INTO THE OTHER SIDE.

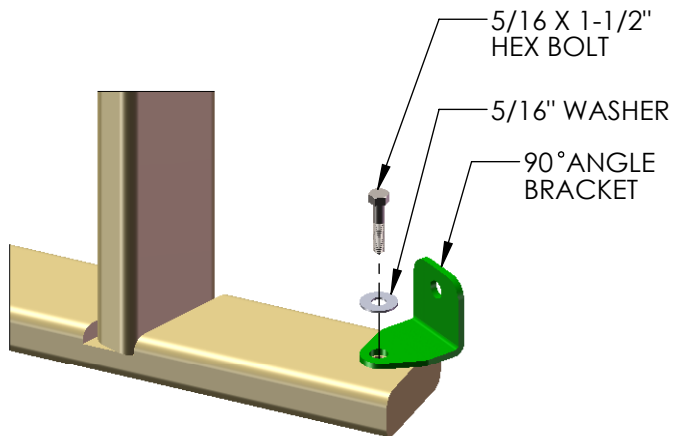

7: INSTALL THE 90° ANGLE BRACKETS TO THE INSIDE OF THE LADDER RAILS WITH 5/16 X 1-1/2" BOLTS, 5/16 WASHERS, INTO THE 5/16" T-NUTS.

8: INSTALL THE 5/4 X 3 X 18-3/4" LADDER BACK ABOVE THE TOP STEP OF THE LADDER WITH TWO 2" WOOD SCREWS PER SIDE.

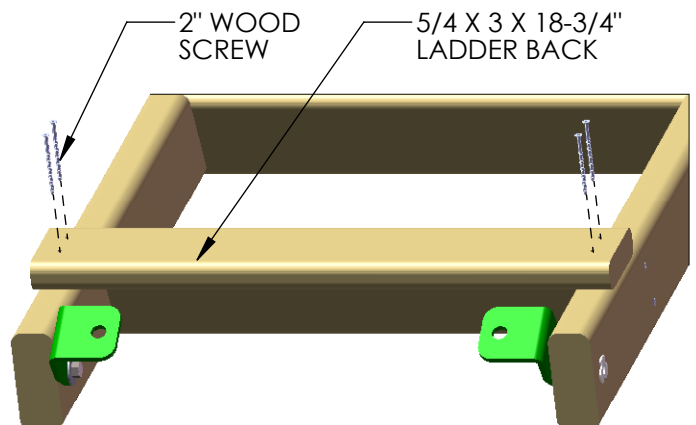

STEP 18: LADDER TO PLAY SET

1: THE LADDER WILL ATTACH TO THE REAR OF THE PLAY SET. PLACE THE LADDER AGAINST THE BOTTOM PANEL BOARD CENTERED IN THE NOTCHED OUT AREA.

2: THE BOTTOM OF THE 90° BRACKETS SHOULD BE APPROXIMATELY 3/4" FROM THE BOTTOM OF THE BOTTOM PANEL BOARD. USING THE 90° BRACKETS AS A TEMPLATE DRILL A 3/8" HOLE THROUGH THE BOTTOM PANEL BOARD.

3: FROM THE UNDERSIDE OF THE DECK INSERT A T-NUT INTO THE BACKSIDE OF THE 3/8" HOLES ON THE BOTTOM PANEL BOARD.

4: ATTACH THE LADDER WITH 5/16" X 1-1/2" BOLTS AND 5/16" WASHERS.

5: WHEN THE 90° BRACKETS ARE SECURE, AND THE LADDER IS IN ITS FINAL POSITION TIGHTEN THE 5/16" X 1-1/2" BOLTS ON THE INSIDE OF THE LADDER SIDES.

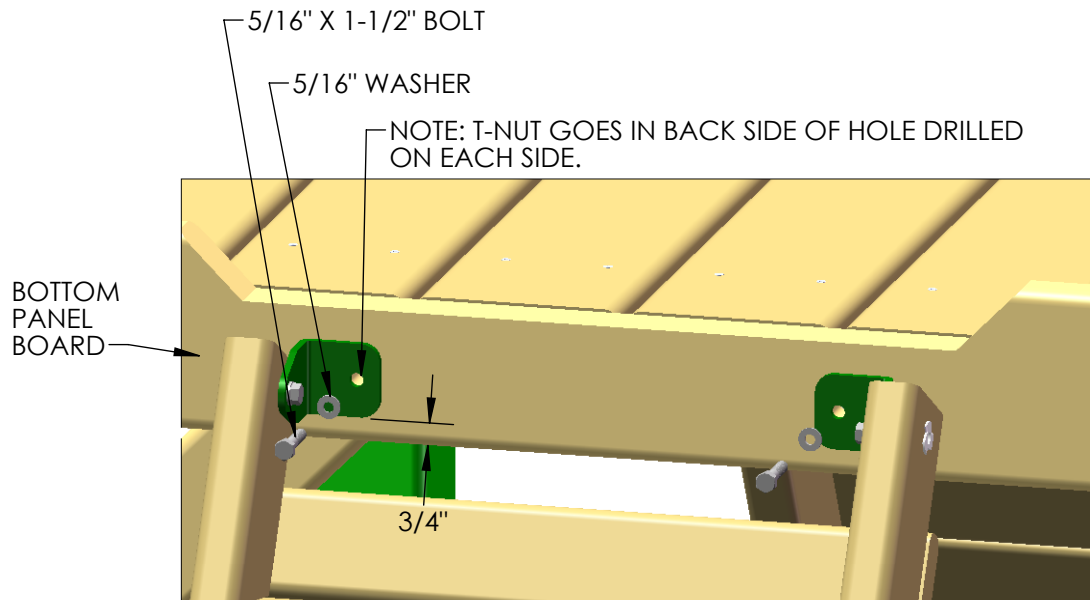
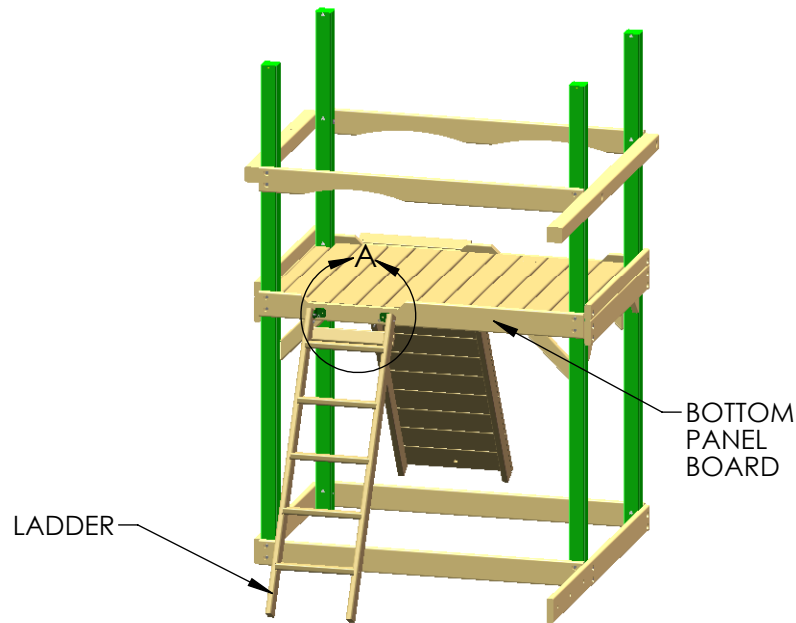

STEP 19: FRONT PANEL SLATS

- 1: FIND ONE 1 X 4 X 25" FRONT PANEL SLATS AND ONE 4 X 4 X 26" CENTER POST.
- 2: PREDRILL THE SLAT 1" FROM EACH END WITH TWO HOLES EQUALLY SPACED WITH A 1/8" DRILL BIT
- 3: INSTALL THE PANEL SLAT AS SHOWN ON THE FIGURE BELOW AND ATTACH WITH 2" WOOD SCREWS.
- 4: PLACE THE 4 X 4 X 26" CENTER POST 29-3/4" AWAY FROM THE LEFT FRONT CORNER POST AS SHOWN.
- 5: ATTACH THE CENTER POST TO THE TOP PANEL BOARD WITH TWO 3" WOOD SCREWS. GO UNDERNEATH THE DECK TO ATTACH THE CENTER POST TO THE DECK BOARD WITH THREE 3" WOOD SCREWS.

2" WOOD SCREWS

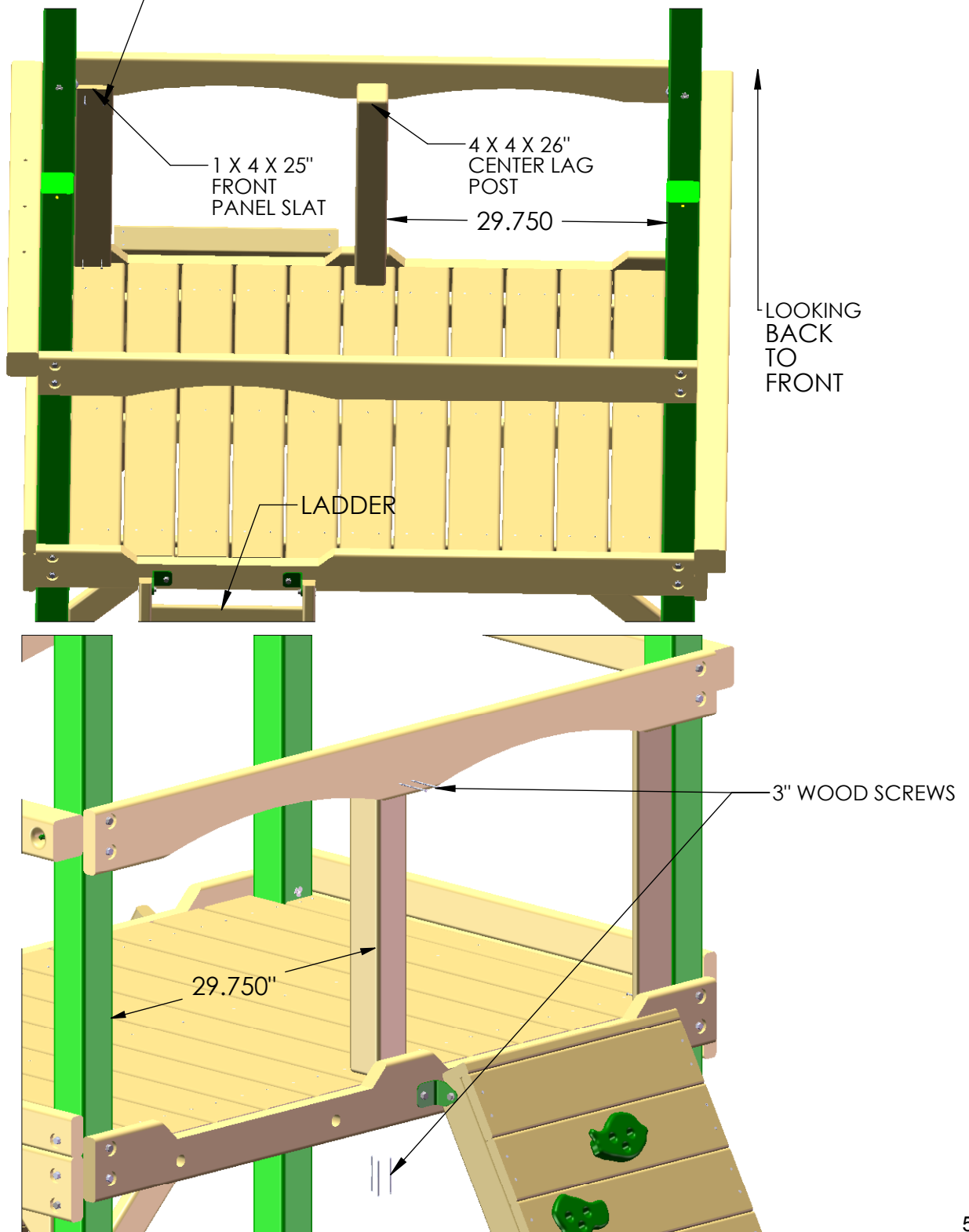

STEP 20: SIDE PANEL SLATS

- 1: FIND ELEVEN 1 X 6 X 27-3/4" PANEL SLATS.
- 2: PRE-DRILL THE PANEL SLATS 1" FROM EACH END WITH TWO EQUALLY SPACED HOLES WITH A 1/8" DRILL BIT.
3. INSTALL THE PANEL SLATS AS SHOWN LEAVING 1/4" GAP BETWEEN EACH PANEL SLAT OR A 1/4" GAP BETWEEN THE CORNER POST AND PANEL SLAT.
4. ATTACH THE PANEL SLATS TO THE PLAY SET WITH 1-1/2" WOOD SCREWS IN THE PREDRILLED HOLES.

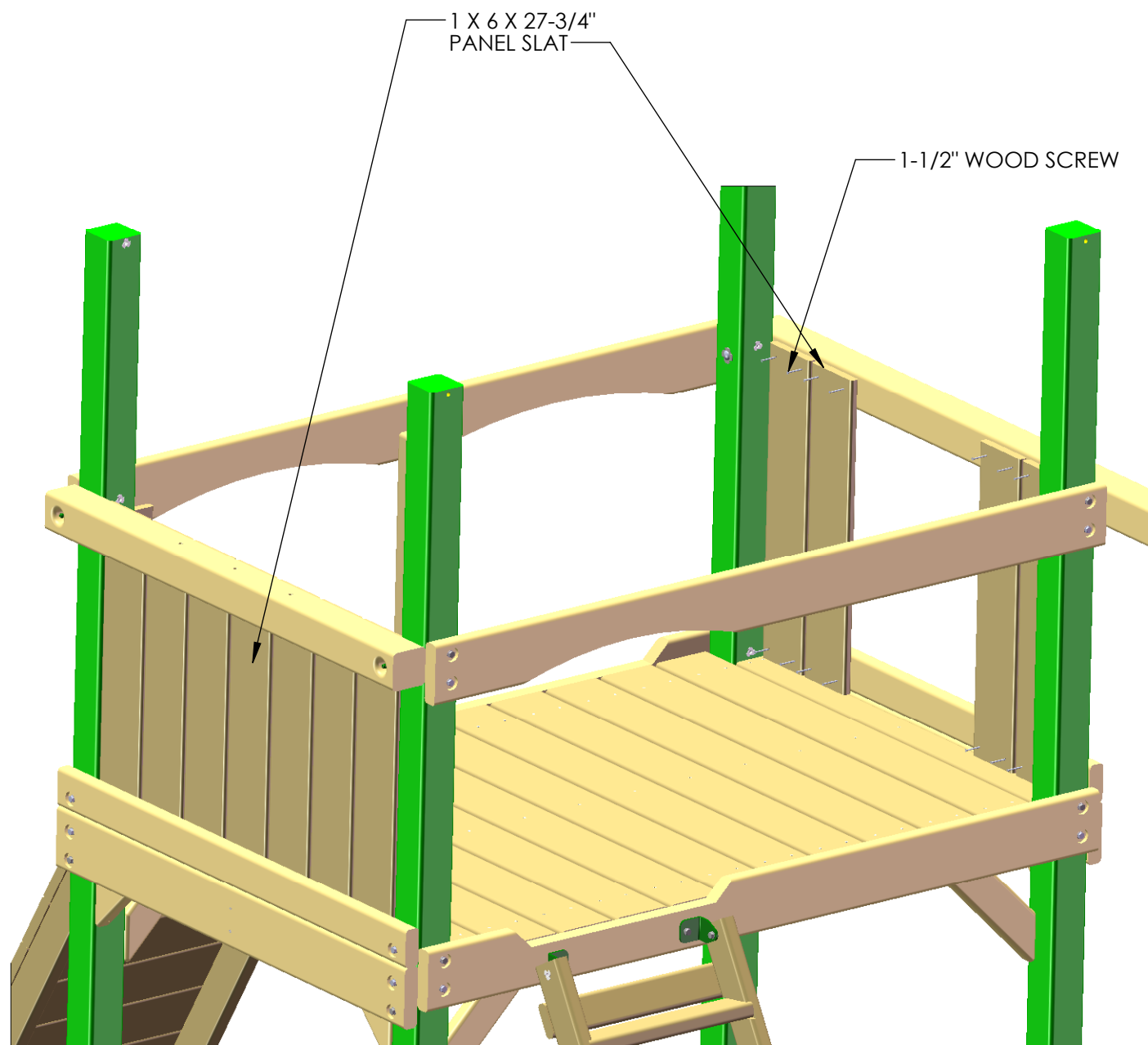

STEP 21: TIC TAC TOE SUPPORT

- 1: FIND TWO 1 X 6 X 16" TIC TAC TOE SUPPORT SLATS.
- 2: PRE-DRILL THE SLATS 2" FROM EACH END, AND 4" OVER FROM THE FIRST HOLE AS SHOWN ON THE DIAGRAM USING A 1/8" DRILL BIT.
- 3: INSTALL THE SLATS IN THE GAP LEFT FROM THE PREVIOUS INSTALLATION LEAVING A 3/4" GAP ON THE END.
- 4: ATTACH THE PANEL SLATS TO THE FORT WITH 1-1/2" WOOD SCREWS IN THE PRE-DRILLED HOLES LEAVING A 16-13/16" OPENING BETWEEN THE TIC TAC TOE SUPPORT SLATS.

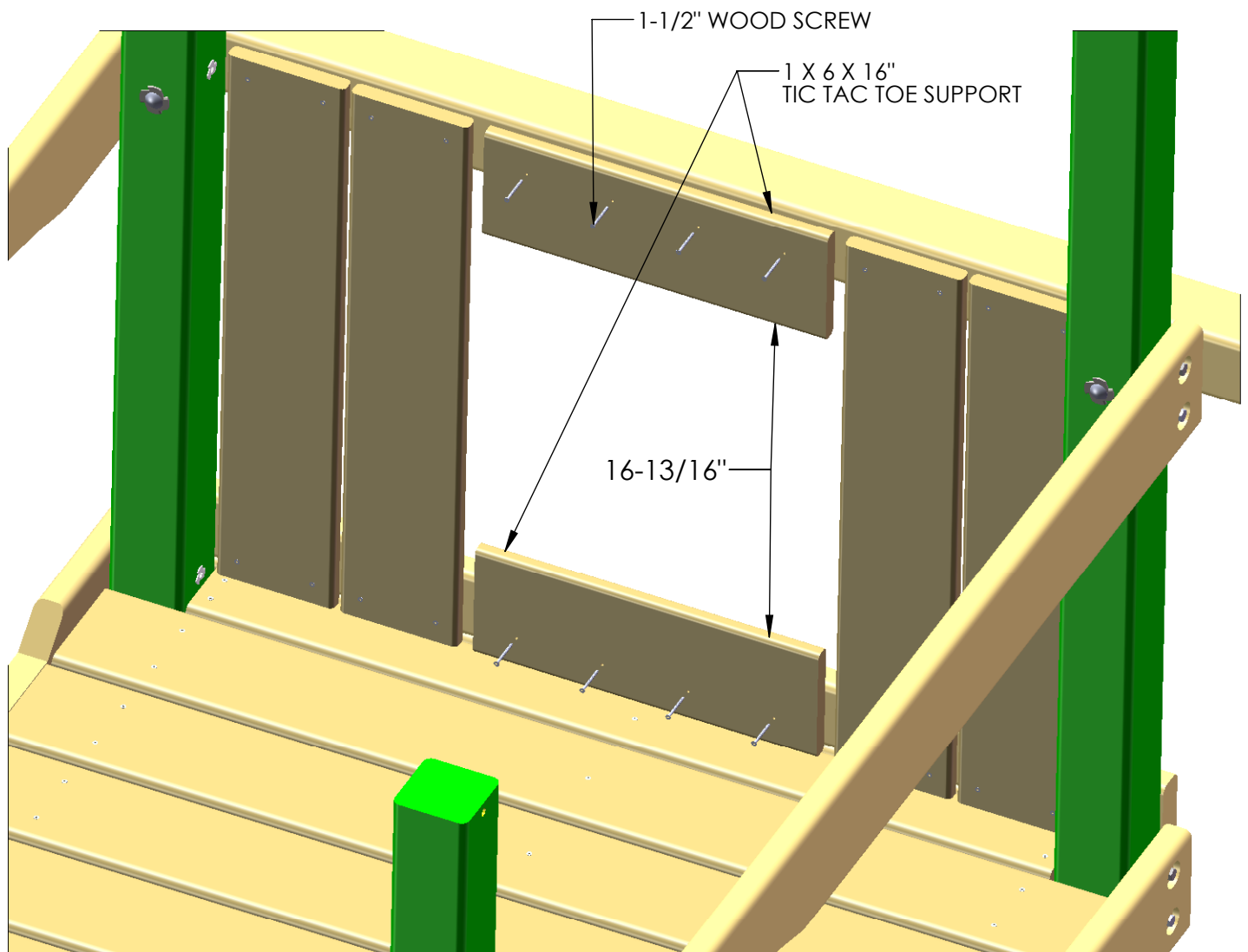
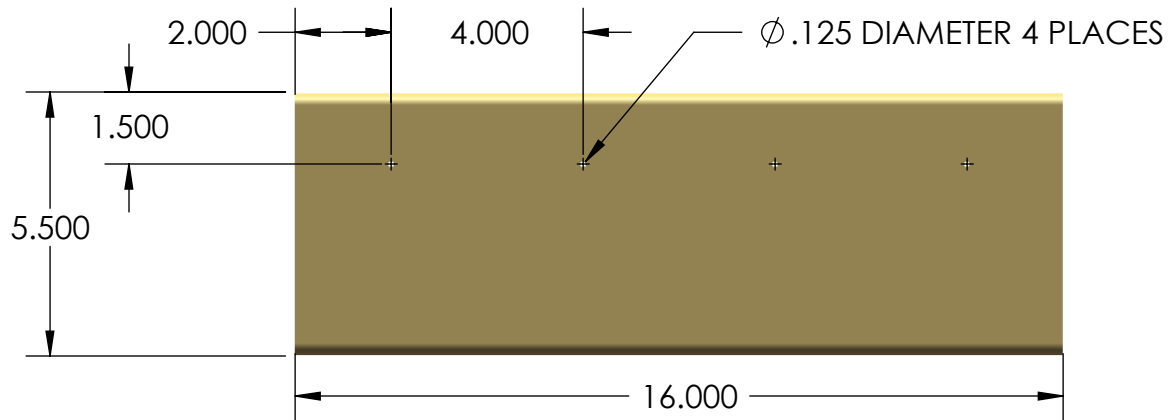

STEP 22: SWING BEAM PLATE

1: PLACE THE SWING BEAM PLATE ON TOP OF THE SWING BEAM SUPPORT, LINING UP THE PILOT HOLES.

2: FASTEN THE SWING BEAM PLATE TO THE SWING BEAM SUPPORT USING 3-1/2" CARRIAGE BOLTS ON THE TOP, AND 3/8" WASHERS, 3/8" LOCK NUTS ON THE BOTTOM, IN THE COUNTER-SUNK HOLES OF THE SWING BEAM SUPPORT. USE BOLT CAPS TO COVER ANY EXPOSED THREADS.

3: LEAVE THE MIDDLE HOLE EMPTY, IT WILL BE USED LATER.

4: IF NECESSARY USE VICE GRIPS TO HOLD CARRIAGE BOLTS IN PLACE WHEN INSTALLING.

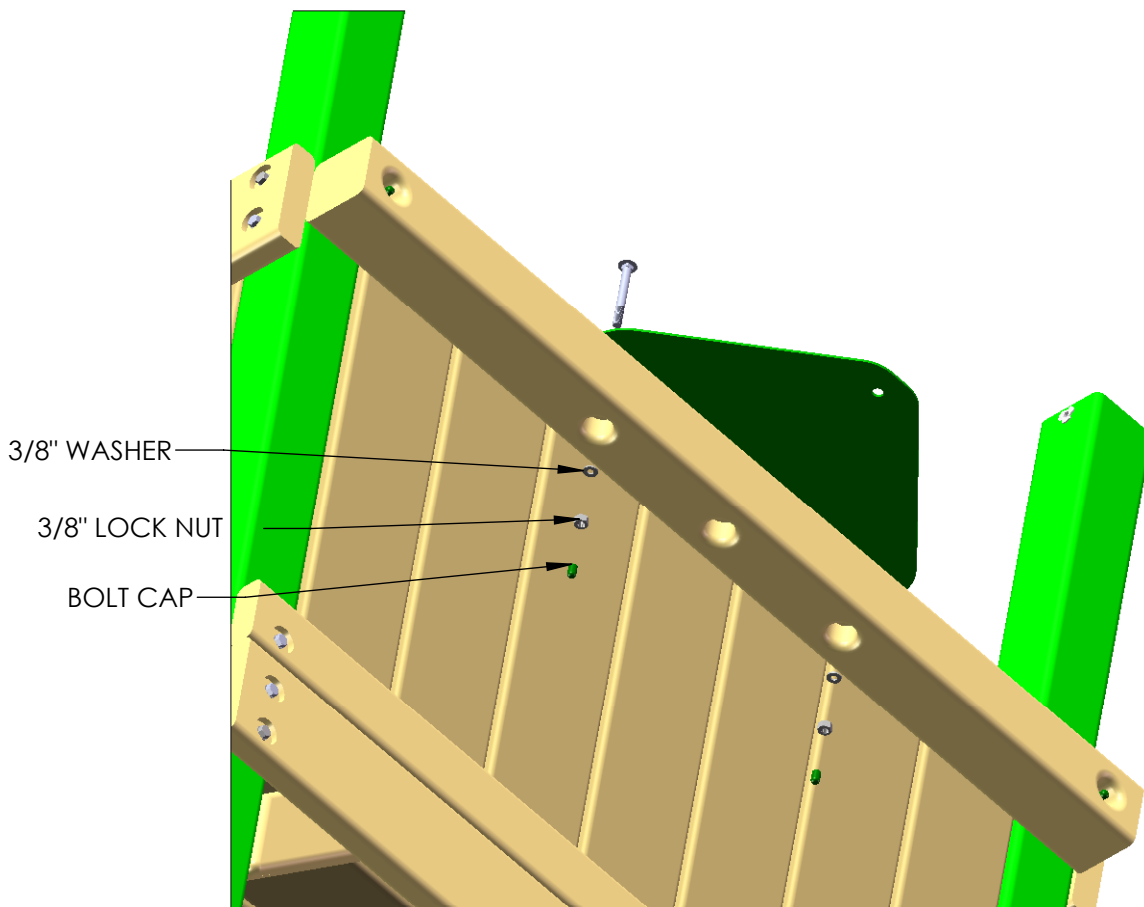
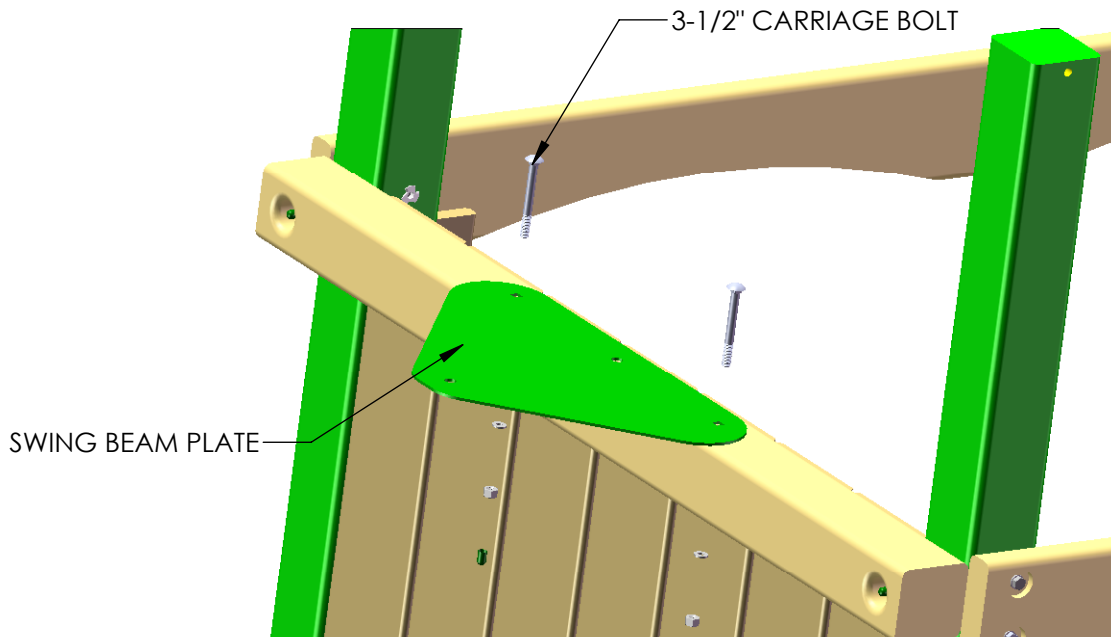

STEP 23: IRON DUCTILES

1: LINE UP THE HOLES OF THE IRON DUCTILES WITH THE HOLES IN THE SWINGBEAM.

2: FASTEN THE SWING HANGER TO THE SWING BEAM USING 7" CARRIAGE BOLTS WITH TORQUE WASHERS, AND 3/8" WASHERS WITH 3/8" LOCK NUTS.

3: PLACE BOLT CAPS OVER EXPOSED THREADS.

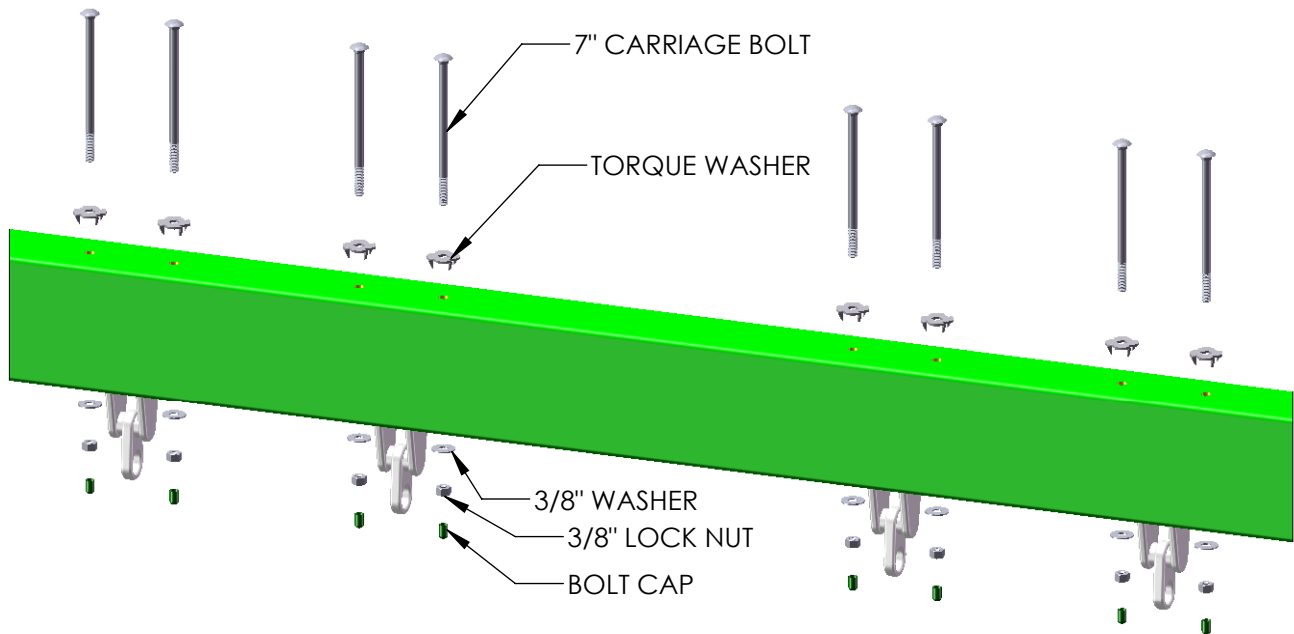

STEP 24: ATTACH SWING LEGS TO BRACKET

1: PLACE THE 4 X 4 X 108" SWING LEGS FLUSH TO THE TOP OF THE SWING LEG BRACKET.

2: FASTEN THE SWING LEGS TO THE SWING LEG BRACKET WITH 3/8 X 3-1/2" LAG SCREWS AND 3/8" WASHERS.

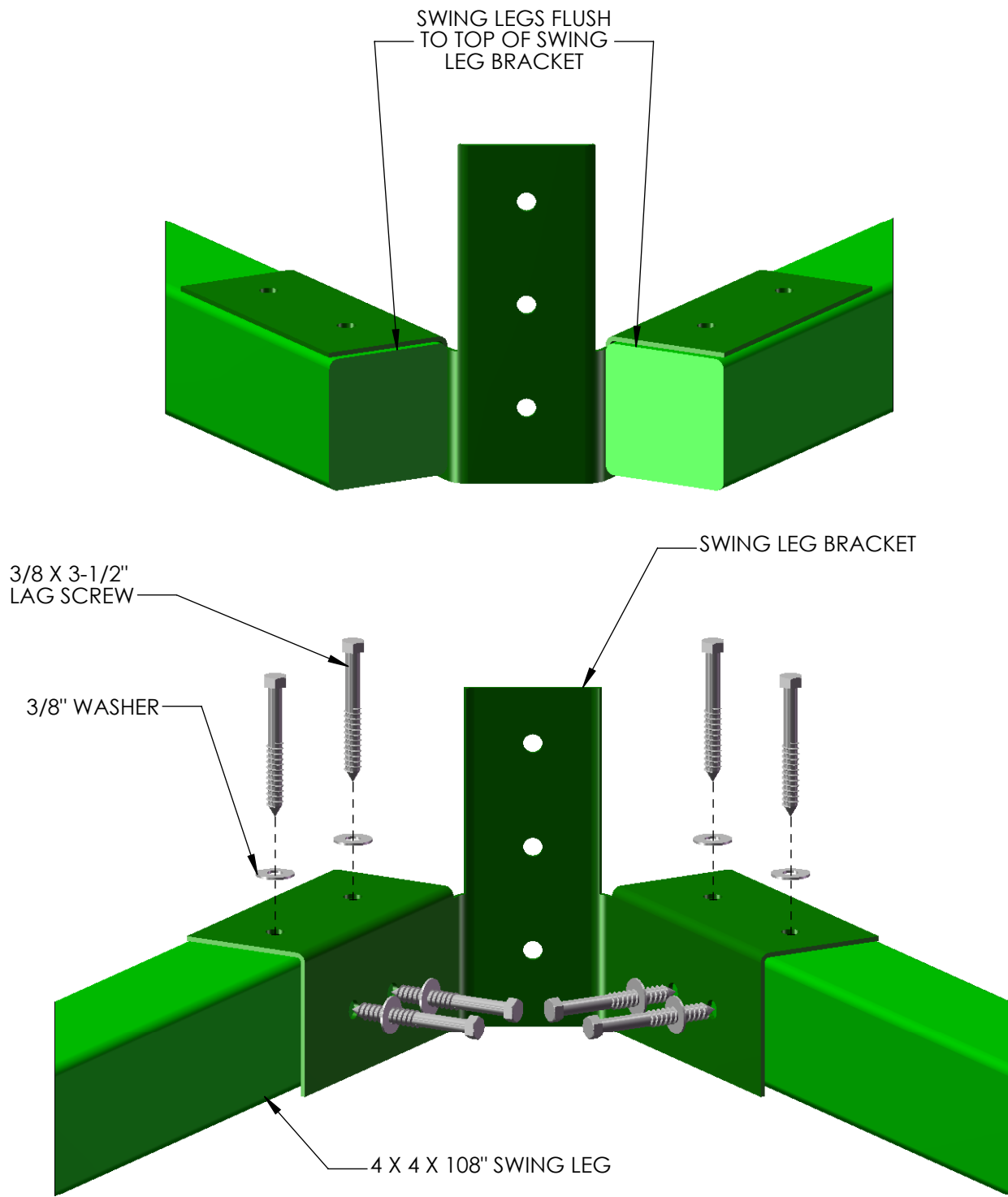

STEP 25: MOUNT SWING BEAM TO SWING BEAM LEGS

1: FASTEN THE SWING BEAM TO THE SWING BEAM BRACKET USING 7" CARRIAGE BOLTS WITH TORQUE WASHERS ON TOP OF THE SWING BEAM, AND 3/8" LOCK NUTS WITH 3/8" WASHERS FROM UNDERNEATH.

2: USE A 3/8" X 3-1/2" LAG SCREW WITH 3/8" WASHER FOR THE HOLE IN THE CENTER OF THE SWING BEAM BRACKET.

3: PLACE A BOLT CAP OVER ANY EXPOSED THREADS.

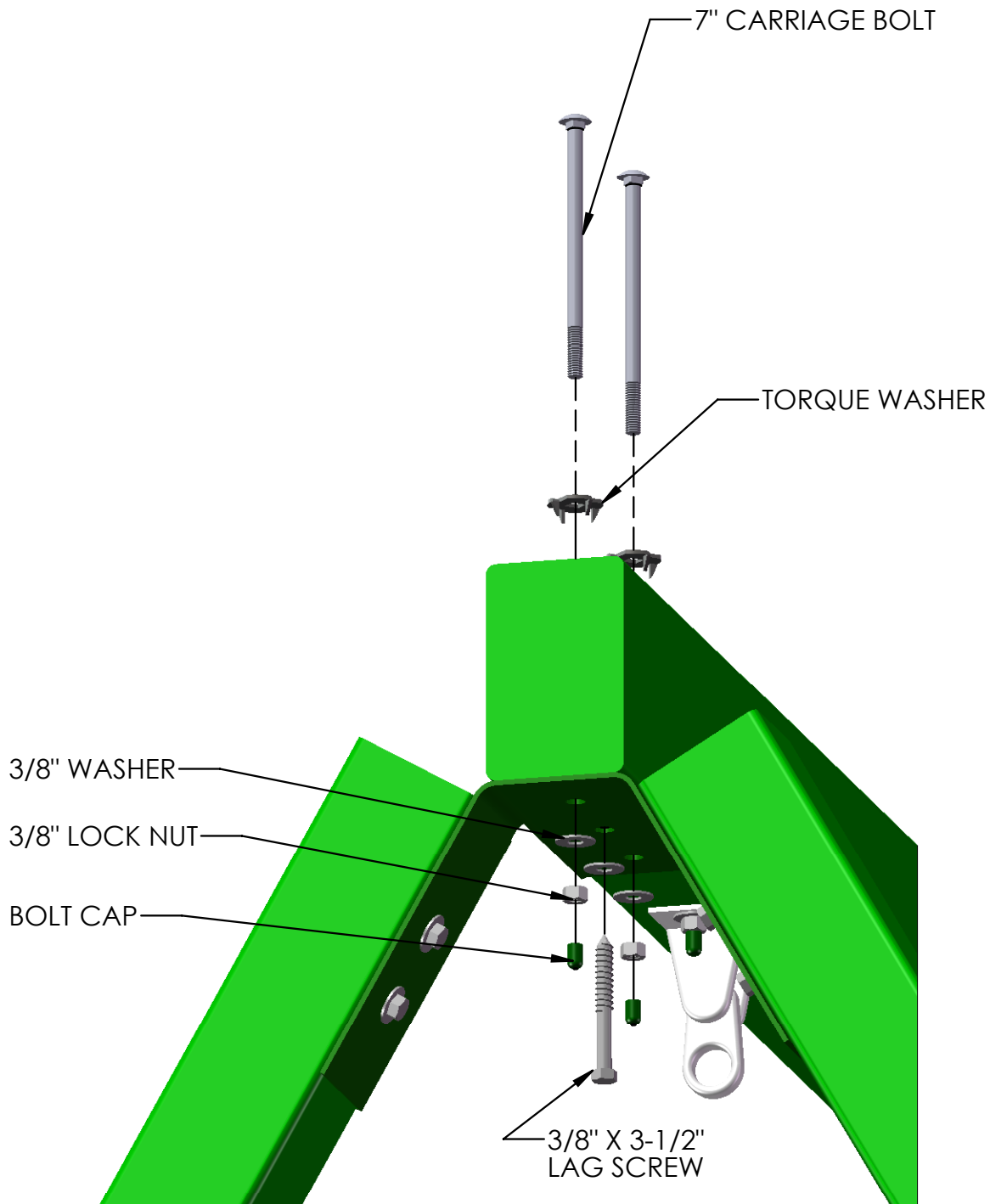

STEP 26: MOUNT SWING BEAM TO FORT

AN EXTRA PERSON IS NEEDED FOR THIS STEP.

1: HAVE ONE PERSON WALK THE SWING BEAM OUT TO THE END OF THE FORT FROM INSIDE THE FORT WHILE THE OTHER PERSON CARRIES IT BY THE LEGS.

2: LINE UP THE PILOT HOLES AT THE END OF THE SWING BEAM WITH THE MIDDLE HOLES ON THE SWING BEAM PLATE.

3: FASTEN THE SWING BEAM TO THE SWING BEAM PLATE AND SWING BEAM SUPPORT USING A 9" CARRIAGE BOLT WITH A TORQUE WASHER ON TOP, AND A 3/8" LOCK NUT AND WASHER ON THE BOTTOM. PLACE BOLT CAPS OVER EXPOSED THREADS AFTER SECURING.

4: FASTEN THE SWING BEAM TO THE SWING BEAM PLATE FROM UNDERNEATH WITH A 3/8 X 3-1/2" LAG SCREW AND 3/8" WASHER.

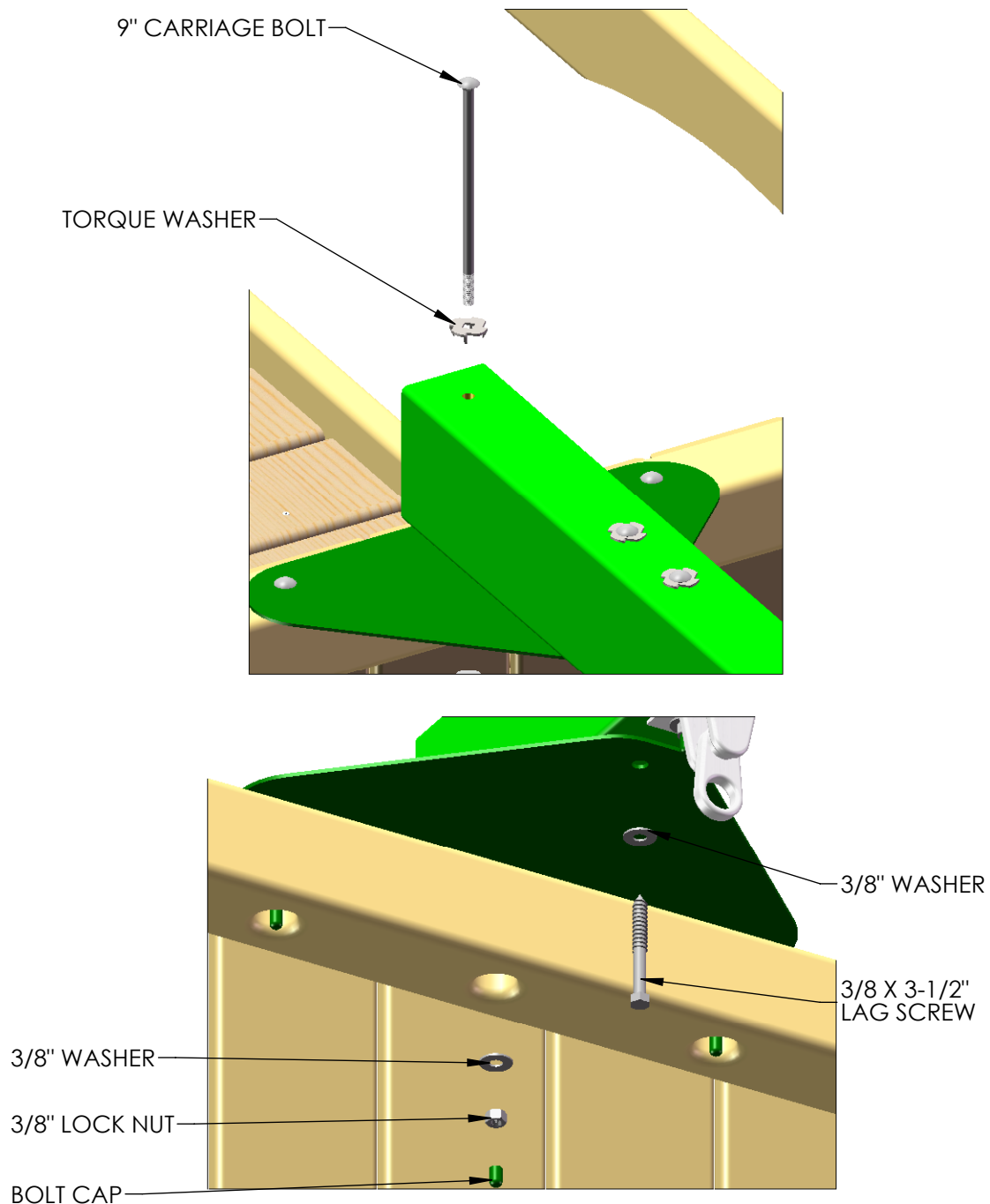

STEP 27: LEVEL SWING BEAM

1: PLACE A LEVEL ON TOP OF THE SWING BEAM AND ADJUST THE BEAM LEGS IN OR OUT AS NEEDED TO MAKE THE SWING BEAM LEVEL.

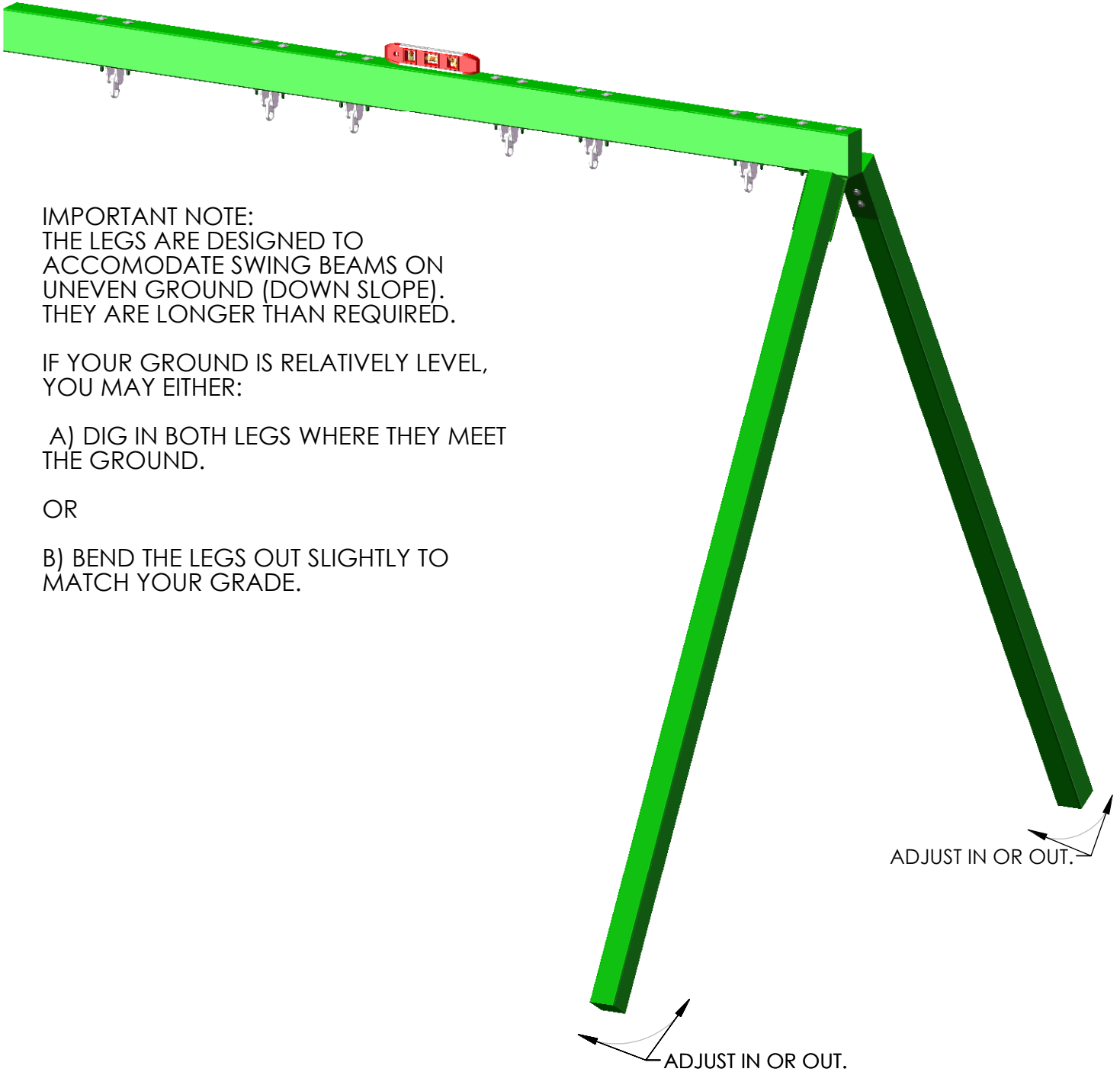

IMPORTANT NOTE:
THE LEGS ARE DESIGNED TO
ACCOMODATE SWING BEAMS ON
UNEVEN GROUND (DOWN SLOPE).
THEY ARE LONGER THAN REQUIRED.

IF YOUR GROUND IS RELATIVELY LEVEL,
YOU MAY EITHER:

A) DIG IN BOTH LEGS WHERE THEY MEET
THE GROUND.

OR

B) BEND THE LEGS OUT SLIGHTLY TO
MATCH YOUR GRADE.

STEP 28: SWING LEG CROSS-MEMBER

1: POSITION THE 2 X 4 X 58" SWING LEG CROSS-MEMBER AGAINST THE SWING BEAM LEGS.

2: LEVEL THE CROSS-MEMBER AND MARK THE LOCATION OF THE SECURING HOLES INSIDE THE CROSS-MEMBER HOLES.

3: USE 3/8" X 3-1/2" LAG SCREWS WITH 3/8" WASHERS TO SECURE THE CROSS-MEMBER TO THE SWING BEAM LEGS.

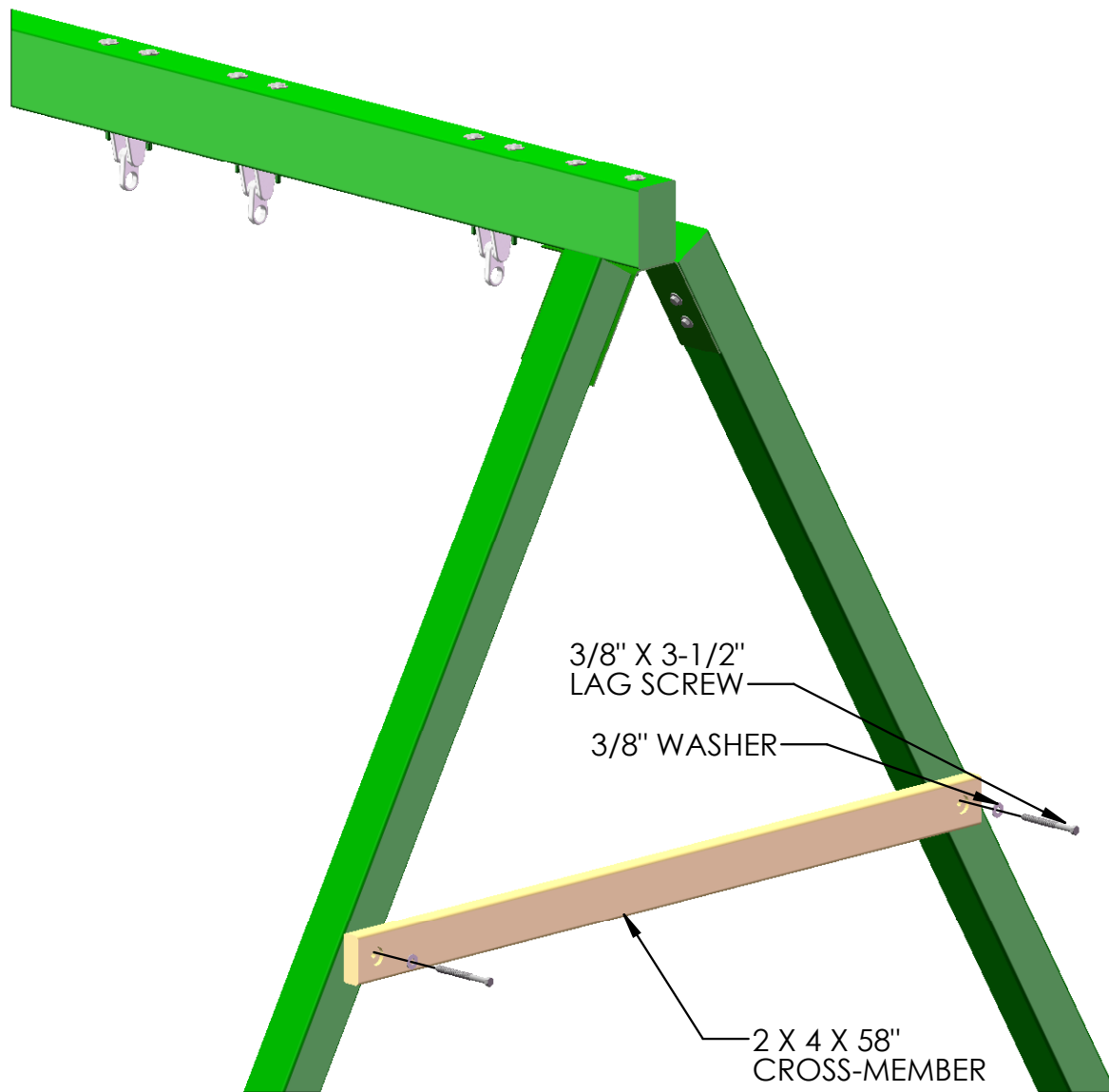

STEP 29: ROOF SUPPORT

1: WITH OFFSET HOLES DOWN, ATTACH THE 2 X 4 X 51" ROOF SUPPORTS TO THE FORT WITH 5/16" X 4-1/2" HEX BOLTS. THE ROOF SUPPORTS SHOULD MEET IN THE MIDDLE TO FORM A RIGHT ANGLE.

2: DO NOT CONNECT THE ENDS AT THIS TIME.

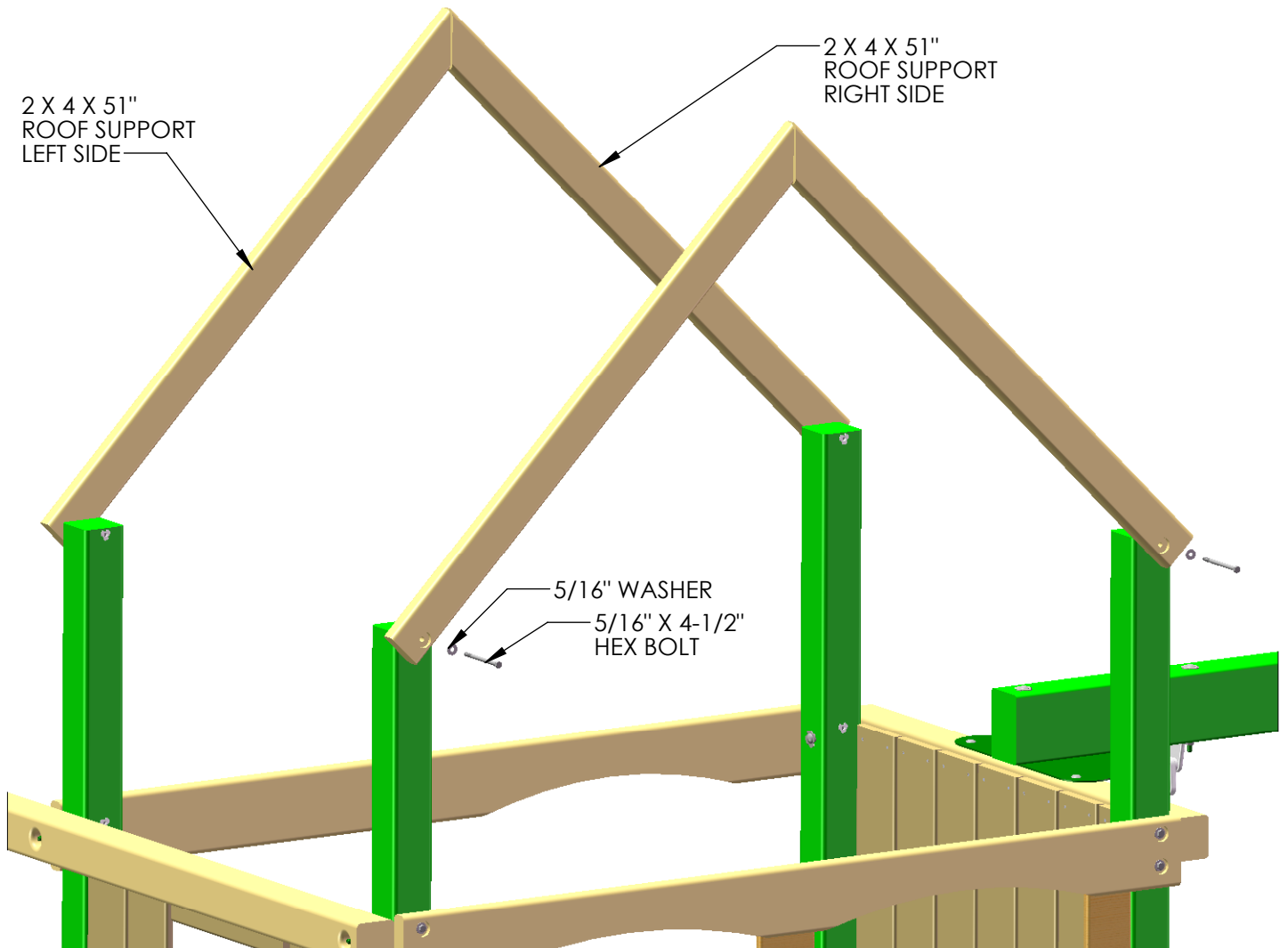

STEP 30: ROOF PEAK SUPPORT

1: PRE-DRILL HOLES IN THE TWO 5/4 X 10" ROOF PEAK SUPPORTS TO THE PATTERN SHOWN BELOW.

5/4 X 10"
ROOF PEAK
SUPPORT

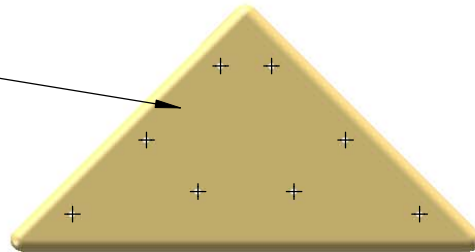

2: PLACE THE 5/4 X 10" ROOF PEAK SUPPORT AGAINST THE ANGLED ROOF SUPPORTS AND FLUSH TO THE SIDES OF THE ANGLED ROOF SUPPORTS. FASTEN THE ROOF PEAK SUPPORT TO THE ANGLED ROOF SUPPORTS WITH 1-1/2" WOOD SCREWS. REPEAT ON OTHER SIDE.

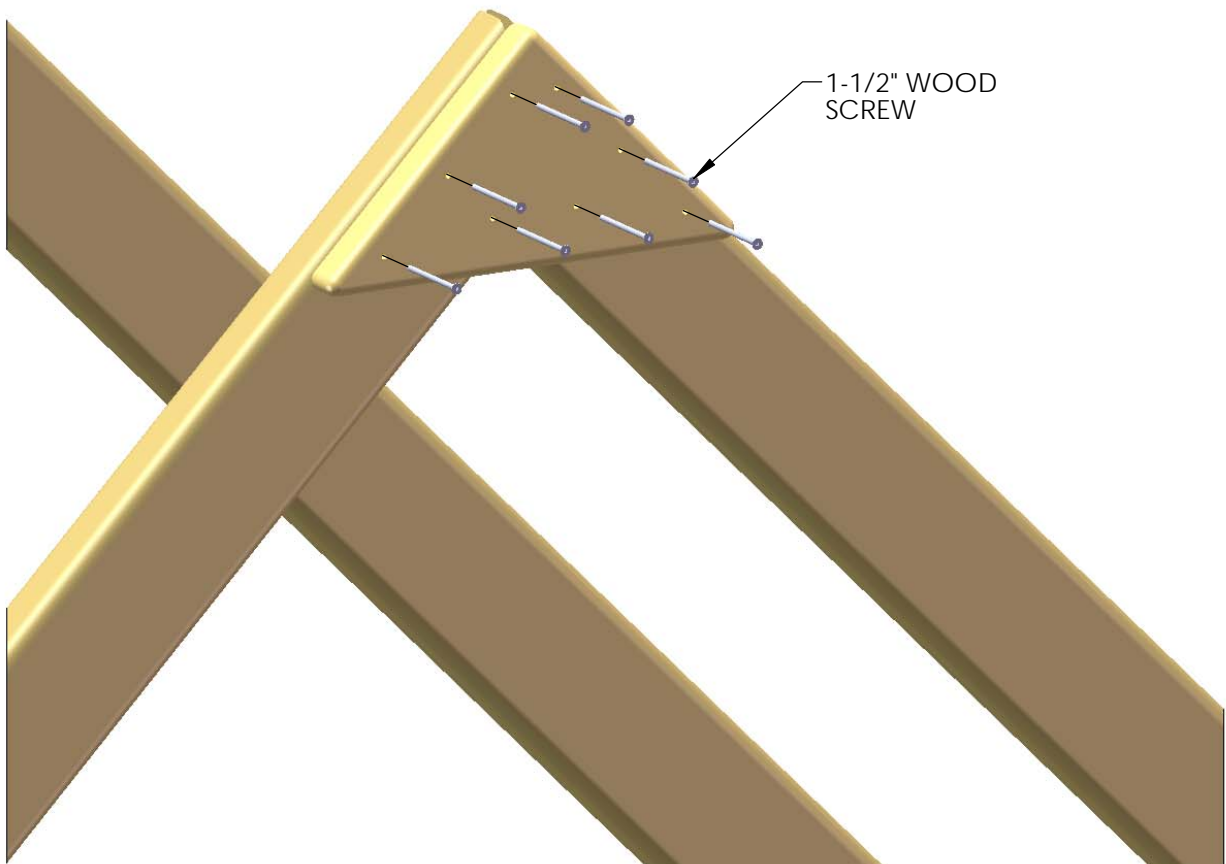

STEP 31: ROOF

1: PLACE THE 1 X 5 X 55" GROOVE-ONLY ROOF STARTER BOARDS AT THE PEAK OF THE ROOF. THE HOLES IN THE ROOF STARTERS SHOULD BE CENTERED ON THE ROOF SUPPORTS, AND THE FLAT ENDS OF THE ROOF STARTERS SHOULD BE PLACED AS CLOSE TO EACH OTHER AS POSSIBLE WITHOUT THE BOARDS OVERLAPPING.

2: FASTEN THE ROOF STARTER BOARDS TO THE ROOF SUPPORTS WITH 1-1/2" WOOD SCREWS.

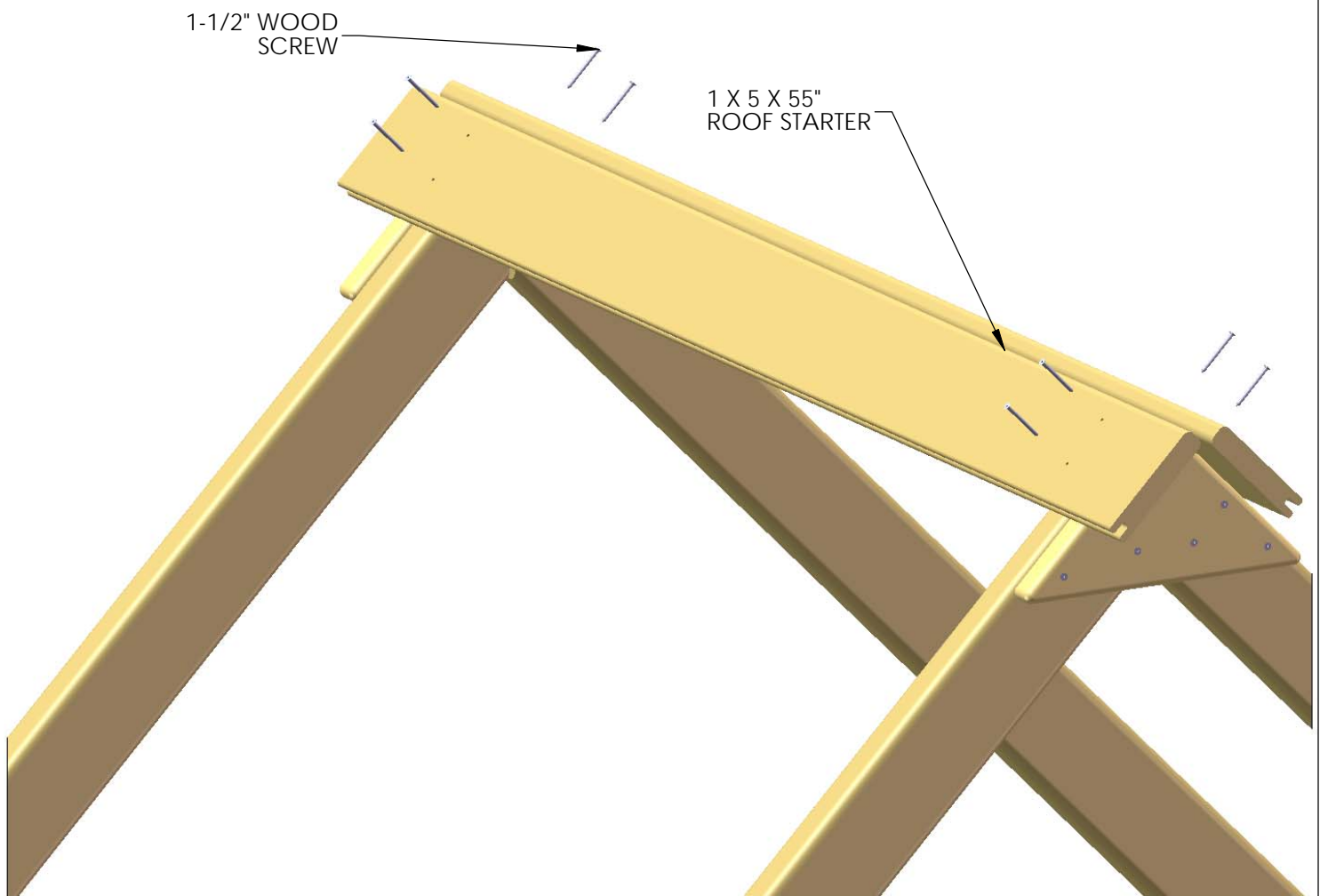

STEP 32: ROOF PEAK

1: PLACE THE 55" ROOF PEAK ON TOP OF THE ROOF STARTER BOARDS.

2: FASTEN THE ROOF PEAK TO THE ROOF STARTER BOARDS WITH EIGHT 1-1/2" WOOD SCREWS.

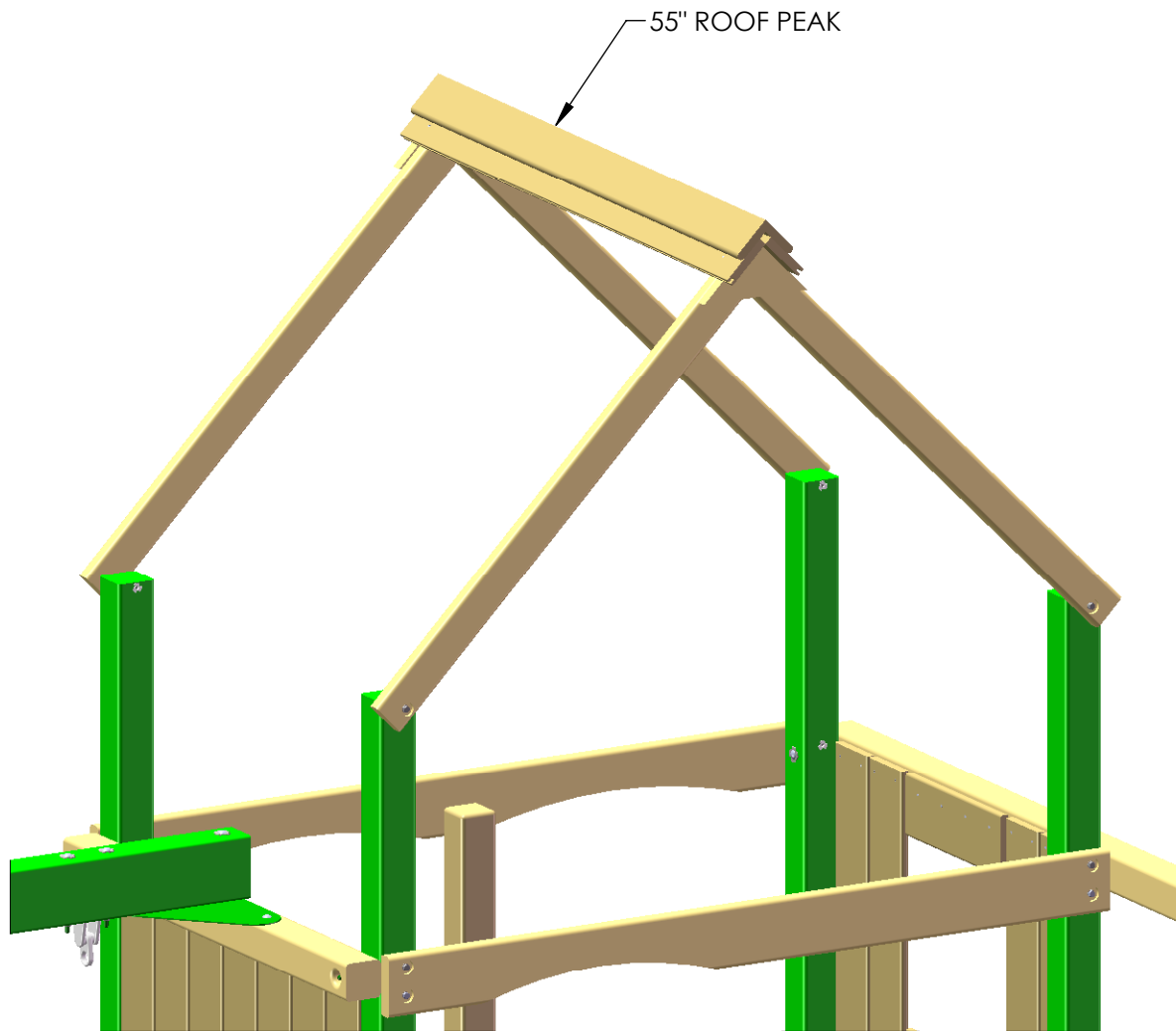

STEP 33: ROOF

- 1: PLACE THE 1 X 6 X 55" ROOF BOARDS ON TOP OF THE ROOF SUPPORTS, FITTING THE TONGUE INTO THE GROOVE END OF THE ROOF STARTERS. EACH SIDE OF THE ROOF GETS NINE ROOF BOARDS.
2. FASTEN THE ROOF BOARDS TO THE ROOF SUPPORTS WITH 1-1/2" WOOD SCREWS.
- 3: PLACE A 1 X 5 X 55" ROOF FINISHER AT THE END OF THE ROOF ASSEMBLY, AND FASTEN WITH 1-1/2" WOOD SCREWS. EACH SIDE OF THE ROOF GETS ONE ROOF FINISHER.
- 4: REPEAT SUBSTEPS 1-3 FOR THE OTHER SIDE OF THE ROOF.

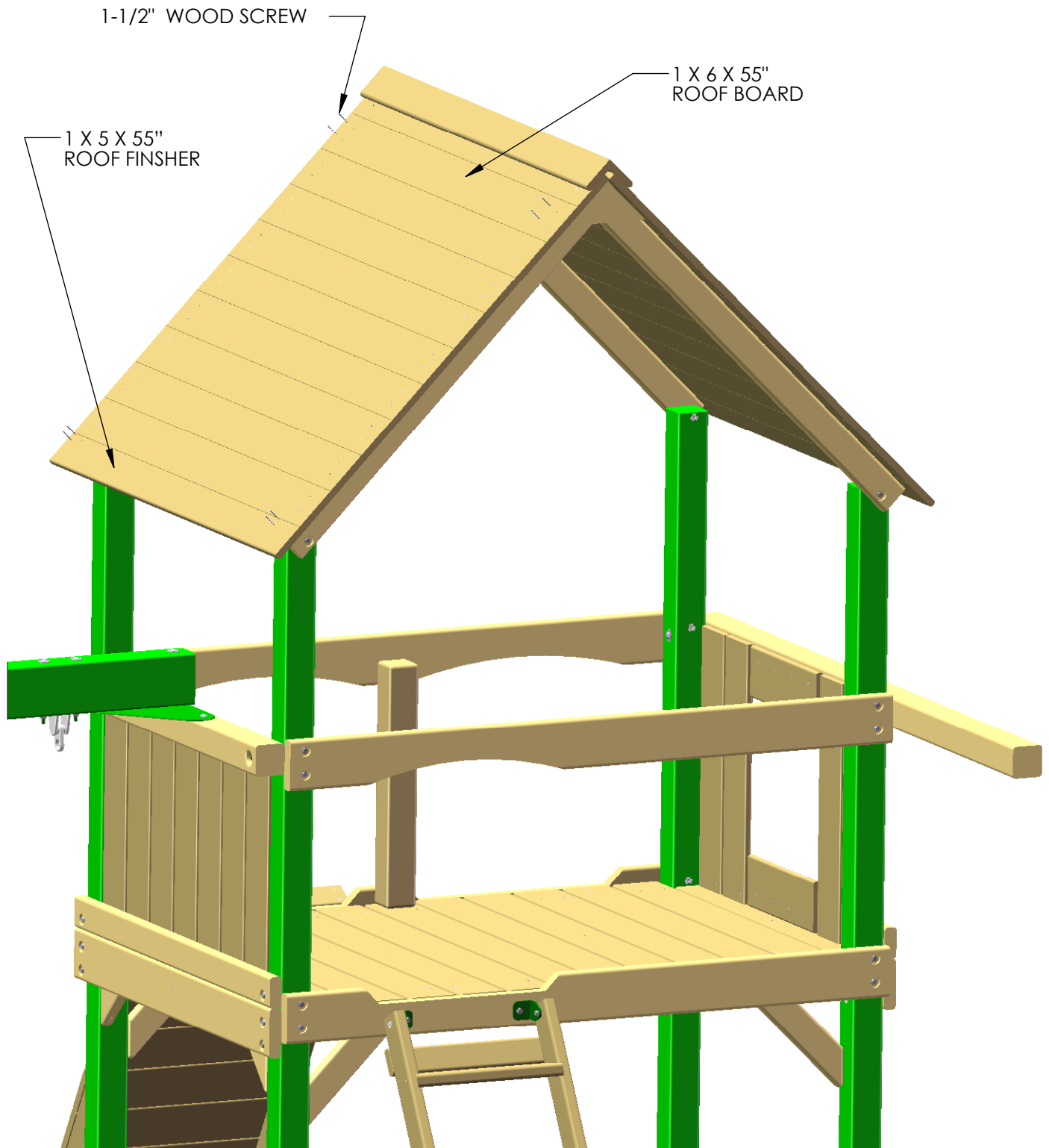

STEP 34: SUNBURST BOARD

1: FIND TWO 2 X 6 X 56-1/2" SUNBURST BOARDS.

2: PRE-DRILL A HOLE ON BOTH ENDS OF THE BOARD AT A 45 DEGREE ANGLE THROUGH THE BOARD AT 1-1/4" FROM THE END OF THE BOARD WITH A 1/8" DRILL BIT.

3: PLACE BOARD IN BETWEEN THE ROOF SUPPORTS.

4: INSTALL USING 2" WOOD SCREWS.

ROOF PANELS REMOVED FOR CLARITY.

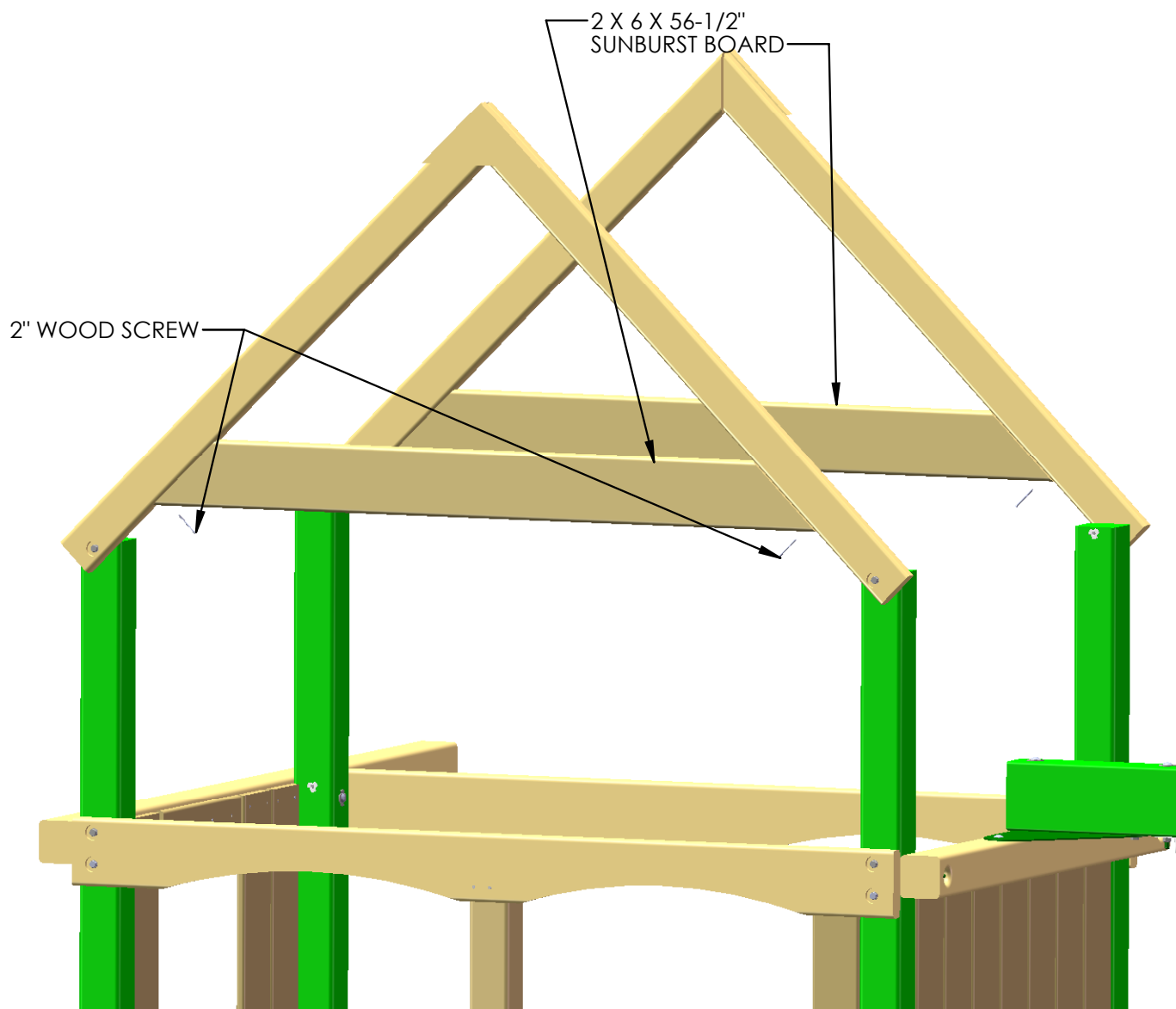

STEP 35: BOTTOM SUNBURST BOARD

1: FIND TWO 2 X 6 X 67-1/4" SUNBURST BOARDS.

2: PRE-DRILL A HOLE ON BOTH ENDS OF THE BOARD AT A 45 DEGREE ANGLE THROUGH THE BOARD AT 1-1/4" FROM THE END OF THE BOARD WITH A 1/8" DRILL BIT.

3: PLACE BOARD IN BETWEEN THE ROOF SUPPORTS.

4: INSTALL USING 2" WOOD SCREWS.

ROOF BOARDS REMOVED FOR CLARITY.

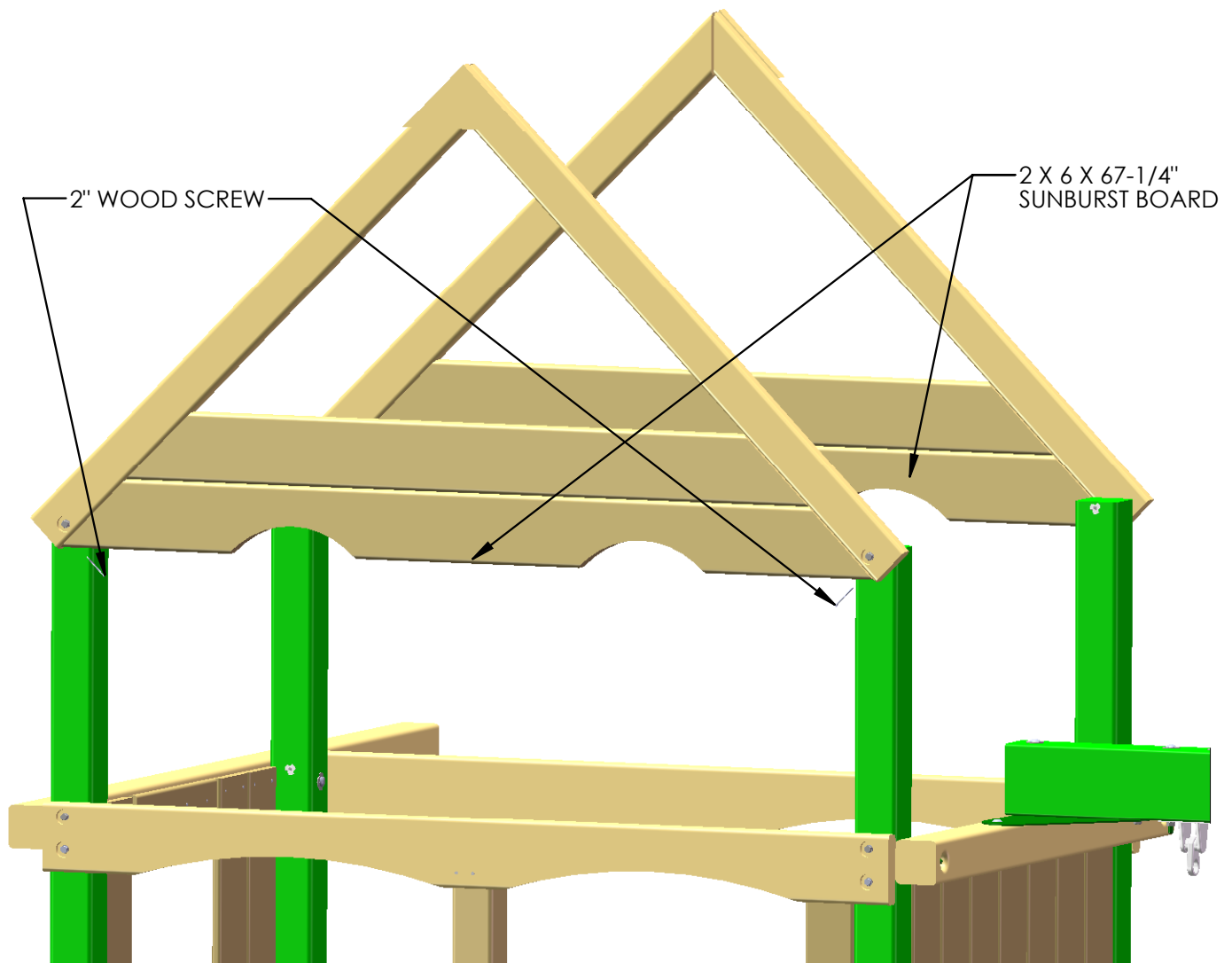

STEP 36: FRONT TOP PANEL SLATS

- 1: FIND SIX 1 X 6 X 26" AND TWO 1 X 4 X 26" FRONT PANEL SLATS.
- 2: PRE-DRILL THE SLATS 1" FROM EACH END WITH TWO HOLES EQUALLY SPACED WITH A 1/8" DRILL BIT.
- 3: INSTALL THE PANEL SLATS AT THE DIMENSIONS SHOWN ON THE DIAGRAM.
- 4: ATTACH THE SLATS TO THE FORT WITH 1-1/2" WOOD SCREWS IN THE PRE-DRILLED HOLES.

ROOF PANELS REMOVED FOR CLARITY.

VIEW WITH DIMENSIONS IS FROM REAR OF FORT LOOKING FORWARD.

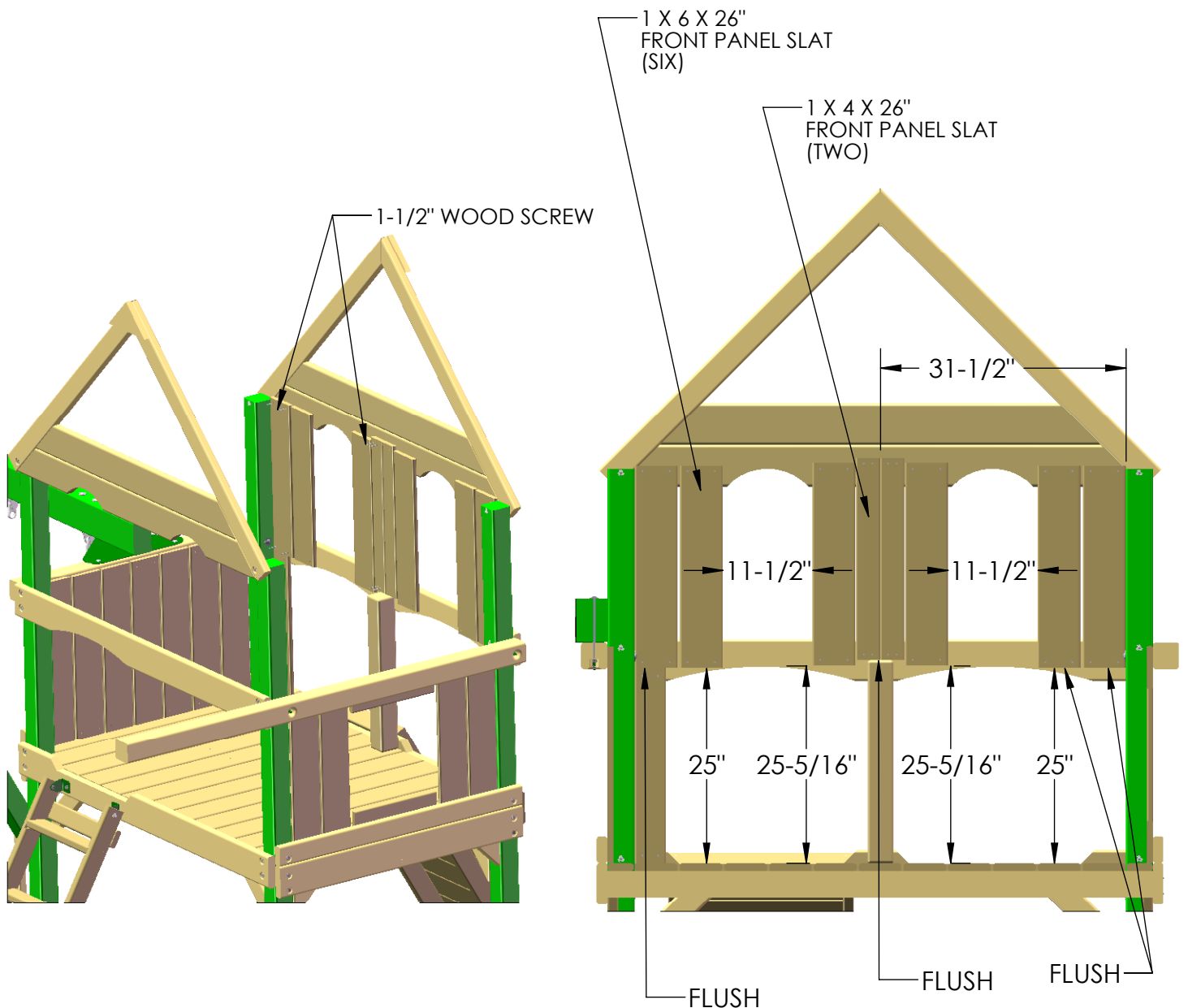

STEP 37: REAR PANEL SLATS

- 1: FIND FOUR 1 X 6 X 51" REAR PANEL SLATS AND TWO 1 X 4 X 51" REAR PANEL SLATS.
 - 2: PRE-DRILL THE SLATS 1" FROM EACH END WITH TWO HOLES EQUALLY SPACED WITH A 1/8" DRILL BIT
 3. INSTALL THE PANEL SLATS AS SHOWN BELOW.
 - 4: ATTACH THE PANEL SLATS TO THE FORT WITH 1-1/2" WOOD SCREWS IN THE PRE-DRILLED HOLES.
 - 5: ONCE THE PANEL SLATS ARE INSTALLED DRILL TWO HOLES IN THE MIDDLE OF EACH SLAT AND ATTACH TO THE REAR TOP PANEL BOARD WITH 1-1/2" WOOD SCREWS.
- ROOF PANELS REMOVED FOR CLARITY.

VIEW WITH DIMENSIONS IS FROM FRONT OF FORT LOOKING TOWARDS REAR.

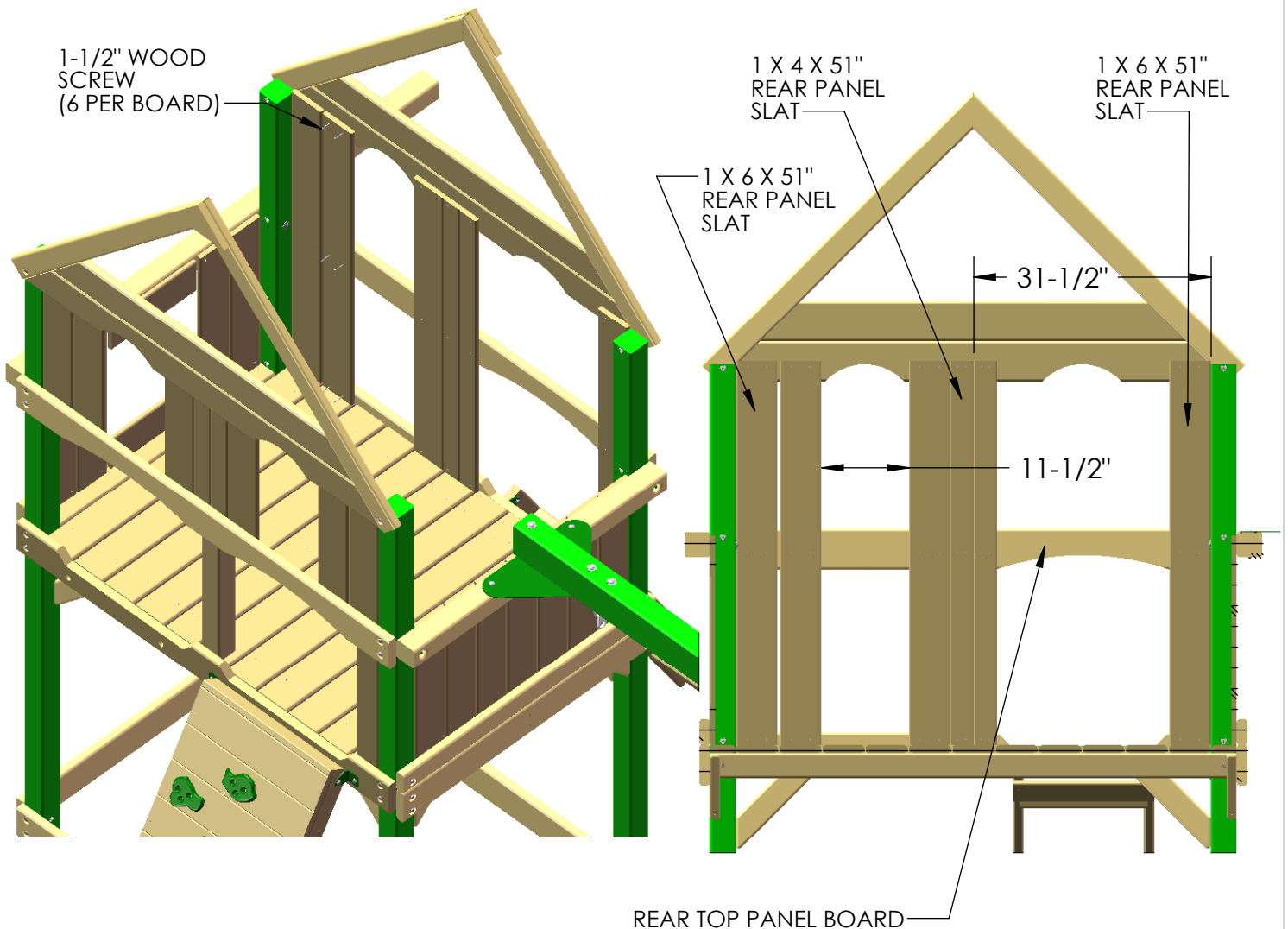

STEP 38: FINAL REAR PANEL BOARDS

- 1: FIND TWO 1 X 6 X 29-1/2" BOTTOM WINDOW SUPPORT BOARDS AND TWO 1 X 6 X 26" FRONT PANEL SLATS.
- 2: PRE-DRILL THE 1 X 6 X 29-1/2" BOTTOM WINDOW SUPPORT BOARDS 3/4" FROM THE BOTTOM END AND 4" FROM THE TOP END WITH TWO HOLES EQUALLY SPACED WITH A 1/8" DRILL BIT.
- 3: INSTALL THE BOTTOM WINDOW SUPPORT BOARDS 5/16" OFF THE DECK AND SPACE THEM EQUALLY IN THE OPENING. ATTACH THE BOARDS WITH 1-1/2" WOOD SCREWS.
- 4: PRE-DRILL THE 1 X 6 X 26" FRONT PANEL SLATS 1" FROM EACH END WITH TWO HOLES EQUALLY SPACED WITH A 1/8" DRILL BIT.
- 5: INSTALL THE LEFT 1 X 6 X 26" FRONT PANEL SLAT 25-5/16" OFF THE DECK AND ATTACH WITH 1-1/2" WOOD SCREWS. INSTALL THE RIGHT 1 X 6 X 26" FRONT PANEL SLAT 25" OFF THE DECK AND ATTACH WITH 1-1/2" WOOD SCREWS. BE SURE TO LEAVE AT LEAST AN 11-1/2" GAP BETWEEN THE SLATS AS SHOWN BELOW.

ROOF PANELS REMOVED FOR CLARITY.

VIEW WITH DIMENSIONS IS FROM FRONT OF FORT LOOKING TOWARDS REAR.

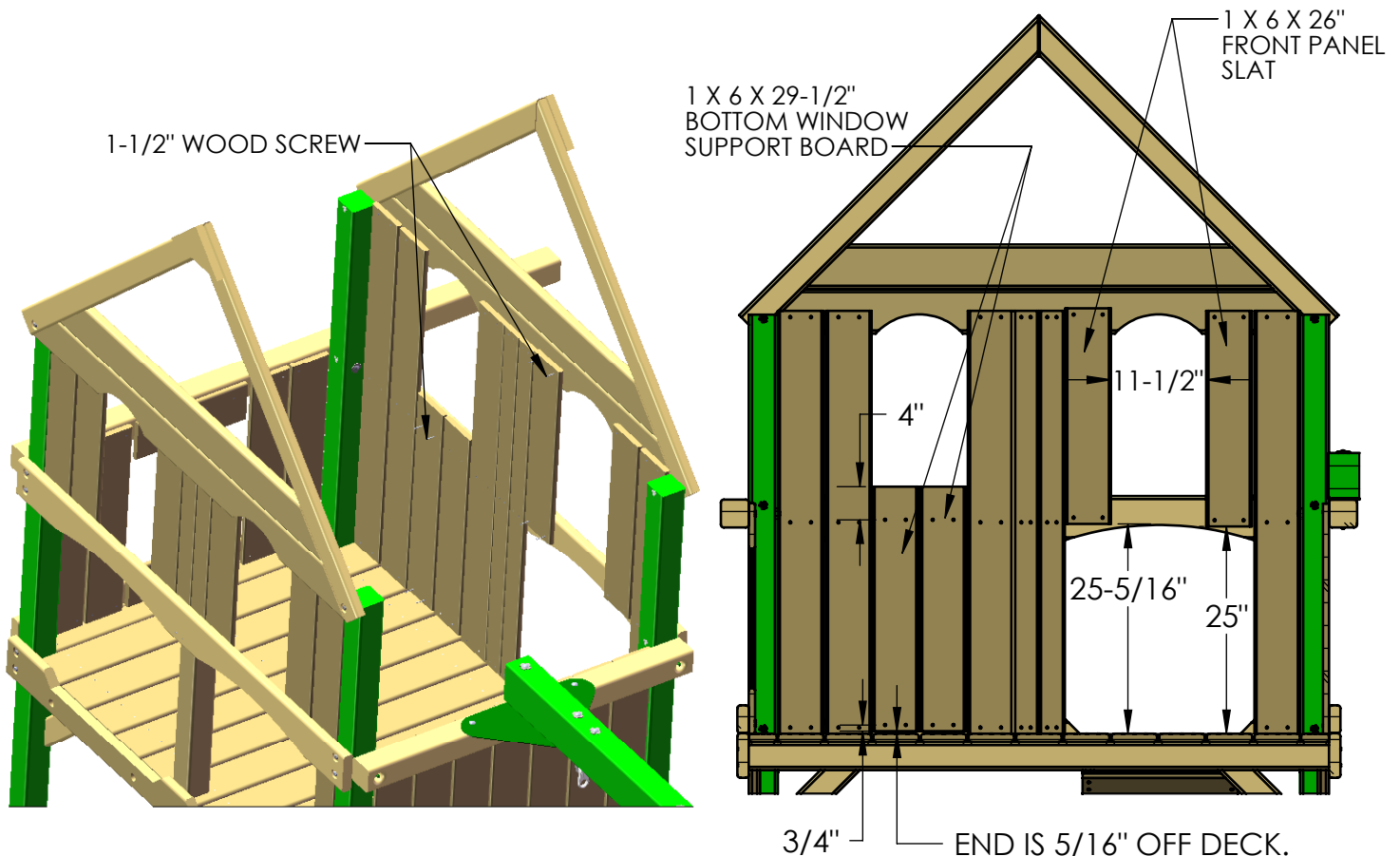

STEP 39: WINDOW SUPPORTS

1: FIND THE SIX 1 X 6 X 4-1/2" BOTTOM WINDOW SUPPORTS. PRE-DRILL THREE 1/8" HOLES IN THE BOTTOM OF EACH SUPPORT AS SHOWN IN THE DIAGRAM.

2: PLACE TWO SUPPORTS IN EACH OF THE TWO OPENINGS IN THE FRONT OF THE FORT, AND THE FINAL TWO SUPPORTS IN THE OPENING AT THE REAR OF THE FORT. THE SUPPORTS SHOULD BE FLUSH WITH THE BOTTOM OF THE CENTER MOUNTED 1 X 6 X 26" FRONT PANEL SLATS AS SHOWN BELOW.

3: ATTACH EACH SUPPORT USING THREE 1-1/2" WOOD SCREWS.

ROOF PANELS REMOVED FOR CLARITY.

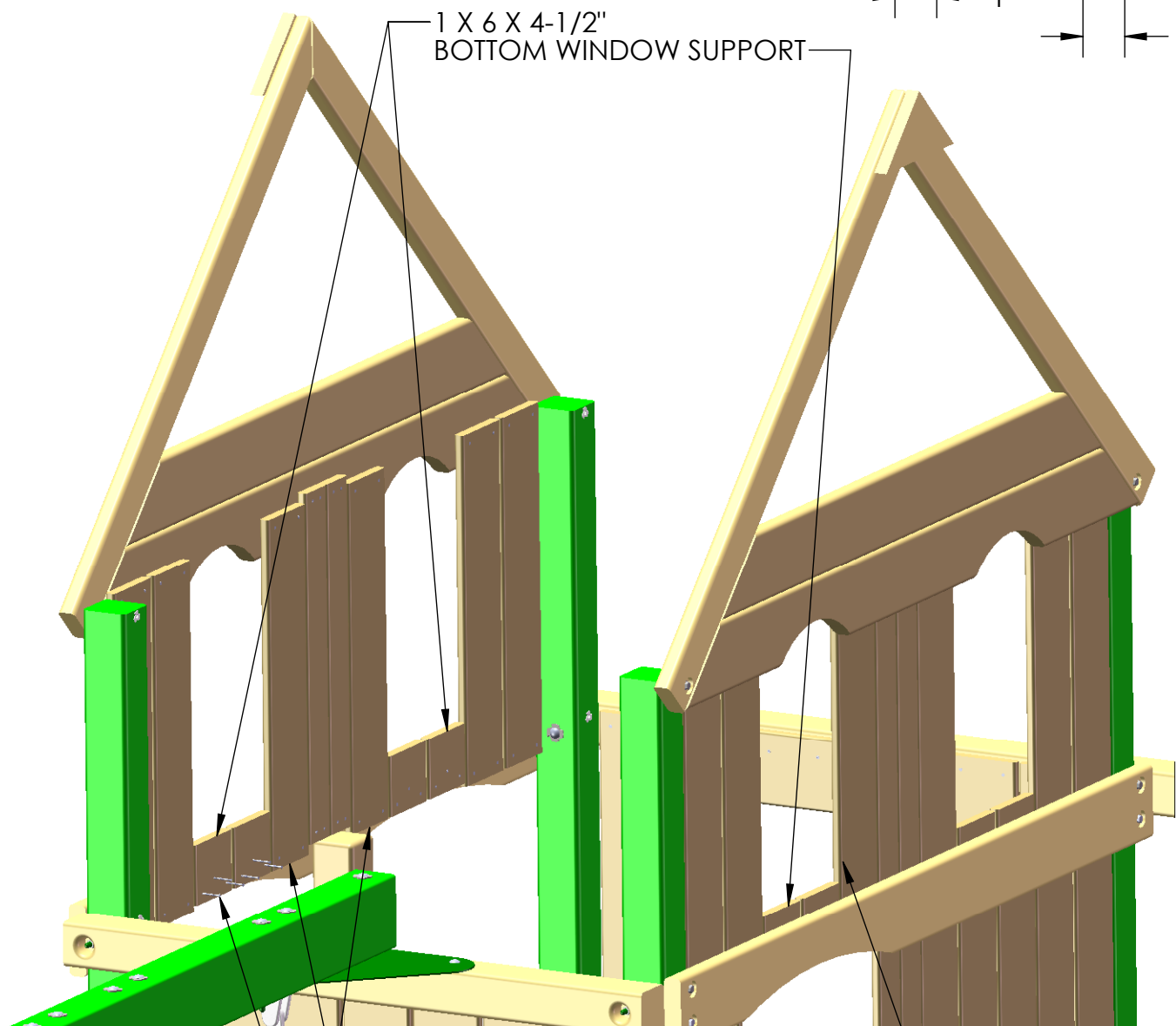
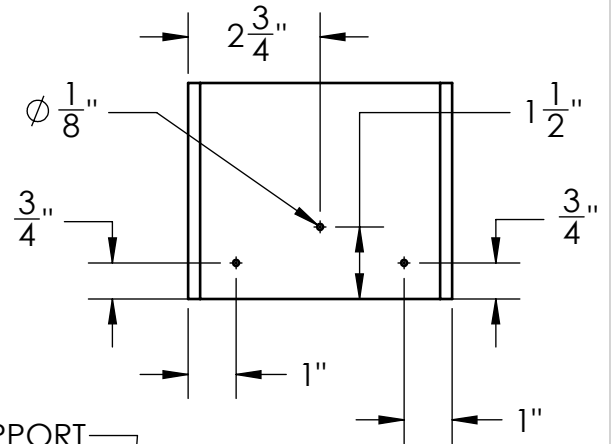

1-1/2"
WOOD SCREW

MAKE SUPPORTS FLUSH WITH BOTTOM
OF 1 X 6 X 26" FRONT PANEL SLATS.

STEP 40: INSTALL WINDOWS

1: FIND FOUR WINDOW PANELS AND FOUR SUN PIECES. PLACE EACH WINDOW IN THE OPENING WITH THE 1" WIDE SECTION OF THE WINDOW FRAME AT THE TOP. TEST FIT THE SUN PIECES ABOVE THE WINDOW FRAME (THESE WILL BE INSTALLED LATER).

2: ATTACH EACH WINDOW WITH FOUR #8 X 1-1/4" WOOD SCREWS.

ROOF PANELS REMOVED FOR CLARITY.

TOP OF FRAME IS 1"

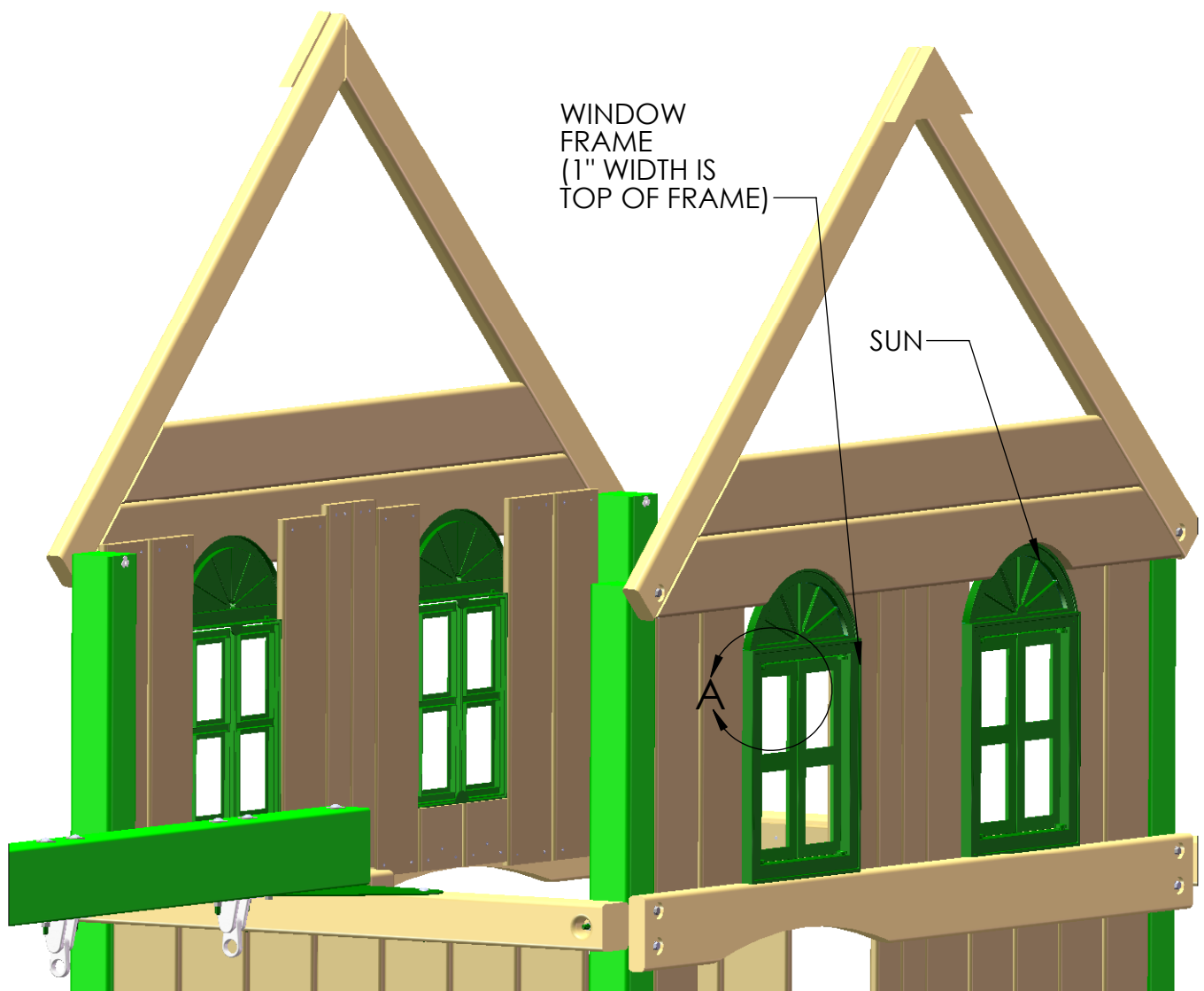
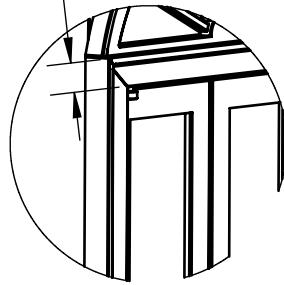

STEP 41: INSTALL PANEL SLATS AND SUN PIECES

- 1: FIND EIGHT 1 X 6 X 14-1/4" FRONT PANEL SLATS AND EIGHT SUN PIECES.
 - 2: PRE-DRILL EACH SLAT WITH A 1/8" DRILL BIT AT THE DIMENSIONS SHOW BELOW.
 - 3: ATTACH THE PANEL SLATS AS SHOWN BELOW WITH THE BOTTOM OF THE SLAT RESTING UPON THE INSIDE FLANGE OF THE WINDOW FRAME.
 - 4: ATTACH THE PANEL SLATS TO THE FORT WITH 1-1/2" WOOD SCREWS IN THE PRE-DRILLED HOLES.
 - 5: ATTACH FOUR MORE PANEL SLATS ON THE REAR SIDE.
 - 6: ATTACH ONE SUN PIECE TO THE PANEL SLATS WITH TWO #8 X 1" WOOD SCREWS ABOVE EACH WINDOW.
- ROOF PANELS REMOVED FOR CLARITY.

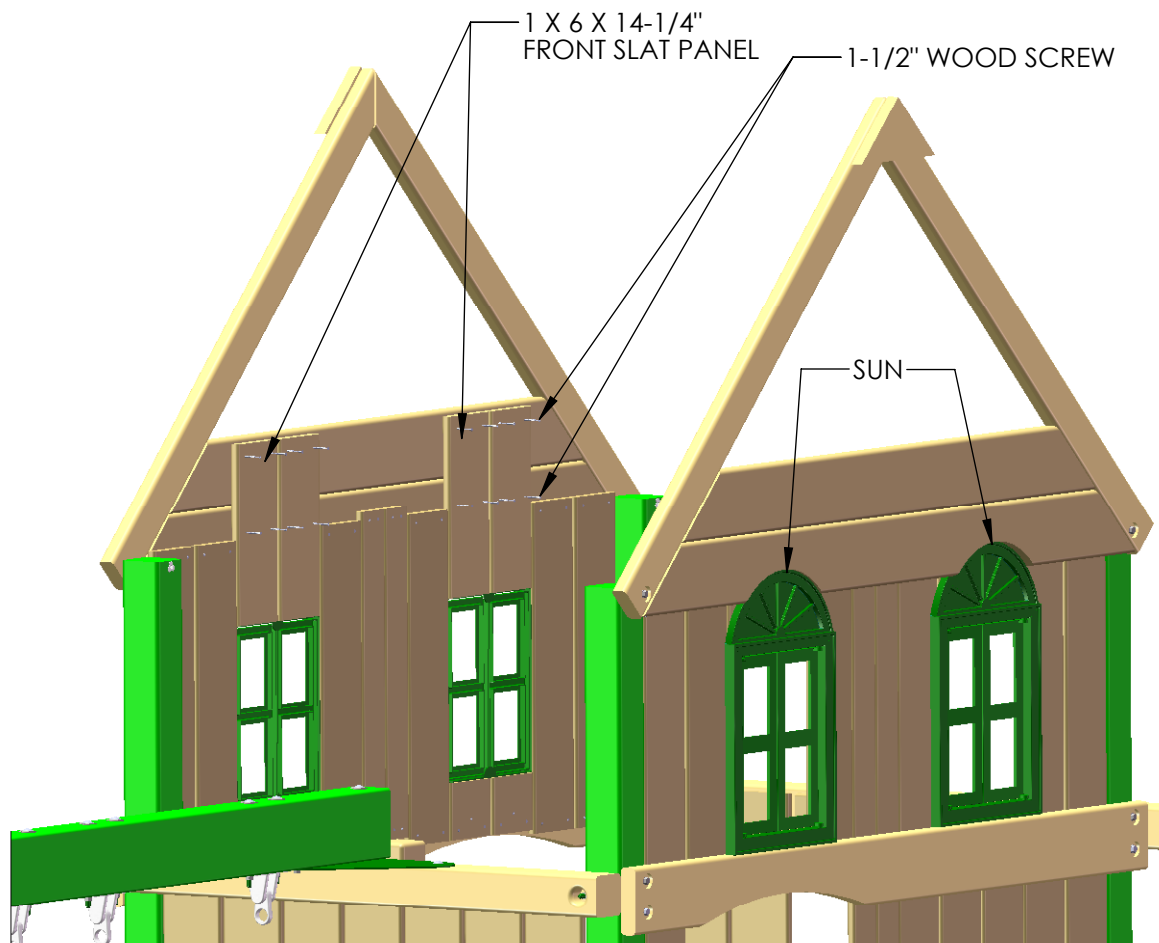
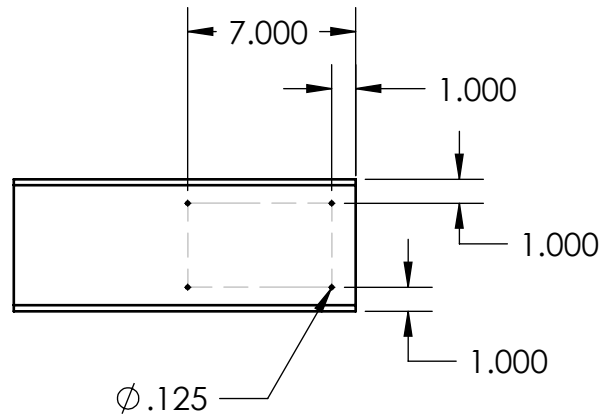

STEP 42: TIC TAC TOE PANEL

1: ASSEMBLE THE TIC TAC TOE PANEL ACCORDING TO THE INSTRUCTIONS IN THE BOX. DISREGARD STEPS 6 & 7.

2: CENTER THE TIC TAC TOE PANEL BETWEEN THE SUPPORTS ON THE SIDE WALL AND ATTACH WITH EIGHT 1" WOOD SCREWS PROVIDED IN THE TIC TAC TOE BOX.

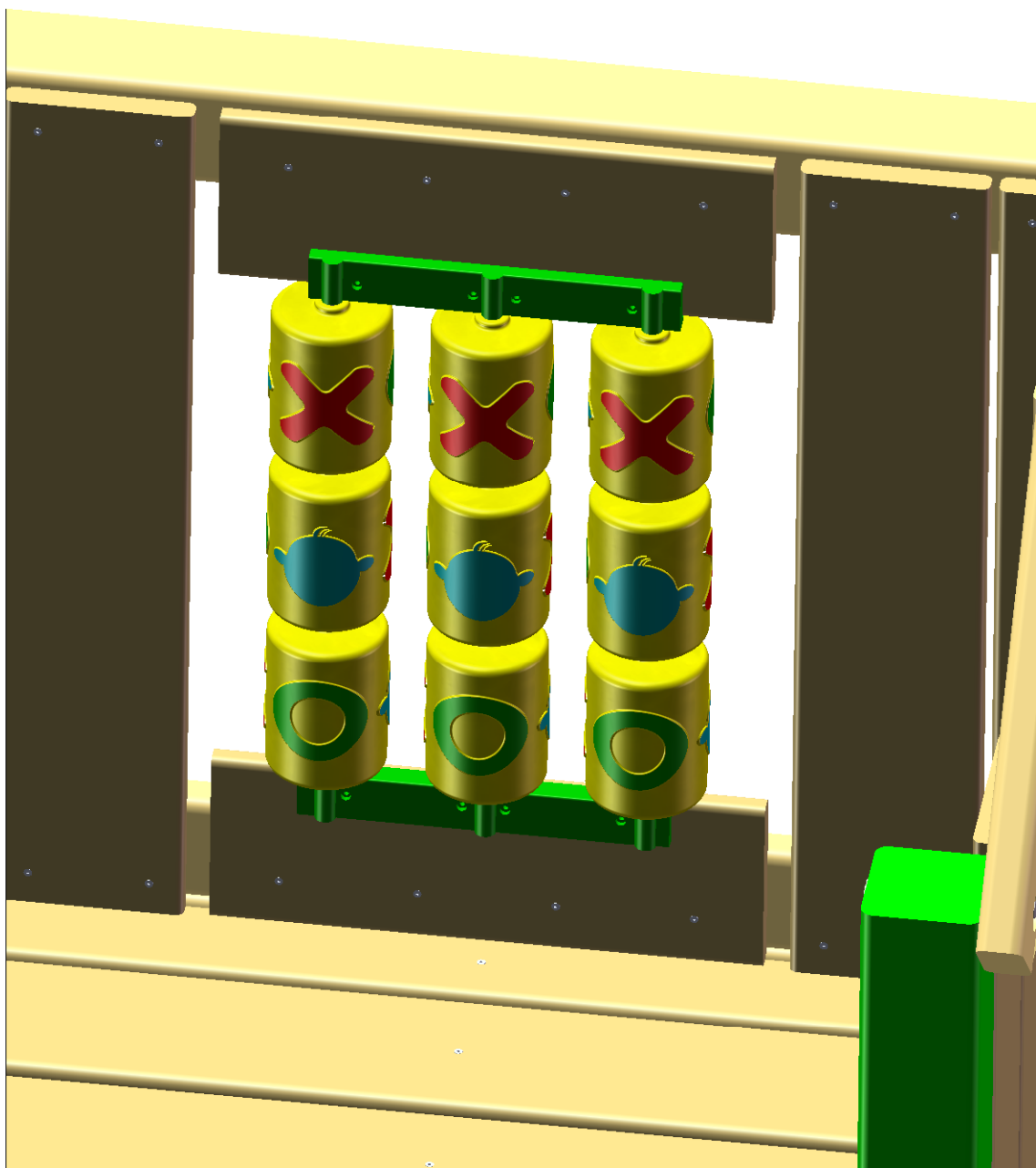

STEP 43: SUNBURST

- 1: PRE-DRILL TWO 1/8" HOLES IN EACH SUN. THE HOLES WILL BE DRILLED NEAR THE OUTER EDGE ON EACH SIDE GOING STRAIGHT DOWN.
- 2: CENTER SUN ON THE PANEL BOARD AND ATTACH USING TWO 2" WOOD SCREWS.
- 3: REPEAT FOR OTHER SIDE OF FORT.

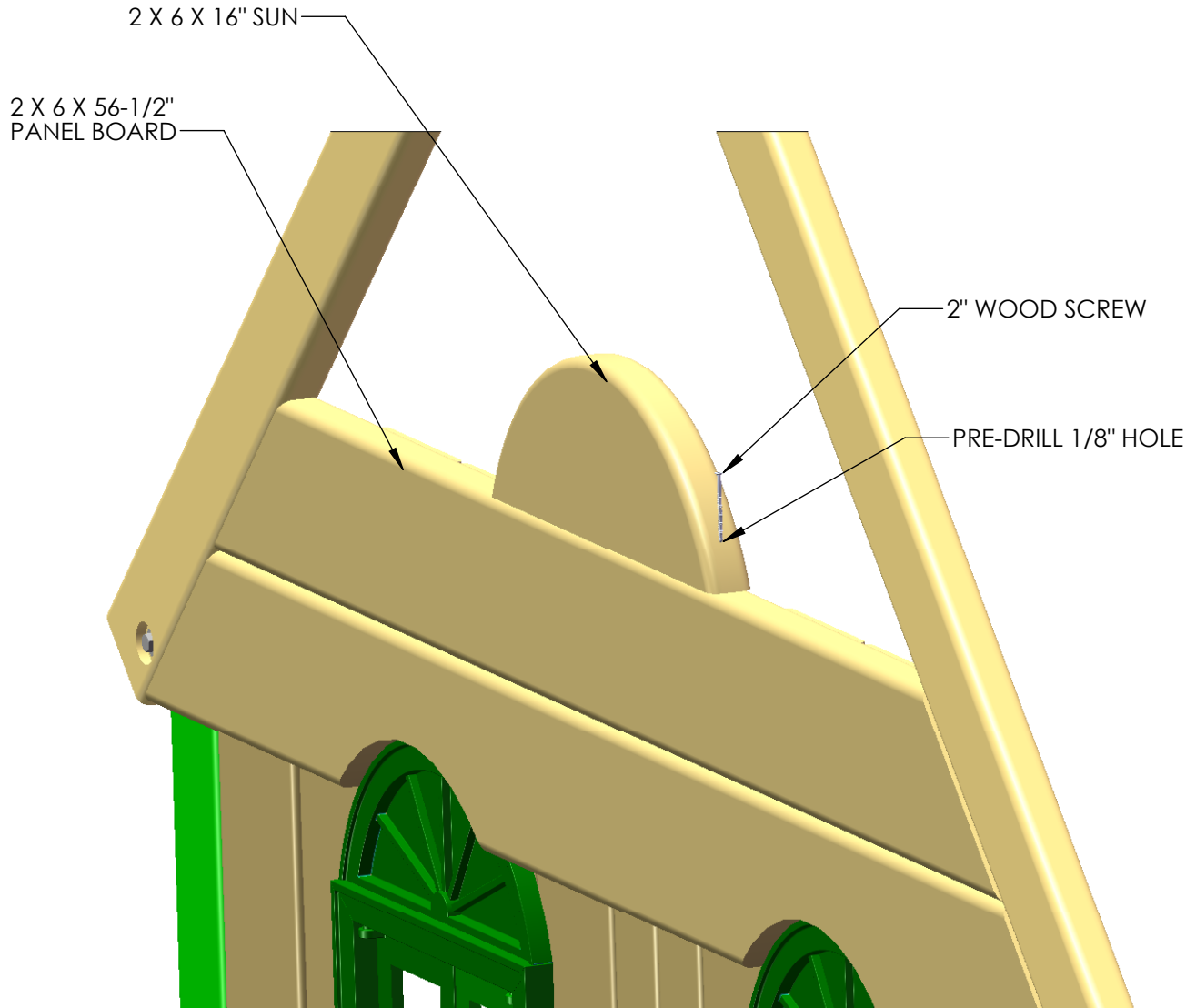

STEP 44: SUNBURST

1: LOCATE TWO 5/4 X 2 X 23" LARGE RAYS, TWO 5/4 X 2 X 16" SMALL RAYS AND TWO 5/4 X 2 X 18" SMALL RAYS.

2: PRE-DRILL ALL SMALL RAYS AT 3/4" ON CENTER FROM EACH END WITH A 1/8" DRILL BIT.

PRE-DRILL ALL LARGE RAYS 3/4" ON CENTER FROM THE BOTTOM END WITH A 1/8" DRILL BIT. PRE-DRILL THE TOP END 3/4" FROM THE TOP END AND 1/2" FROM THE SIDE WITH A 1/8" DRILL BIT. (SEE DETAIL A) THIS IS NECESSARY TO AVOID HITTING THE JOINT WHERE THE ROOF SUPPORTS MEET.

3: CENTER THE 5/4 X 2 X 23" LARGE SUNRAY ONTO THE SUN AND THE ROOF SUPPORT BOARDS AND FASTEN WITH TWO 1-1/2" SCREWS.

4: EQUALLY SPACE THE SMALL RAYS ABOUT THE SUN (THREE ON EACH SIDE OF LARGE RAY) AND MARK THE POSITION OF THE SMALL RAYS WITH A PENCIL.

5: SECURE THE SMALL RAYS ONE AT A TIME TO THE SUN AND THE ROOF SUPPORTS AND LINE THEM UP WITH THE MARK DRAWN. FASTEN THE SMALL RAYS WITH TWO 1-1/2" WOOD SCREWS EACH. REPEAT ON OTHER SIDE OF FORT.

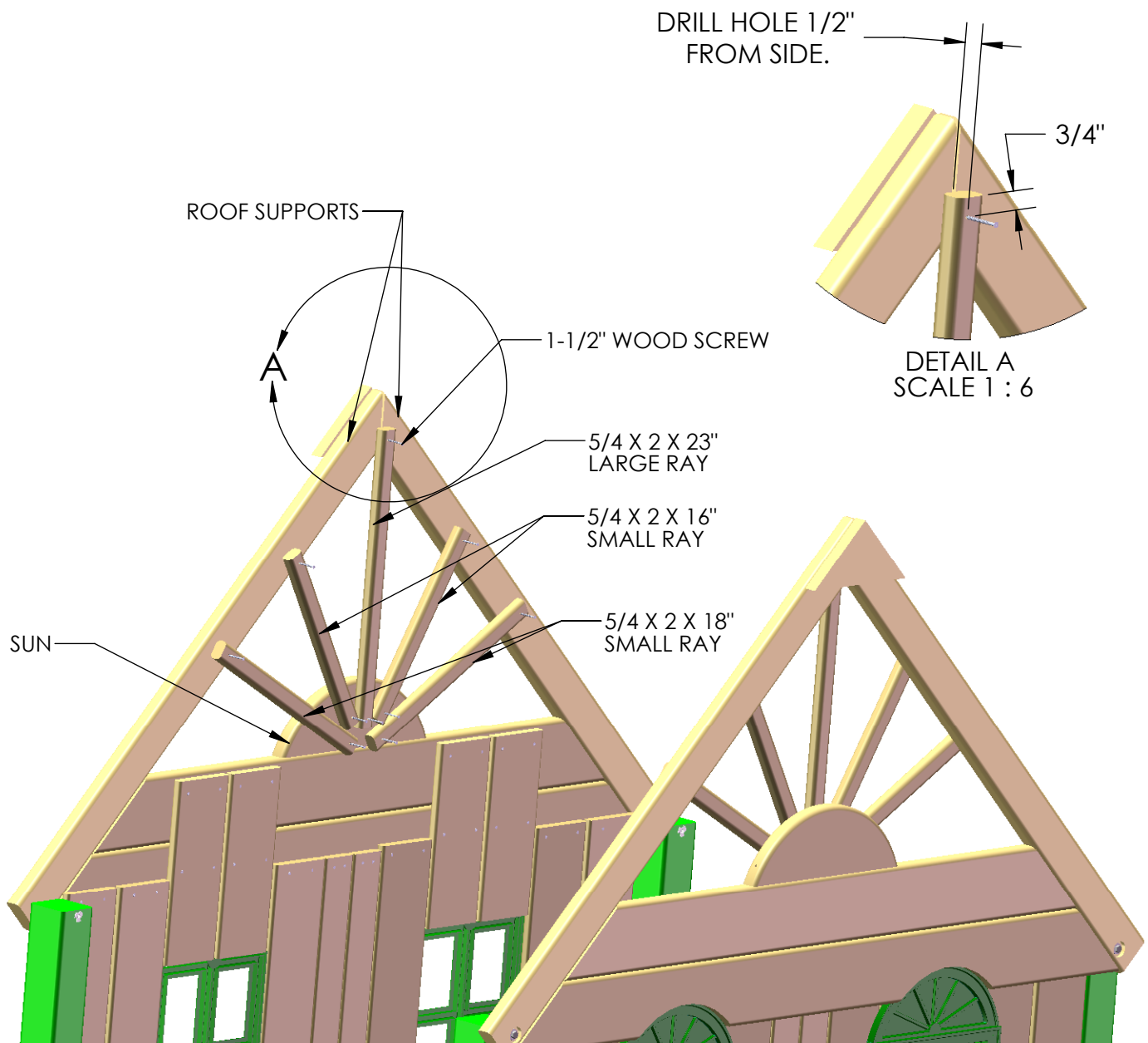

STEP 45: SUNBURST

1: INSTALL SUNBURST SCREENS AS SHOWN BELOW, SO THAT IT IS FLUSH TO THE ROOF SUPPORTS. FASTEN EACH SCREEN WITH SIX 1-1/4" PAN HEAD SCREWS INTO THE GROMMETS IN THE SCREEN.

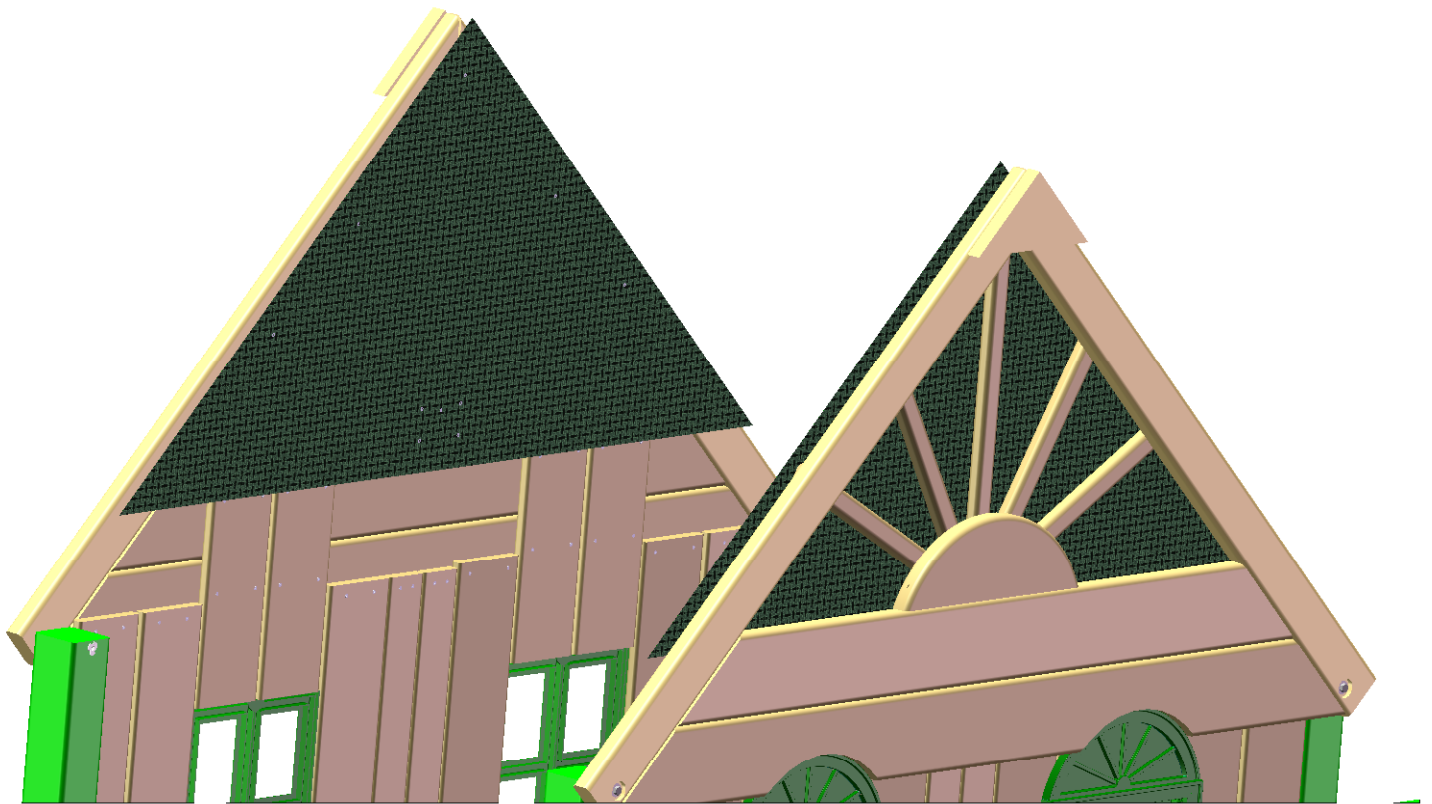

STEP 46: PANEL SUPPORT

1: MEASURE 17-3/4" FROM THE BOTTOM OF THE SANDBOX BOARD ON THE FRONT FACE OF THE FORT. MARK THESE POSITIONS ON THE OUTSIDE OF THE CORNER POSTS. LINE UP THE TOP OF THE 2 X 4 X 78" PANEL SUPPORT WITH THE MARKS. ATTACH THE 2 X 4 X 78" PANEL SUPPORT WITH "OFFSET HOLES UP" TO THE CORNER POSTS WITH 3/8" X 3-1/2" LAG SCREWS AND 3/8" WASHERS.

NOTE: ROCK WALL OMITTED FOR CLARITY.

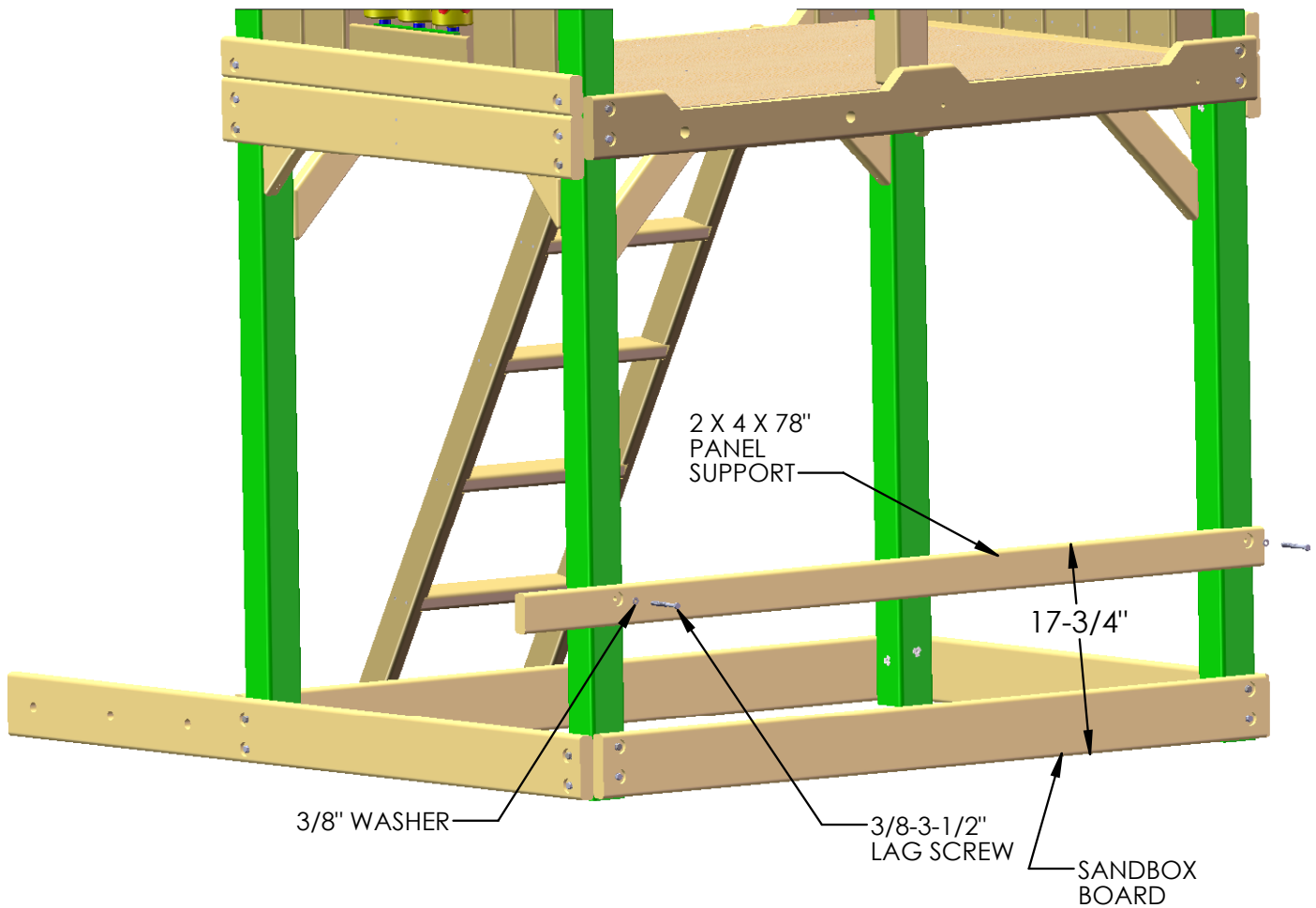

STEP 47: SAFETY BOARD

1: MEASURE 17-3/4" FROM BOTTOM OF THE SANDBOX BOARD ON THE RIGHT SIDE OF THE FORT. MARK THESE POSITIONS ON THE OUTSIDE OF THE CORNER POSTS.

2: ALIGN THE TOP OF THE SAFETY PANEL BOARD WITH THE MARKS. ATTACH THE 2 X 4 X 47-1/2" SAFETY BOARD WITH "OFFSET HOLES DOWN" TO THE CORNER POSTS WITH 3/8" X 3-1/2" LAG SCREWS AND 3/8" WASHERS.

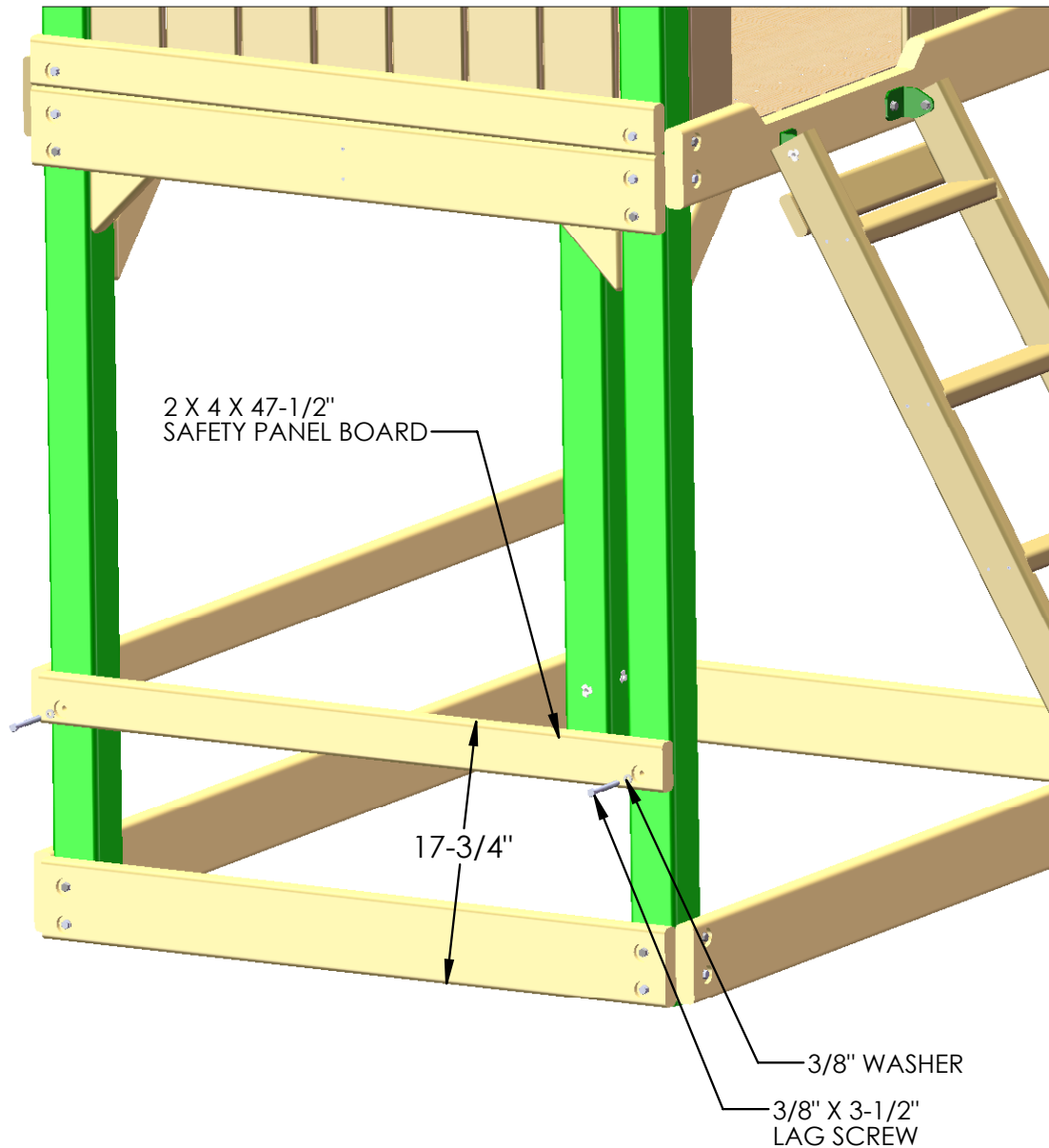

STEP 48: PICNIC TABLE

1: PLACE EACH OF THE 2 X 4 X 30" PICNIC TABLE VERTICAL SUPPORTS 15" OVER FROM THE CORNER POSTS. (SEE REAR VIEW)

2: MAKE SURE THE PICNIC TABLE VERTICAL SUPPORTS ARE SQUARE TO THE SANDBOX BOARDS. ATTACH THEM TO THE SANDBOX BOARDS FROM THE INSIDE USING TWO 2-1/2" WOOD SCREWS. ATTACH THE PICNIC TABLE VERTICAL SUPPORT (ON FRONT OF THE PLAYSET) TO THE 2 X 4 X 78" PANEL BOARD USING THREE 2-1/2" SCREWS.

3: NEXT FIND THE 2 X 4 X 31" BENCH SUPPORT BOARD.

4: MEASURE 17-3/4" FROM THE BOTTOM OF THE REAR SANDBOX BOARD AND MAKE A MARK ON THE REAR CORNER POST AND THE REAR PICNIC TABLE VERTICAL SUPPORT. ALIGN THE TOP OF THE BENCH SUPPORT BOARD WITH THE MARKS. LEAVE 8" OF THE BENCH SUPPORT PROTRUDING PAST THE CORNER POST.

5: USE SIX 2-1/2" WOOD SCREWS TO ATTACH THE BENCH SUPPORT BOARD TO THE CORNER POST AND THE PICNIC TABLE VERTICAL SUPPORT.

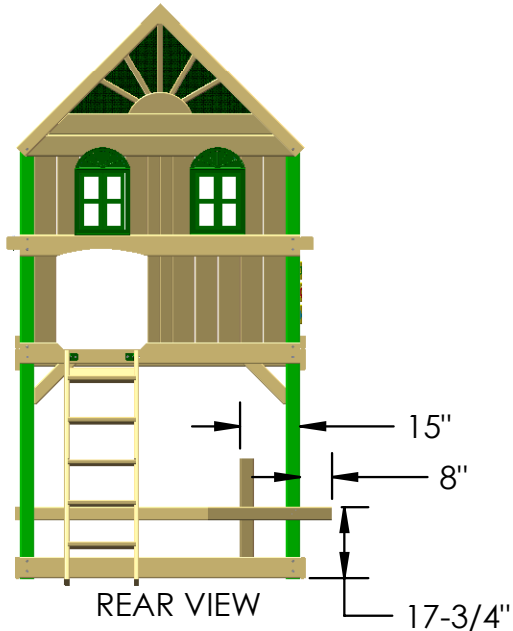

NOTE: ROCK WALL REMOVED FOR CLARITY.

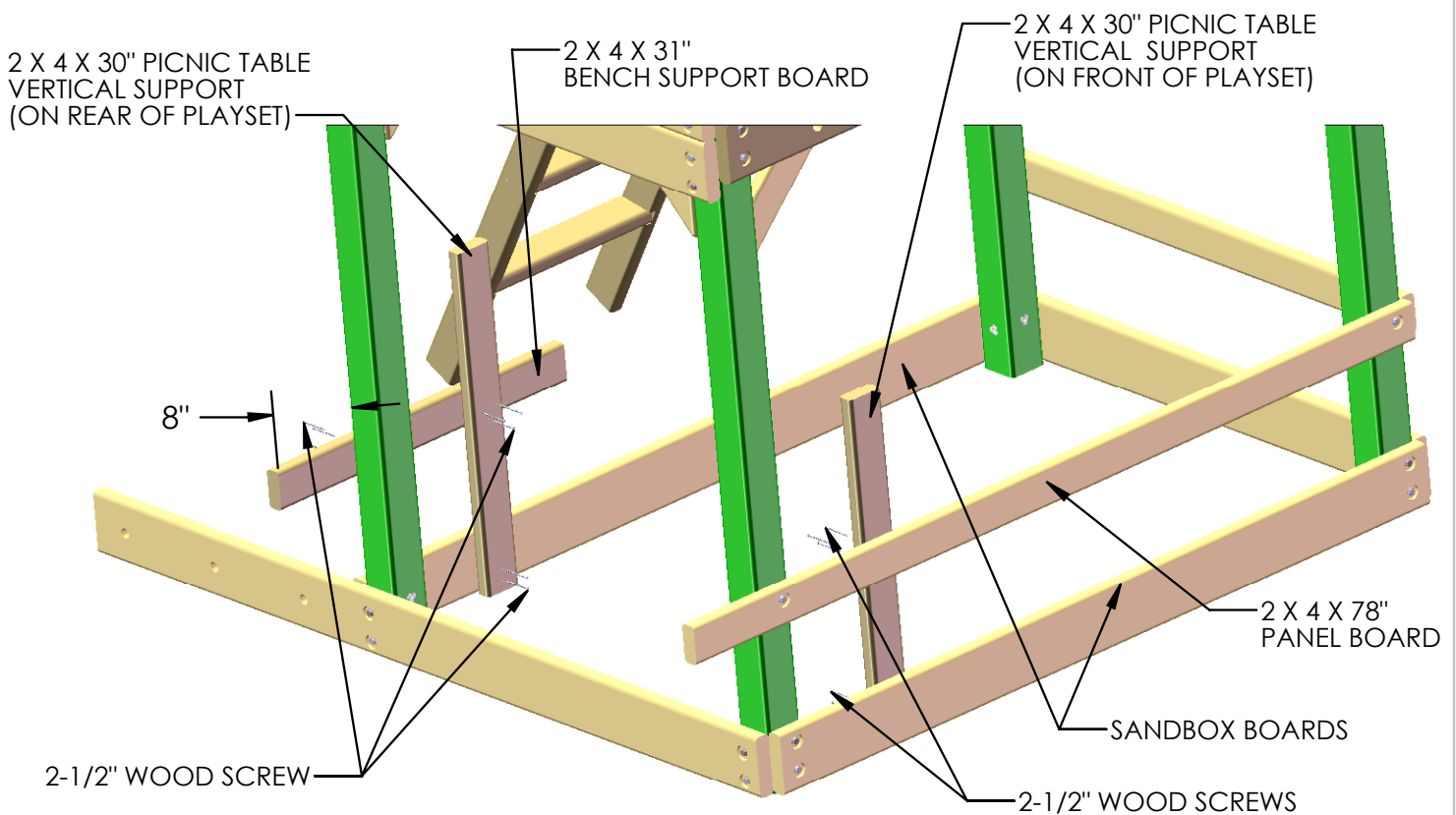

STEP 49: PICNIC TABLE

1: FIND TWO 2 X 4 X 15" PICNIC TABLE SUPPORTS.

2: ATTACH EACH PICNIC TABLE SUPPORT TO THE TOP OF THE PICNIC TABLE VERTICAL SUPPORT AND TO THE CORNER POSTS.

3: ATTACH EACH PICNIC TABLE SUPPORT TO THE PICNIC TABLE VERTICAL SUPPORT AND THE CORNER POST USING SIX 2-1/2" WOOD SCREWS.

[NOTE: ROCK WALL REMOVED FOR CLARITY.]

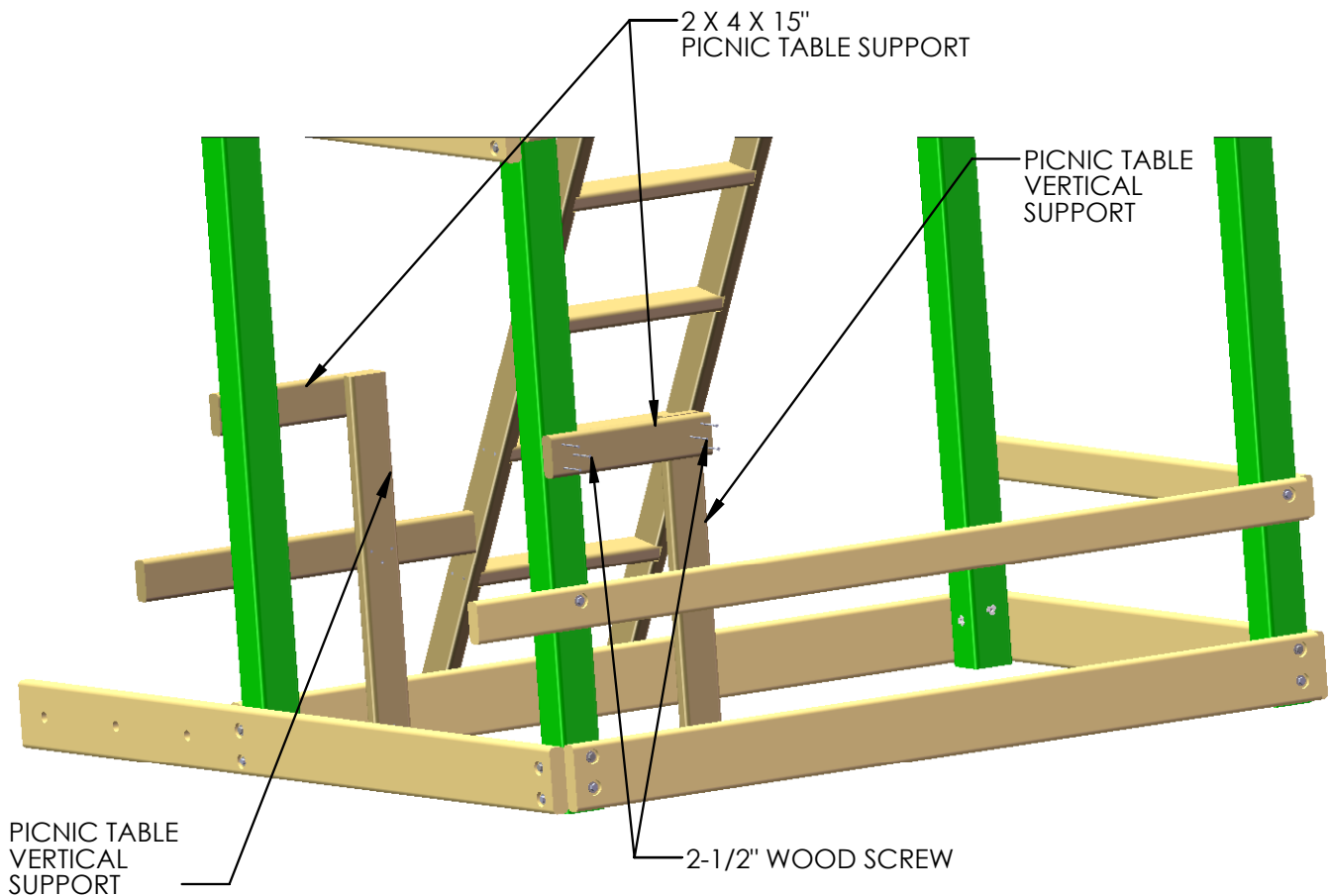

STEP 50: PICNIC TABLE

1: FIND SEVEN 2 X 4 X 51" PICNIC TABLE SEATS AND TOP BOARDS.

2: ATTACH EACH BOARD WITH FOUR 2-1/2" WOOD SCREWS AS SHOWN BELOW TO CREATE THE PICNIC TABLE SEATS AND TOP.

NOTE: LADDER AND ROCK WALL REMOVED FOR CLARITY.

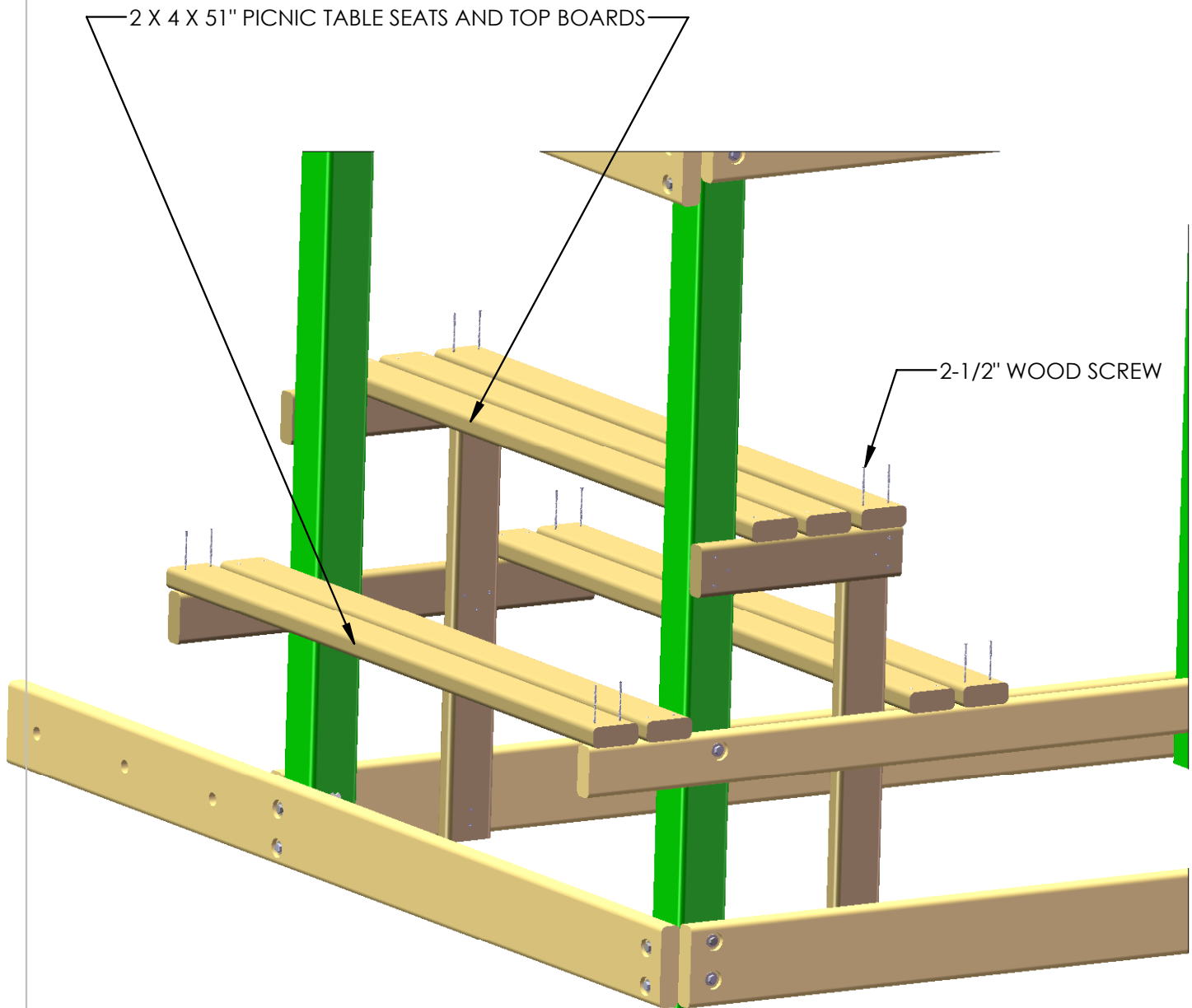

STEP 51: BOTTOM PANEL SLATS

- 1: FIND FIFTEEN 1 X 6 X 17" PANEL SLATS.
- 2: PRE-DRILL SLATS WITH TWO EQUALLY SPACED HOLES 1" FROM EACH END WITH A 1/8" DRILL BIT.
- 3: ATTACH PANEL SLATS ALONG THE SAFETY BOARD AND PANEL BOARD EQUALLY SPACED.
- 4: ATTACH EACH PANEL SLAT USING FOUR 1-1/2" WOOD SCREWS.

NOTE: ROCK WALL AND LADDER REMOVED FOR CLARITY.

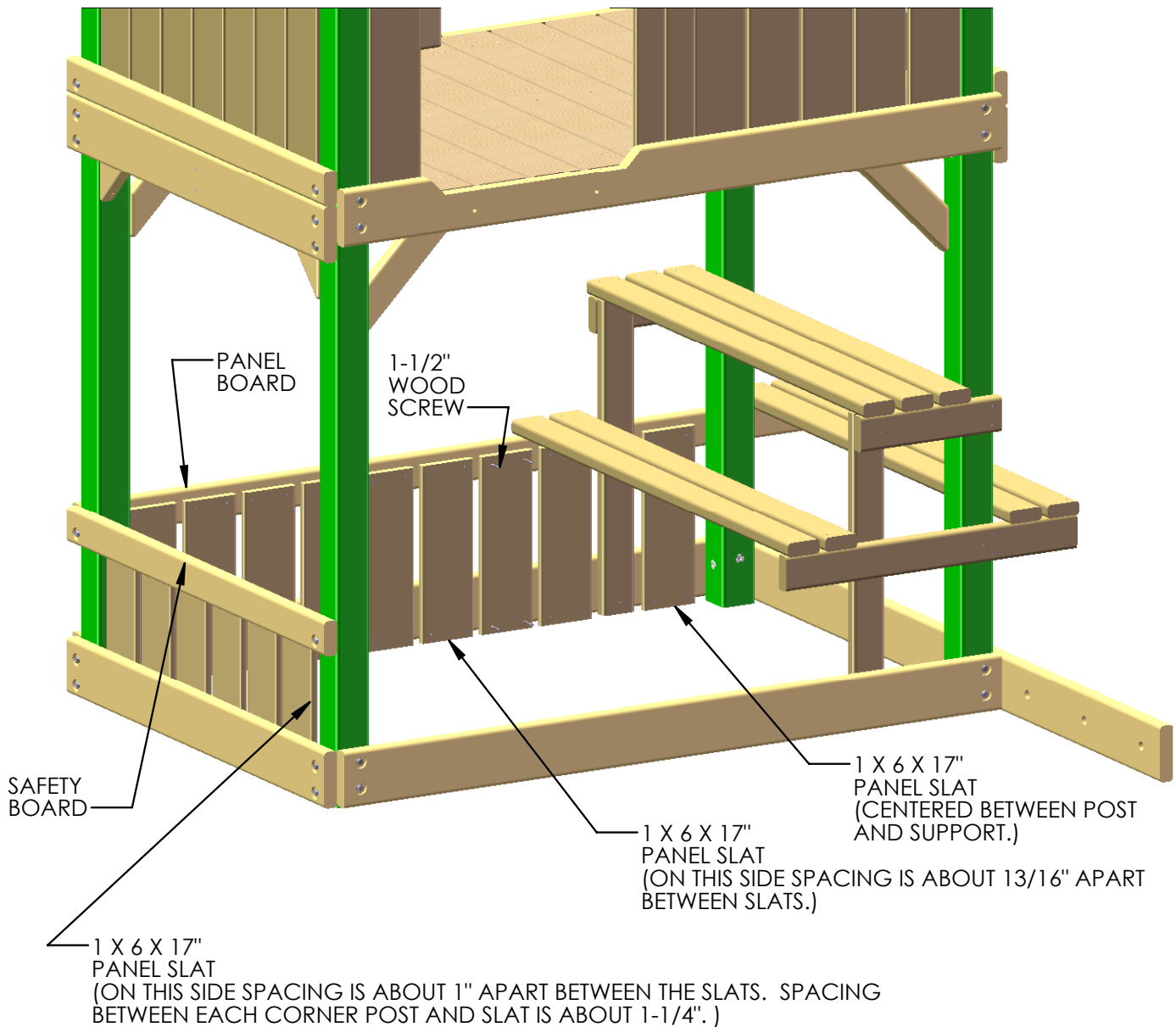

STEP 52: ARCHED SIDE TOP BOARDS

- 1: PLACE THE 2 X 6 X 47-1/2" ARCHED SIDE TOP BOARD UP AGAINST THE TOP OF THE CORNER POSTS ON THE SIDE OF THE FORT.
- 2: ATTACH THE ARCHED SIDE TOP BOARD WITH 3/8" X 3-1/2" LAG SCREWS AND 3/8" WASHERS.
- 3: ATTACH ANOTHER ARCHED SIDE TOP BOARD ON THE OPPOSITE SIDE OF FORT.

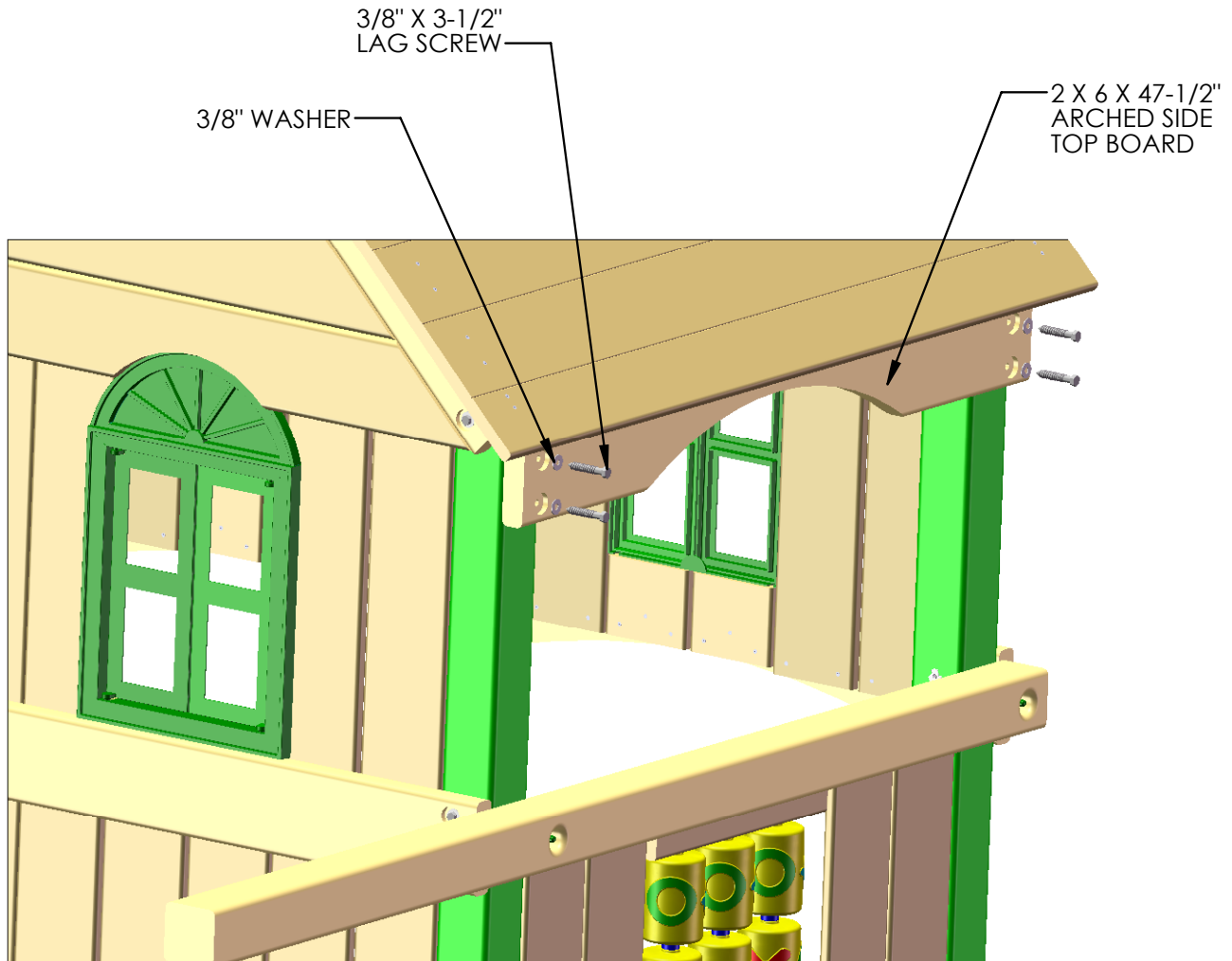

STEP53: CHIMNEY/DORMER

1: USE THE INSTRUCTIONS PROVIDED TO ASSEMBLE AND INSTALL THE CHIMNEY AND DORMERS.

TIP: WHEN INSTALLING THE ROOF BOARDS ONLY INSTALL A FEW ROOF BOARDS THEN ASSEMBLE AND INSTALL THE CHIMNEY. AFTERWARDS INSTALL MORE ROOF BOARDS THEN ASSEMBLE AND INSTALL THE DORMER. FINALLY INSTALL THE REMAINING ROOF BOARDS AND ROOF FINISHER.

ON THE OTHER SIDE OF THE ROOF THERE IS ONLY A DORMER. FOR THAT SIDE INSTALL SOME ROOF BOARDS FIRST. THEN ASSEMBLE AND INSTALL THE DORMER. FINALLY INSTALL THE REMAINING ROOF BOARDS AND FINISHER.

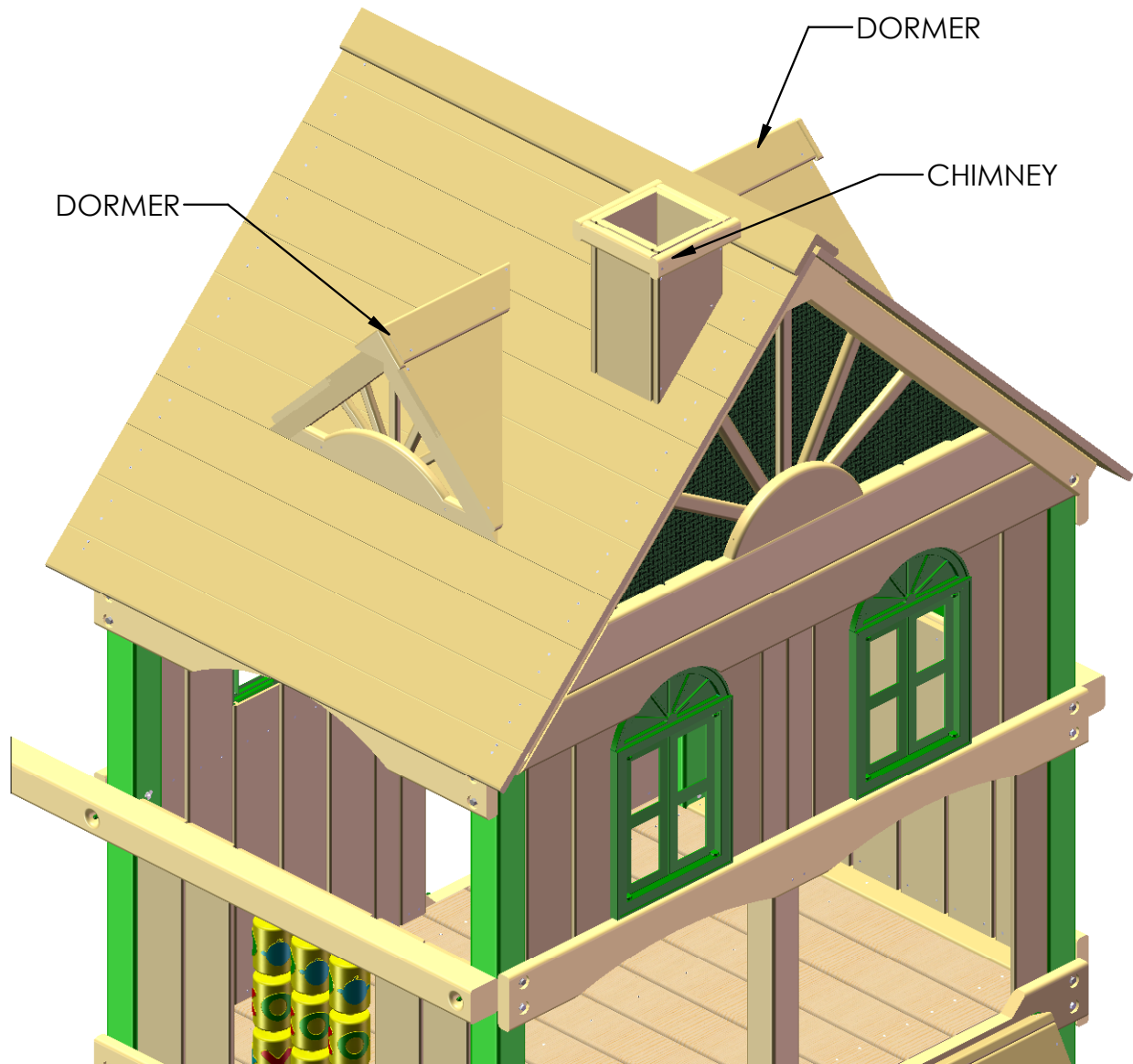

STEP 54: INSTALLING THE CLIMBING ROPE

- 1: DRILL A 7/8" HOLE THROUGH THE FRONT TOP PANEL BOARD (ABOVE THE ROCK WALL) FOR THE CLIMBING ROPE.
- 2: TIE A KNOT AT ONE END OF THE 10' ROPE AND THREAD IT THROUGH THE HOLE IN THE FRONT TOP PANEL BOARD.
- 3: YOU CAN TIE A FEW (NO MORE THAN THREE) KNOTS IN THE ROPE TO AID IN CLIMBING APPROXIMATELY 18" APART BEFORE TYING THE KNOT BEHIND THE BOTTOM ROCK WALL BOARD.

4: THE UNTIED END WILL GO THROUGH THE HOLE OF THE BOTTOM ROCK WALL BOARD. TIE A SECURE KNOT AT THE END MAKING SURE THAT THE ROPE IS TIGHT AND WILL NOT WRAP AROUND YOUR HAND.

HINT: TO REDUCE THE AMOUNT OF SLACK IN THE ROPE, LIFT THE ROCK WALL ASSEMBLY SLIGHTLY WHEN TYING THE KNOT IN THE BOTTOM ROCK WALL BOARD. WHEN YOU LOWER THE ASSEMBLY, THE ROPE WILL TIGHTEN.

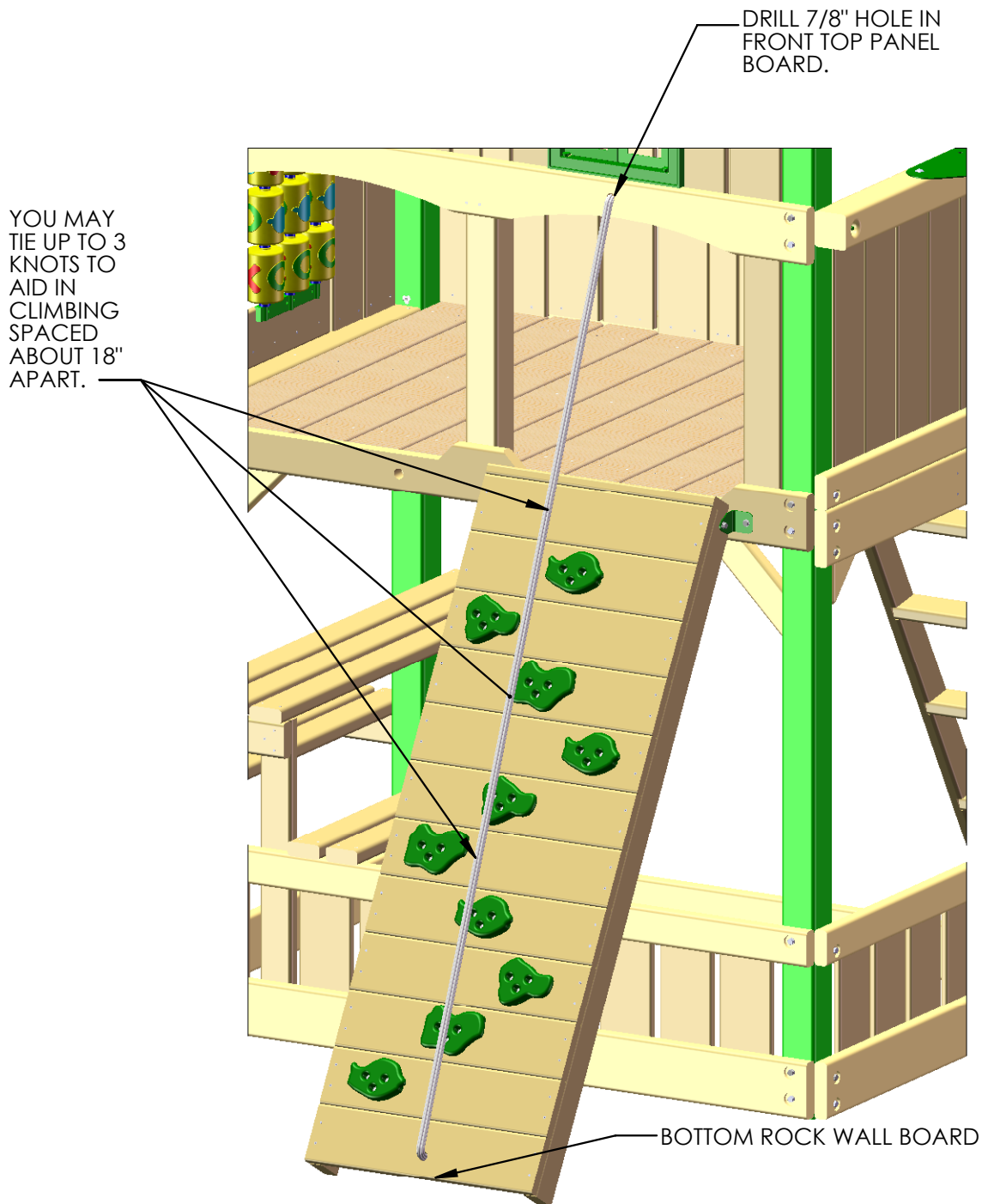

STEP 55: PLASTIC FLAGS

1: FIND THE PLASTIC FLAG KIT.

2: ATTACH THE FLAGS TO THE FRONT CORNER POSTS AS SHOWN BELOW.

3: ATTACH EACH FLAG TO THE CORNER POST THROUGH THE PRE-DRILLED HOLES USING 1/2" PHILLIPS HEAD WOOD SCREWS PROVIDED WITH THE FLAG KIT.

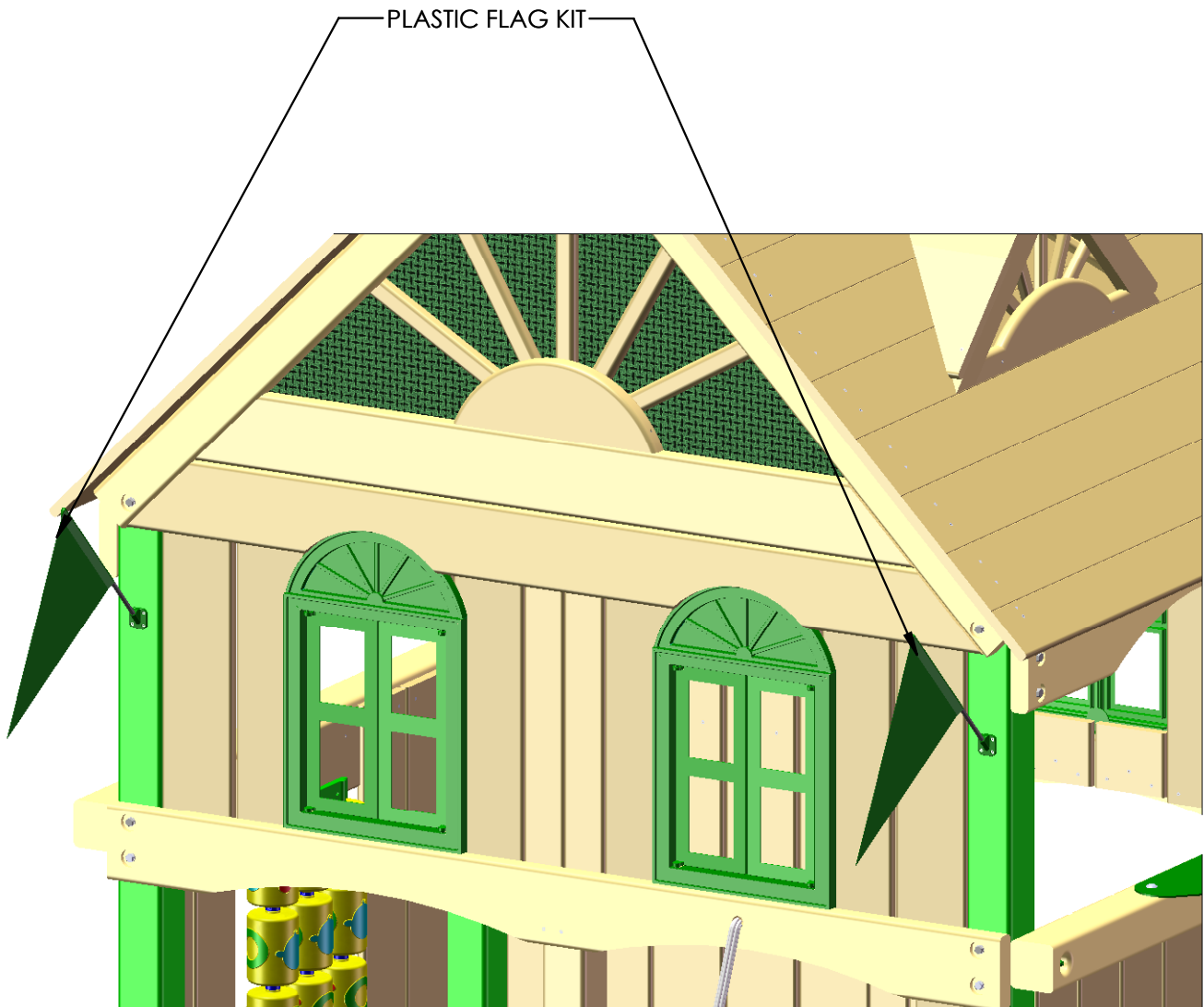

STEP 56: MOUNTING TELESCOPE

1: PLACE THE TELESCOPE ASSEMBLY ON THE ROPE LADDER SUPPORT ABOVE THE TIC TAC TOE PANEL. USING THE 1-1/4" WOOD SCREWS PROVIDED IN THE TELESCOPE BAG, FASTEN ONE OF THE ROUND TELESCOPE BRACKETS TO THE ROPE LADDER SUPPORT.

2: PLACE THE TELESCOPE STAND INTO THE SLOT OF THE TELESCOPE BRACKET.

3: PLACE THE REMAINING ROUND TELESCOPE BRACKET ACROSS FROM THE FIRST BRACKET. FASTEN THE ROUND TELESCOPE BRACKET WITH 1-1/4" WOOD SCREWS TO THE ROPE LADDER SUPPORT.

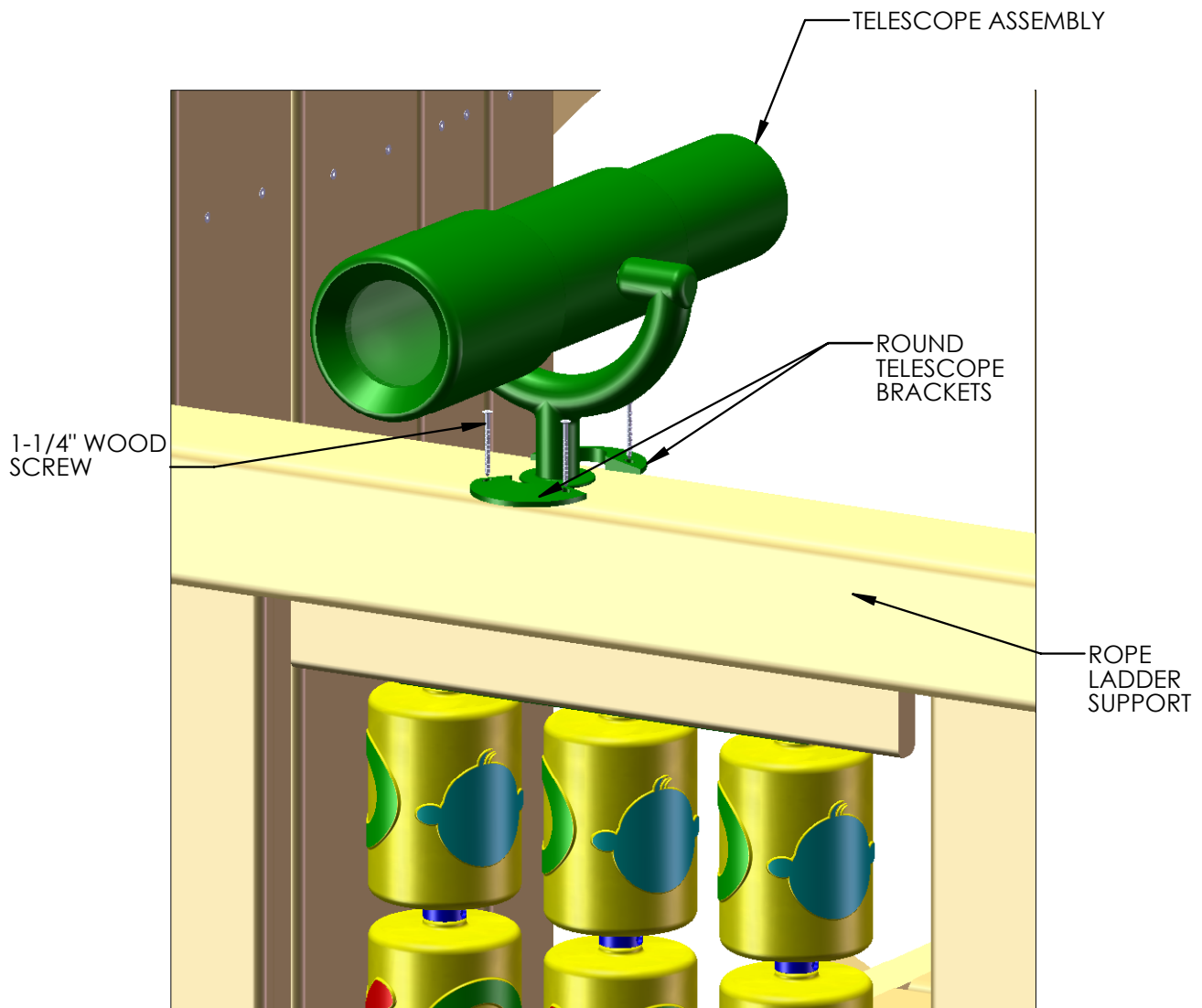

STEP 57: STEERING WHEEL

1: PLACE THE STEERING WHEEL INSERT INSIDE THE STEERING WHEEL.

2: USE THE HARDWARE INCLUDED WITH THE STEERING WHEEL TO MOUNT THE STEERING WHEEL TO THE SWING BEAM. DO NOT OVER-TIGHTEN THE LAG SCREW INTO THE STEERING WHEEL, OR IT WILL NOT TURN.

3: PLACE THE STEERING WHEEL CAP OVER THE CENTER OF THE STEERING WHEEL.

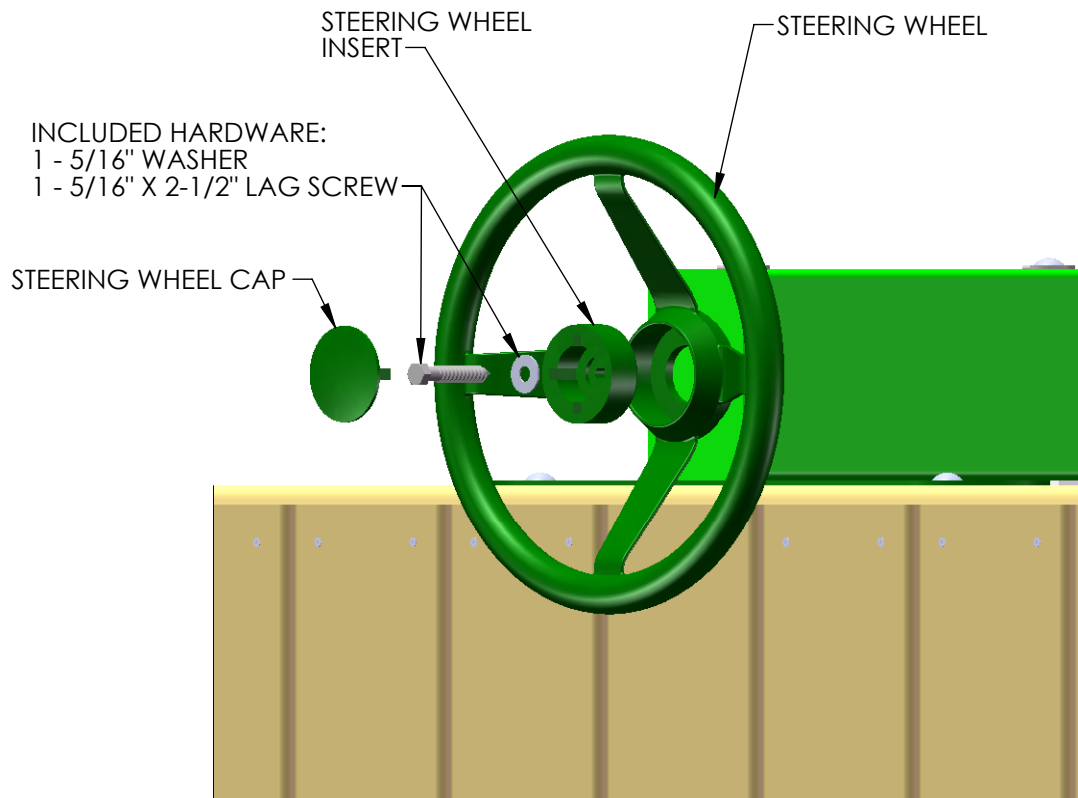

STEP 58: ATTACHING THE SAFETY HANDLES

1: LOCATE TWO SAFETY HANDLES PROVIDED WITH YOUR PLAYSET.

2: LOCATE THE HARDWARE PROVIDED IN THE BAG WITH THE HANDLES.

****DO NOT USE THE SCREWS PROVIDED IN THE BAG WITH THE HANDLES****

3: LOCATE FOUR #14 X 1" LONG PAN HEAD SCREWS IN YOUR MAIN HARDWARE PACKAGE. USE THE 1/4" FLAT WASHERS PROVIDED IN THE BAG WITH THE HANDLES.

4: PLACE THE HANDLES 1" AWAY FROM THE EDGE OF EACH PANEL SLAT ABOVE THE LADDER AT THE REAR OF THE PLAY SET. ADJUST THE HANDLES UP OR DOWN TO SUIT THE NEEDS OF YOUR CHILD.

5: ATTACH EACH HANDLE TO THE PANEL SLATS USING TWO #14 X 1" LONG PAN HEAD SCREWS AND TWO 1/4" FLAT WASHERS.

****DO NOT USE THE SCREWS PROVIDED IN THE BAG WITH THE SAFETY HANDLES.****

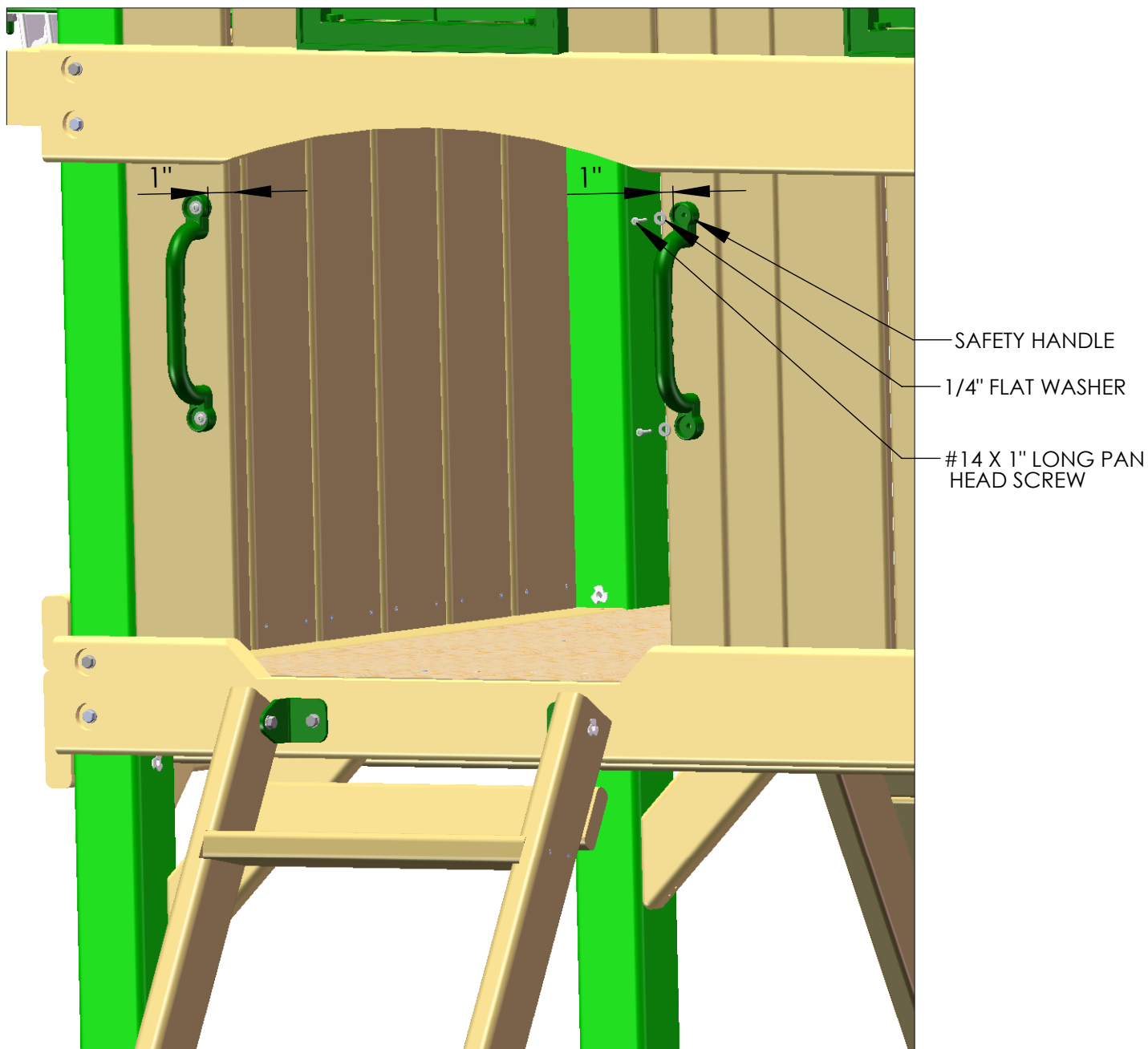

STEP 59: HANGING THE SWINGS

- 1: START BY ATTACHING ONE SPRING CLIP TO EACH IRON DUCTILE ON THE SWING BEAM.
- 2: ATTACH ONE CHAIN PER ACCESSORY TO EACH SPRING CLIP.
- 3: ADJUST HEIGHT AS NEEDED.

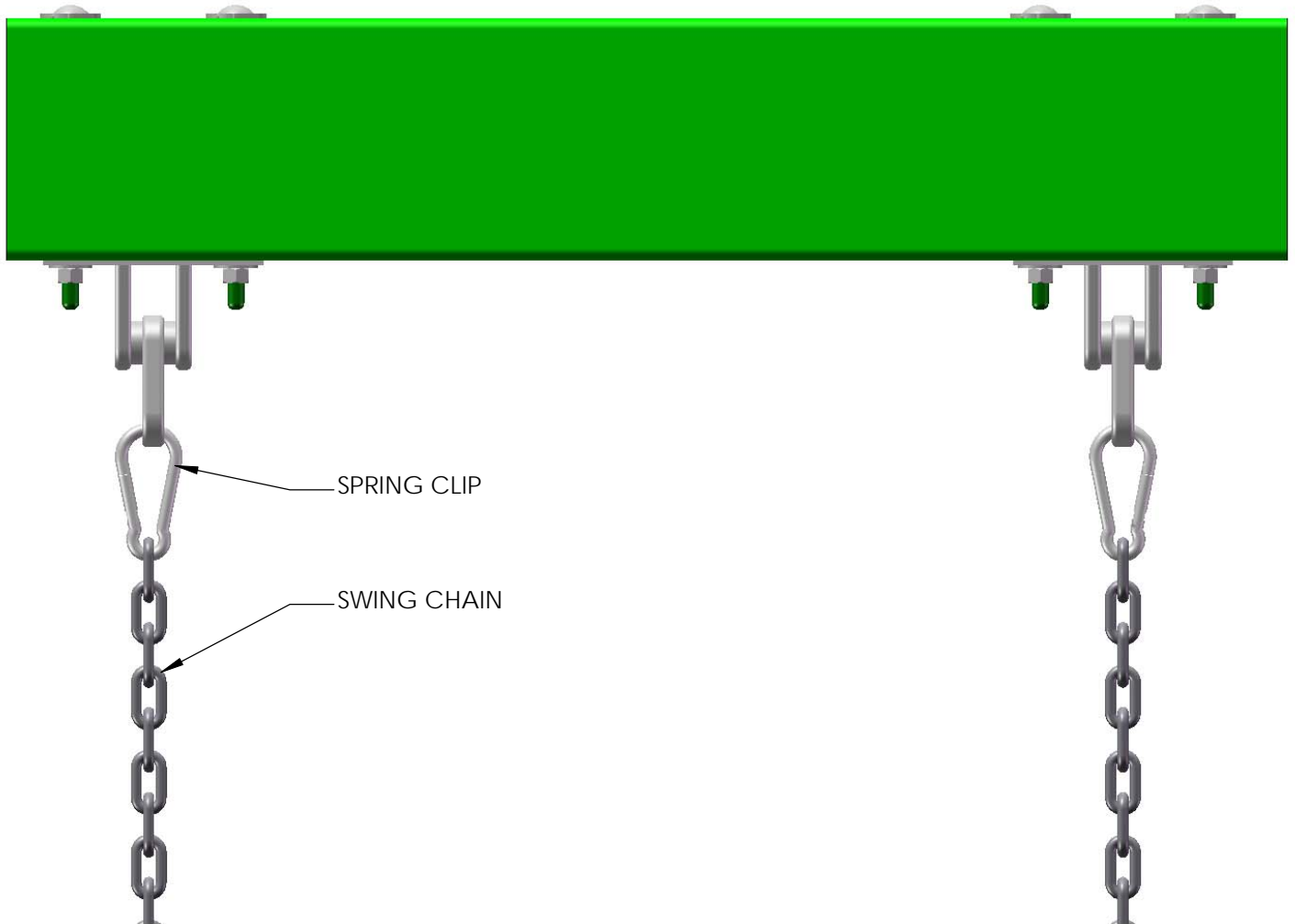

STEP 60: ROPE LADDER ASSEMBLY

1: DRILL THREE 1/8" PILOT HOLES 2" DEEP INTO THE BOTTOM OF THE ROPE LADDER SUPPORT. (SEE DIMENSIONS BELOW)

2: SCREW THE EYEBOLT LAG SCREWS INTO THE HOLES AT THE BOTTOM OF THE ROPE LADDER SUPPORT AND TIGHTEN.

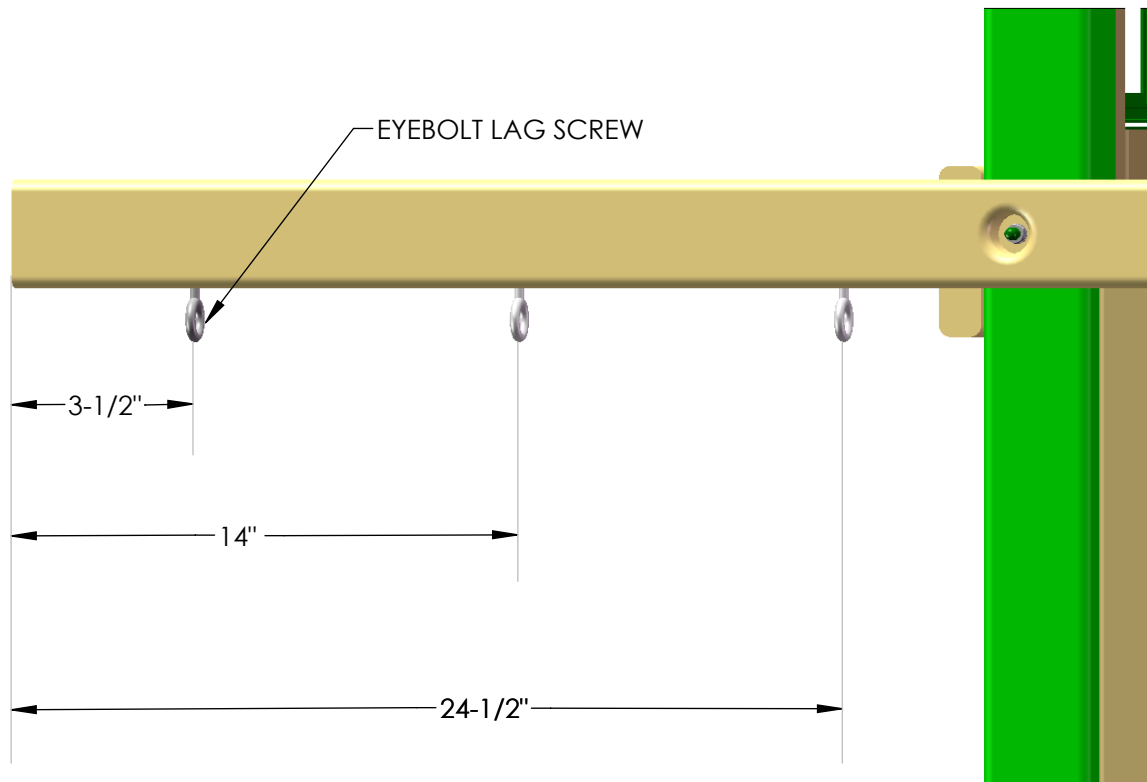
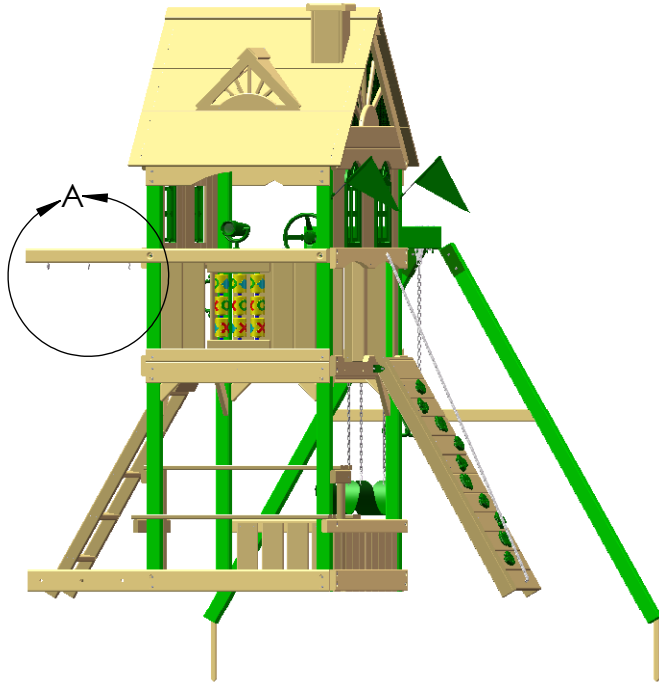

DETAIL A
SCALE 1 : 6

STEP 61: ROPE LADDER ASSEMBLY

1: PLACE THE HOOKS ON THE END OF THE ROPE LADDER ASSEMBLY THROUGH THE EYE OF THE EYEBOLT LAGS.

2: THREAD THE BOTTOM ROPE ENDS OF THE ROPE LADDER THROUGH THE HOLES IN THE ROPE LADDER RUNNER AND TIE A SECURE KNOT IN THE END OF EACH ROPE.

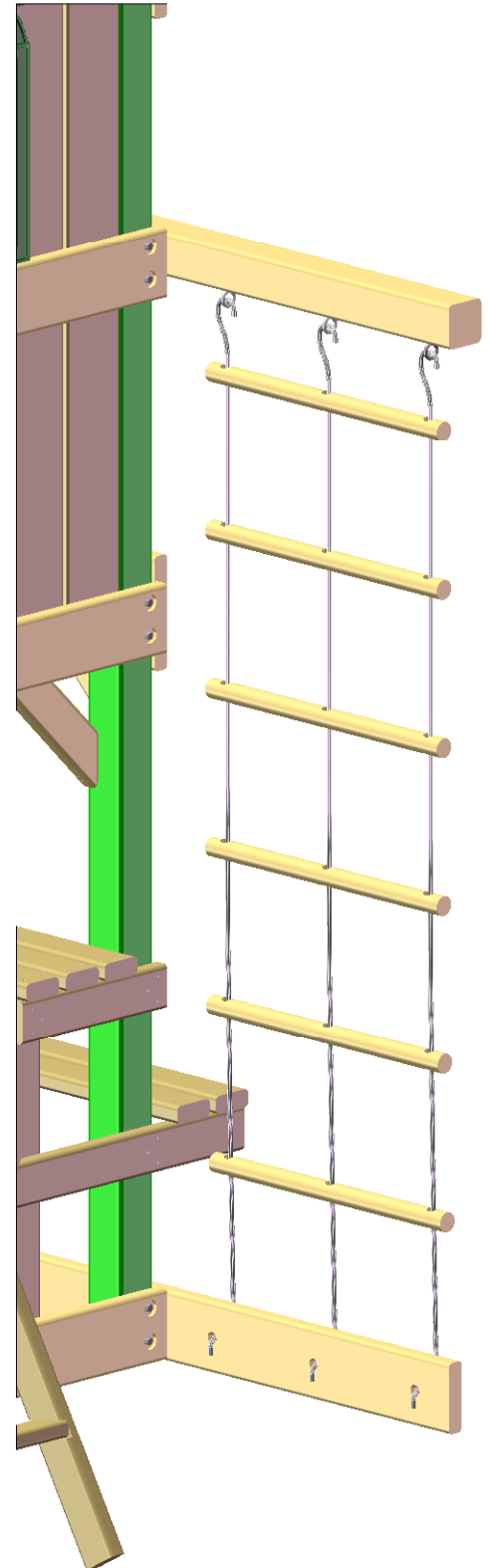

PART II

CLATTER BRIDGE WITH TARP FOR WOODBRIDGE PLAY SET

5/16" X 3-1/2"
HEX LAG
SCREW
QTY: 34

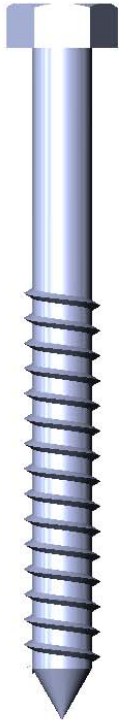

3/8 X 5"
HEX LAG SCREW
QTY: 4

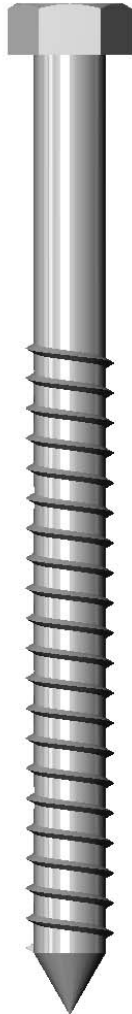

NOTE: THIS SHEET IS A COMBINATION OF
11-1920 AND 11-0026 HARDWARE.

CHAIN
QUICK LINK
QTY: 2

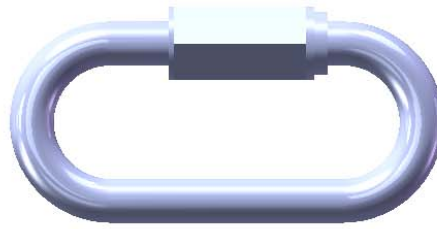

#14 X 1-1/4"
PAN HEAD SCREW
QTY: 7



#8 X 2"
WOOD SCREW
QTY: 90



#8 X 2-1/2"
WOOD SCREW
QTY: 20



#2 SQUARE
DRIVE BIT
QTY: 1



5/16 X 1-3/4"
HEX BOLT
QTY: 30



5/16 X 3-1/2"
HEX BOLT
QTY: 4

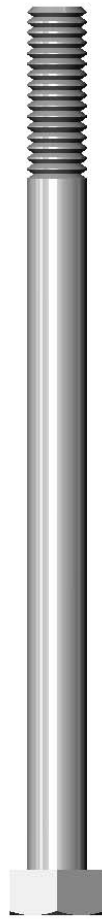

5/16" x 4-1/2"
HEX BOLT
QTY: 24



3/8" WASHER
QTY: 4



5/16" WASHER
QTY: 144



1/4" WASHER
QTY: 7



5/16" TEE NUT
QTY: 56

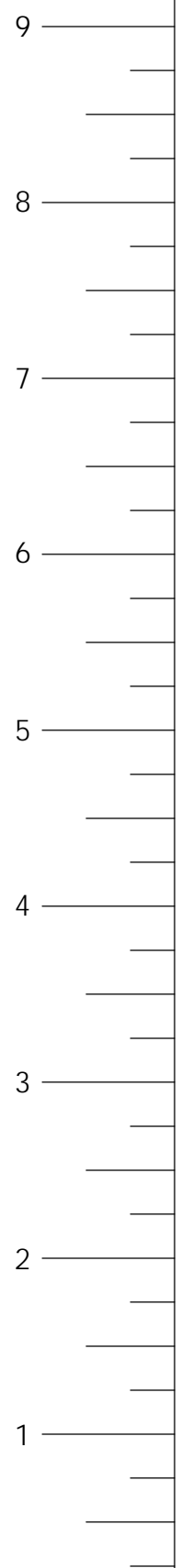

USE THE RULER TO THE RIGHT TO MEASURE YOUR BOLTS AND SCREWS. PICTURE VIEWS SHOWN
ABOVE ARE 1:1 SCALE AND CAN BE USED TO MATCH BOLT AND SCREW SIZES.

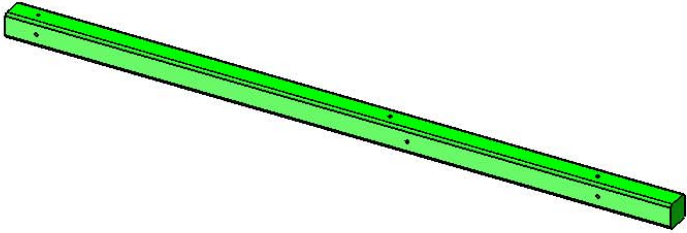
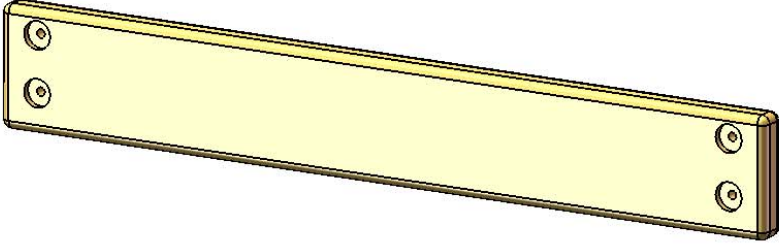
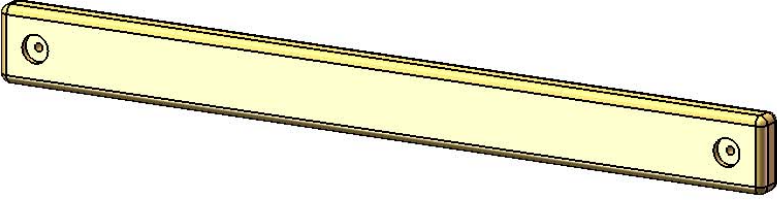
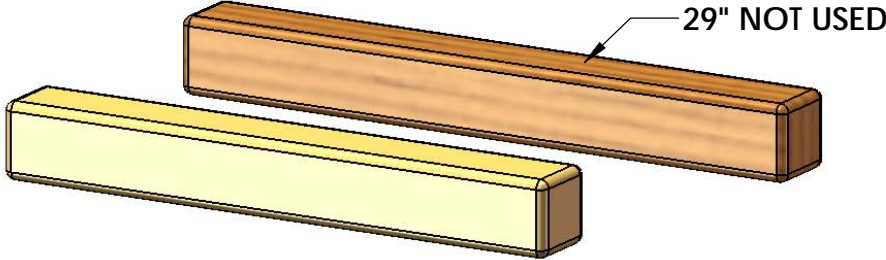
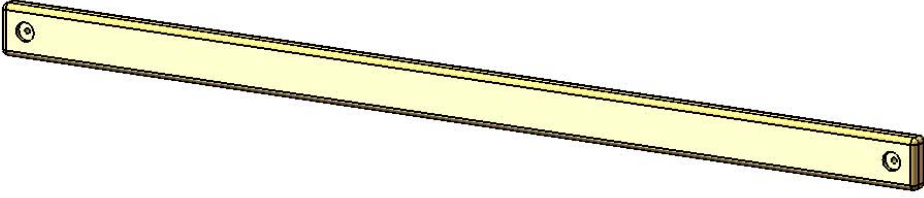
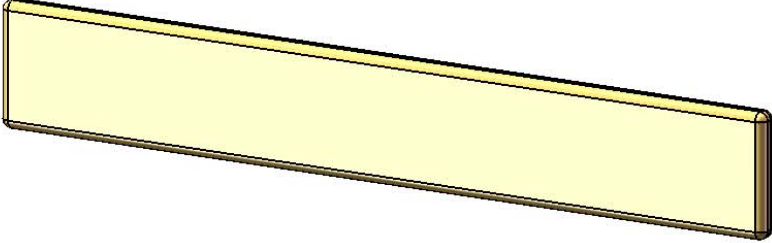
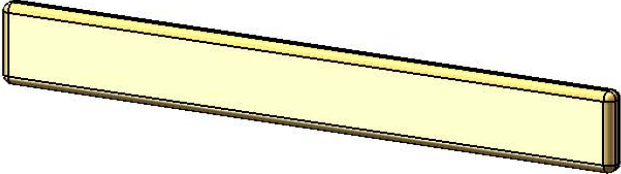
	PICTURE	DESCRIPTION	QTY.
<p>NOTE: THIS LIST IS A COMBINATION OF THE 106 AND 802 WOOD KITS.</p>		<p>4 X 4 X 96" CORNER POST</p>	<p>4</p>
		<p>2 X 6 X 36-3/4" SANDBOX BOARDS</p>	<p>6</p>
		<p>2 X 4 X 36-3/4" TOP PANEL/DECK SUPPORT/BOTTOM PANEL BOARD</p>	<p>8</p>
		<p>4 X 4 X 29" CENTER POST (NOT USED)</p> <p>4 X 4 X 26" CENTER LAG POST</p>	<p>1</p> <p>1</p>
		<p>2 X 4 X 66" SAFETY RAIL</p>	<p>4</p>
		<p>5/4 X 6 X 36-11/16" DECK BOARD</p>	<p>5</p>
		<p>5/4 X 4 X 29-3/8" DECK SPACER</p>	<p>2</p>

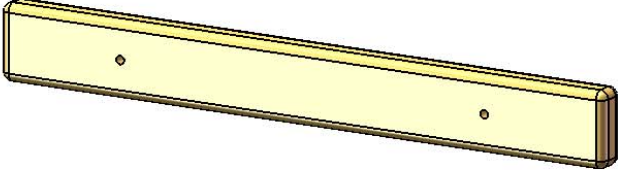
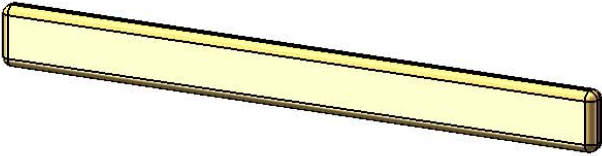
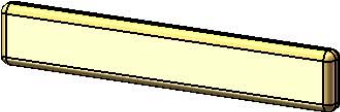
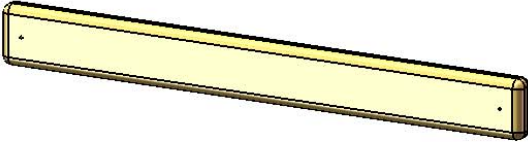
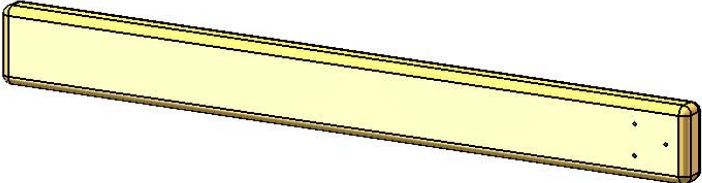
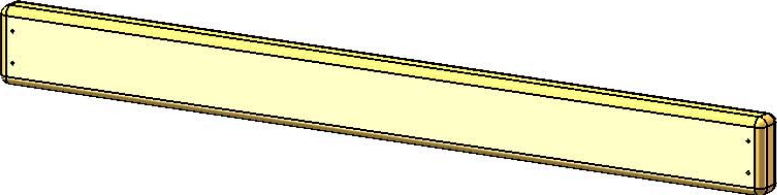
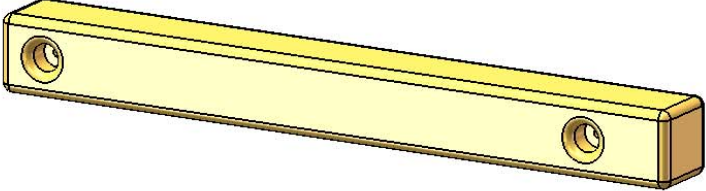
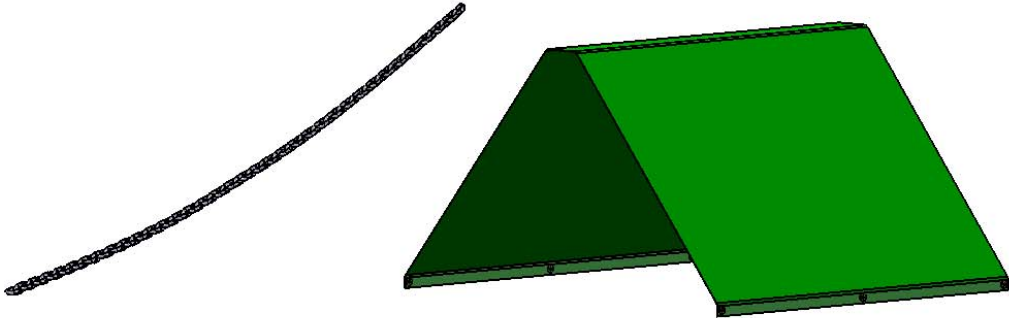
PICTURE	DESCRIPTION	QTY.
	2 X 4 X 29" BRIDGE DECK BOARD	15
	5/4 X 2-5/8" X 28-1/2" PANEL SLAT	10
	5/4 X 2-5/8" X 16" BRIDGE SLAT	20
	5/4 x 2-5/8" x 25" PANEL SLAT LEFT	1
	2 X 4 X 33" VERTICAL TARP SUPPORT	2
	2 X 4 X 36-3/4" TARP BOARD	3
	4 X 4 X 32" RAD RIDE 5 LAG POST	2
	96" CHAIN SECTION 802 TARP 57-1/2" X 34-1/4"	2 1

STEP 1: ATTACHING T-NUTS TO THE CORNER POSTS

- 1: THIS STEP IS CRITICAL TO BUILDING THE FORT PROPERLY. IF ANY MISTAKES ARE MADE HERE, YOU WILL NEED TO DIS-ASSEMBLE AND THEN RE-ASSEMBLE TO MAKE YOUR CORRECTIONS.
- 2: MAKE SURE HOLES ARE FREE OF ANY OBSTRUCTIONS. USE A BOLT TO CLEAN OUT ANY DEBRIS.
- 3: LAY OUT EACH OF THE 4 X 4 X 96" CORNER POSTS IN THE AREA YOU INTEND ON BUILDING THE TOWER OF THE CLATTER BRIDGE.
- 4: USE THE DIAGRAM BELOW TO CORRECTLY IDENTIFY AND ORIENT THE NECESSARY DIRECTION THE POSTS SHOULD FACE. NOTE LETTERS A, B, C AND D ARE FOR REFERENCE ONLY. YOUR POSTS ARE **NOT** LABELED WITH THESE LETTERS.
- 5: USE A HAMMER TO SEAT THE T-NUTS AFTER INSERTING THEM INTO THE HOLES SHOWN IN THE DIAGRAM BELOW.
- 6: THE BARREL OF THE T-NUT SHOULD GO IN THE HOLE FIRST. HAMMER THE T-NUT UNTIL IT IS FLUSH/ALMOST FLUSH TO THE CORNER POSTS.

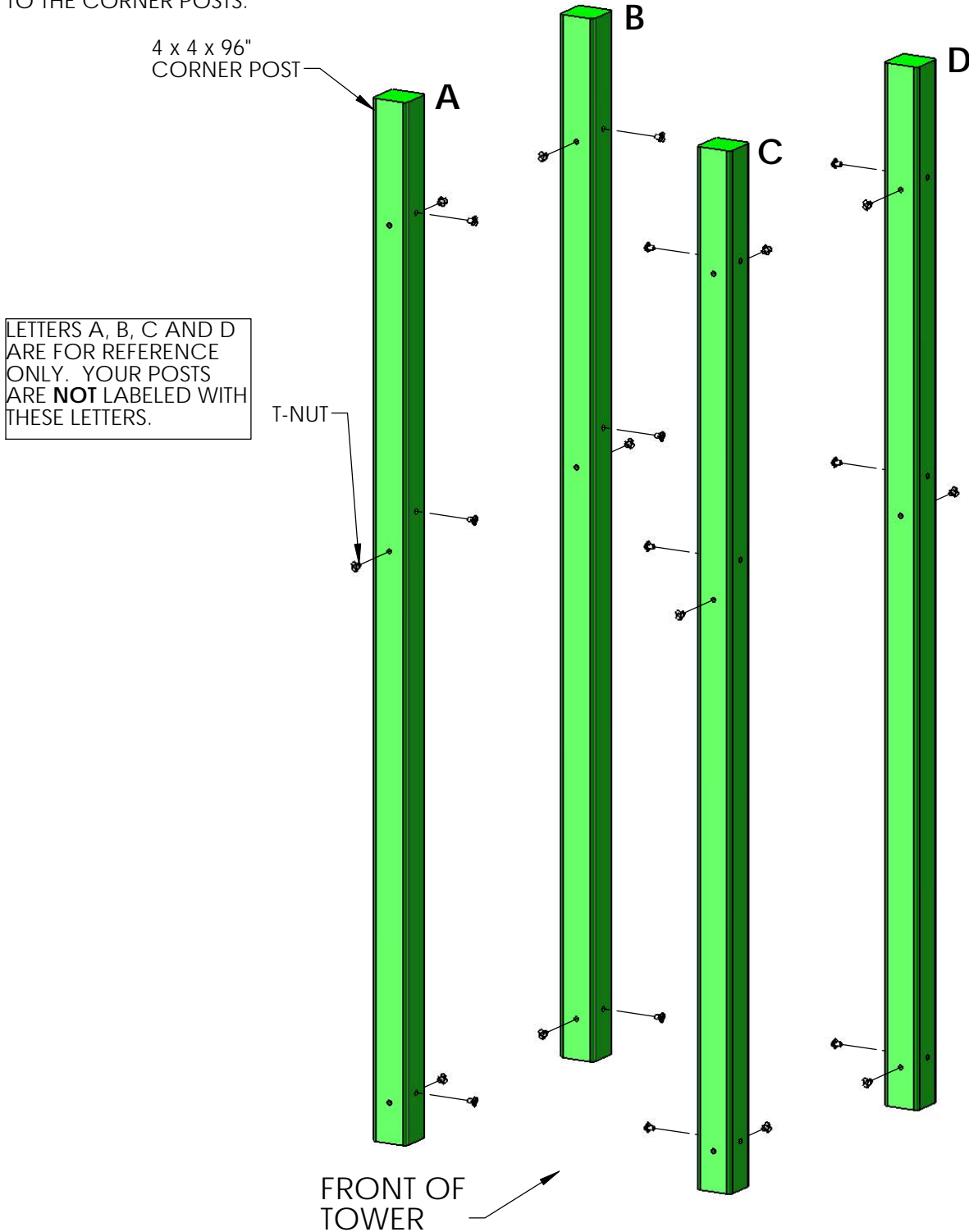

STEP 2: ASSEMBLING THE RIGHT SIDE FRAME

- 1: LAY THE 2 X 6 X 36-3/4" SANDBOX BOARD ON TOP OF THE RIGHT SIDE CORNER POSTS AT THE BOTTOM OF THE CORNER POSTS. THE COUNTERSUNK HOLES IN THE SANDBOX BOARD MUST BE OFFSET UP.
- 2: USE 5/16 X 4-1/2" HEX BOLTS AND 5/16" WASHERS TO ATTACH THE TOP HOLES OF THE SANDBOX BOARD TO THE T-NUTS INSTALLED ON THE CORNER POSTS. THE BOTTOM HOLES WILL BE USED LATER.
- 3: LAY THE 2 X 6 X 36-3/4" BOTTOM PANEL BOARD ON TOP OF THE RIGHT SIDE CORNER POSTS IN THE MIDDLE OF THE CORNER POSTS. THE COUNTERSUNK HOLES IN THE BOTTOM PANEL BOARD MUST BE OFFSET UP.
- 4: USE 5/16 X 4-1/2" HEX BOLTS AND 5/16" WASHERS TO ATTACH THE TOP HOLES OF THE BOTTOM PANEL BOARD TO THE T-NUTS INSTALLED ON THE CORNER POSTS. THE BOTTOM HOLES WILL BE USED LATER.
- 5: LAY THE 2 X 4 X 36-3/4" TOP PANEL BOARD ON TOP OF THE RIGHT SIDE CORNER POSTS.
- 6: USE 5/16 X 4-1/2" HEX BOLTS AND 5/16" WASHERS TO ATTACH THE COUNTERSUNK HOLES OF THE TOP PANEL BOARD TO THE T-NUTS INSTALLED ON THE CORNER POSTS.
- 7: DO NOT INSTALL LAG SCREWS AT THIS TIME.

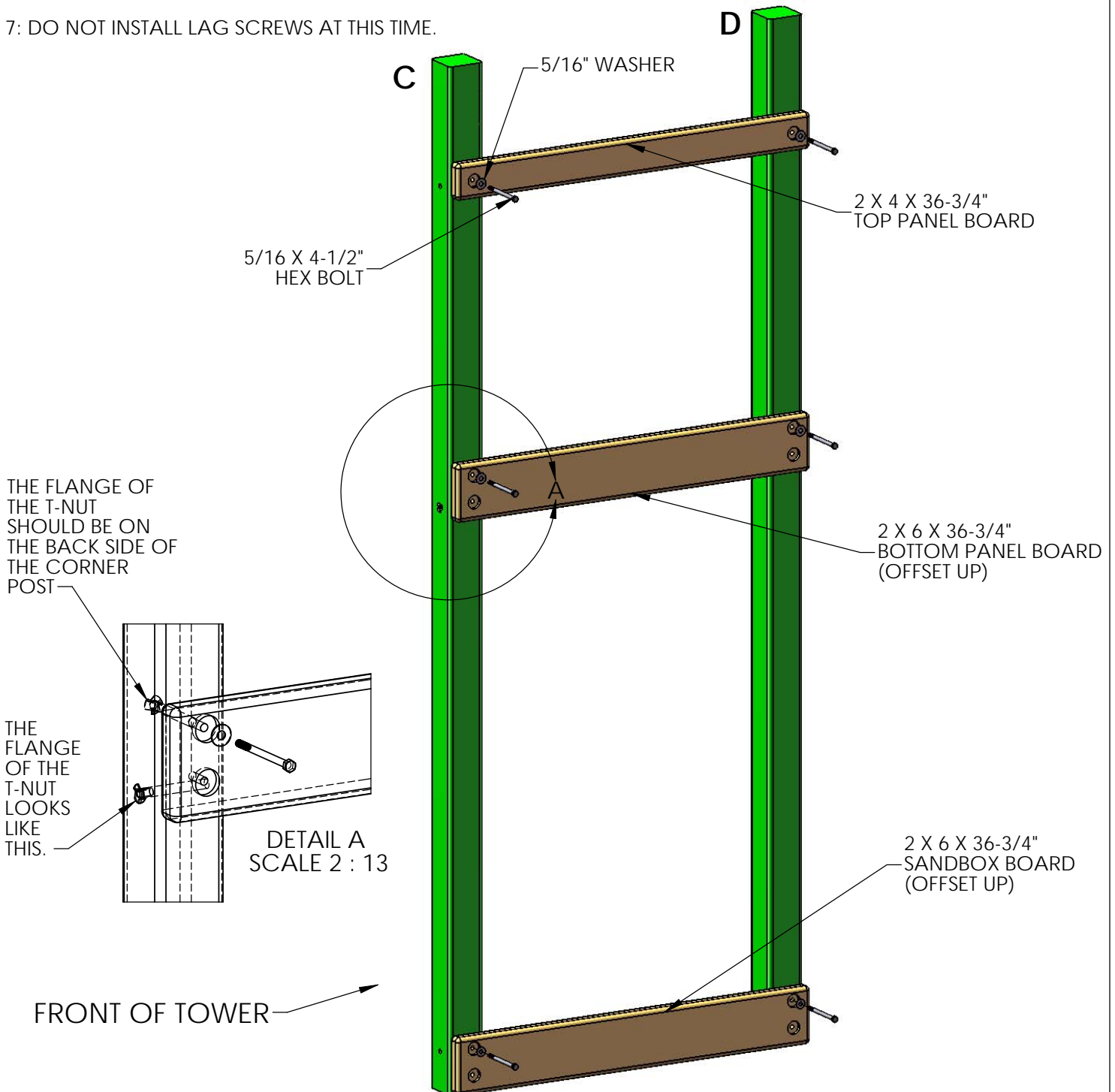

STEP 3: ASSEMBLING THE LEFT SIDE FRAME

1: LAY THE 2 X 6 X 36-3/4" SANDBOX BOARD ON TOP OF THE LEFT SIDE CORNER POSTS AT THE BOTTOM OF THE CORNER POSTS. THE COUNTERSUNK HOLES IN THE SANDBOX BOARD MUST BE OFFSET UP.

2: USE 5/16 X 4-1/2" HEX BOLTS AND 5/16" WASHERS TO ATTACH THE TOP HOLES OF THE SANDBOX BOARD TO THE T-NUTS INSTALLED ON THE CORNER POSTS. THE BOTTOM HOLES WILL BE USED LATER.

3: LAY THE 2 X 6 X 36-3/4" BOTTOM PANEL BOARD ON TOP OF THE LEFT SIDE CORNER POSTS IN THE MIDDLE OF THE CORNER POSTS. THE COUNTERSUNK HOLES IN THE BOTTOM PANEL BOARD MUST BE OFFSET UP.

4: USE 5/16 X 4-1/2" HEX BOLTS AND 5/16" WASHERS TO ATTACH THE TOP HOLES OF THE BOTTOM PANEL BOARD TO THE T-NUTS INSTALLED ON THE CORNER POSTS. THE BOTTOM HOLES WILL BE USED LATER.

5: LAY THE 2 X 4 X 36-3/4" TOP PANEL BOARD ON TOP OF THE LEFT SIDE CORNER POSTS.

6: USE 5/16 X 4-1/2" HEX BOLTS AND 5/16" WASHERS TO ATTACH THE COUNTERSUNK HOLES OF THE TOP PANEL BOARD TO THE T-NUTS INSTALLED ON THE CORNER POSTS.

7: DO NOT INSTALL LAG SCREWS AT THIS TIME.

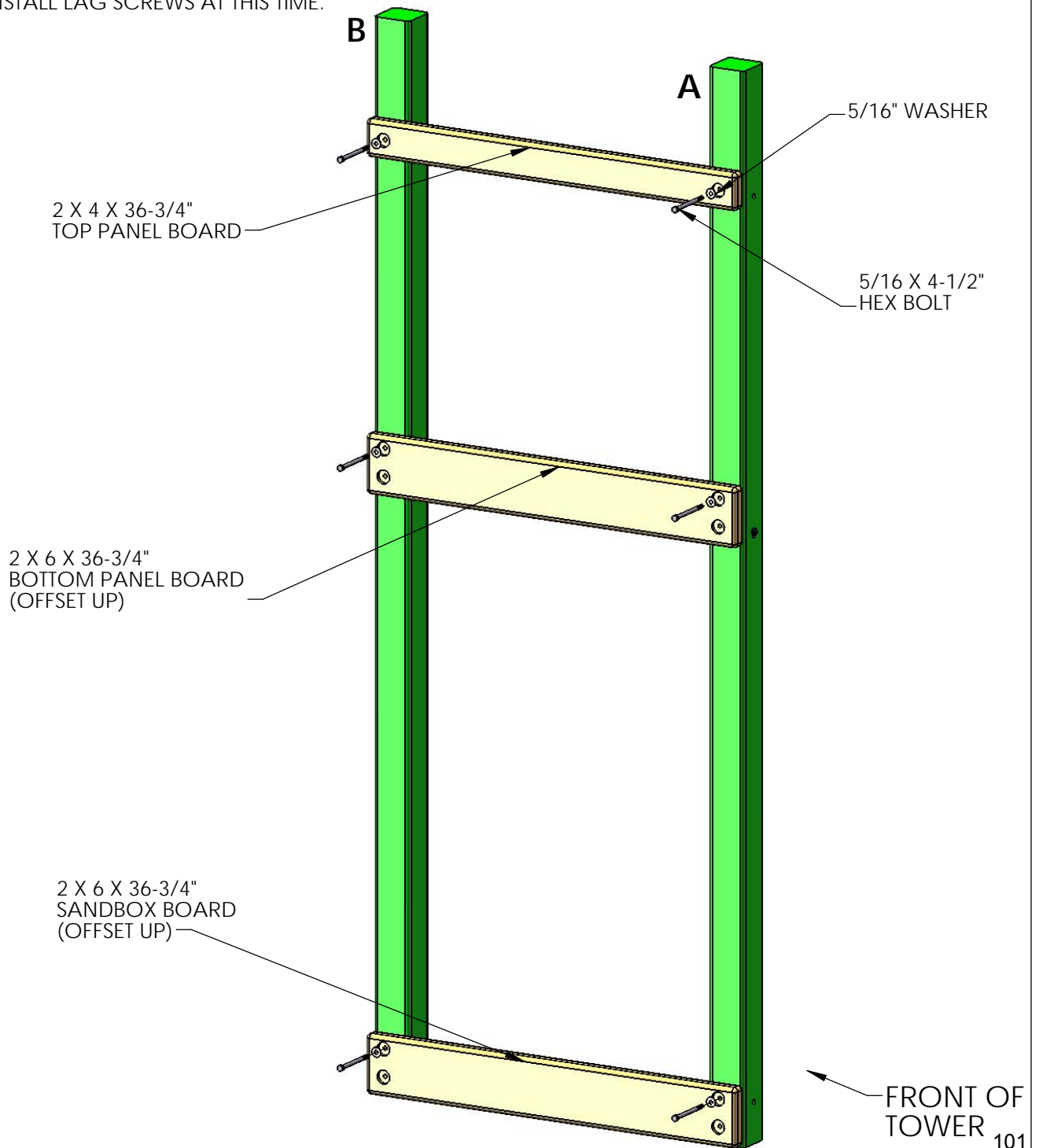

STEP 4: DRILLING CHAIN HOLES

- 1: LOCATE **TWO** 2 X 4 X 36-3/4" BOTTOM PANEL/DECK SUPPORT BOARDS.
- 2: PLACE ONE OF THE BOARDS WITH THE COUNTERSUNK HOLES FACING UP OVER A SCRAP 2 X 4 BOARD. THE SCRAP BOARD WILL HELP PREVENT THE PADDLE BIT FROM SPLINTERING OUT THE BACK SIDE OF THE BOARD.
- 3: MEASURE AND MAKE A MARK AT THE LOCATIONS SHOWN BELOW.
- 4: DRILL A 1" DIAMETER HOLE WITH A PADDLE BIT AT EACH LOCATION THROUGH THE BOARD.
- 5: REPEAT SUBSTEPS 2 TO 4 FOR THE SECOND BOARD.

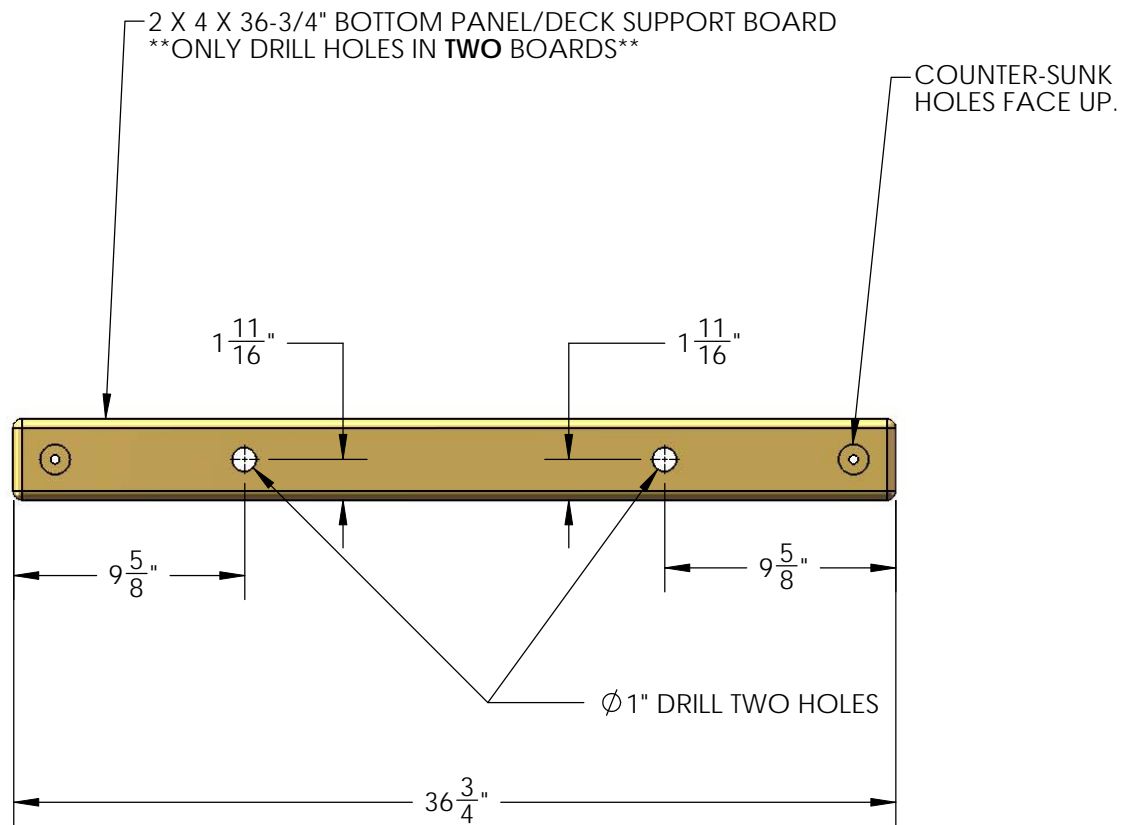

STEP 5: DECK SUPPORTS

YOU WILL NEED AN EXTRA PERSON FOR THIS STEP.

1: WITH HELP, STAND UP THE LEFT AND RIGHT SIDE ASSEMBLIES.

2: FASTEN THE 2 X 4 X 36-3/4" DECK SUPPORTS TO THE HOLES AT 54-1/2" WITH 5/16 X 4-1/2" HEX BOLTS AND 5/16" WASHERS FROM THE INSIDE OF THE CORNER POST.

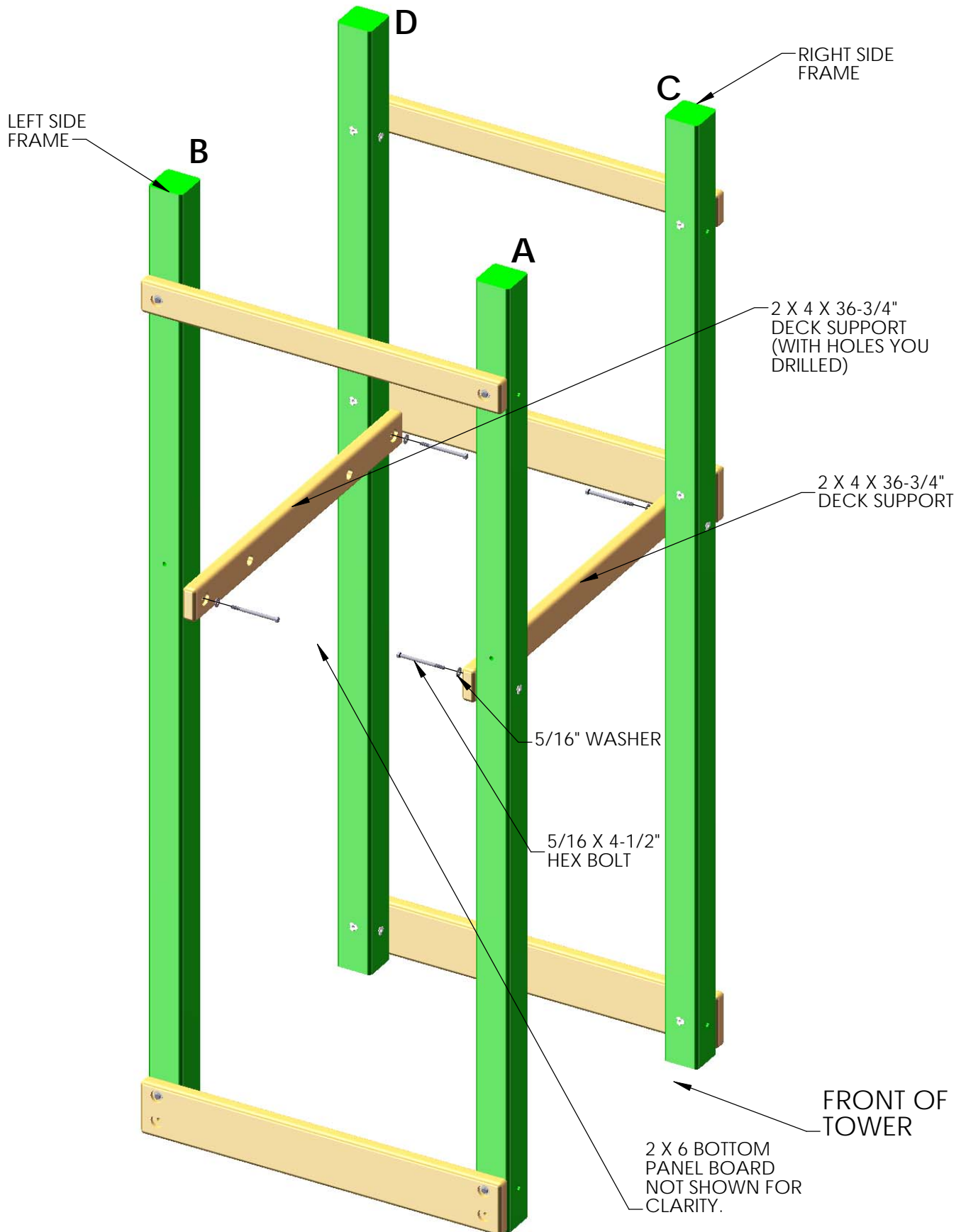

STEP 6: FRONT FRAME ASSEMBLY

1: PLACE THE 2 X 6 X 36-3/4" SANDBOX BOARD ON THE FRONT OF THE CORNER POSTS. THE HOLES IN THE SANDBOX BOARD SHOULD BE OFFSET DOWN.

2: USE 5/16 X 4-1/2" HEX BOLTS AND 5/16" WASHERS TO ATTACH THE TOP HOLES OF THE SANDBOX BOARD TO THE T-NUTS INSTALLED ON THE CORNER POSTS. THE BOTTOM HOLES WILL BE USED LATER.

3: PLACE THE 2 X 4 X 36-3/4" TOP PANEL BOARD ON THE FRONT OF THE CORNER POSTS.

4: USE 5/16 X 4-1/2" HEX BOLTS AND 5/16" WASHERS TO ATTACH THE HOLES OF THE TOP PANEL BOARD TO THE T-NUTS INSTALLED ON THE CORNER POSTS.

5: DO NOT INSTALL LAG SCREWS AT THIS TIME.

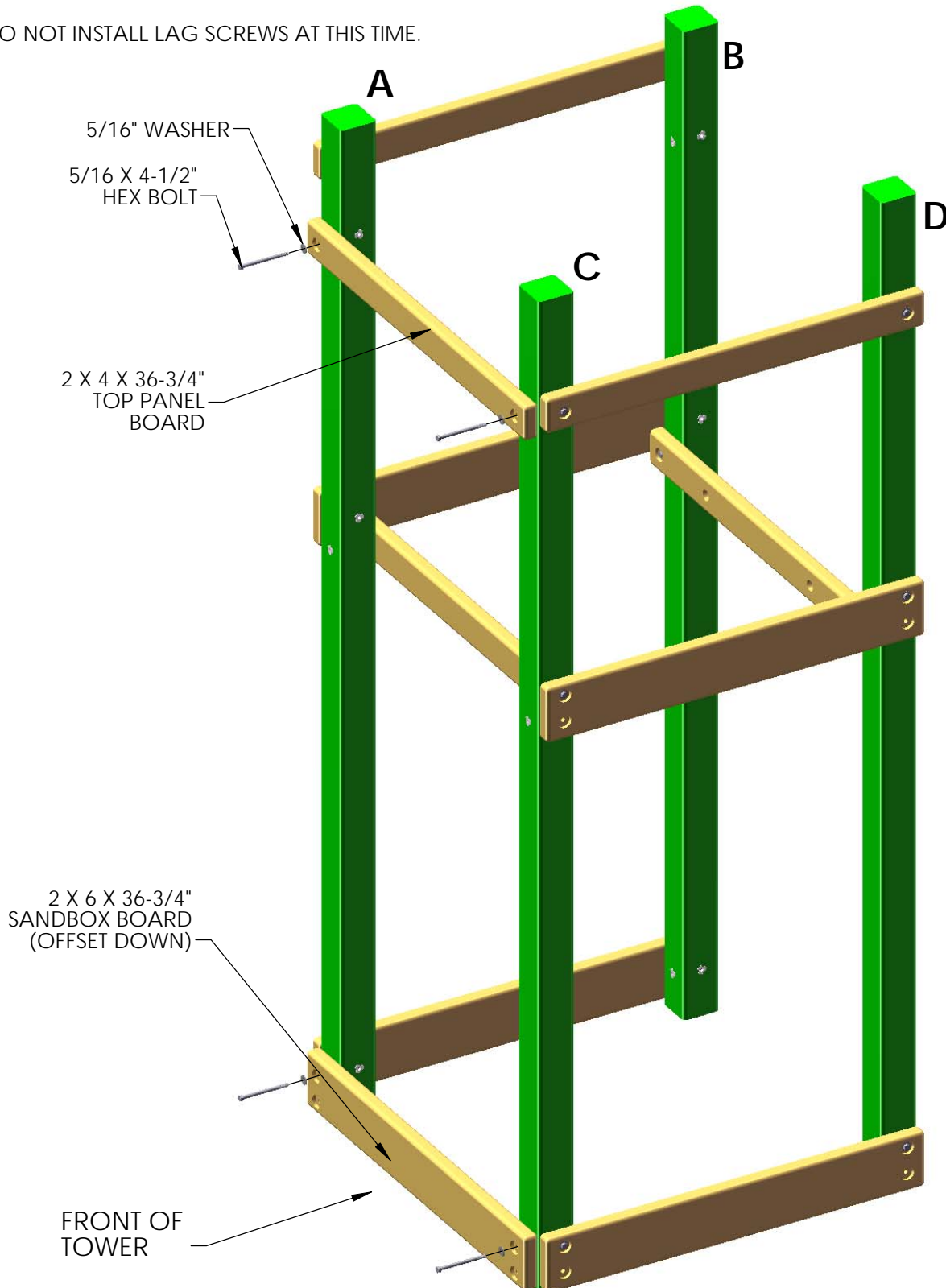

STEP 7: REAR FRAME ASSEMBLY

1: PLACE THE 2 X 6 X 36-3/4" SANDBOX BOARD ON THE REAR OF THE CORNER POSTS. THE HOLES IN THE SANDBOX BOARD SHOULD BE OFFSET DOWN.

2: USE 5/16 X 4-1/2" HEX BOLTS AND 5/16" WASHERS TO ATTACH THE TOP HOLES OF THE SANDBOX BOARD TO THE T-NUTS INSTALLED ON THE CORNER POSTS. THE BOTTOM HOLES WILL BE USED LATER.

3: PLACE THE 2 X 4 X 36-3/4" TOP PANEL BOARD ON THE REAR OF THE CORNER POSTS.

4: USE 5/16 X 4-1/2" HEX BOLTS AND 5/16" WASHERS TO ATTACH THE HOLES OF THE TOP PANEL BOARD TO THE T-NUTS INSTALLED ON THE CORNER POSTS.

5: DO NOT INSTALL LAG SCREWS AT THIS TIME.

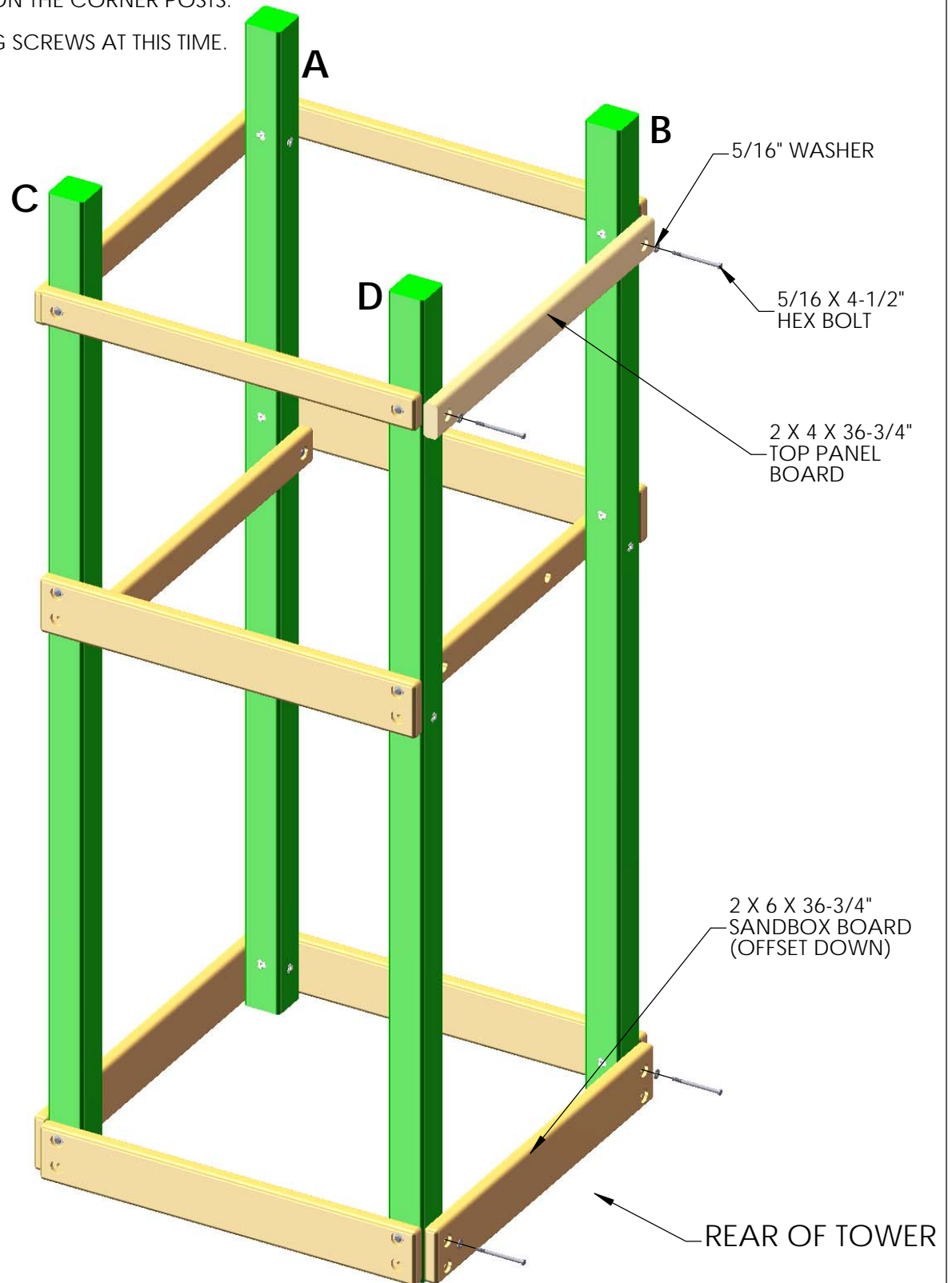

STEP 8: LAG SCREWS

1: PLACE THE FRAME IN ITS FINAL POSITION AND FOLLOW THE PROCEDURES AT THE FRONT OF THE MANUAL TO LEVEL AND SQUARE THE STRUCTURE. TO SQUARE AND LEVEL THE DECK OF THE TOWER TO THE DECK OF THE FORT PLACE A DECK BOARD ACROSS THE 2 X 4'S. THEN PLACE A 2 X 4 X 66" BRIDGE RAIL ON TOP OF THE DECK BOARD AND ON TOP OF THE FORT DECK. PLACE A LEVEL ON TOP OF THE 66" BRIDGE RAIL, THEN MAKE THE DECKS LEVEL TO ONE ANOTHER.

2: ONCE THE FRAME IS LEVEL, SQUARE, AND SET INTO POSITION; GO BACK AND INSERT THE 5/16 X 3-1/2" LAG SCREWS AND 5/16" WASHERS IN THE REMAINING HOLES OF THE 2 X 6 PARTS SHOWN BELOW. NOTE: THERE WILL NOT BE ANY PREDRILLED HOLES IN THE CORNER POSTS FOR THE LAG SCREWS. LAG SCREWS ARE SELF-TAPPING.

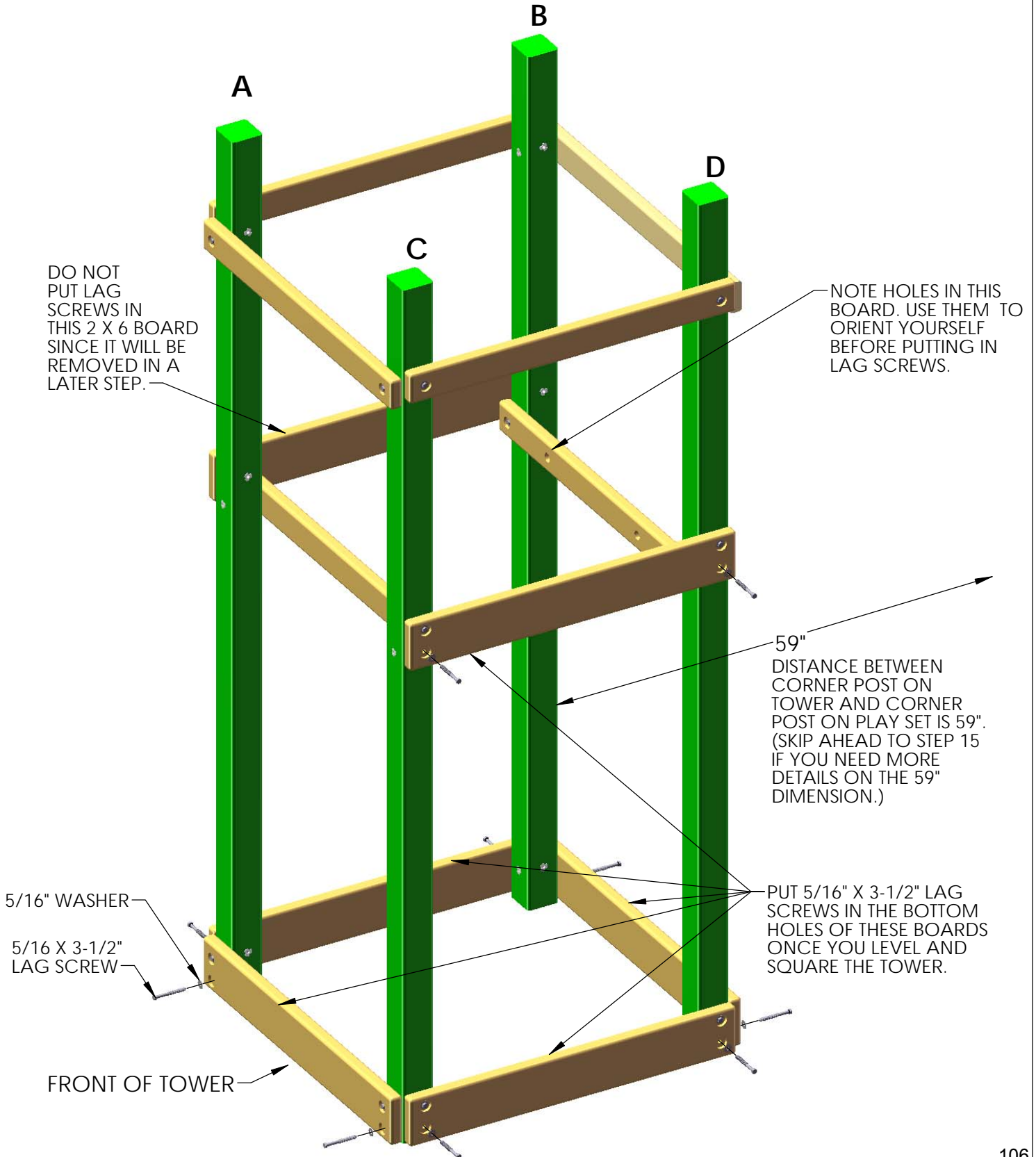

STEP 9: DECK BOARDS

THE FOLLOWING STEP IS RECOMMENDED TO PREVENT POSSIBLE SPLITS IN THE WOOD

1: PRE-DRILL THE ENDS OF THE DECK SPACERS AND DECKBOARDS TO PREVENT INSTALLATION DAMAGE. PRE-DRILL BOTH ENDS WITH A 1/8" DRILL BIT USING THE DIMENSIONS SHOWN BELOW.

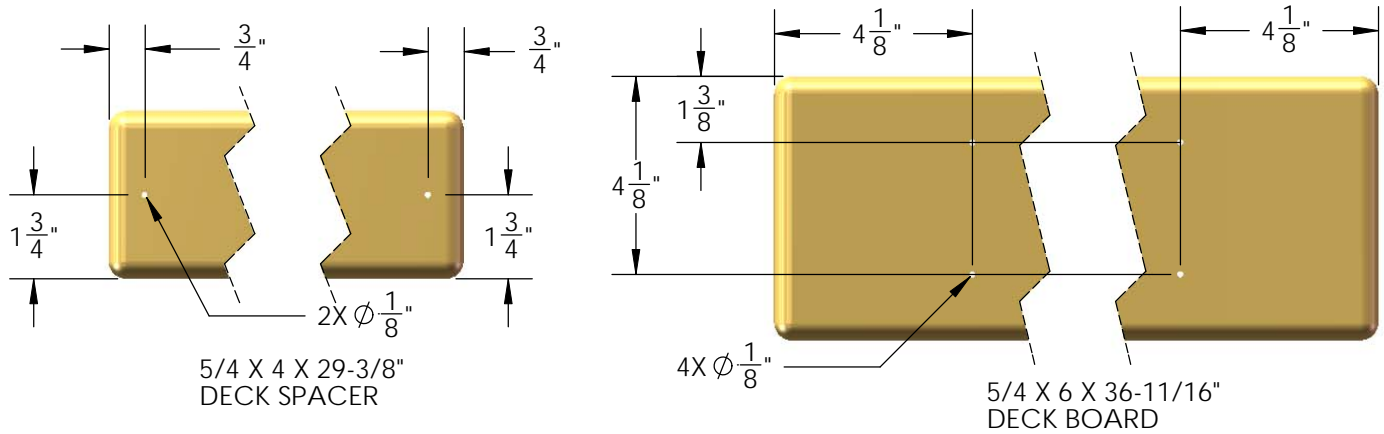

2: PLACE THE 5/4 X 4 X 29-3/8" DECK SPACERS BETWEEN THE CORNER POSTS. MAKE EACH DECK SPACER FLUSH TO THE INSIDE SURFACE OF THE 2 X 6. ATTACH EACH DECK SPACER TO THE DECK SUPPORTS WITH TWO 2" WOOD SCREWS. NOTE THE TOP OF THE SCREW HEAD SHOULD BE FLUSH WITH THE TOP OF THE DECK SPACER.

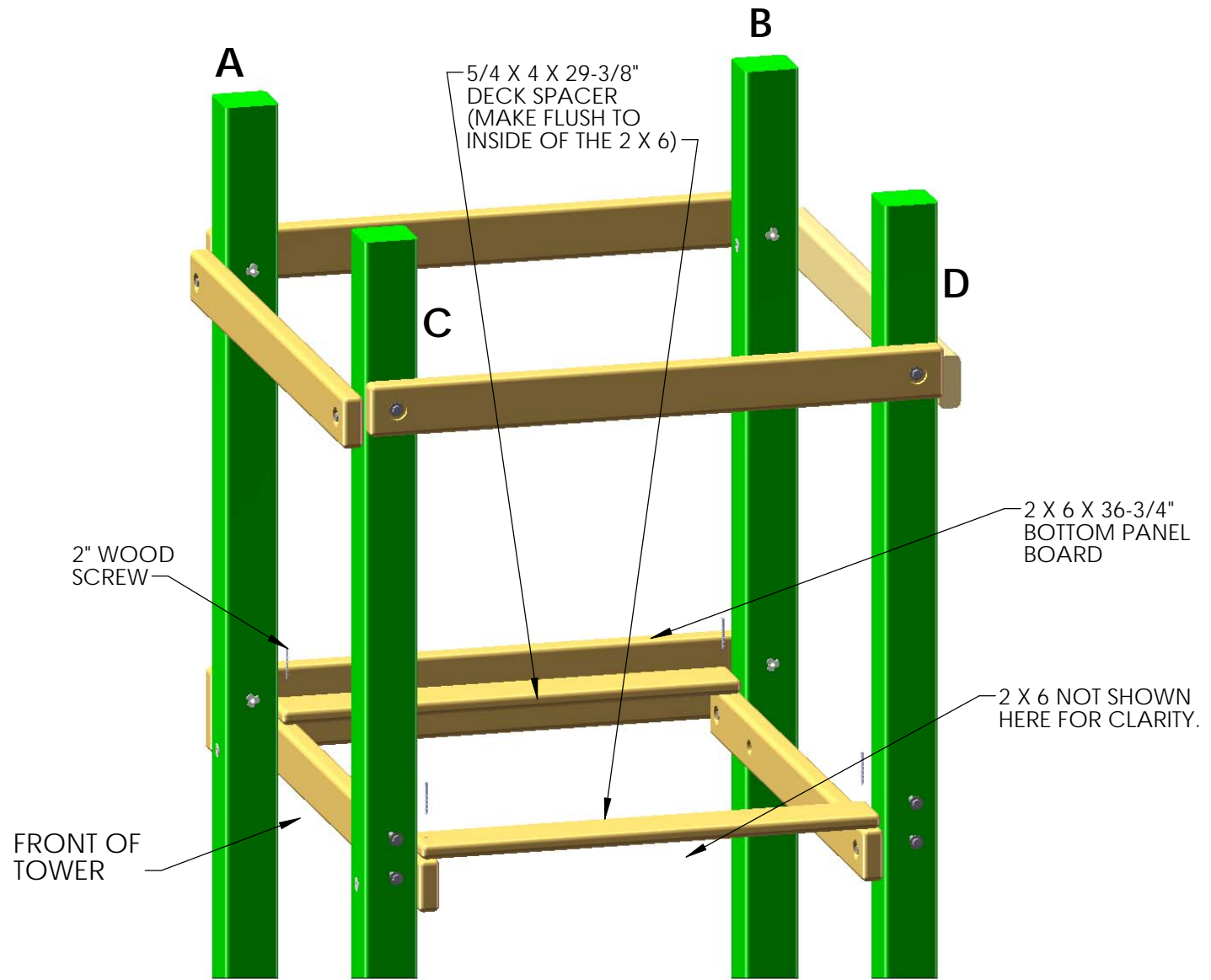

STEP 10: FRONT FACE BOARD

1: PLACE THE 5/4 X 6 X 36-11/16" DECK BOARDS ON TOP OF THE DECK SUPPORTS. DO NOT FASTEN THE DECK BOARDS AT THIS TIME.

2: PLACE THE 2 X 4 X 36-3/4" BOTTOM PANEL BOARD AGAINST THE FRONT CORNER POSTS, AND LEVEL THE TOP OF THE BOARD WITH THE TOP OF THE DECK BOARDS.

3: FASTEN THE BOTTOM PANEL BOARD TO THE CORNER POSTS WITH 5/16 X 3-1/2" LAG SCREWS WITH 5/16" WASHERS.

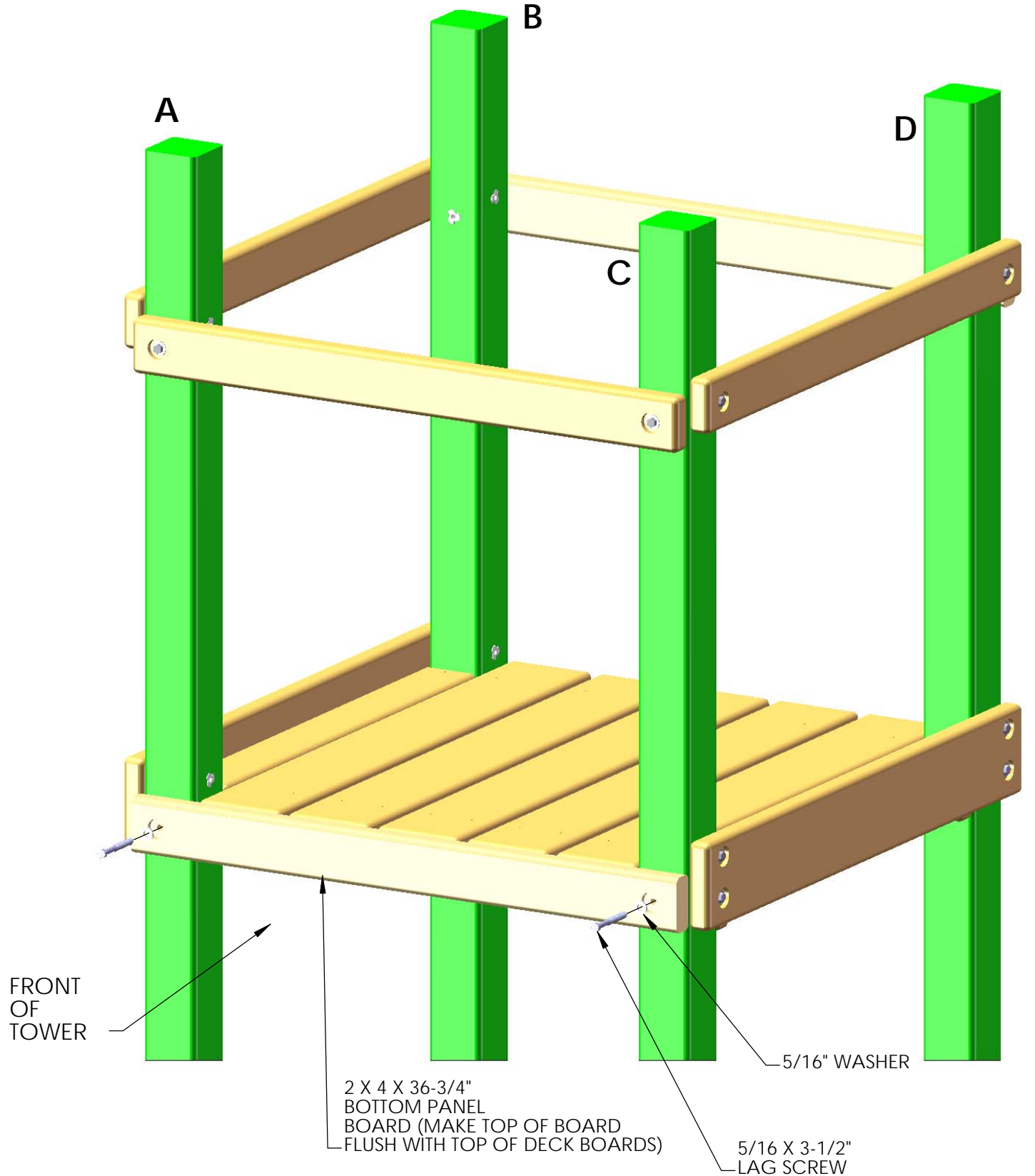

STEP 11: DECK

1: INSTALL THE 5/4 X 6 X 36-11/16" DECK BOARDS. LEAVE A UNIFORM (APPROXIMATELY 5/16") SPACE BETWEEN THE DECK BOARDS. ATTACH THE DECK BOARDS TO THE DECK SUPPORTS WITH WITH 2" WOOD SCREWS.

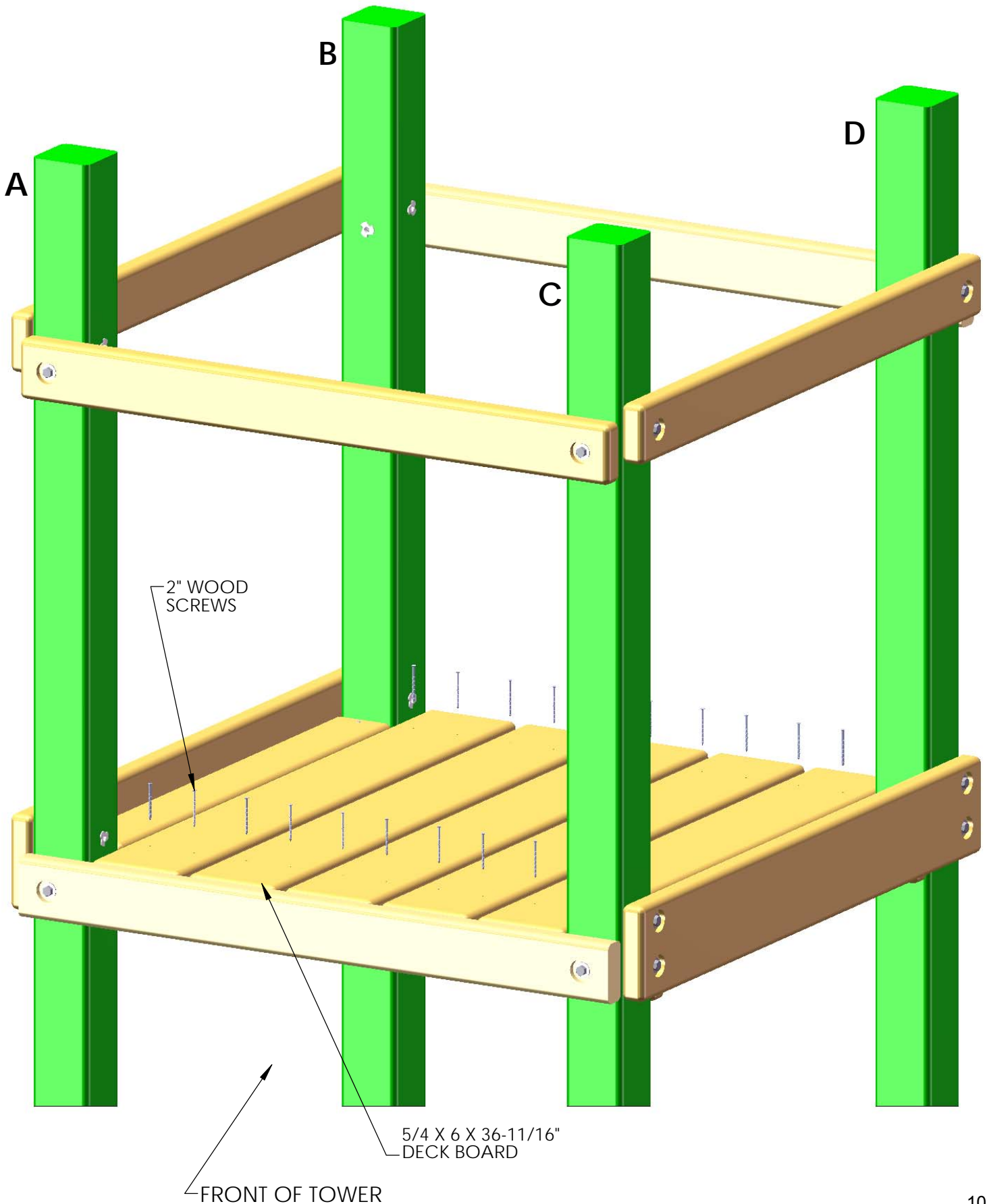

STEP 12: REAR BOTTOM PANEL BOARD

1: PLACE THE 2 X 4 X 36-3/4" BOTTOM PANEL BOARD (WITH HOLES YOU DRILLED) AGAINST THE REAR CORNER POSTS, AND LEVEL THE TOP OF THE BOARD WITH THE TOP OF THE DECK BOARDS.

2: FASTEN THE BOTTOM PANEL BOARD TO THE CORNER POSTS WITH 5/16 X 3-1/2" LAG SCREWS WITH 5/16" WASHERS.

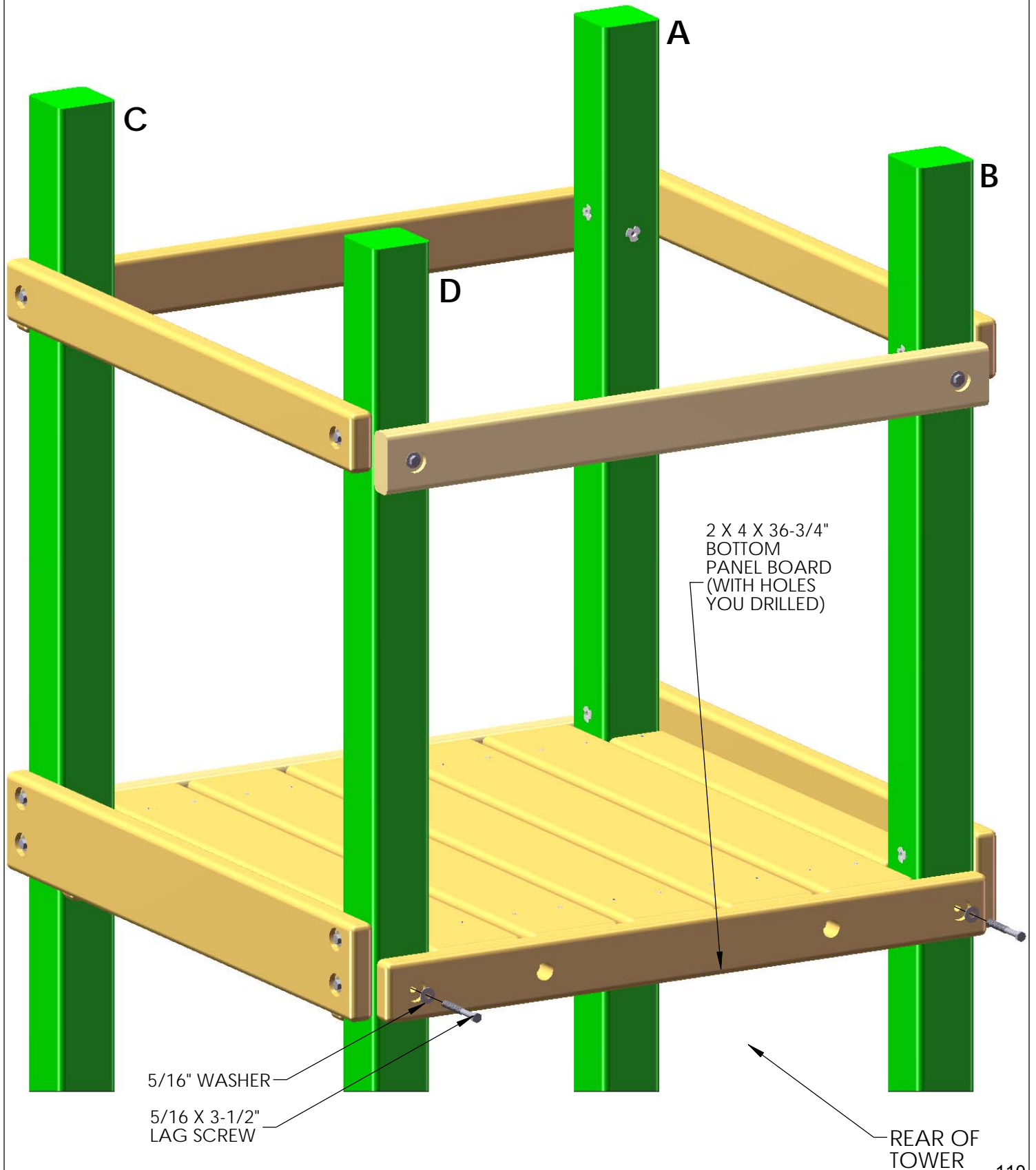

STEP 13: PANEL SLATS

1: FIND FIVE 5/4 X 3 X 28-1/2" PANEL SLATS.

2: PRE-DRILL THE PANEL SLATS 1" FROM EACH END ON CENTER WITH A 1/8" DRILL BIT. (SEE TOP LEFT PICTURE BELOW)

3: INSTALL THE FIRST PANEL SLAT 2-1/2" FROM THE CORNER POST. THEN INSTALL THE REMAINING FOUR PANEL SLATS 2-7/8" APART AS SHOWN IN THE PICTURE AT THE BOTTOM LEFT BELOW.

4: ATTACH THE PANEL SLATS WITH 2" WOOD SCREWS IN THE PRE-DRILLED HOLES TO THE RIGHT SIDE OF THE TOWER.

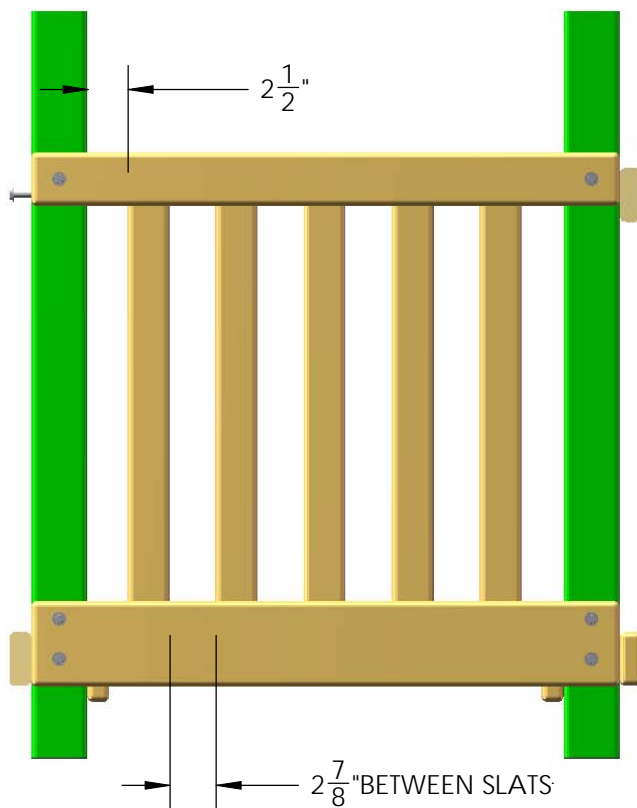
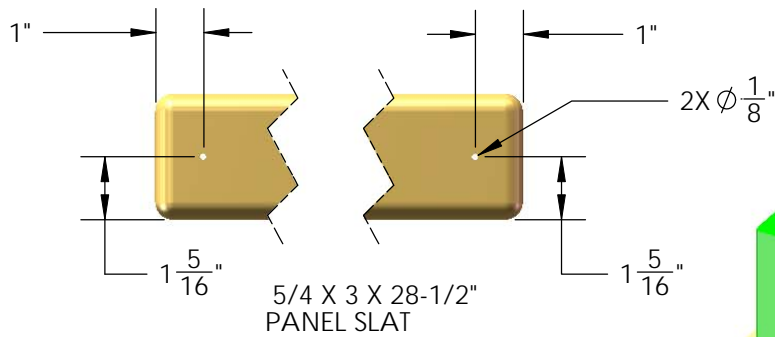

RIGHT SIDE VIEW OF SLATS.

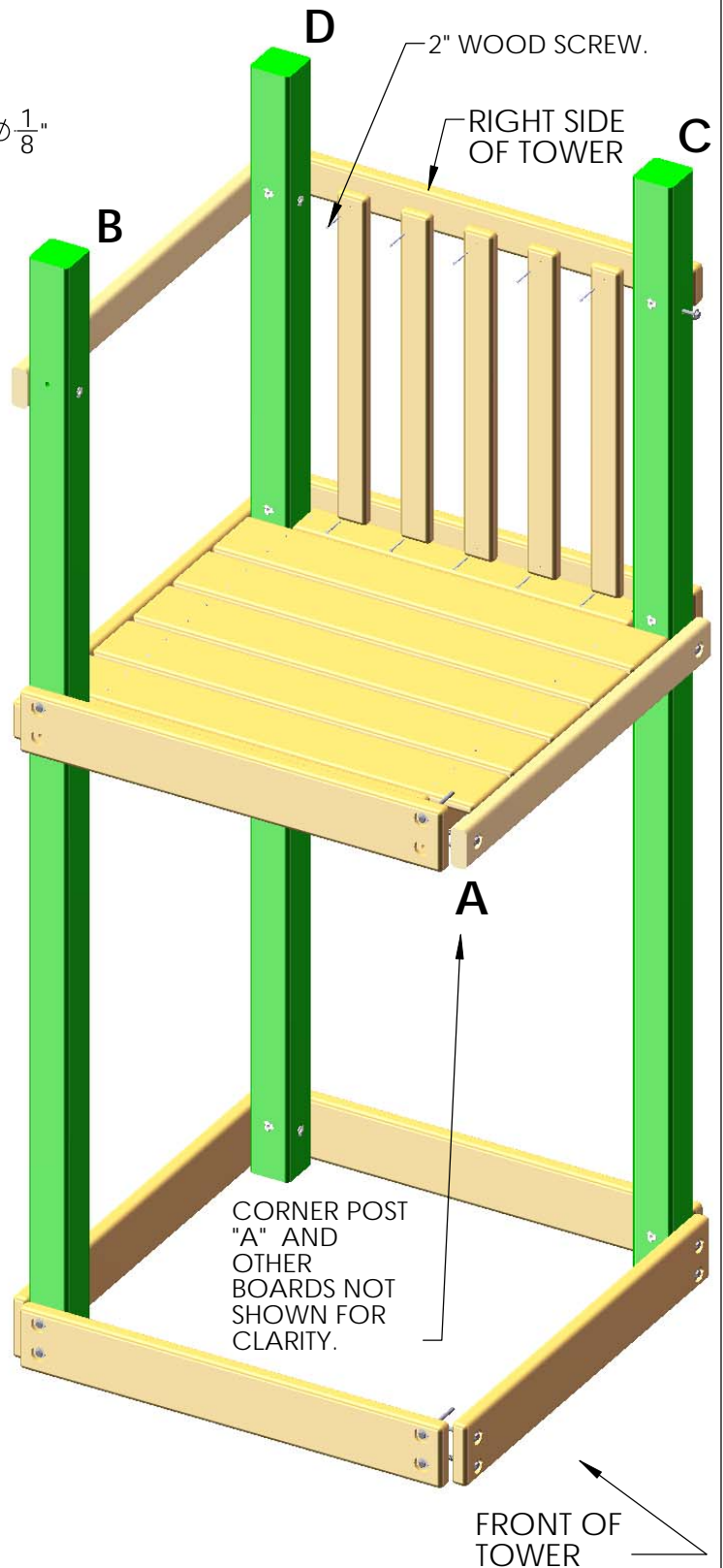

STEP 14: BRIDGE RAILS

- 1: PLACE THE TOP SURFACE OF THE UPPER TWO 2 X 4 X 66" BRIDGE RAILS 5-1/2" BENEATH THE TOP SURFACE OF THE TOP PANEL BOARD. THE COUNTERSUNK HOLE IN THE END OF THE BRIDGE RAIL SHOULD FACE THE INSIDE. FASTEN THE BRIDGE RAIL TO THE CORNER POST WITH 5/16" X 3-1/2" LAG SCREWS WITH 5/16" WASHERS.
- 2: MEASURE 16" FROM THE TOP OF EACH BRIDGE RAIL AND MAKE A PENCIL MARK ON THE INSIDE OF THE CORNER POSTS.
- 3: PLACE THE BOTTOM OF EACH LOWER 2 X 4 X 66" BRIDGE RAIL ON THE MARK ON THE CORNER POST. FASTEN EACH BRIDGE RAIL TO THE CORNER POST WITH 5/16" X 3-1/2" LAG SCREWS WITH 5/16" WASHERS.

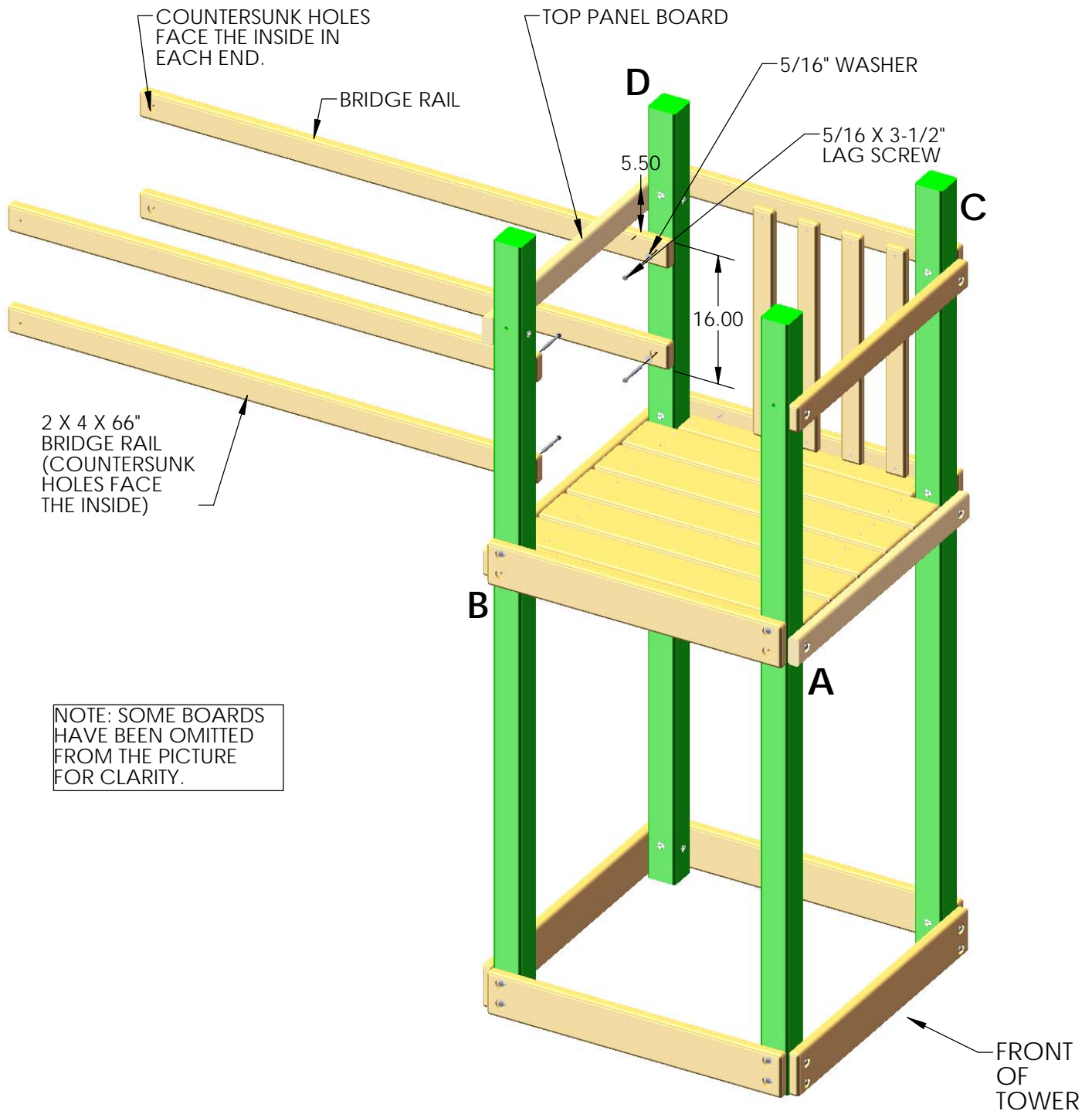

STEP 15: BRIDGE RAILS TO PLAY SET

- 1: PLACE THE BRIDGE RAILS AGAINST THE GREEN CORNER POST AND CENTER CORNER POST ON THE PLAY SET.
- 2: LEVEL EACH TOP BRIDGE RAIL AND ATTACH THEM TO THE CORNER POSTS WITH 5/16" X 3-1/2" LAG SCREWS AND 5/16" WASHERS.
- 3: MAKE THE BOTTOM OF EACH LOWER BRIDGE RAIL 16" FROM THE TOP OF THE TOP BRIDGE RAIL.
- 4: ATTACH EACH LOWER BRIDGE RAIL TO THE CORNER POSTS WITH 5/16" X 3-1/2" LAG SCREWS AND 5/16" WASHERS.

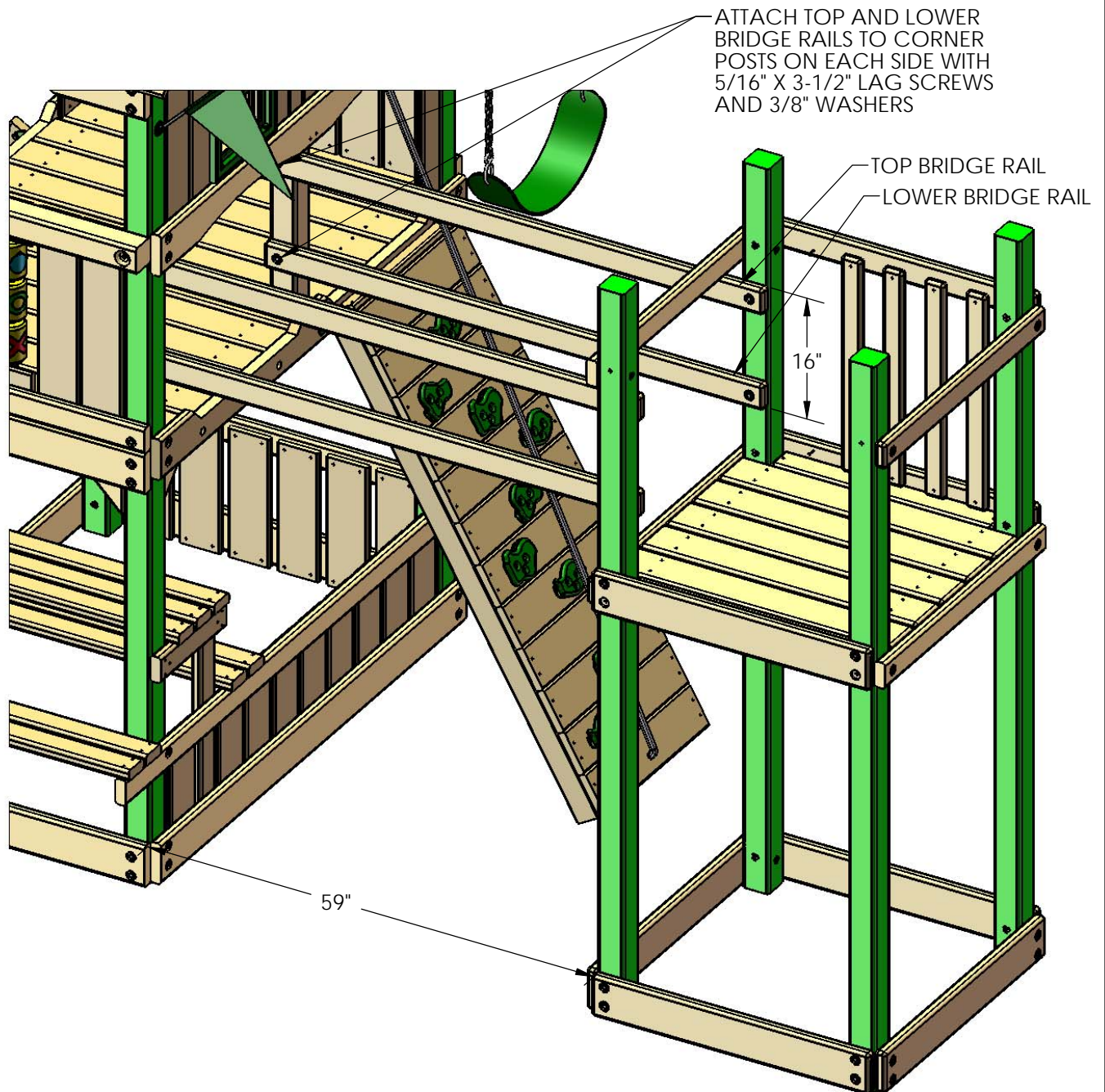

STEP 16: BRIDGE RAIL SLATS

1. PRE-DRILL THE 5/4 X 3 X 16" BRIDGE RAIL SLATS ON EACH END WITH A 1/8" DRILL BIT. (SEE TOP IMAGE BELOW)
2. PLACE THE BRIDGE RAIL SLATS 3" FROM THE FACE OF THE CORNER POSTS, AND ATTACH WITH 2" WOOD SCREWS. THE SLATS WILL MOUNT ON THE OUTSIDE OF THE BRIDGE RAILS.
3. ATTACH THE REMAINING SLATS TO THE UNIT WITH 3" SPACING BETWEEN THE SLATS.

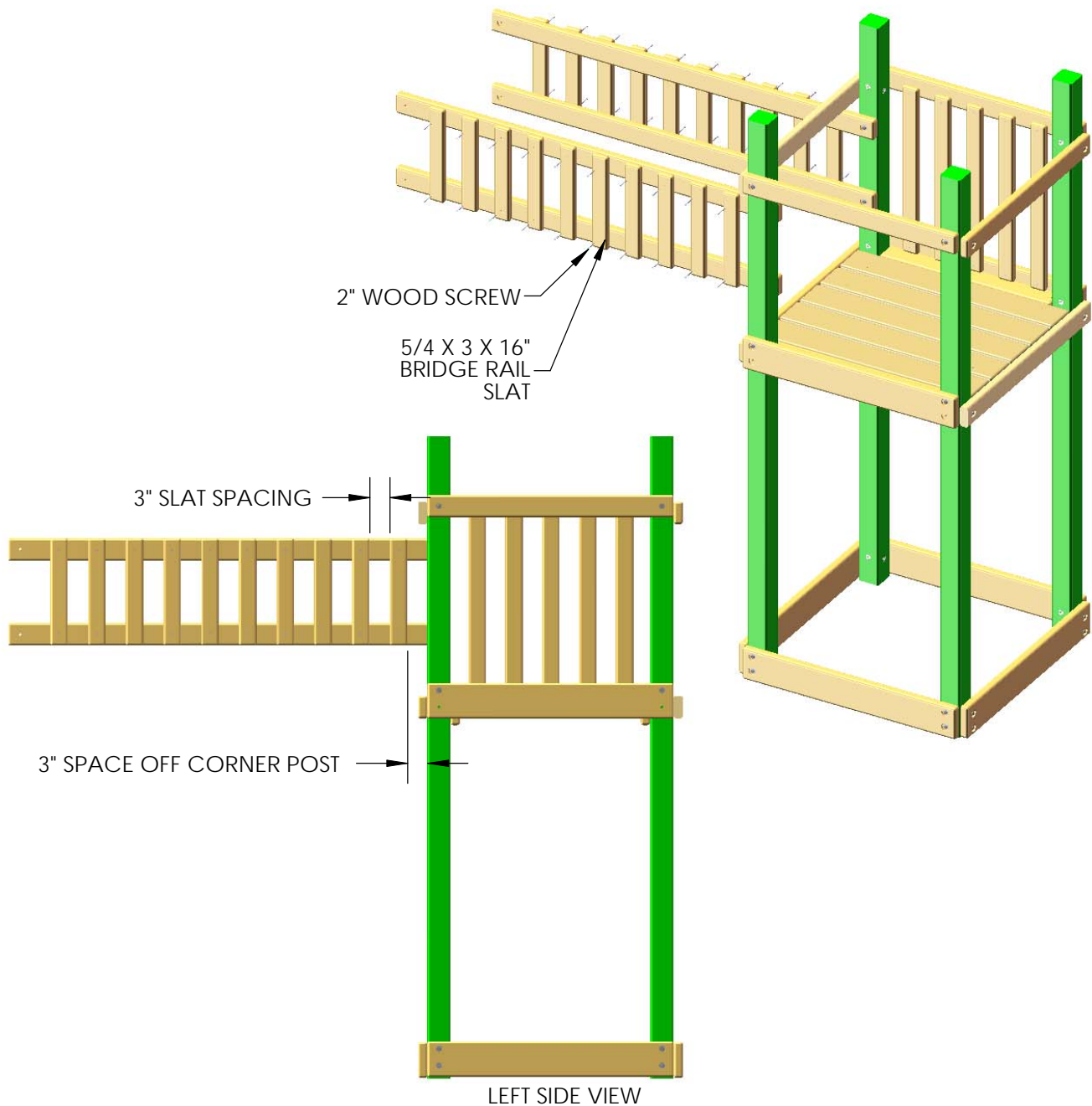
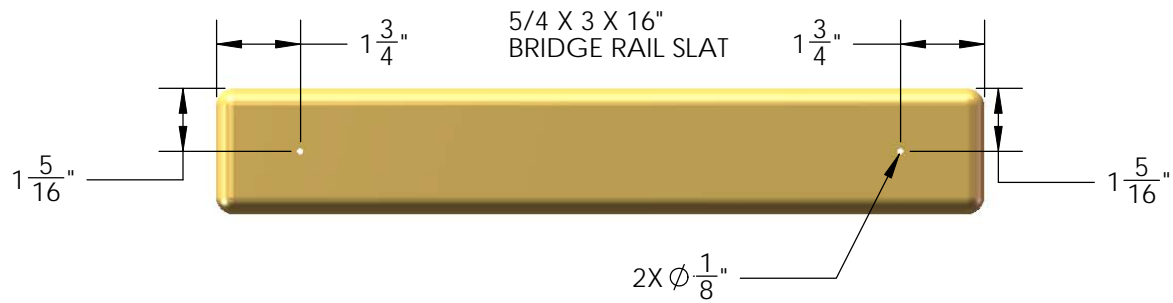

STEP 17: BRIDGE DECK AND CHAIN ASSEMBLY

1: FIND FIFTEEN 2 X 4 X 29" BRIDGE DECK BOARDS AND INSERT T-NUTS INTO THE PRE-DRILLED HOLES. USE A HAMMER TO SEAT THE T-NUTS INTO THE BOARDS.

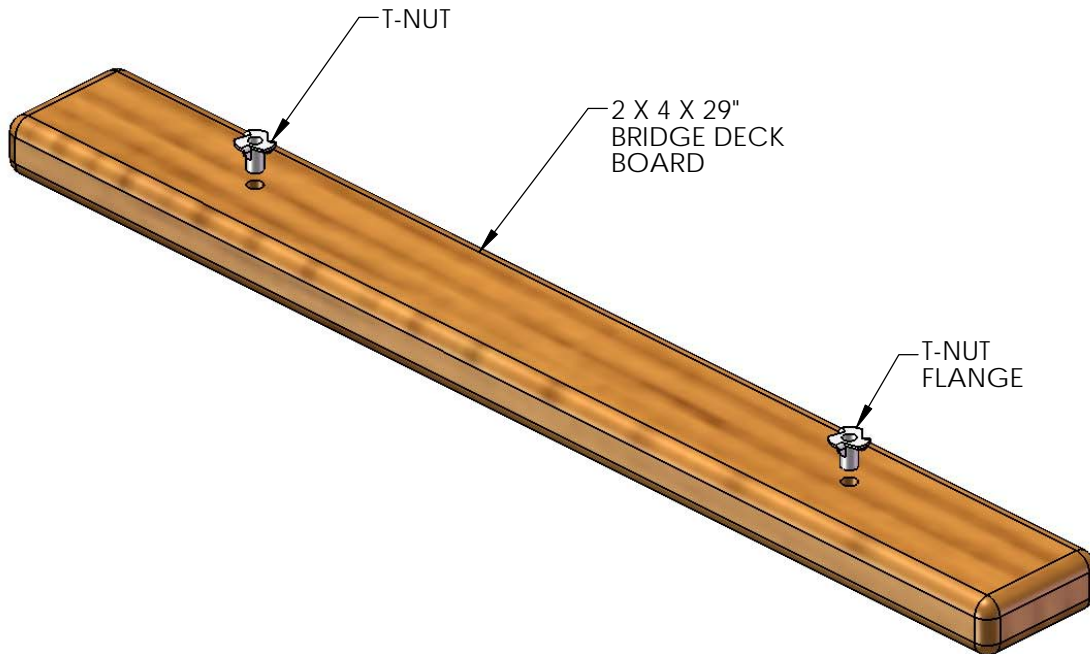

2: FLIP ALL 15 BRIDGE DECK BOARDS OVER SO THAT THE FLANGE OF THE T-NUT IS FACING DOWN. LAY THE BRIDGE DECK BOARDS OUT ON A FLAT SURFACE AS SHOWN BELOW.

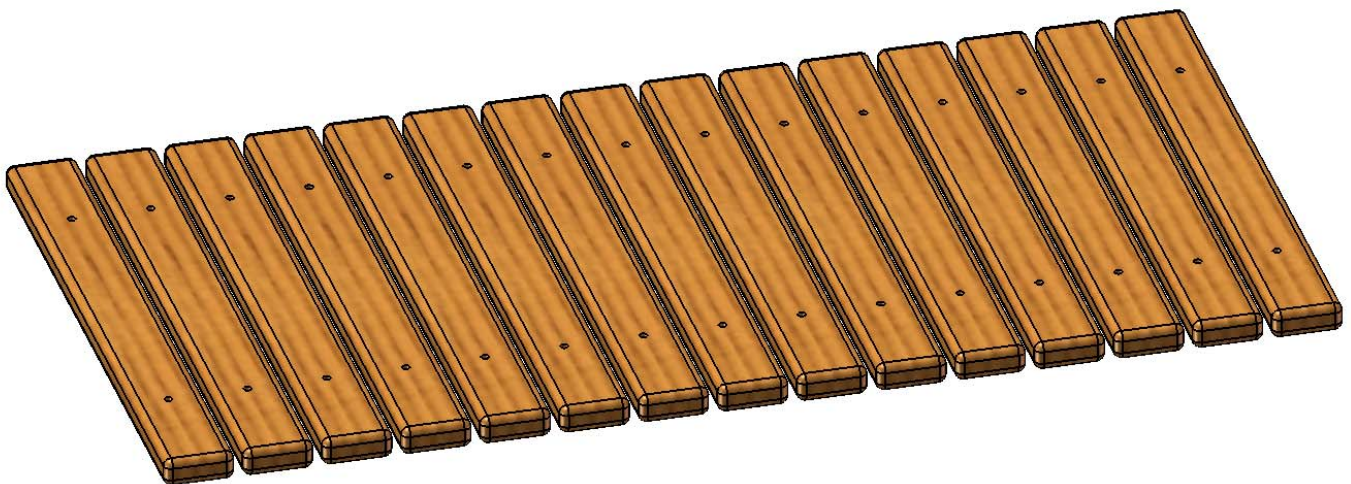

STEP 18: BRIDGE DECK AND CHAIN ASSEMBLY

- 1: LOCATE TWO 96" CHAIN SECTIONS THAT SHIPPED WITH THE CLATTER BRIDGE.
- 2: PLACE THE CHAINS OVER THE HOLES IN THE BRIDGE DECK BOARDS AS SHOWN BELOW.
- 3: LINE UP THE 18TH LINK IN THE CHAINS WITH THE FIRST BRIDGE DECK BOARD HOLES.

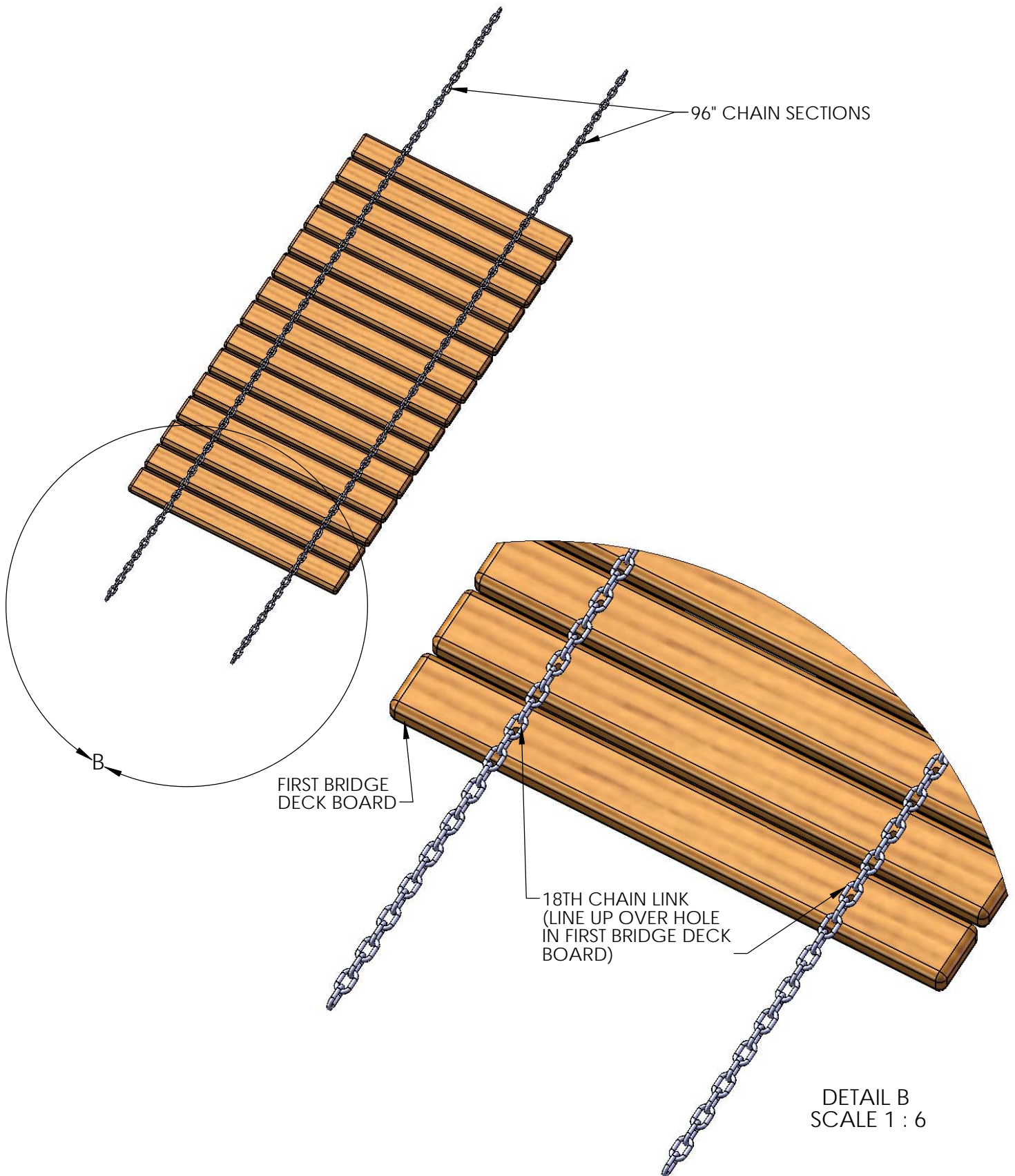

STEP 19: BRIDGE DECK AND CHAIN ASSEMBLY

- 1: PLACE A 5/16" WASHER BETWEEN THE 18TH CHAIN LINK AND THE BRIDGE DECK BOARD.
- 2: PLACE A 5/16" X 1-3/4" HEX BOLT WITH 5/16" WASHER THROUGH THE 18TH CHAIN LINK, THEN THROUGH THE 5/16" WASHER, THEN THROUGH THE HOLE IN THE BRIDGE DECK BOARD AND SCREW IT INTO THE T-NUT. TIGHTEN THE BOLT BUT NOT SO TIGHT THAT YOU CRACK THE WOOD.
- 3: COUNT OVER 4 CHAIN LINKS FROM THE LAST HEX BOLT. AT THIS CHAIN LINK PLACE A 5/16" WASHER BETWEEN THE CHAIN LINK AND THE BRIDGE DECK BOARD. NOTE THAT THREE EMPTY CHAIN LINKS ARE BETWEEN THE BOLTS.
- 4: PLACE A 5/16" X 1-3/4" HEX BOLT WITH 5/16" WASHER THROUGH THE CHAIN LINK, THEN THROUGH THE 5/16" WASHER, THEN THROUGH THE HOLE IN THE BRIDGE DECK BOARD AND SCREW IT INTO THE T-NUT. TIGHTEN THE BOLT BUT NOT SO TIGHT THAT YOU CRACK THE WOOD.
- 5: REPEAT SUBSTEPS 3 & 4 UNTIL YOU HAVE SECURED THE CHAIN TO THE BRIDGE DECK BOARDS ALONG ONE SIDE. THEN START OVER WITH THE OTHER CHAIN AND REPEAT THIS ENTIRE PROCESS.

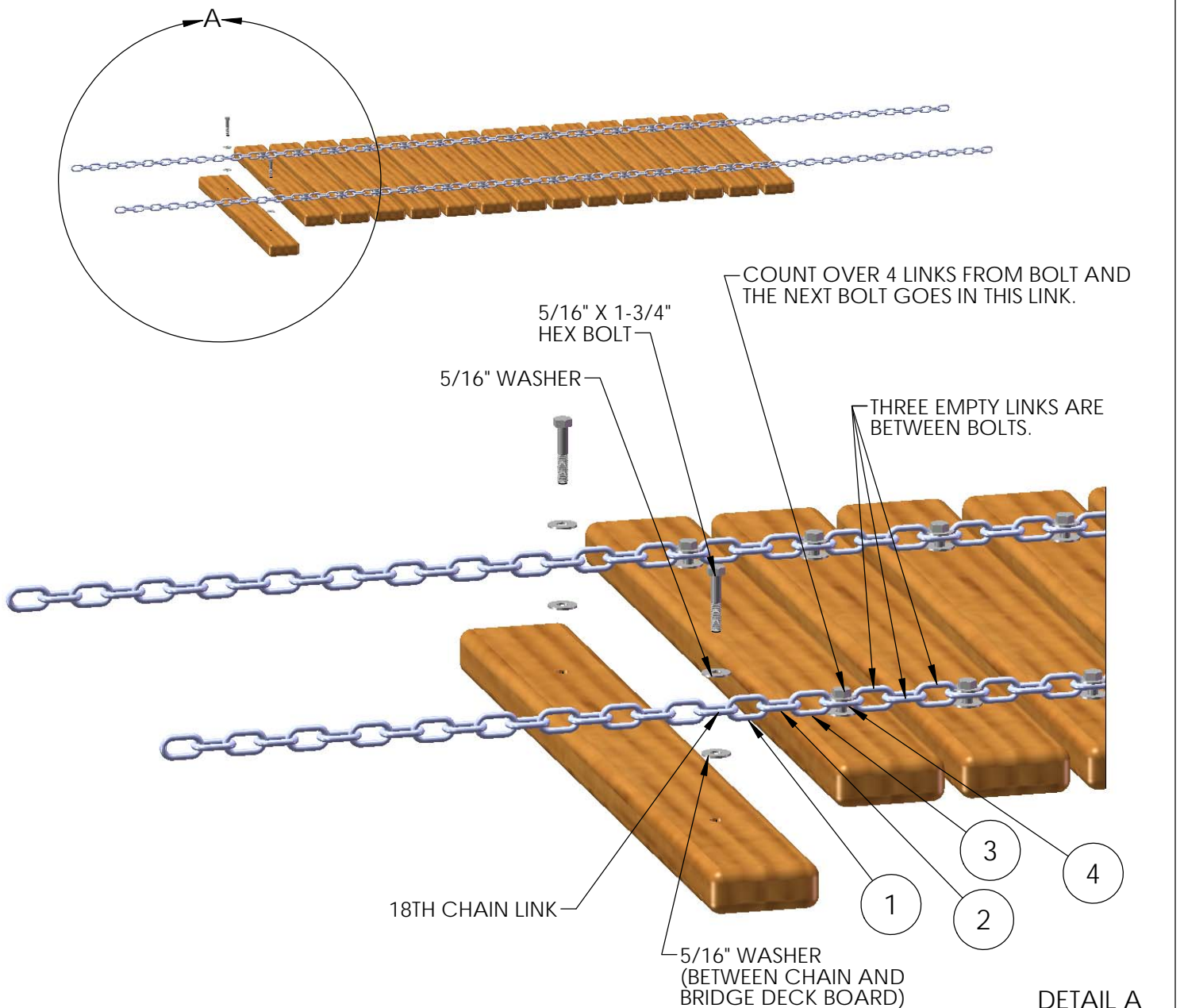

STEP 20: BRIDGE DECK/CHAIN INSTALLATION

1: LAY THE BRIDGE DECK/CHAINS ASSEMBLY BETWEEN THE PLAY SET AND THE TOWER WITH THE CHAINS FACING THE GROUND. THREAD THE CHAIN ENDS IN THE BRIDGE DECK ASSEMBLY THROUGH THE HOLES IN THE BOTTOM PANEL BOARD AND DECK SUPPORT BOARD ON THE TOWER.

2: THERE SHOULD BE AT LEAST A 1" TO 1-3/4" GAP BETWEEN THE BRIDGE DECK BOARD AND THE BOTTOM PANEL BOARD ON THE TOWER. THIS MEANS THAT YOU WILL HAVE TO CONNECT THE ENDS OF THE CHAINS IN A MANNER TO ACHIEVE THE CORRECT GAP. GO UNDERNEATH THE TOWER DECK AND USE A QUICK LINK TO ATTACH THE CHAINS TOGETHER. IF YOU HAVE LOOSE ENDS OF THE CHAINS HANGING DOWN THREAD THEM THROUGH THE QUICK LINK TO KEEP THEM UP AND OUT OF THE WAY.

3: REPEAT THIS PROCESS AT THE PLAY SET TO ATTACH THE CHAINS. AT THE PLAY SET EACH CHAIN MUST GO THROUGH TWO BOARDS. **NO EXCEPTIONS.**

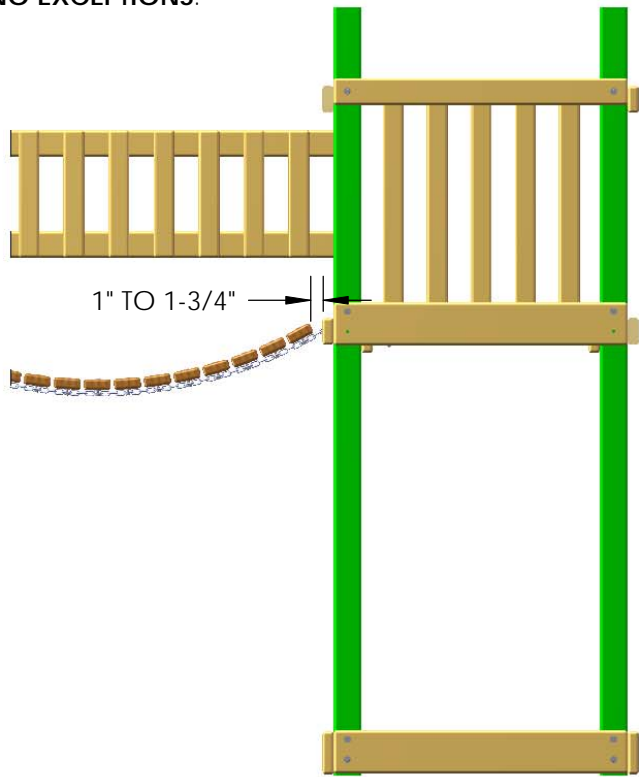

CHAIN MUST GO THROUGH TWO BOARDS **NO EXCEPTIONS!!**

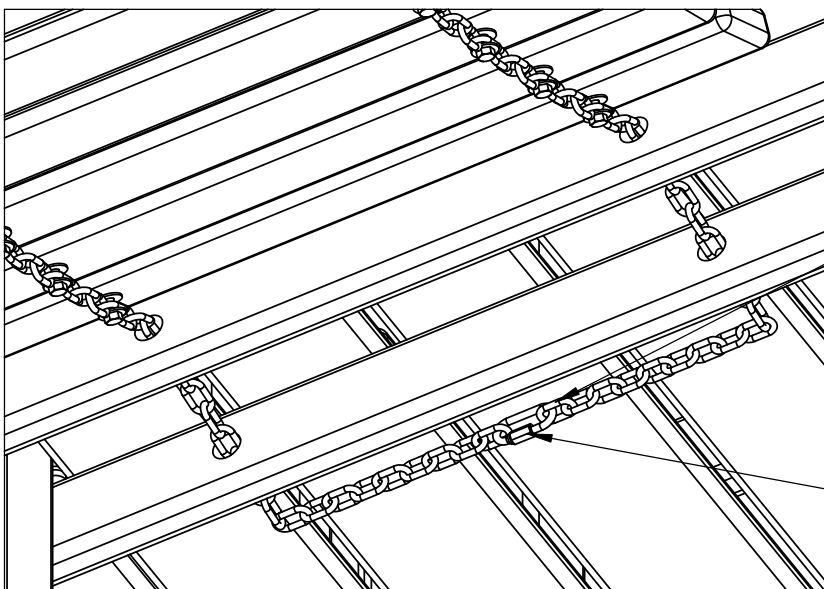
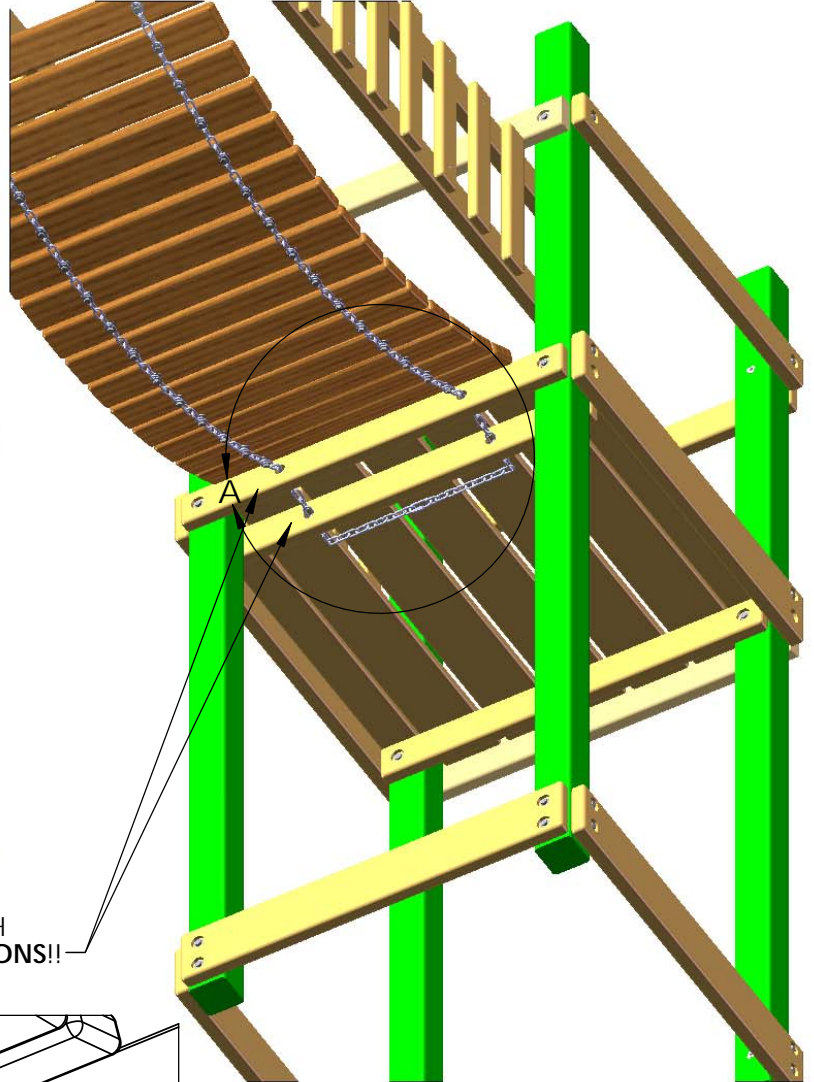

DETAIL A
SCALE 1 : 6

NOTE: TO ACHIEVE THE CORRECT GAP YOU MAY NOT BE CONNECTING THE END LINK OF EACH CHAIN. FOR EXAMPLE YOU MAY HAVE TO CONNECT THE SECOND, THIRD OR FORTH LINKS TOGETHER.

QUICK LINK

STEP 21: LAG POSTS

1: LOCATE TWO 4 X 4 X 32" LAG POSTS.

2: PLACE THE LAG POSTS ON THE INSIDE OF CORNER POSTS A AND B AS SHOWN. THE COUNTERSUNK HOLE THAT IS 4" FROM THE END SHOULD BE AT THE TOP.

3: ATTACH EACH LAG POST TO THE CORNER POST WITH 3/8" X 5" LAG SCREWS AND 3/8" WASHERS.

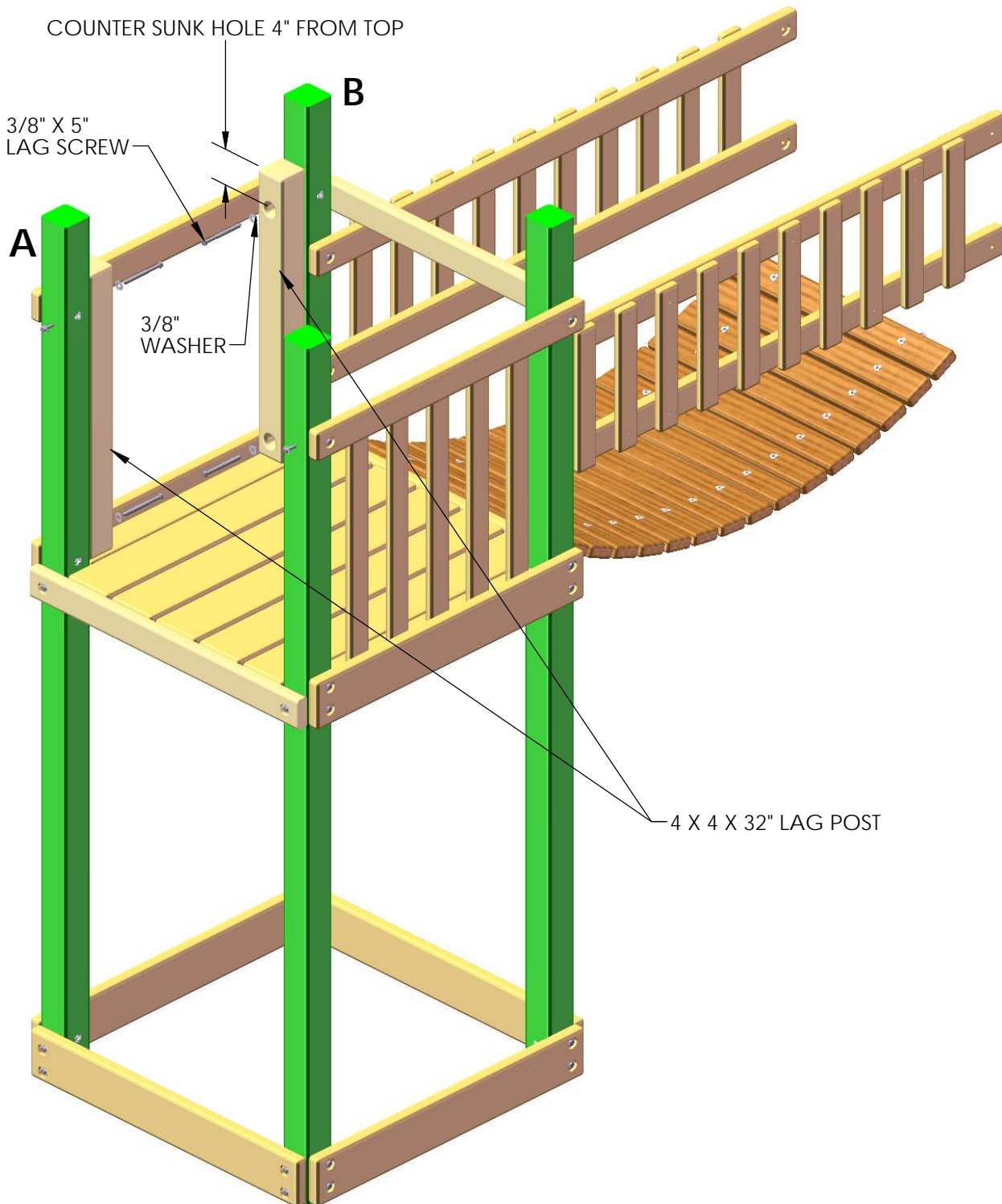

STEP 22: VERTICAL TARP SUPPORTS

1: PLACE THE 2 X 4 X 33" VERTICAL TARP SUPPORTS ON THE INSIDE OF THE TOP PANEL BOARDS. THE END OF EACH VERTICAL TARP SUPPORT SHOULD BE FLUSH TO THE BOTTOM OF THE TOP PANEL BOARD. CENTER EACH VERTICAL TARP SUPPORT WITH THE CENTER OF THE TOP PANEL BOARD. SQUARE EACH VERTICAL TARP SUPPORT TO THE TOP PANEL BOARD.

2: ATTACH THE VERTICAL TARP SUPPORTS TO THE TOP PANEL BOARDS WITH 2-1/2" WOOD SCREWS.

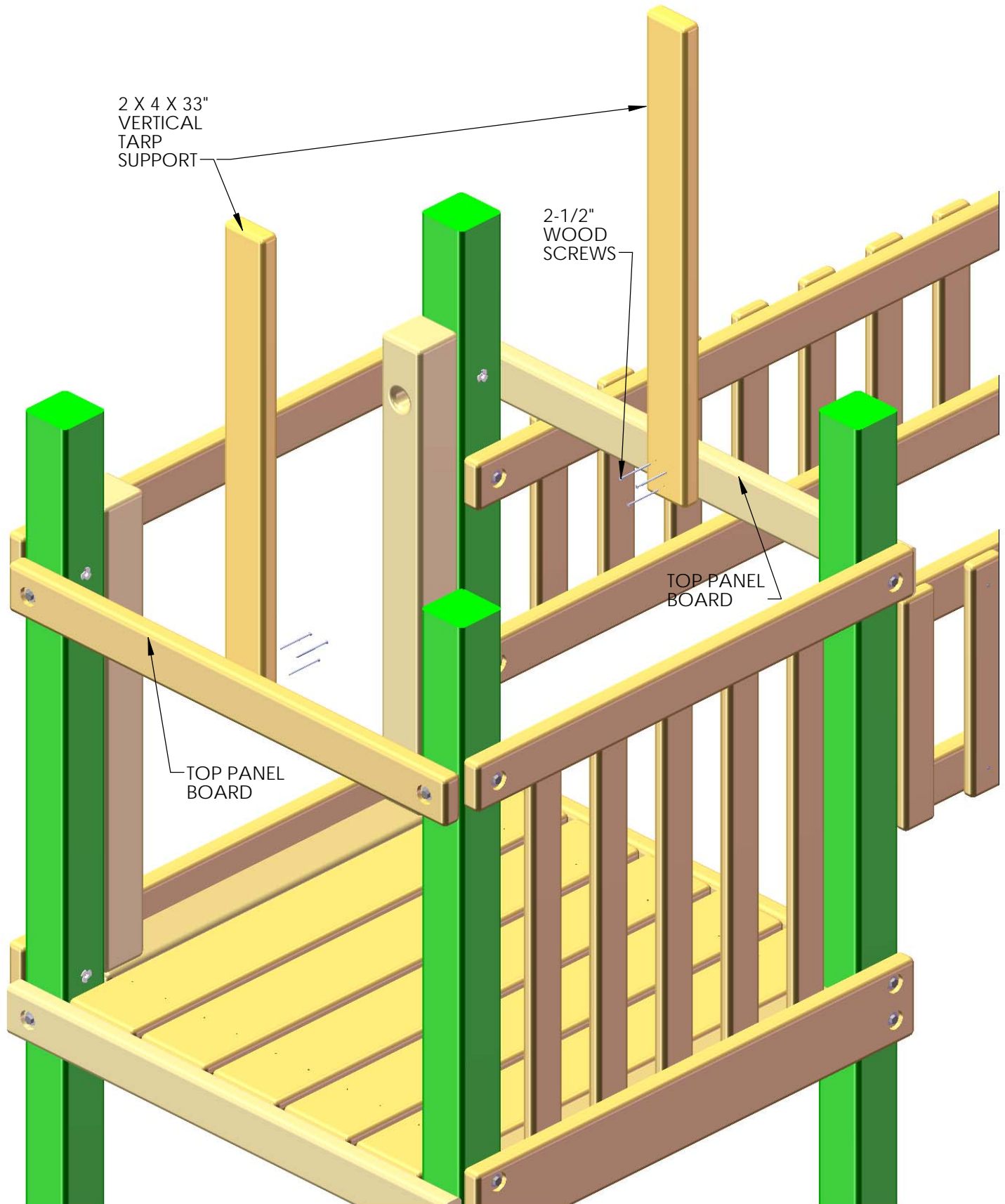

STEP 23: TARP BOARDS

- 1: LOCATE THREE 2 X 4 X 36-3/4" TARP BOARDS.
- 2: PLACE ONE TARP BOARD ON TOP OF THE VERTICAL TARP SUPPORTS. THE END OF THE TARP BOARD SHOULD BE FLUSH WITH THE SIDES OF THE VERTICAL TARPS SUPPORTS.
- 3: ATTACH THE TARP BOARD TO THE VERTICAL TARP SUPPORTS WITH 2-1/2" WOOD SCREWS.
- 4: PLACE ONE TARP BOARD ON TOP OF THE CORNER POSTS. THE TARP BOARD SHOULD BE FLUSH TO THE OUTSIDE OF THE CORNER POST.
- 5: ATTACH THE TARP BOARD TO THE TOP OF THE CORNER POSTS WITH 2-1/2" WOOD SCREWS.
- 6: REPEAT SUBSTEPS 4 AND 5 TO INSTALL THE LAST TARP BOARD.

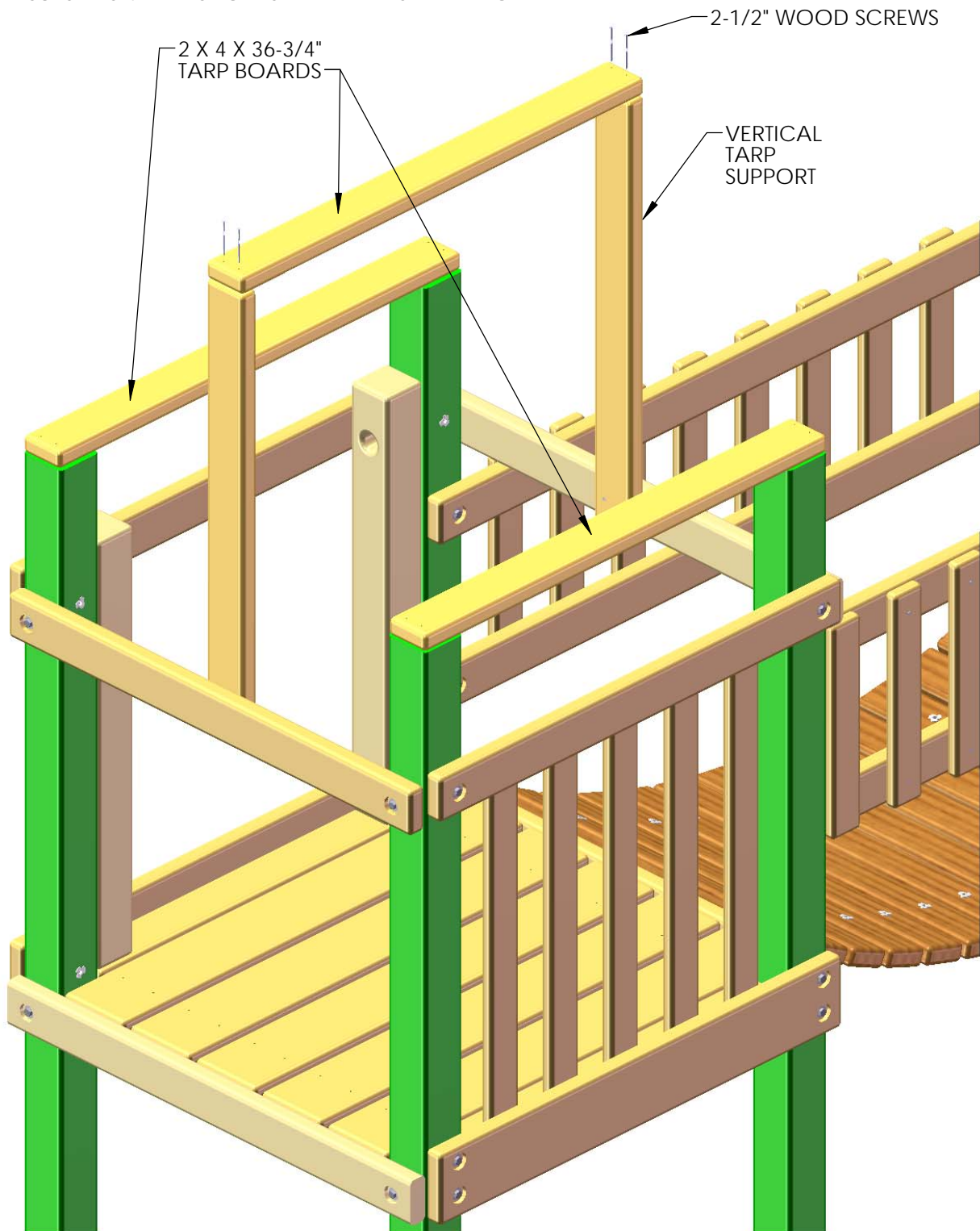

STEP 24: CLATTER BRIDGE TARP

- 1: LOCATE THE 34-1/4" X 57-1/2" CLATTER BRIDGE TARP.
- 2: PLACE THE TARP OVER THE TOP OF THE TARP BOARD ON TOP OF THE VERTICAL TARP SUPPORTS.
- 3: THE TARP WILL OVERLAP THE SIDE OF THE TARP BOARDS ON TOP OF THE CORNER POSTS.
- 4: ATTACH THE TARP THROUGH THE GROMMETS TO THE TARP BOARDS WITH #14 X 1-1/4" PAN HEAD SCREWS AND 1/4" FLAT WASHERS.

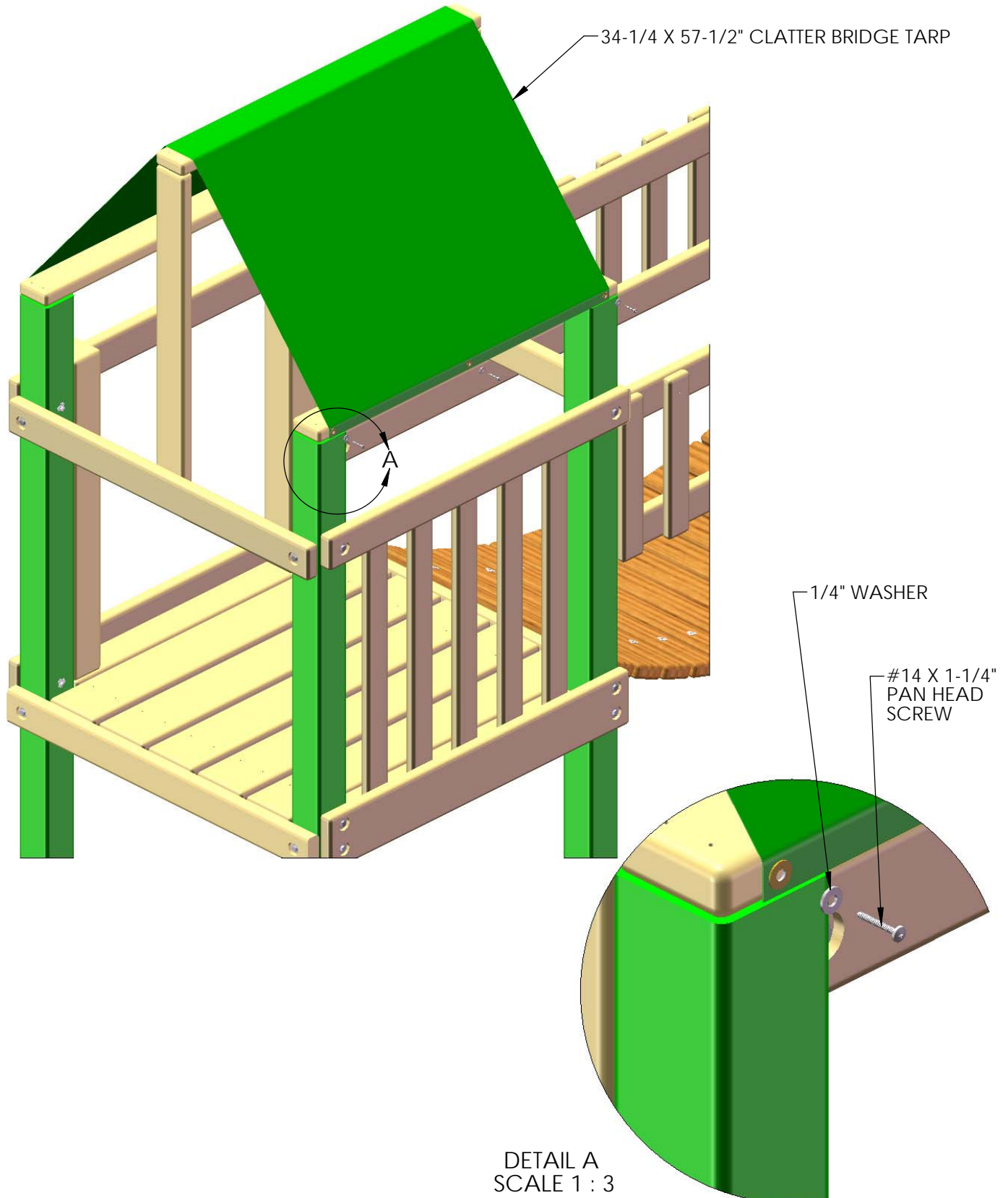

STEP 25: BOARD REMOVAL

1: REMOVE THE 2 X 4 AT THE TOP LEFT AS SHOWN BELOW.

2: REMOVE THE 2 X 6 AT THE MIDDLE LEFT AS SHOWN BELOW.

3: USE A 5/16" X 3-1/2" HEX BOLT AND A 5/16" WASHER TO FILL THE FOUR HOLES WHERE THE 2 X 4 AND 2 X 6 WERE ATTACHED.

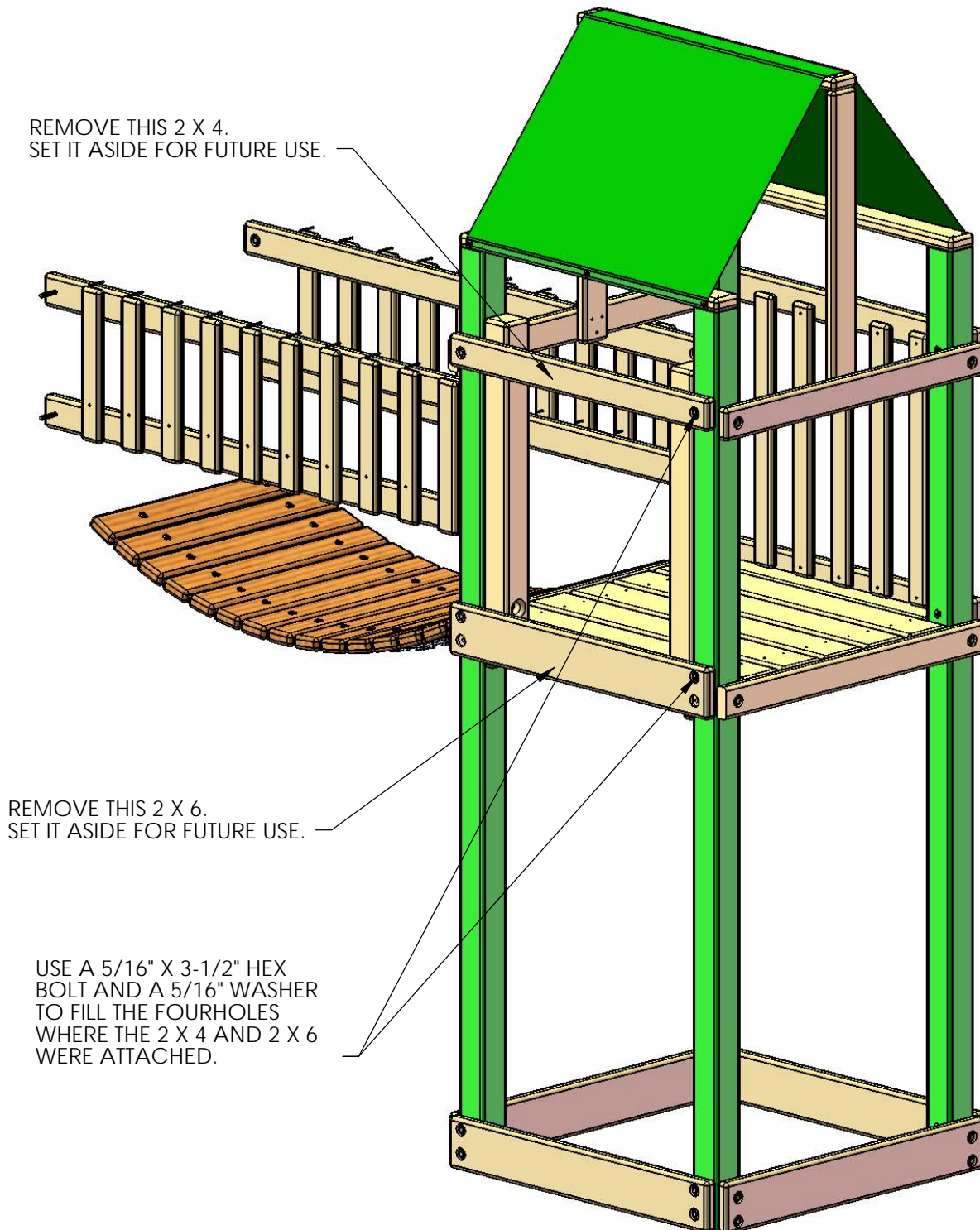

STEP 26: DRILLING RADICAL RIDE ENTRY PLATE

- 1: LOCATE THE RADICAL RIDE ENTRY PLATE IN THE RADICAL RIDE SLIDE BOX.
- 2: DRILL FOUR HOLES WHERE INDICATED BELOW WITH A 3/8" DRILL BIT.
- 3: THE BOTTOM TWO MOUNTING HOLES SHOWN BELOW ARE NOT USED WHEN MOUNTING THE FACE PLATE TO THE LAG POSTS.

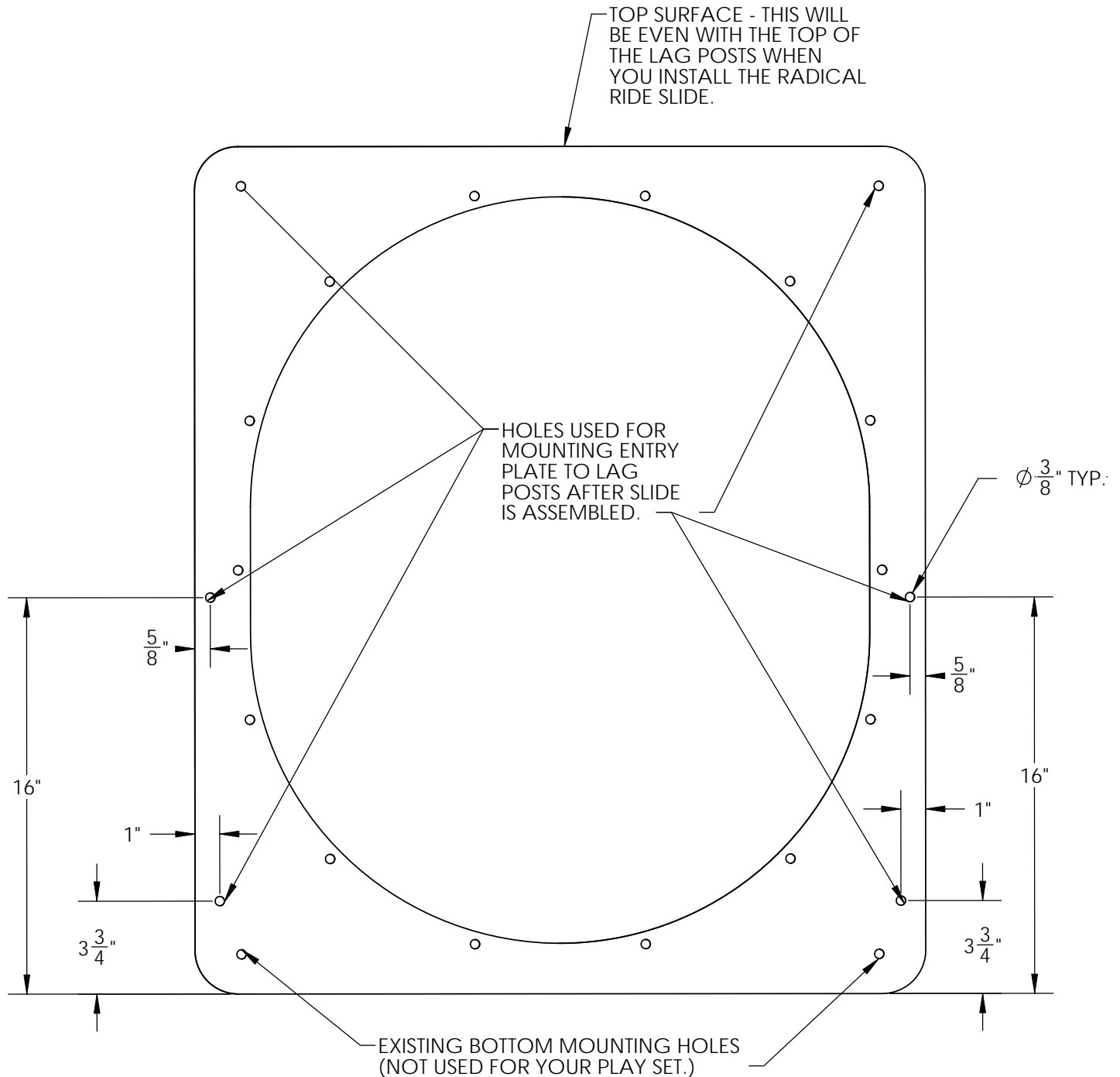

STEP 27: ATTACHING RADICAL RIDE SLIDE

1: ASSEMBLE THE RADICAL RIDE 5 TUBE SLIDE FOLLOWING THE DIRECTIONS THAT CAME WITH THE SLIDE. WHEN YOU GET TO STEP 3 IN THE RADICAL RIDE 5 INSTRUCTIONS ****STOP**** AND USE THIS STEP INSTEAD TO MOUNT THE ENTRY PLATE AND ENTRY ASSEMBLY TO THE CLATTER BRIDGE TOWER.

2: ATTACH THE ENTRY PLATE AND ENTRY SECTIONS TOGETHER AT THE MIDDLE HOLE AS SHOWN BELOW ON EACH SIDE. USE A 5/16" X 3/4" HEX BOLT, TWO 5/16" WASHERS AND A LOCK NUT FOR THIS.

3: ALIGN THE TOP OF THE ENTRY PLATE WITH THE TOP OF THE 4 X 4 LAG POSTS INSTALLED EARLIER.

4: ATTACH ENTRY PLATE TO THE LAG POSTS WITH 5/16" X 3-1/2" LAG SCREWS AND 5/16" WASHERS AS SHOWN BELOW. DO NOT USE THE BOTTOM HOLE IN THE ENTRY PLATE. ONLY USE THE TOP HOLES AND THE FOUR HOLES YOU DRILLED IN STEP 26.

YOU MAY HAVE NOTICED THAT BOLT HEADS OR NUTS ARE SANDWICHED BETWEEN THE ENTRY PLATE AND THE LAG POSTS. THIS IS NORMAL.

5: FOLLOW THE REMAINING STEPS IN THE RADICAL RIDE 5 TUBE SLIDE INSTRUCTIONS TO COMPLETE THE SLIDE ASSEMBLY.

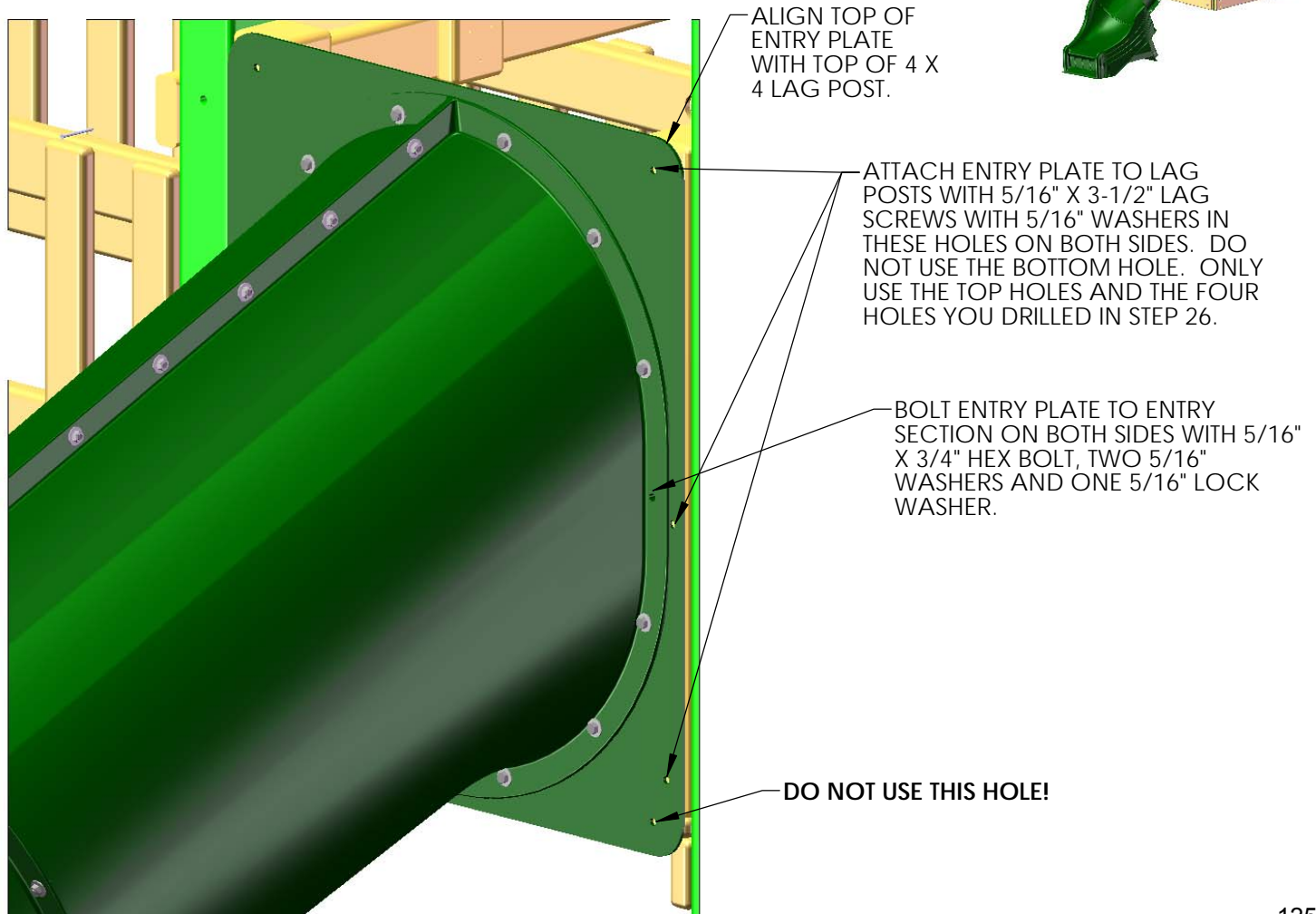
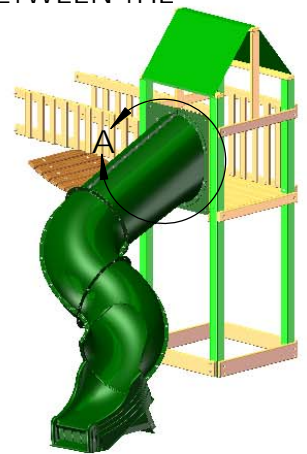

STEP 28: ATTACHING 2 X 4 AND 2 X 6 PANEL BOARDS

1: LOCATE THE 2 X 4 X 36-3/4" TOP PANEL BOARD AND THE 2 X 6 X 36-3/4" BOTTOM PANEL BOARD THAT YOU REMOVED IN STEP 25.

2: PLACE THE BOTTOM OF THE 2 X 4 FLUSH TO THE TOP OF THE ENTRY PLATE. ATTACH THE 2 X 4 TO THE CORNER POSTS WITH 5/16" X 3-1/2" LAG SCREWS AND 5/16" WASHERS.

3: PLACE THE TOP OF THE 2 X 6 OFFSET UP AGAINST THE BOTTOM OF THE ENTRY PLATE. ATTACH THE 2 X 6 TO THE CORNER POSTS WITH 5/16" X 3-1/2" LAG SCREWS AND 5/16" WASHERS.

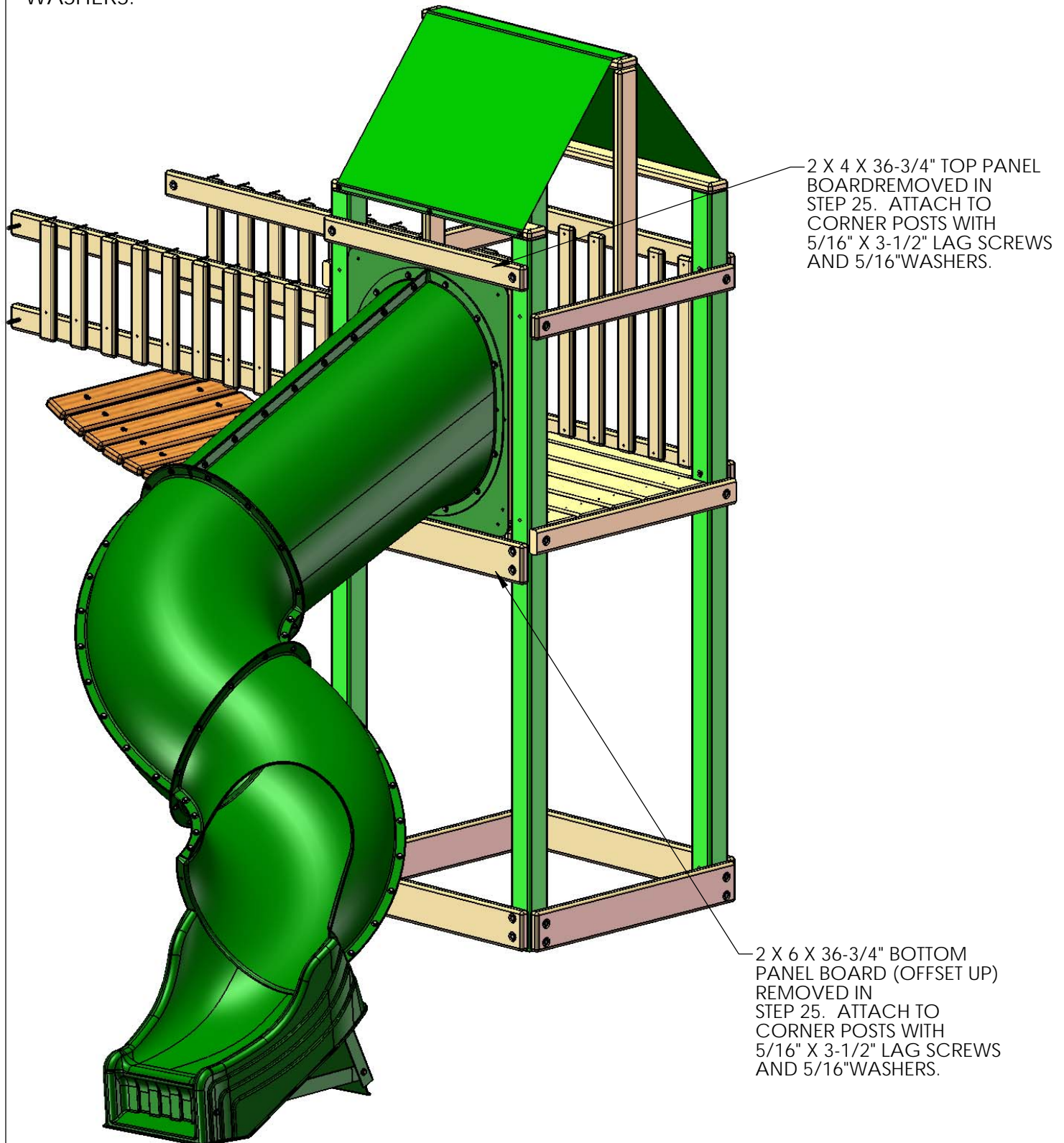

STEP 29: ATTACHING WAVE SLIDE

1: PLACE THE SLIDE IN THE OPENING OF THE CLATTER BRIDGE TOWER AS SHOWN WITH THE LIP OF THE SLIDE RESTING ON TOP OF THE DECK BOARDS.

2: ATTACH THE SLIDE TO THE DECK BOARDS WITH FOUR #14 X 1-1/4" PAN HEAD SCREWS
DO NOT OVER TIGHTEN

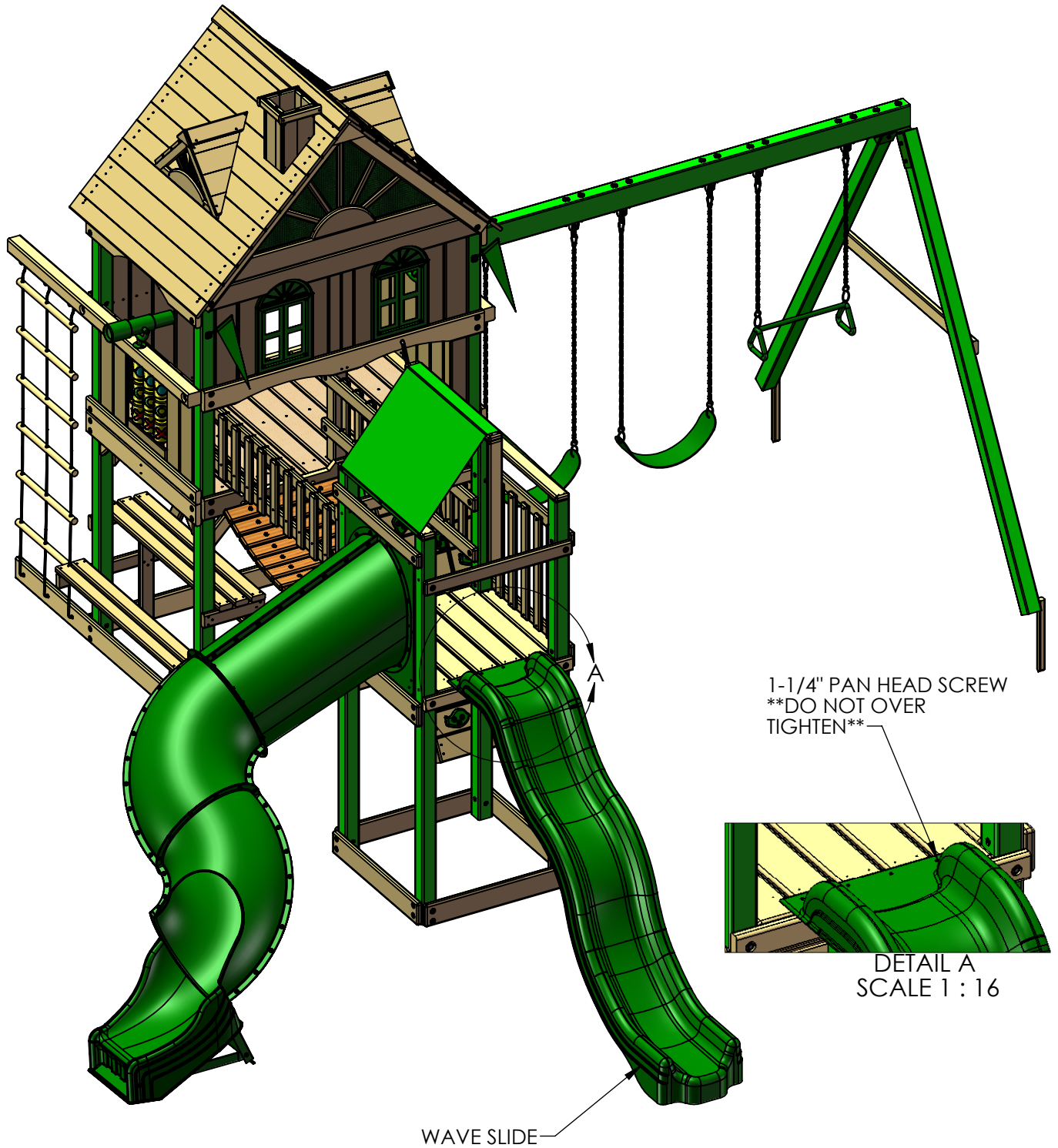

STEP 30: FINAL PANEL SLAT

1: LOCATE THE 5/4 X 2-5/8" X 25" PANEL SLAT.

2: THIS SLAT WILL GO INSIDE THE PLAY SET ON TOP OF THE DECK ON THE LEFT HAND SIDE. IT WILL BE FLUSH AGAINST THE BRIDGE RAILS AS SHOWN IN DETAIL A BELOW.

3: ATTACH THE PANEL SLAT TO THE INSIDE OF THE 2 X 6 X 70 FRONT FACE BOARD AND INSIDE OF THE 2 X 6 X 70 TOP PANEL BOARD WITH TWO 2" WOOD SCREWS.

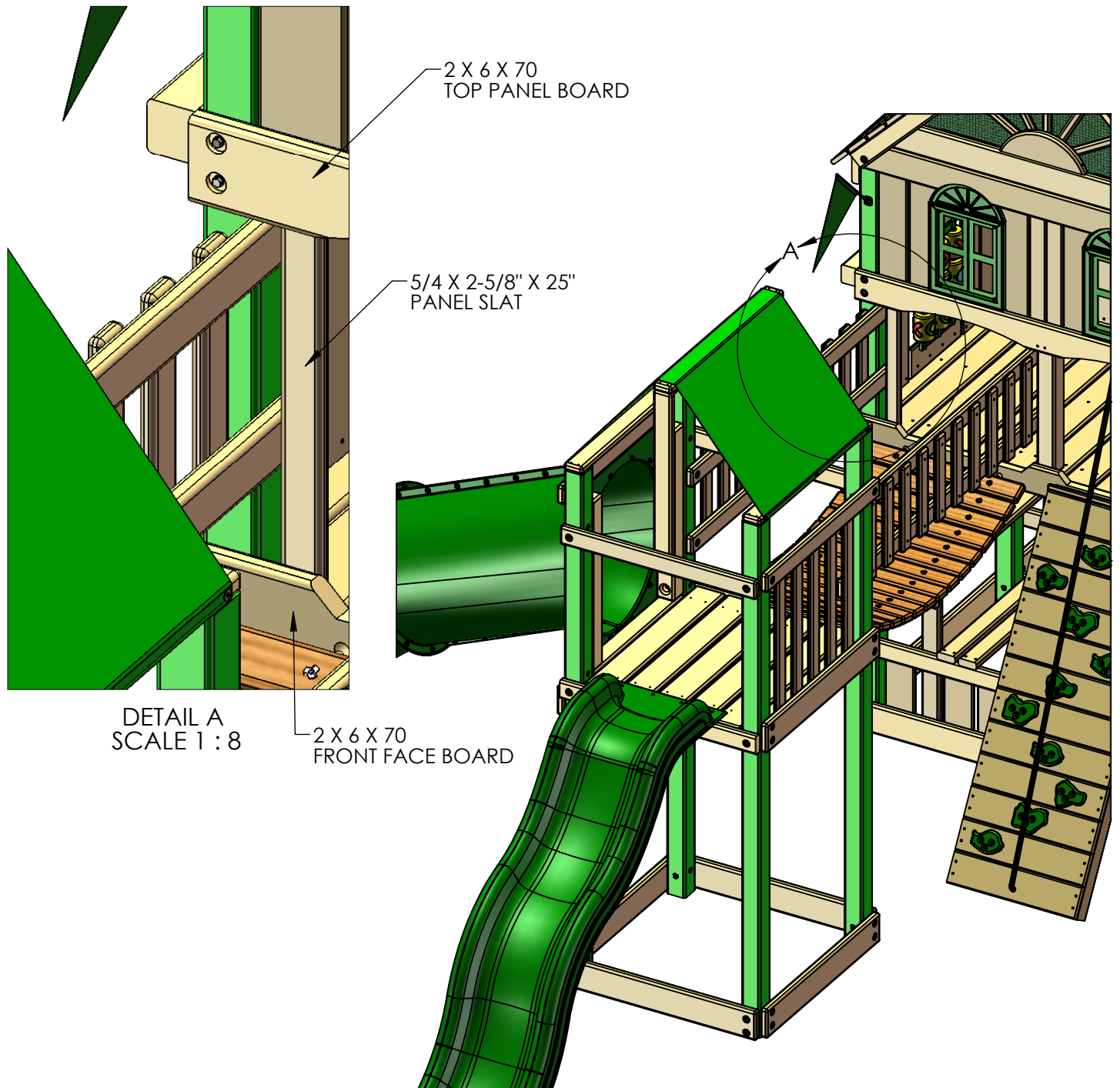

STEP 31: NAME PLATE

1: ATTACH THE Gorilla NAME PLATE CENTERED ON THE FRONT OF YOUR SWING BEAM WITH TWO 2-1/2" WOOD SCREWS.

2: YOUR PLAYSET IS FINISHED! ENJOY YOUR PLAYSET!



WARRANTY REGISTRATION

- WOODBRIDGE -

Gorilla Playsets manufactures the finest quality products that are designed for outstanding strength and durability. We back our products with an unparalleled warranty. In the unlikely event that you will need to contact us about covered repairs, we must have a valid Warranty Registration on file.

3 EASY WAYS TO REGISTER	
OPTION 1	<div style="display: flex; justify-content: space-between;"> <div style="width: 45%;"> Fax this completed form to: (678) 880-3329 </div> <div style="width: 10%; text-align: center; font-size: 24px; font-weight: bold;">OR</div> <div style="width: 45%;"> Mail this completed form to: Gorilla Playsets 190 Etowah Industrial Court Canton, GA 30114 </div> </div>
OPTION 2	Complete the online registration form at: http://www.gorillaplaysets.com/register
OPTION 3	<div style="display: flex; justify-content: space-between;"> <div style="width: 60%;"> Scan this QR Code with your smart phone to complete the form using your phone </div> <div style="width: 35%; text-align: center;">  </div> </div>

Where did you buy this product?:

Date of Purchase _____ Place of Purchase _____

Your registration information:

Name: _____ Email: _____

Address: _____

Street City State Zip

Please select your age? <input type="checkbox"/> 18-30 <input type="checkbox"/> 31-40 <input type="checkbox"/> 41-50 <input type="checkbox"/> 51+		How would you rate the quality of this product?	<input type="checkbox"/> ★★★★★ Excellent <input type="checkbox"/> ★★★★ Above Average <input type="checkbox"/> ★★★ Average <input type="checkbox"/> ★★ Below Average <input type="checkbox"/> ★ Poor
How old are your children? <input type="checkbox"/> 2-3 <input type="checkbox"/> 4-5 <input type="checkbox"/> 6-7 <input type="checkbox"/> 8+			

Would you recommend this product to friends & family? Yes No

Comments: _____
