

# gorilla<sup>®</sup>

playsets



## Treasure Trove™

ASSEMBLY MANUAL  
Copyright © 2012 Gorilla Playsets  
All Rights Reserved

Gorilla Playsets • 190 Etowah Industrial Court Canton, GA 30114  
(800) 882-0272 • [www.gorillaplaysets.com](http://www.gorillaplaysets.com)  
Latest Revision: March 23, 2012

# TABLE OF CONTENTS

Warranty and Safety Guidelines.....	Pages 3-10
Leveling Playset, General Information, Definitions and Site Plan.....	Pages 10-15
Tool List and Kit Contents.....	Page 10
Hardware, Lumber and Accessory Checklist.....	Pages 17-34
Framing the play set.....	Steps 1-9
Constructing deck and lower deck supports.....	Steps 10-12
Constructing and attaching ladder.....	Steps 13-14
Attaching angle braces.....	Steps 15-16
Constructing rock wall and attaching to play set.....	Steps 17-21
Installing upper level steps and lower level center posts.....	Steps 22-25
Attaching picnic table supports, table, benches and stringer.....	Steps 26-28
Installing panel slats.....	Steps 29
Assembling swing beam and attaching to play set.....	Steps 30-36
Framing upper level.....	Steps 37-46
Constructing upper deck.....	Steps 47-50
Installing upper level panel slats.....	Step 51
Assembling upper level roof.....	Steps 52-61
Assembling lower level roof.....	Step 62-68
Attaching upper level angle supports.....	Steps 69-70
Safety Handles, Telescope, Periscope and Steering Wheel.....	Steps 71-74
Sandbox Cover and Rock Wall Rope.....	Steps 75-76
Rope Ladder assembly and installation.....	Steps 77-78
Tic Tac Toe Panel.....	Step 79
Attaching Radical Ride Tube Slide to playset.....	Step 80

# TABLE OF CONTENTS

Chimney and Dormer Installation.....	Step 81
Glider Swing Assembly.....	Step 82
Hanging Swings.....	Step 83
Installing Flag Kit.....	Step 84
PART II Clatterbridge Assembly.....	Page 120
Hardware, Lumber and Accessory checklist.....	Pages 121-123
Framing Clatterbridge.....	Steps 1-8
Clatterbridge Tower Deck.....	Steps 9-11
Rear Bottom Panel Board and Panel Slats.....	Steps 12-13
Constructing Bridge Rails and attaching to tower and play set.....	Steps 14-16
Constructing clatterbridge deck with chains.....	Steps 17-19
Attaching clatterbridge deck/chains to tower.....	Step 20
Drilling holes for chains in fort (play set).....	Steps 21-21A
Attaching clatterbridge deck/chains to play set.....	Step 22
Tarp framing and Tarp installation.....	Steps 23-25
Attaching Wave Slide.....	Step 26
Attaching Telescope.....	Step 27
Attaching Name Plate.....	Step 28
Customer Warranty Registration Card.....	Last Page

**PLEASE READ OWNER'S MANUAL CAREFULLY  
BEFORE STARTING ASSEMBLY!**

# IMPORTANT – PLEASE READ

As fresh lumber acclimates to its new environment, the natural tendencies of the tree can show itself in the form of checks, or “cracks” in the lumber. In almost all cases this is normal and it will not affect the structural integrity of your play set.

Cosmetic defects that do not affect the structural integrity of the product, or natural defects of wood such as warping, checking or any other physical properties of wood that do not present a safety hazard, are not covered by this warranty. Defects that develop because the product is exposed to extreme climate conditions are not covered by this warranty. Defects that develop as a result of faulty or improper installation of the product are also not covered by this warranty.

Most cracks are not warrantable, however if you believe that the integrity of your play set is compromised by this natural occurrence, please follow the warranty claim procedure found at [www.gorillaplaysets.com](http://www.gorillaplaysets.com). Click on the “Customer Care” tab on the left hand side of the page, then click on “Warranty Claim” and follow the instructions.

We appreciate your purchase and know that you will enjoy your play system for many years to come.

IF YOU HAVE MISSING OR DAMAGED PARTS OR NEED ASSISTANCE ASSEMBLING, PLEASE CALL Gorilla Playsets™ MANUFACTURING DIRECT. (800) 882-0272 FACTORY HOURS – MON.–FRI., 8AM-5PM EST DO NOT RETURN THIS PRODUCT TO THE RETAILER OR CONTACT THE RETAILER DIRECT. THE RETAILER DOES NOT STOCK COMPONENTS. PLEASE RETAIN THESE INSTRUCTIONS FOR FUTURE REFERENCE. KEEP THEM IN A SAFE PLACE WHERE YOU CAN REFER TO THEM AS NEEDED.

## CONTACT INFO:

Gorilla Playsets  
190 Etowah Industrial Court  
Canton, GA 30114  
Tel. (800) 882-0272  
Fax. (678) 880-3329  
[custsrv@gorillaplaysets.com](mailto:custsrv@gorillaplaysets.com)

Check for revised instructions at [www.gorillaplaysets.com/category-s/92.htm](http://www.gorillaplaysets.com/category-s/92.htm)

# Thank you for choosing Gorilla Playsets®

We've included everything you need, except tools, to build your very own professional looking play set. When complete, your new play set should far exceed the quality of play set kits from other build-your-own companies. Our engineers and design team have over 30 years of playground experience. What we've developed is a play set that doesn't compromise quality for simplicity. Yet you'll appreciate how quick and easy construction really is! Our play set kits are designed for children ages 3 to 11. Gorilla Playsets® believes every child should have a play set and with our kits they can! You can rest assured your new play set is safe, durable and designed to hold up to the elements. As parents ourselves, we know how important the security and well-being of our children is, and this shows in all of our products.

Each play set features our step-by-step 3D illustrated manual, patented powder coated swing beam bracket, heavy-duty swing belts with chains, slide(s), accessories, plus all the required hardware and pre-milled lumber.

## Quality Lumber

At Gorilla Playsets, we use only the finest, hand selected lumber available. You can be assured that our lumber is strong, durable, and conforms to the national standards for use in children's play equipment. It's this quality that allows us to offer a 10 year warranty on the lumber used in our play sets.

# Limited Manufacturers Warranty

Gorilla Playsets® (“Gorilla”) warrants its play sets to be free from defects in workmanship and materials, under normal use and conditions at its original installation, for 10 years for structural wood components and for one year for all other components (e.g., hardware, plastics, tarps, rope ladder, etc.).

Cosmetic defects or natural defects of wood (e.g., warping, seasonal checking or cracking, knots, or knot holes, etc.) that do not affect the structural integrity of the product are not covered by this warranty. Defects that develop because the product is exposed to extreme climate conditions, excessive water exposure, lumber that has been damaged by wood boring bees, or defects that develop as a result of faulty or improper installation of the product, are not covered by this warranty. Fading, discoloration, or molding of any wood part or accessory, cracks in plastic components, surface rust on hardware, and chips on powder coated materials are not considered defects in material as long as they do not affect the functionality or structural integrity of the part or component.

It is the owner’s responsibility to properly maintain the play set. Instructions for proper maintenance can be found on Gorilla’s website. Imperfections or defects that develop because of a failure to properly maintain the play set are not covered by this warranty.

Gorilla will repair or, at its discretion, replace any part within the stated warranty period that is defective in workmanship or materials. This decision is subject to verification of the defect, which, at Gorilla’s discretion, may be accomplished by submitting photographs or by delivery of the defective part to Gorilla. Any warranty claim must include proof of purchase, including the date of purchase. In addition, within the first 30 days from the date of purchase, Gorilla will replace any parts discovered to be missing from or damaged in the original packaging.

This warranty is valid only if the product is used for the purpose for which it was designed and installed at a residential, single-family dwelling. This warranty is void if the product is used in a commercial or institutional setting. This warranty does not cover (a) products that have been damaged by acts of God, negligence, misuse, or accident, or that have been modified or repaired by unauthorized persons; (b) the cost of labor; or (c) the cost of shipping the product, any part, or any replacement product or part.

GORILLA DISCLAIMS ALL OTHER REPRESENTATIONS AND WARRANTIES OF ANY KIND, EXPRESS, IMPLIED, STATUTORY, OR OTHERWISE, INCLUDING THE IMPLIED WARRANTIES OF MERCHANTABILITY AND FITNESS FOR A PARTICULAR PURPOSE. GORILLA WILL NOT BE LIABLE FOR ANY INCIDENTAL OR CONSEQUENTIAL DAMAGES. This warranty is valid only in the United States of America, is nontransferable and does not extend to the owners of the product subsequent to the original purchaser. Some states do not allow limitations on implied warranties or exclusion of incidental or consequential damages, so these restrictions may not be applicable to you. This warranty gives you specific legal rights. You may also have other rights which vary from state to state.

# IMPORTANT SAFETY GUIDELINES

This product is intended for residential use only and not intended for use in any public setting. A safety surface such as mulch or recycled tire should be used under the play set to prevent injury from falls. Also a 6 foot safety zone should be used around the entire play set.

As with any home project, good judgment and respect for power tools will greatly reduce the risk of injury. Gorilla recommends you follow all tool manufacturers' safety guidelines. Always wear eye protection and safety gloves to prevent injury. In several phases of construction two people may be required for lifting and securing of lumber. While play set is being constructed, please keep children off the equipment until the project is complete. Bolts and screw heads should be checked regularly for tightness. The ground ladder, rope ladder, slide, swings and other areas where children spend a majority of their playtime should be checked more frequently.

Gorilla shall not be liable for incidental, indirect or consequential damages or injuries that result from the building and/or playing on our play sets. Adult supervision is recommended anytime a play set is being used.

## WEIGHT LIMITS FOR GORILLA PLAYSETS

- FORT PLATFORMS: 800 LBS. TOTAL WEIGHT
- SWING BELTS: 225 LBS.
- GLIDER SWINGS: 70 LBS. PER CHILD. UP TO 140 LBS TOTAL.
- TRAPEZE: 125 LBS.
- FULL BUCKET SWING: 50 LBS.
- HALF BUCKET SWING: 50 LBS.
- INFANT SWING: 35 LBS.
- TIRE SWING: 125 LBS. TOTAL WEIGHT
- ROPE LADDER: 75 LBS.
- ROCK WALL: 150 LBS.
- WAVE SLIDE: 150 LBS.
- RADICAL RIDE TUBE SLIDE: 150 LBS.
- CLATTER BRIDGE: 250 LBS.

Gorilla recommends that the weight limits for all components must not be exceeded. Failure to adhere to these and other safety guidelines could result in damage to the play set and injury to the users.

# Safety and Maintenance Tips for Your New Play Set:

**NOTE: Your children's safety is our #1 concern. Observing the following statements and warnings reduces the likelihood of serious or fatal injury. Please review these safety rules regularly with your children.**

- This play set is designed for the use of 4 occupants who have a combined weight not exceeding 800 pounds on the elevated floor, 3 occupants who have a combined weight of 525 pounds on the swing area, for a total Unit capacity of 7 occupants who have a combined weight of 1325. (this weight is not including the picnic table area)
- On-site adult supervision is required.
- Teach children not to walk close to, in front of, behind, or between moving swings or other moving playground equipment.
- Teach children to sit in and never stand on swings
- Teach children not to twist the chains and ropes and not to loop them over the swing beam, since this may reduce the strength of the chain or rope.
- Teach children not to jump from swings or other playground equipment in motion.
- Teach children not to push empty seats. The seat may hit them and cause serious injury.
- Teach children to sit in the center of the swings with their full weight on the seats.
- Teach children not to use the equipment in a manner other than intended.
- Teach children to always go down slides feet first. Never slide headfirst.
- Teach children to look before they slide to make sure no one is at the bottom.
- Teach children to never run up a slide, as this increases their chances of falling.
- Parents should have children dress appropriately with well-fitting shoes. Loose clothing such as scarves and ponchos should not be worn. Always take off, tie up or tuck in cords and drawstrings on children's clothing. These things can get caught on playground equipment and strangle a child.
- Teach children not to climb when the equipment is wet.
- Teach children to never jump from a fort deck. They should always use the ladder, ramp or slide.
- Teach children to never crawl or walk across the top of monkey bars.
- Teach children to never crawl on top of a fort roof.
- Verify that any suspended climbing ropes, chains, or cables are secured at both ends and that they cannot be looped around an adult hand.
- Teach children not to attach items to the playground equipment that are not specifically designed for use with the equipment, such as, but not limited to, jump ropes, clothesline, pet leashes, cables and chain as they may cause a strangulation hazard.
- Teach children to never wrap their legs around swing chain.
- Teach children to never slide down the swing chain.

**WARNING: Children must NOT use this play set until unit has been completely assembled and inspected by an adult to insure set has been properly installed.**



# **Safety and Maintenance Tips for Your New Play Set: (continued)**

Playgrounds should be inspected on a regular basis. If any of the following conditions are noted, they should be removed, corrected, or repaired immediately to prevent injuries.

- Hardware that is loose, worn or that has protrusions or projections.
- Exposed equipment footings.
- Scattered debris, litter, rocks, or tree roots.
- Splinters, large cracks, and decayed wood components.
- Deterioration and corrosion on structural components, which connect to the ground
- Missing or damaged equipment components, such as handholds, guardrails, swing seats.
- Check all nuts and bolts frequently during the usage season and tighten as required. (But not so tight that you crack the wood) We recommend you check the swing beam and hardware often due to wood expansion and contraction. It is particularly important that this procedure be followed at the beginning of each season.
- Remove plastic swing seats and take indoors or do not use when the temperature drops below 32°F.
- Oil all metallic moving parts monthly during the usage period.
- Check all coverings for bolts and sharp edges twice monthly during usage season to be certain they are in place. Replace when necessary. It is especially important to do this at the beginning of each new season.
- Check swing seats, ropes, cables and chains monthly during usage season for evidence of deterioration. Replacement should be made of any swing seat that has developed cracks in the plastic seats. Ropes, cables and chains should be removed and replaced if excessive wear is found. Contact Gorilla for warranted replacement parts.
- For rusted areas on metallic members such as monkey bars, hand supports brackets, etc.; sand and repaint, using a non lead-based paint meeting the requirements of Title 16 CRF Part 1303.
- Inspect wood parts monthly. The grain of the wood sometimes will lift in the dry season causing splinters to appear. Light sanding may be necessary to maintain a safe playing environment. If you are treating your play set with stain regularly, it will help prevent severe checking/splitting and other weather damage.
- Once or twice a year, depending on your climate conditions, you must apply some type of protection (sealant) to the wood of your unit. Prior to the application of sealant, lightly sand any “rough” spots on your set. Please note this is a requirement of your warranty.
- Creating and maintaining the play set on a level location is very important. As your children play, your play set will slowly dig its way into the soil, and it is very important that it settles evenly. Make sure the play set is level and true once each year or at the beginning of each play season.
- Rake the play ground surface periodically to prevent compaction and maintain appropriate depths.
- Disposal Instructions: When the play set is no longer desired, it should be disassembled and disposed of in such away that no unreasonable hazards will exist at the time the unit is discarded.

# Play Set Surfacing Recommendations:

Below are some of the recommendations that the U.S. Consumer Product Safety Commission (CPSC) offers from its Handbook for Public Playground Safety. The guide can be downloaded in full at [www.cpsc.gov/cpscpub/pubs/325.pdf](http://www.cpsc.gov/cpscpub/pubs/325.pdf)

**1. Protective Surfacing** - Since almost 60% of all injuries are caused by falls to the ground, protective surfacing under and around all playground equipment is the most critical safety factor on playgrounds.

Certain manufactured synthetic surfaces also are acceptable; however, test data on shock absorbing performance should be requested from the manufacturer.

Asphalt and concrete are unacceptable. They do not have any shock absorbing properties. Similarly, grass and turf should not be used. Their ability to absorb shock during a fall can be reduced considerably through wear and environmental conditions.

Certain loose-fill surfacing materials are acceptable. Surfacing materials are acceptable, such as the types and depths shown in the table.

## Fall Heights and Materials

Type Of Material	6 in. depth	9 in. depth	12 in. depth
Double-Shredded bark mulch	6' Fall Height	10' Fall Height	11' Fall Height
Wood Chips	6' Fall Height	7' Fall Height	12' Fall Height
Fine Sand	5' Fall Height	5' Fall Height	9' Fall Height
Shredded Tires*	10-12' Fall Height	N/A	N/A
Fine Gravel	6' Fall Height	7' Fall Height	10' Fall Height

\*This data is from tests conducted by independent testing laboratories on a 6-inch depth of uncompressed shredded tire samples produced by four manufacturers. The tests reported critical heights, which varied from 10 feet to greater than 12 feet. It is recommended that persons seeking to install shredded tires as a protective surface request test data from the supplier showing the critical height of the material when it was tested in accordance with ASTM F1292.

*It should be recognized that all injuries due to falls cannot be prevented no matter what surfacing material is used.*

**2. Fall Zones** - A fall zone, covered with a protective surfacing material, is essential under and around equipment where a child might fall. This area should be free of other equipment and obstacles onto which a child might fall. Stationary climbing equipment and slides should have a fall zone extending a Minimum of 6' in all directions from the perimeter of the equipment.

Swings should have a fall zone extending a minimum of 6' from the outer edge of the support structure on each side. The fall zone in front and back of the swing should extend out a minimum distance of twice the height of the swing as measured from the ground to the top of the swing support structure.

## LEVELING YOUR FORT DURING ASSEMBLY

- Complete the steps which will be the basic frame of the fort {i.e. four corner posts with base (sand box boards) and deck supports}
- Position in the most level area chosen for the play set, keeping in mind the location and size of the swing beam, ladder, slides, etc. that extend off the fort.
- Once the frame is in the final position, check for vertical and horizontal levelness to determine which side(s) will need to be dug into the ground to level the play set.
- With a shovel, score the ground around the outside edges of the sandbox boards on the 'high' side of the fort. This is the area that will be dug in. Make sure to score deep enough; the scored lines will be your digging template.
- Push the frame off and away from the scored area, far enough to dig and remove dirt to reach the appropriate depth.
- Dig a channel along the scored line(s) for the base of the fort (corner post and sandbox boards) to rest into. Dig the channel(s) to the same level depth. The bottom of the channel(s) should be level to each other so your frame doesn't teeter or rock because the channel(s) are uneven.
- Once you have removed enough grass and dirt, slide/push the frame into the channel(s). Place a level on the vertical and horizontal boards of the frame to determine if enough soil, or too much, was removed.
- Repeat this process until the basic frame is plumb and level and in its final position before completing the rest of the assembly.
- Measure to make sure fort is square.

**Important: if you require a channel depth of more than 6", then we recommend you have your play set area professionally graded before completing assembly.**

*Example Play area:*

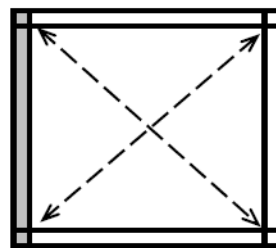
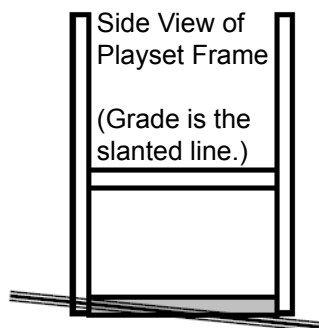

The diagonal measurements should be the same from corner post to corner post. If not, adjust corner posts so that the distance is equal.

■ = Area to be scored and channeled for levelness

# General Info to Review Before Installation

- Depending on your experience, assembly of Gorilla Playsets can take as little as 6 hours up to 24 hours, depending on size, after inventory of parts; therefore, we recommend you set aside a full two days for assembly.
- Identify all of the parts for your play set. Empty each box and lay out boards so you can see each part. Your instruction book will have detailed drawings that will make it easy for you to recognize individual parts. Keep all hardware and metal parts separate from wooden pieces.
- After everything is laid out, check carefully to ensure all parts are present. Make sure there are no broken boards.
- Find an area to sort your hardware. It is best to open the hardware on a solid surface so that you do not lose any pieces in the grass. This will save time and familiarize you with all the different pieces in the hardware bag.
- Important note: Wood has some natural defects such as knots, surface cracks, etc... We reject parts that are structurally defective. We use a high quality lumber in our structures; however, you should inspect each part for splinters or rough spots and sand them smooth to prevent injury.
- After familiarizing yourself with all of the components, read all instructions thoroughly. Reading instructions after you have studied the parts will help you understand more clearly the installation process, and help to eliminate unnecessary mistakes.
- Pay close attention to the diameter and length of each bolt and screw.
- Never tighten hardware completely at first. It helps to have some adjustment for bolt alignment while you are attaching parts together. After everything is square, tighten each joint.
- After the main unit is assembled it is critical that the floor is level and square. If the main frame is not level, the walls and floor will be out of square.
- After you complete installation, make sure every bolt, screw, and nut is tight, and every board is secure. Wood will expand and contract with the seasons.
- Check all bolt connections and swing hangers every two weeks.
- Place the set on level ground, not less than 6ft from any structure or obstruction such as a fence, garage, house, overhanging branches, laundry lines, or electrical wires.

**This page is a list of definitions and explanations used throughout our instructions to aid you in the assembly of your play set.**

**Offset Holes-** Throughout the installation procedures we will refer to parts with offset holes. This refers to the orientation of the holes on the board. An offset hole is one that is closer to one side than it is the other or in other words, it is not centered on the board. In the procedures you will be instructed to attach the boards with the holes offset up or with the holes offset down. This refers to which side of the board the hole/holes should be closer to. Offset holes up= hole/holes will be closer to the top of the board. Offset holes down= hole/holes will be closer to the bottom of the board. Note: some parts do not have offset holes, but instead the holes are on center. Therefore there will not be any reference to how to offset these parts.

### **EXAMPLE OF OFFSET HOLES UP**



### **EXAMPLE OF OFFSET HOLES DOWN**



**Counterbored holes-** Many of the parts that will be used have counterbored holes. A counterbored hole is one that surrounds one side of a thru hole, but does not extend through the wood it's self. When using a counterbored hole the bolt will be inserted through the thru hole and either the head of the bolt and washer or nut and washer will occupy the counterbored hole.

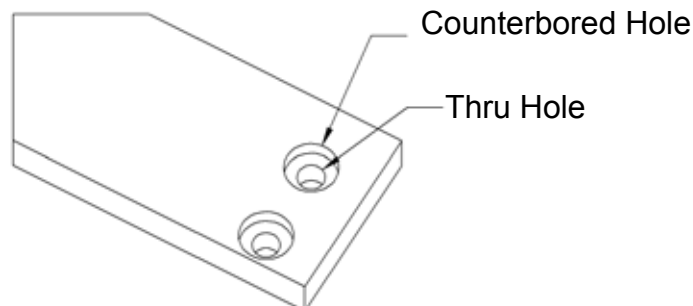

**Lag Screws-** Lag screws are used in the construction of our play sets to enhance the structural integrity of the unit. There will not be predrilled holes in the post for lag screw installation. Lag screws are self-tapping, though if you are using a manual socket wrench it may be necessary to tap the head of the lag screw with a hammer. You should also be sure to tighten the lags completely. Power tools such as an impact wrench or power drill should have enough torque to drive the lag screws without using a hammer, but make sure not to over tighten as this can cause the threads to “strip out” in the post.

# Common Installation Practice Installing T-nuts

When installing T-nuts into the wood, use a smooth faced hammer to set the face of the T-nut flush into the wood

Corner Post

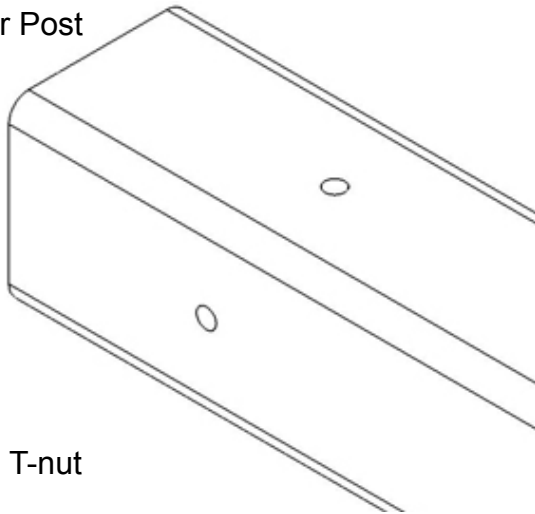

T-nut

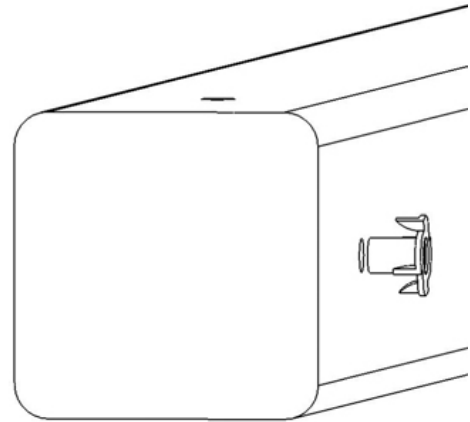

Insert the barrel of the T-nut into the predrilled hole. Using a smooth faced hammer, drive the T-nut until the face of the T-nut is flush to the wood.

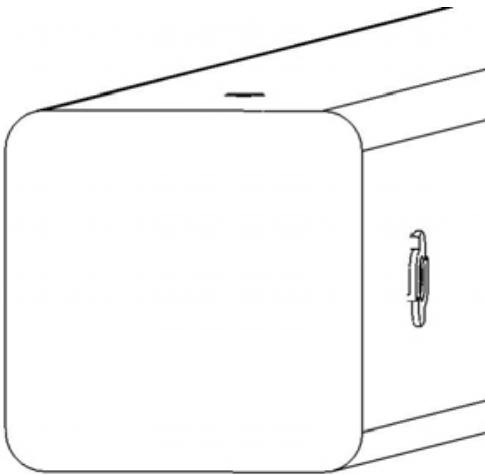

This picture shows the T-nut insert and installed flush to the wood.

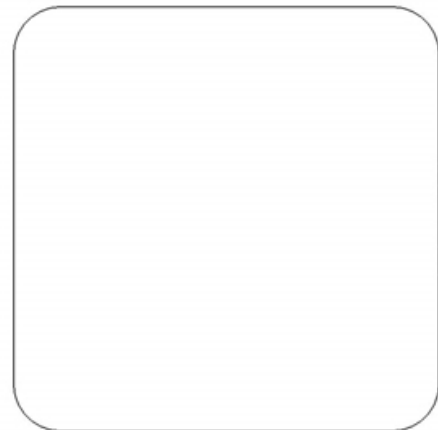

This picture shows an end view of the T-nut insert and installed flush to the wood.

**WARNING: DO NOT EMBED THE TOP OF THE T-NUT INTO THE FACE OF THE WOOD**

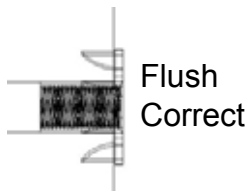

Cross Section end views, you are looking at an Xray view of the post and T-nut. The barrel of the T-nut is in the corner post the line is the face of the wood.

# HOW A T-NUT WORKS

THE FIRST STEP IN OUR ASSEMBLY INSTRUCTIONS IS TO INSERT T-NUTS INTO THE CORNER POSTS. A T-NUT IS A FASTENER WHICH IS THREADED ON THE INSIDE AND IT FUNCTIONS JUST LIKE A STANDARD HEX NUT. YOU INSERT THE T-NUTS INTO THE PREDRILLED HOLES IN THE CORNER POSTS.

THE T-NUT HAS A BARREL SHAPED END WHICH GOES INTO THE HOLE IN THE CORNER POST. THE T-NUT ALSO HAS AN FLANGE SHAPED END WITH TEETH. THE TEETH PENETRATE INTO THE CORNER POST WOOD TO PREVENT THE T-NUT FROM SPINNING WHEN YOU TIGHTEN THE HEX HEAD BOLT.

SHOWN BELOW YOU WILL SEE THE T-NUT IS HAMMERED INTO THE CORNER POST ON THE BACK SIDE. THE BOARD IS BEING ATTACHED ON THE FRONT SIDE OF THE CORNER POST.

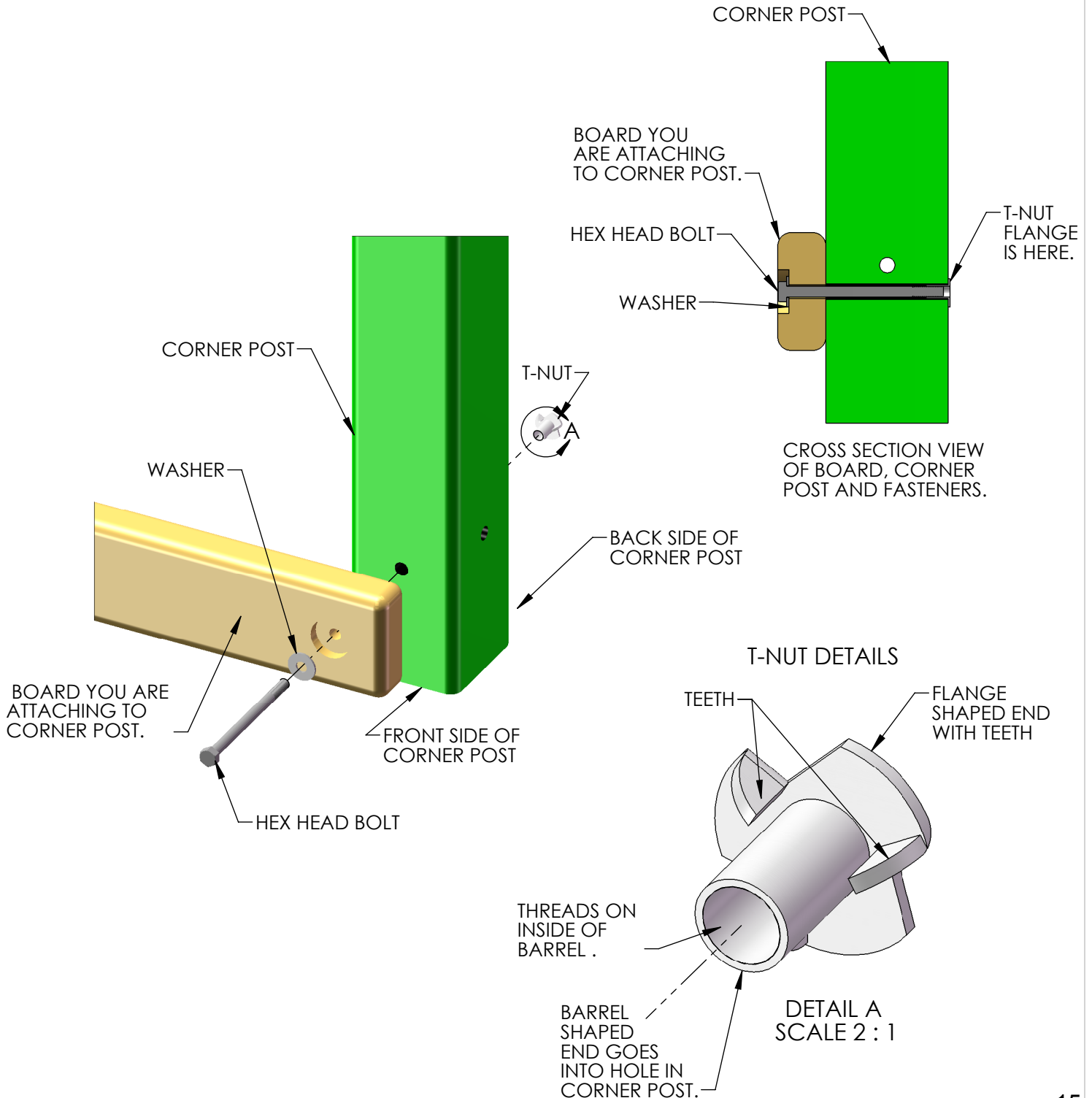

**Please familiarize yourself with the manual, parts/components and general construction process of your new playset before getting started.**

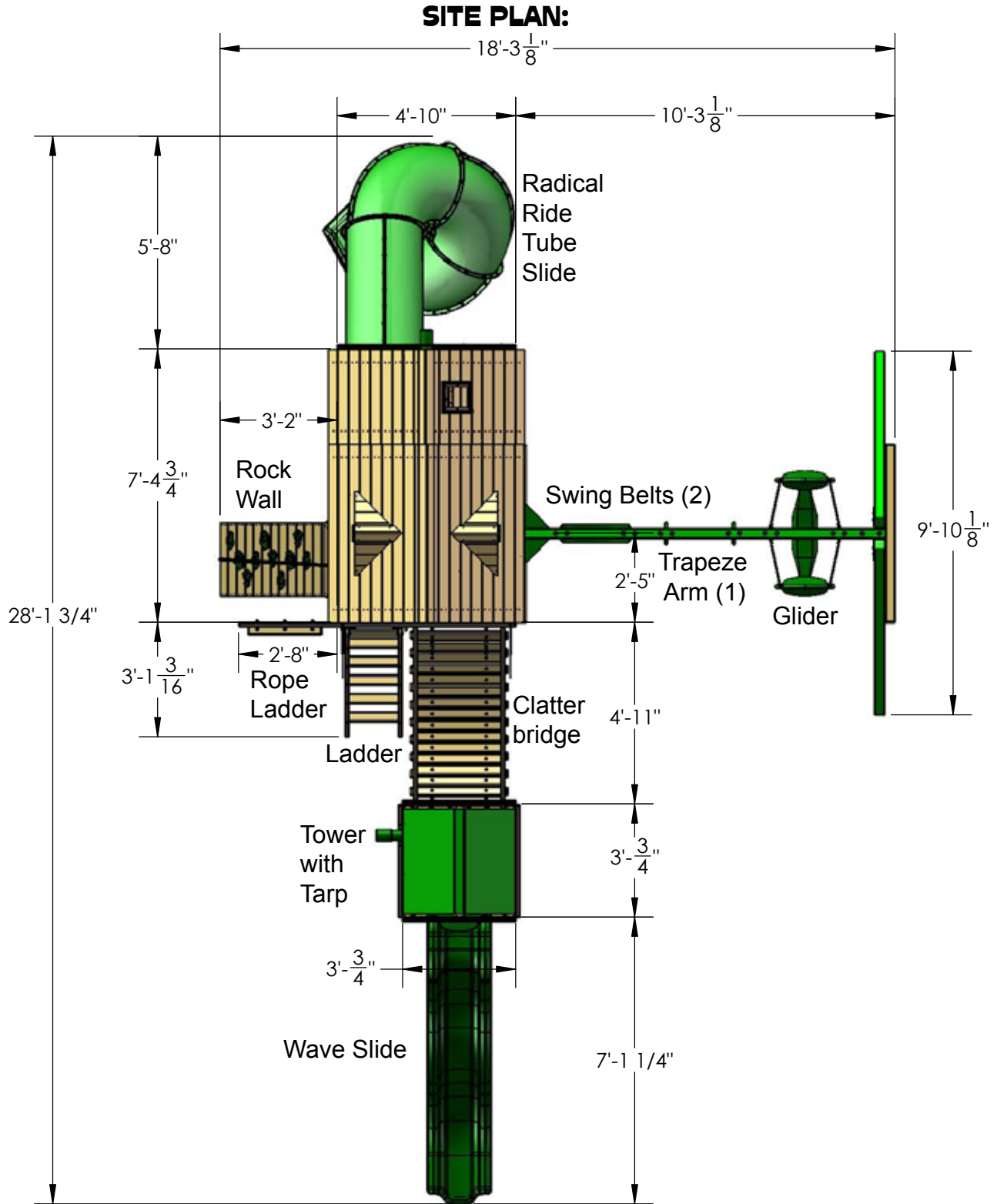

Playset height: 12'-8 1/2", Deck Heights (Lower 4'-9" / Upper 6'-11-1/2")

Swing Beam Height: 7'-8"

Approximate assembly time: 16 hours

**A 6 foot unobstructed safety perimeter around playset is recommended.**





## REQUIRED TOOL LIST:

- \_\_\_ Standard or Cordless Drill w/ Phillips Bit (#2 square bit provided)
- \_\_\_ 1/8" Drill Bit
- \_\_\_ 3/8" Drill Bit
- \_\_\_ 1/2" Wrench and Socket
- \_\_\_ 1/2" Deep Well Socket
- \_\_\_ 9/16" Deep Well Socket
- \_\_\_ 9/16" Wrench and Socket
- \_\_\_ Level
- \_\_\_ Tape Measure
- \_\_\_ Extension Cord (if using standard drill)
- \_\_\_ Hammer
- \_\_\_ Pencil
- \_\_\_ Locking Pliers (Vise Grips)
- \_\_\_ Shovel

## KIT CONTENTS:

### Swings, Slides, Accessories:

- \_\_\_ (Qty ) Description
- \_\_\_ (2) Swingbelts w/ Chains
- \_\_\_ (1) Trapeze w/Chains
- \_\_\_ (1) Glider Swing
- \_\_\_ (10) Rock Wall Grips (assorted colors)
- \_\_\_ (1) Mesh Sandbox Cover
- \_\_\_ (1) Tarp for Clatter bridge Tower
- \_\_\_ (1) Steering Wheel
- \_\_\_ (2) Telescope
- \_\_\_ (1) Periscope
- \_\_\_ (1) Flag Kit
- \_\_\_ (3) Plastic Safety Handles (pair)
- \_\_\_ (1) Tic Tac Toe Panel
- \_\_\_ (1) Assembly Manual
- \_\_\_ (1) Wave Slide
- \_\_\_ (1) Radical Ride Tube Slide

### Fort and Swing Beam Hardware:

See following pages and pages after PART II on page 120.

### Wood Components:

See following pages and pages after PART II on page 120.

### READ! VERY IMPORTANT!

If you are missing parts or have questions regarding the installation of our quality product PLEASE call us directly at the factory **(1-800-882-0272)**. Our trained staff will be happy to assist you.

**Customer service hours:**  
**Monday thru Friday 8AM – 5PM EST**  
**E-mail: [custsrv@gorillaplaysets.com](mailto:custsrv@gorillaplaysets.com)**



#8 X 1-1/2"  
WOOD SCREW  
QTY: 234

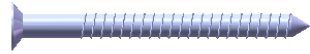

#8 X 2"  
WOOD SCREW  
QTY: 291

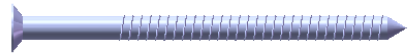

#8 X 2-1/2"  
WOOD SCREW  
QTY: 120

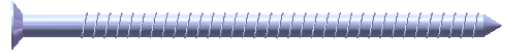

#8 X 3"  
WOOD SCREW  
QTY: 12

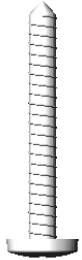
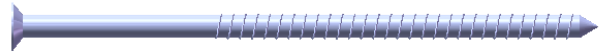

#14 X 1-1/4"  
PAN HEAD SCREW  
QTY: 7

9

8

7

6

5

4

3

2

1

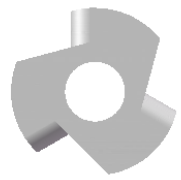

5/16" TEE NUT  
QTY: 62



3/8" LOCK NUT  
QTY: 21



TORQUE WASHER  
QTY: 19



3/8" WASHER  
QTY: 38



5/16" WASHER  
QTY: 96

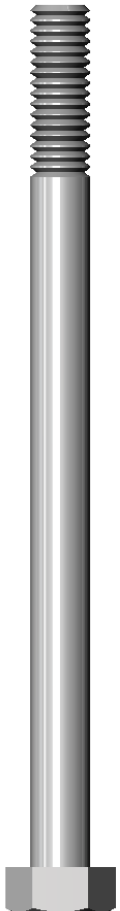

5/16 X 4-1/2"  
HEX BOLT  
QTY: 49



5/16 X 2-1/4"  
HEX BOLT  
QTY: 3







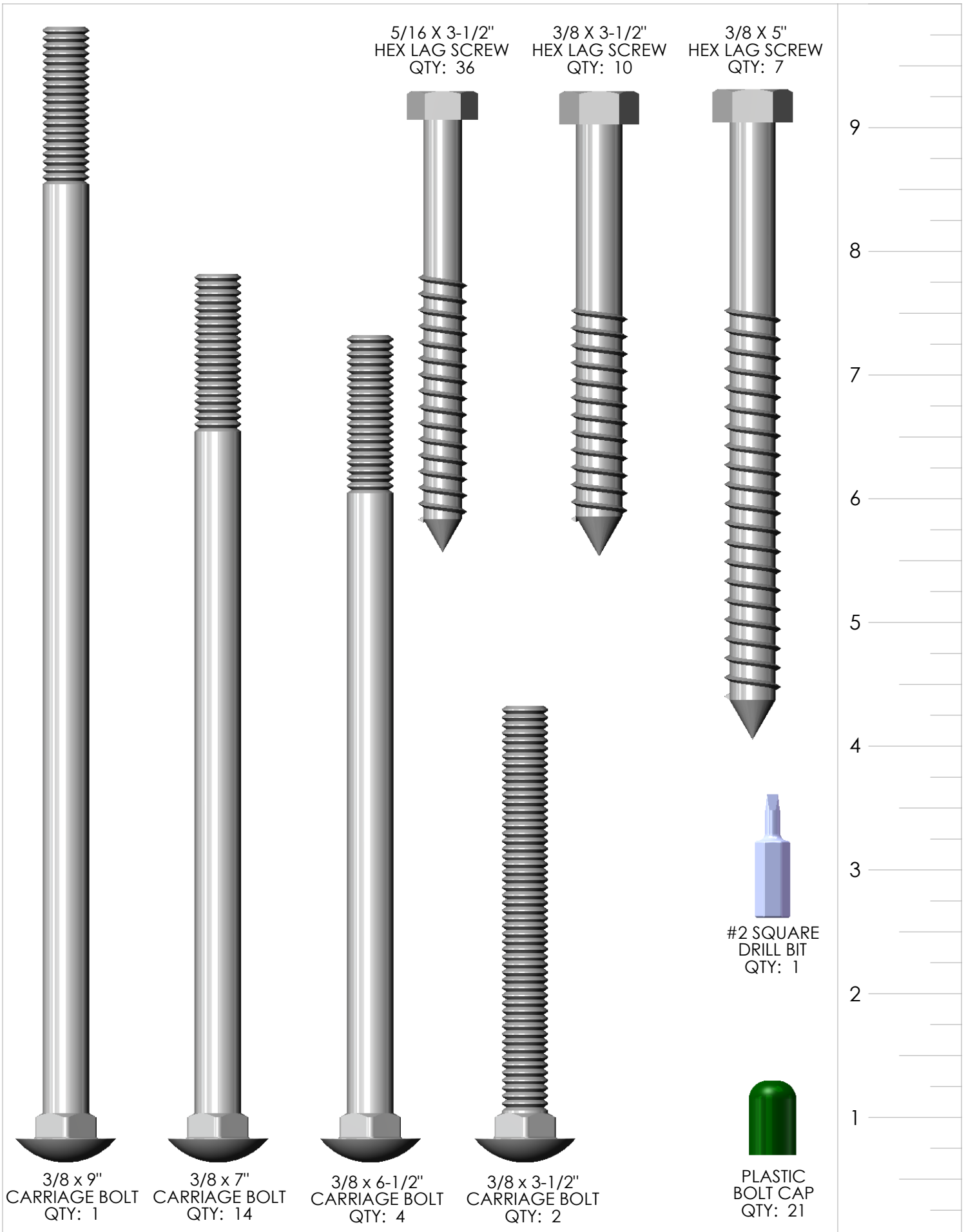



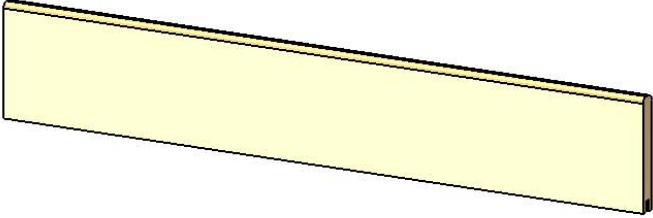

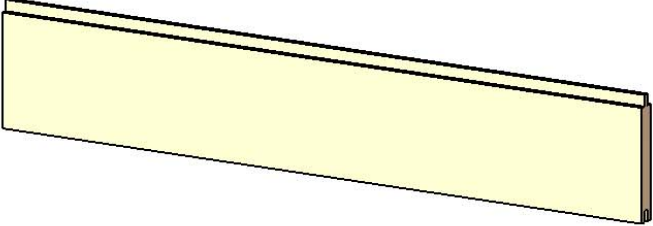
5/16 X 1-1/2"  
HEX BOLT  
QTY: 8

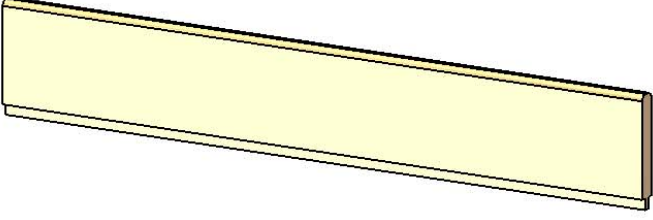
USE THE RULER TO THE RIGHT TO MEASURE YOUR BOLTS AND SCREWS. PICTURE VIEWS SHOWN ABOVE ARE 1:1 SCALE AND CAN BE USED TO MATCH BOLT AND SCREW SIZES.

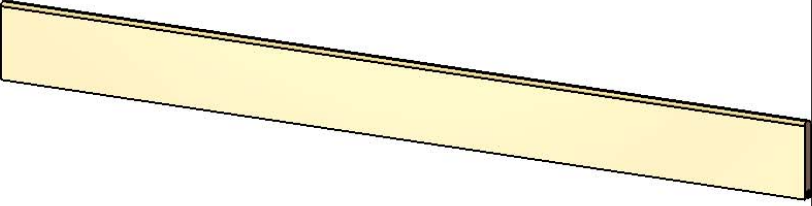

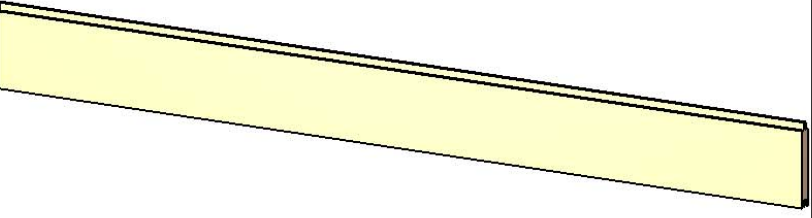
USE THE RULER TO THE RIGHT TO MEASURE YOUR BOLTS AND SCREWS. PICTURE VIEWS SHOWN ABOVE ARE 1:1 SCALE AND CAN BE USED TO MATCH BOLT AND SCREW SIZES.

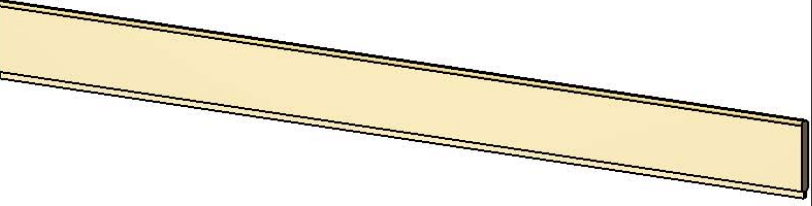
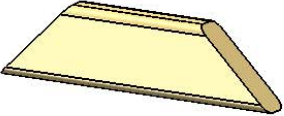
PICTURE	DESCRIPTION	QTY.
 	<p>1 X 5 X 30-3/4" GROOVE-ONLY UPPER LEVEL ROOF STARTER</p>	2
 	<p>1 X 6 X 30-3/4" TONGUE AND GROOVE UPPER LEVEL ROOF BOARD</p>	14
 	<p>1 X 5 X 30-3/4" TONGUE-ONLY UPPER LEVEL ROOF FINISHER</p>	2
 	<p>1 X 5 X 58" GROOVE-ONLY LOWER LEVEL ROOF STARTER</p>	2
 	<p>1 X 6 X 58" TONGUE AND GROOVE LOWER LEVEL ROOF BOARD</p>	14
 	<p>1 X 5 X 58" TONGUE-ONLY LOWER LEVEL ROOF FINISHER</p>	2
	<p>2 X 4 X 13" LOWER LEVEL ANGLE SUPPORT</p>	4

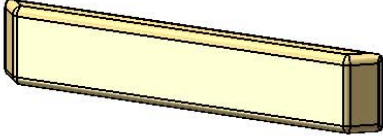
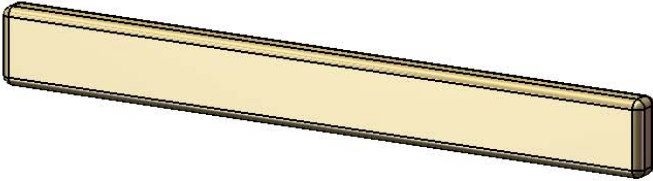
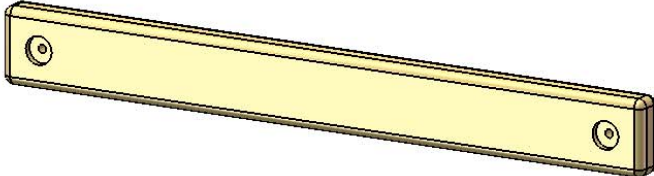
PICTURE	DESCRIPTION	QTY.
	2 X 4 X 15" UPPER LEVEL ANGLE SUPPORT	2
	2 X 4 X 17" LADDER STEP	5
	2 X 4 X 18" PICNIC TABLE STRINGER	1
	2 X 4 X 18" LOWER LEVEL ANGLE SUPPORT	4
	2 X 4 X 21" UPPER LEVEL ANGLE SUPPORT	2
	2 X 4 X 30-3/4" UPPER LEVEL CENTER DECK SUPPORT	4
	2 X 4 X 30-3/4" UPPER LEVEL DECK SUPPORT (TWO HOLES ON CENTER)	2

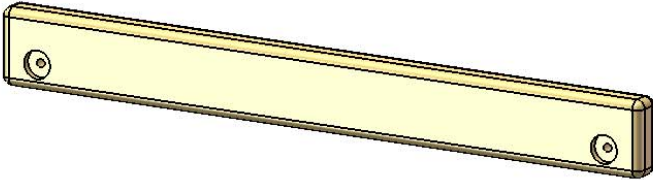
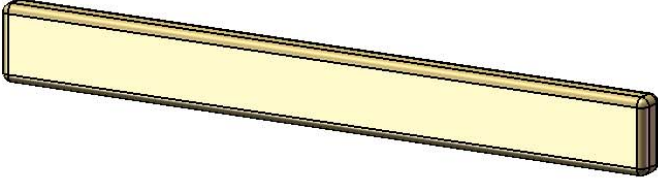
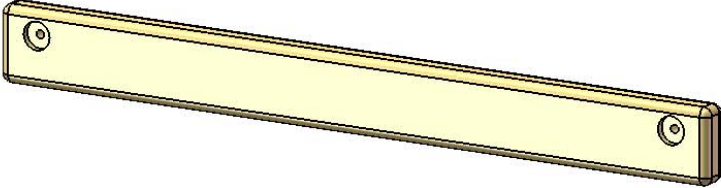
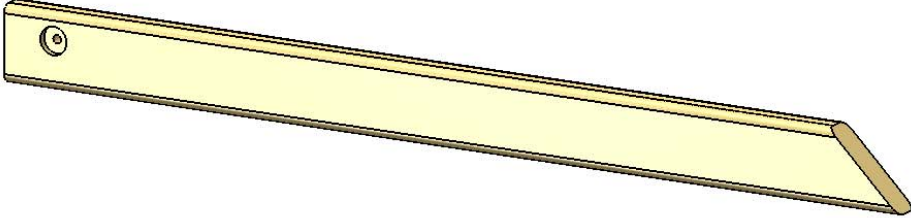
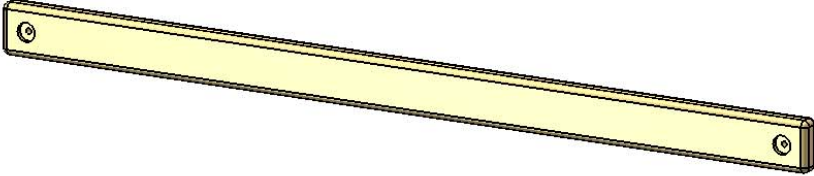
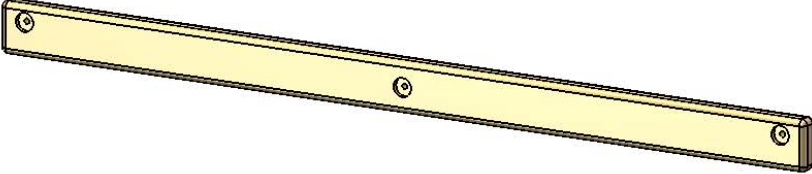
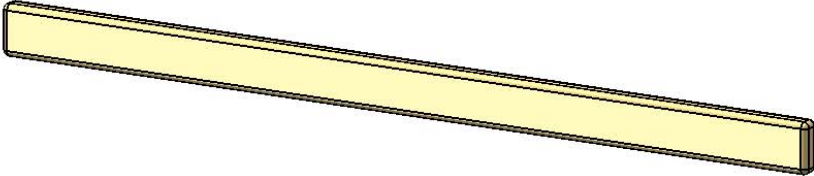

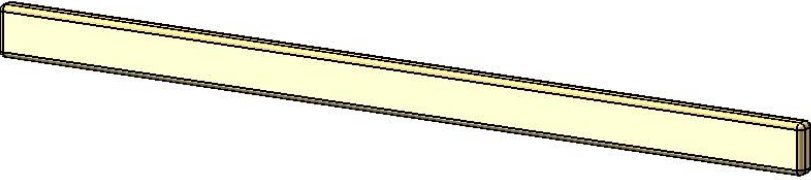
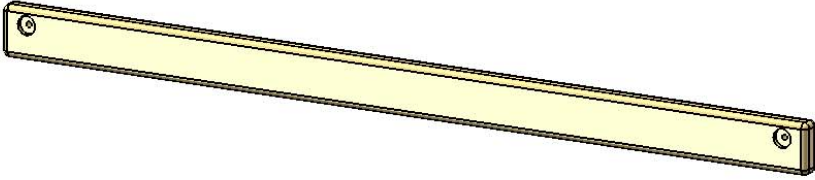
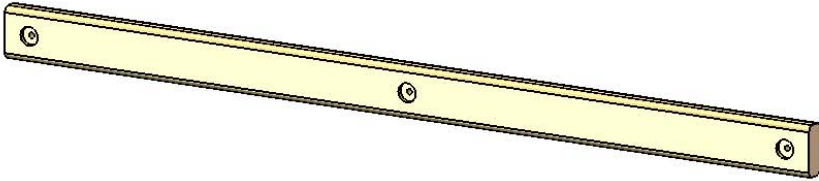
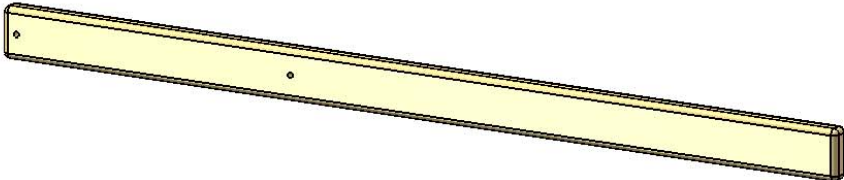
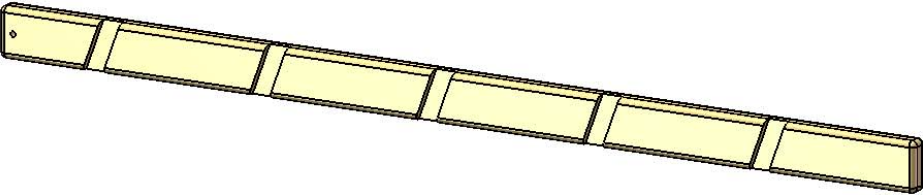
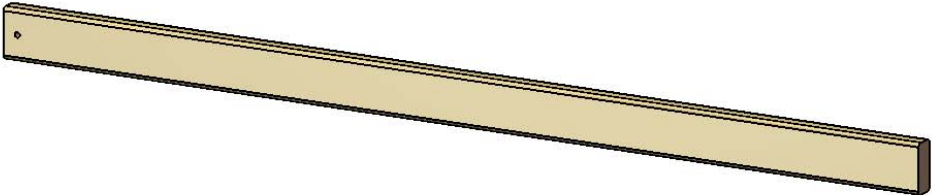
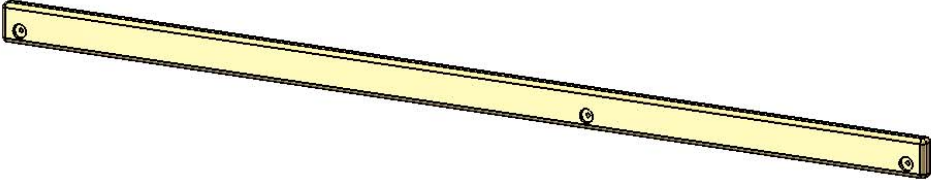
PICTURE	DESCRIPTION	QTY.
	2 X 4 X 30-3/4" UPPER LEVEL SIDE TOP PANEL BOARD (TWO HOLES OFFSET)	2
	2 X 4 X 31" LOWER LEVEL FRONT CENTER POST  <b>NOT USED</b>	1
	2 X 4 X 34" SANDBOX BOARD (TWO HOLES OFFSET)	2
	2 X 4 X 43" ROOF SUPPORT	4 LEFT 4 RIGHT
	2 X 4 X 58" LOWER DECK SUPPORT/ SANDBOX BOARD (TWO HOLES ON CENTER)	6
	2 X 4 X 58" 3-HOLE TOP PANEL BOARD (THREE HOLES, TWO OFFSET)	1
	2 X 4 X 58" LOWER DECK SUPPORT	2

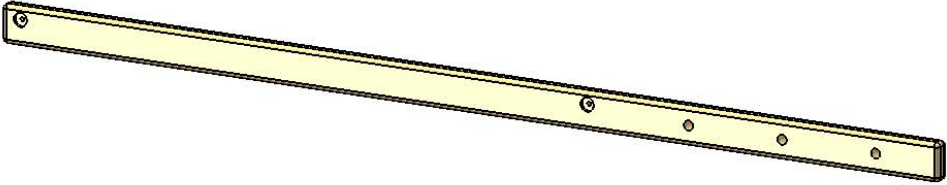
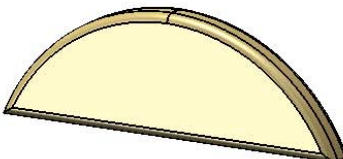
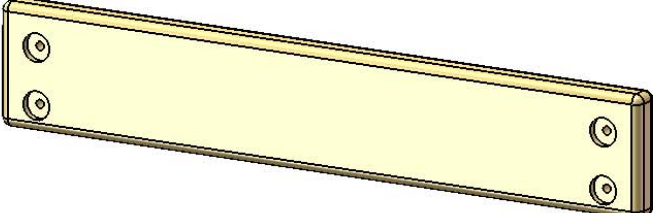
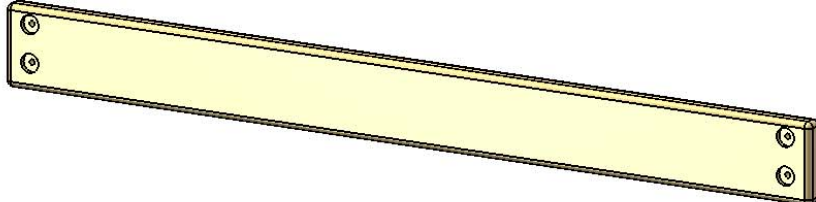
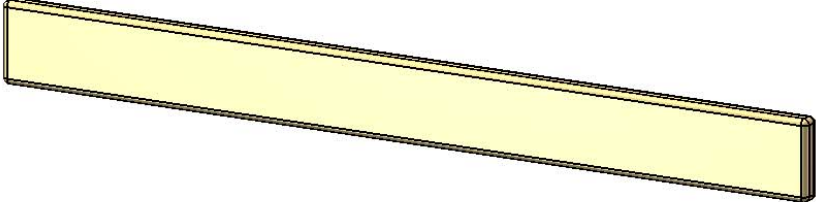
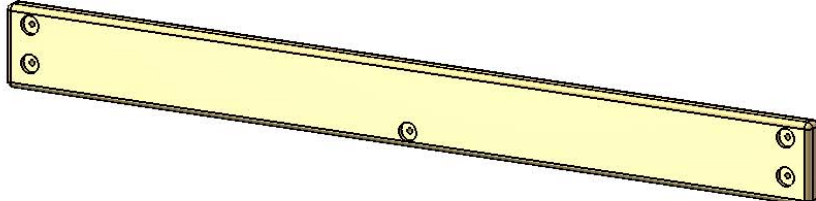
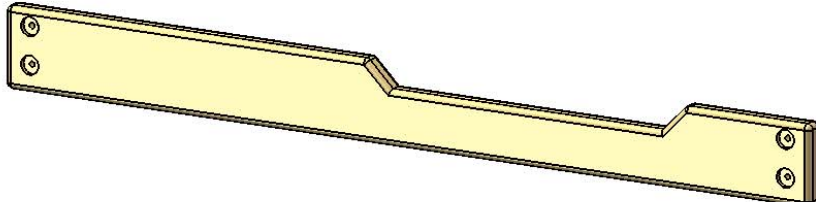
PICTURE	DESCRIPTION	QTY.
	2 X 4 X 58" PICNIC TABLE SUPPORT/UPPER LEVEL STEPS	7
	2 X 4 X 58" SANDBOX BOARD END PANEL BOARD BOTTOM PANEL BRD SIDE TOP PANEL BRD (TWO HOLES OFFSET)	4
	2 X 4 X 58" UPPER LEVEL DECK SUPPORT (THREE HOLES ON CENTER)	2
	2 X 4 X 60-1/8" LOWER LEVEL REAR CENTER POST	1
	2 X 4 X 66" LADDER SIDE	1 LEFT 1 RIGHT
	2 X 4 X 66" ROCK WALL SIDE	2
	2 X 4 X 88-3/4" SIDE SANDBOX BOARD	1 LEFT 1 RIGHT

PICTURE	DESCRIPTION	QTY.
	2 X 4 X 90" ROPE LADDER RUNNER (5 HOLES, TWO OFFSET)	1
	2 X 6 X 16" SUN	3
	2 X 6 X 30-3/4" UPPER LEVEL SIDE BOTTOM PANEL BOARD (FOUR HOLES OFFSET)	3
	2 X 6 X 58" BOTTOM PANEL BOARD (FOUR HOLES OFFSET)	2
	2 X 6 X 58" PICNIC TABLE TOP & SEATS	8
	2 X 6 X 58" REAR BOTTOM PANEL BOARD (FIVE HOLES OFFSET)	1
	2 X 6 X 58" SIDE FACE BOARD (FOUR HOLES OFFSET)	1

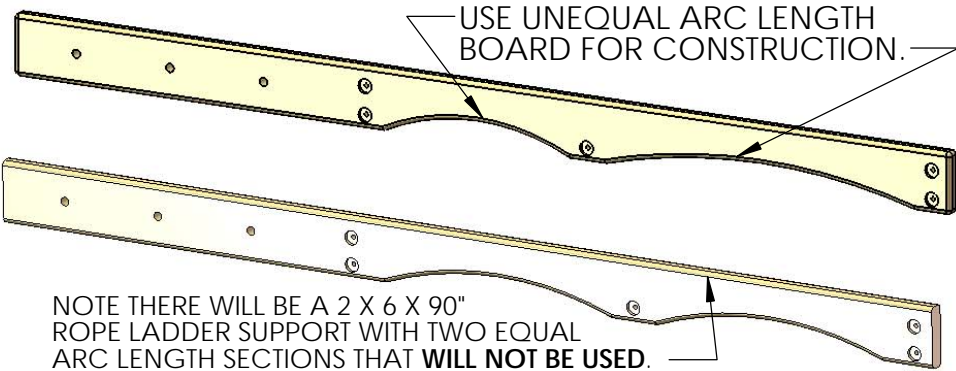
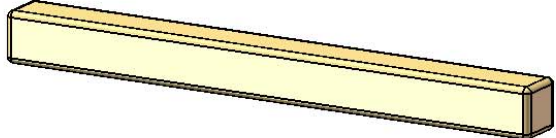
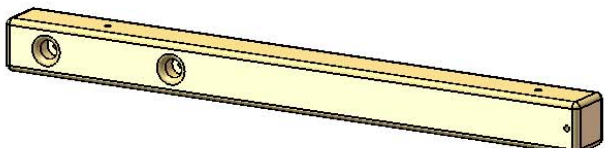
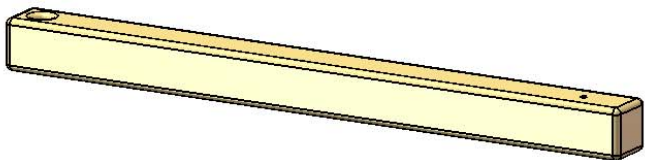
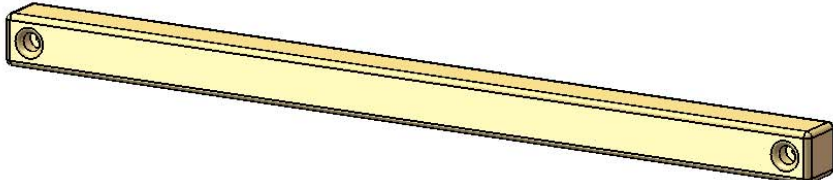

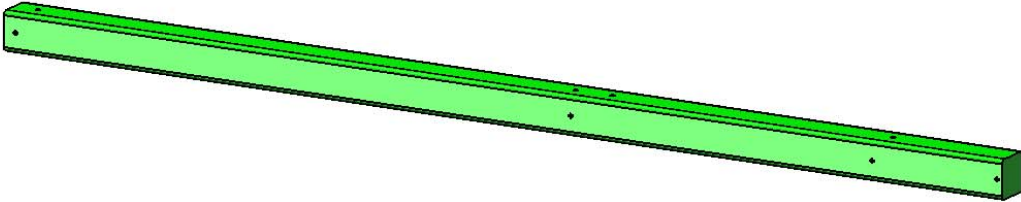
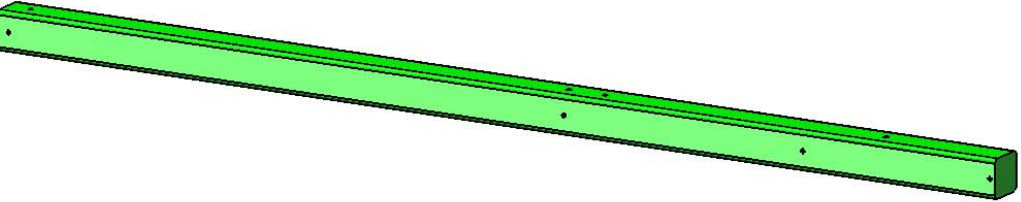
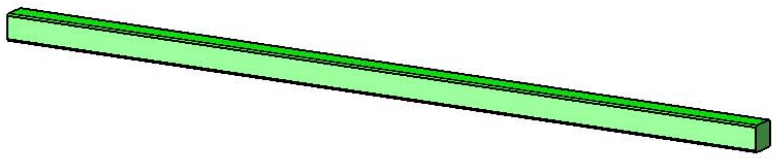
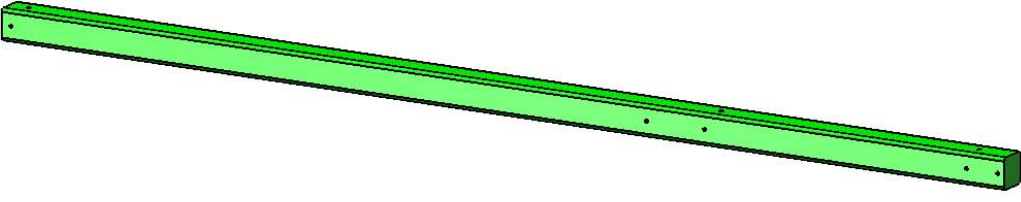
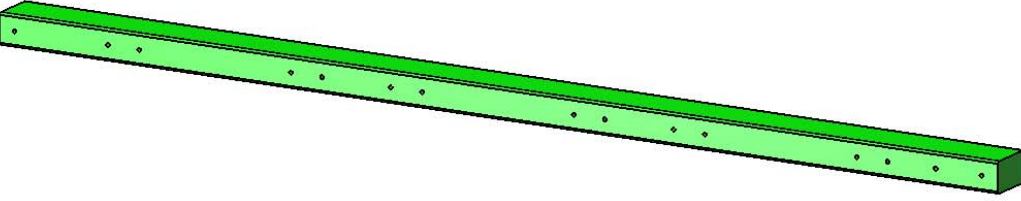

PICTURE	DESCRIPTION	QTY.
 <p data-bbox="519 115 1023 178">USE UNEQUAL ARC LENGTH BOARD FOR CONSTRUCTION.</p> <p data-bbox="170 409 771 483">NOTE THERE WILL BE A 2 X 6 X 90" ROPE LADDER SUPPORT WITH TWO EQUAL ARC LENGTH SECTIONS THAT <b>WILL NOT BE USED.</b></p>	<p data-bbox="1128 178 1396 304">2 X 6 X 90" ROPE LADDER SUPPORT (EIGHT HOLES, 5 OFFSET)</p>	<p data-bbox="1469 220 1494 273">1</p>
	<p data-bbox="1136 546 1388 672">4 X 4 X 37-11/16" UPPER LEVEL FRONT CENTER POST</p>	<p data-bbox="1469 556 1494 609">1</p>
	<p data-bbox="1128 766 1372 861">4 X 4 X 41-5/16" UPPER LEVEL LAG POST</p>	<p data-bbox="1469 808 1494 861">2</p>
	<p data-bbox="1128 1050 1356 1165">4 X 4 X 44-1/4" UPPER LEVEL REAR CENTER POST</p>	<p data-bbox="1469 1081 1494 1134">1</p>
	<p data-bbox="1128 1333 1388 1428">4 X 4 X 58" SWING LEG CROSS-MEMBER</p>	<p data-bbox="1469 1365 1494 1417">1</p>
	<p data-bbox="1128 1627 1339 1722">4 X 4 X 58" SWING BEAM MOUNT</p>	<p data-bbox="1469 1638 1494 1690">1</p>
	<p data-bbox="1128 1890 1372 1984">4 X 4 X 58" UPPER LEVEL DECK SUPPORT</p>	<p data-bbox="1469 1911 1494 1963">1</p>

PICTURE	DESCRIPTION	QTY.
	PLASTIC COATED 4 X 4 X 96" LOWER FRONT CORNER POST	2
	PLASTIC COATED 4 X 4 X 96" LOWER REAR CORNER POST	2
	PLASTIC COATED 4 X 4 X 108" SWING LEGS	2
	PLASTIC COATED 4 X 4 X 120" UPPER LEVEL CORNER POST	2
	PLASTIC COATED 4 X 6 X 120" SWING BEAM	1
	5/4 X 2 X 10" SMALL RAY	18
	1-3/8 X 1-5/8 X 10-1/2"L TIC- TAC-TOE BOARD	2

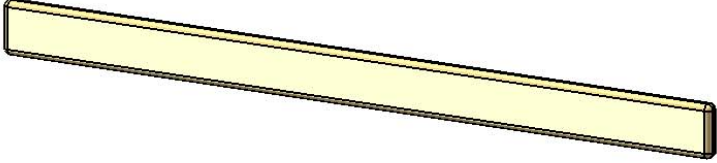
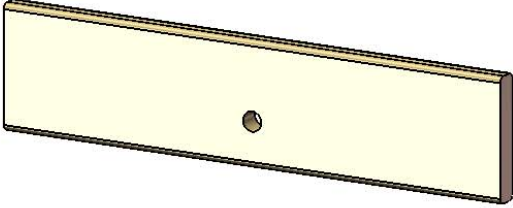
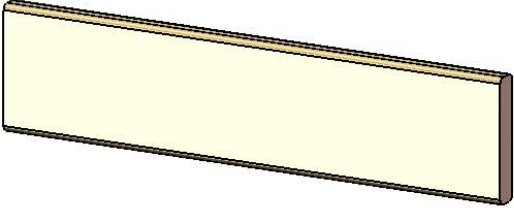
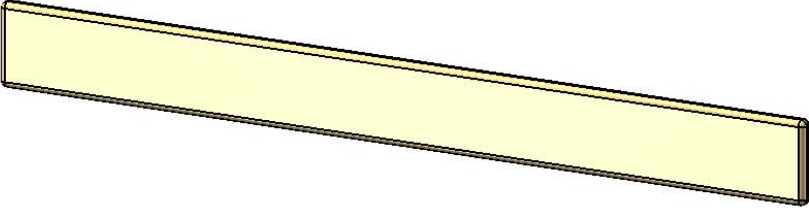
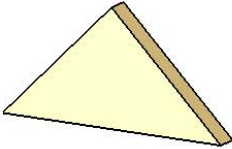
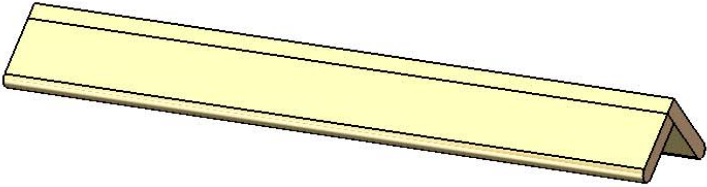
PICTURE	DESCRIPTION	QTY.
	5/4 X 2 X 16" LARGE RAY	3
	5/4 X 3 X 18-3/4" LADDER BACK	1
	5/4 X 3 X 23-7/8" ROCK WALL CAP	1
	5/4 X 3 X 28" LOWER DECK PANEL SLAT	13
	5/4 X 3 X 33-1/2" UPPER DECK PANEL SLAT	12
	5/4 X 3 X 42" SUN SUPPORT	3
	5/4 X 4 X 23-3/4" DECK SPACER	4

PICTURE	DESCRIPTION	QTY.
	5/4 X 4 X 51" DECK SPACER	2
	5/4 X 6 X 23-7/8" BOTTOM ROCK WALL BOARD	1
	5/4 X 6 X 23-7/8" ROCK WALL BOARD	11
	5/4 X 6 X 58" DECK BOARD	13
	5/4 X 6 X 10" ROOF SUPPORT	4
	30-3/4" ROOF PEAK  58" ROOF PEAK	1  1

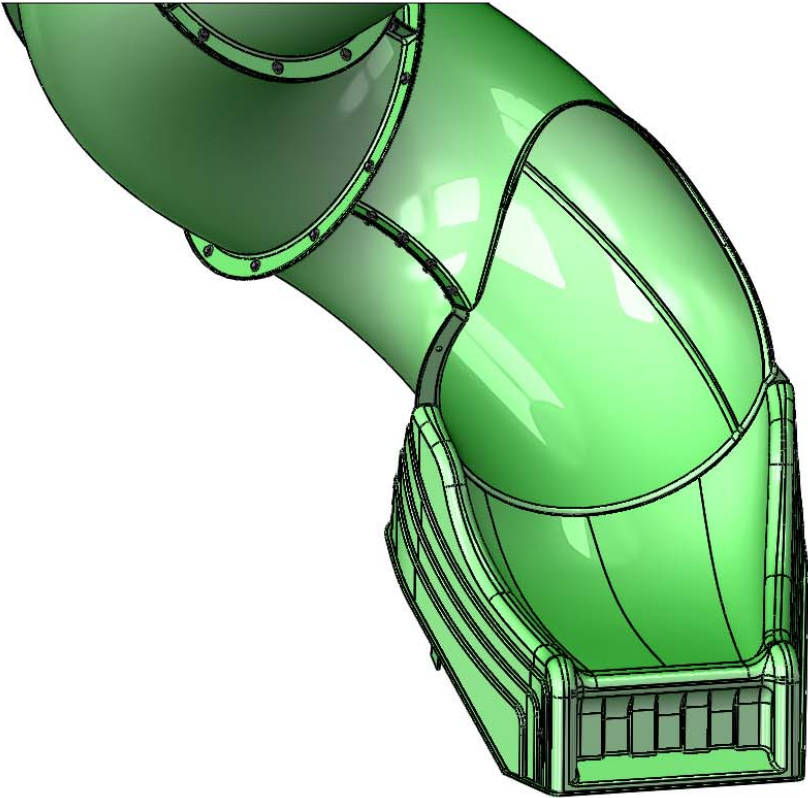
COUNT AND ORGANIZE YOUR LUMBER INTO LIKE STACKS (2 X 4, 2 X 6, 4 X 4, 4 X 6, ETC.). THIS WILL HELP IN IDENTIFYING COMPONENTS AND REDUCE YOUR BUILDING TIME

PICTURE	DESCRIPTION	QTY.
	<p>10' WAVE SLIDE</p>	<p>1</p>
	<p>RAD RIDE TUBE SLIDE</p>	<p>1</p>
	<p>SWINGS W/CHAINS</p> <p>TRAPEZE BAR W/CHAINS</p>	<p>2</p> <p>1</p>

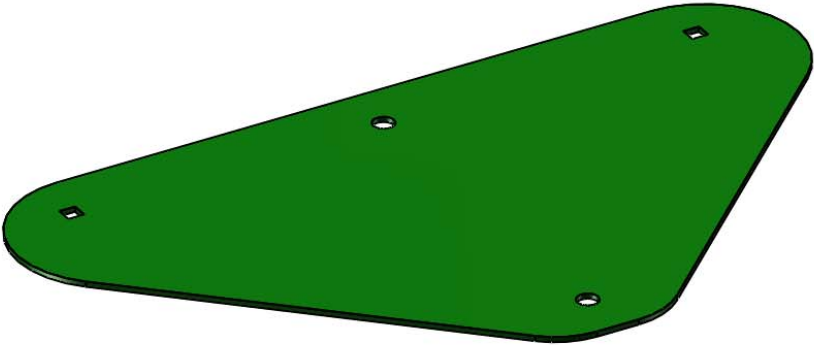
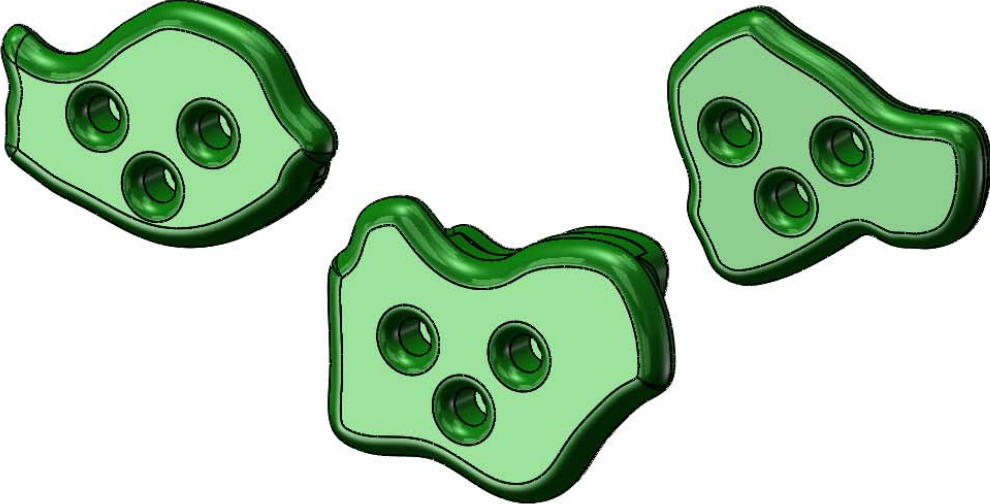
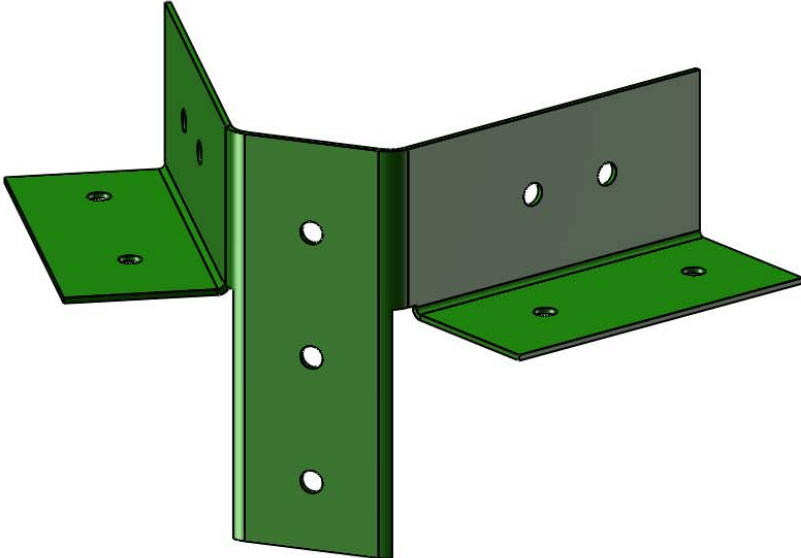
PICTURE	DESCRIPTION	QTY.
	SWING PLATE	1
	CLIMBING ROCKS	10
	A-FRAME SWING LEG BRACKET	1
NOT SHOWN	HARDWARE BOX INSTRUCTIONS	1 EA.

PICTURE	DESCRIPTION	QTY.
 <p>A technical drawing of an iron ductile swing hanger. It consists of a flat rectangular plate with two circular holes, from which two curved arms extend downwards. These arms are connected to a central vertical link that has a circular ring at its bottom end.</p>	<p>IRON DUCTILE SWING HANGERS</p>	<p>6</p>
 <p>A 3D rendering of a green telescope mounted on a base. The telescope has a long cylindrical body with a lens at the front and a viewing eyepiece at the back. It is supported by a green mounting bracket that is attached to a circular base with four screws and two small vertical pins.</p>	<p>TELESCOPE</p>	<p>2</p>
 <p>A 3D rendering of a green periscope. It has a long, tapered cylindrical body. At the top, there is a lens. At the bottom, there is a viewing eyepiece. A central handle with two circular grips is attached to the side of the body.</p>	<p>PERISCOPE</p>	<p>1</p>

PICTURE

DESCRIPTION

QTY.



STEERING  
WHEEL

1

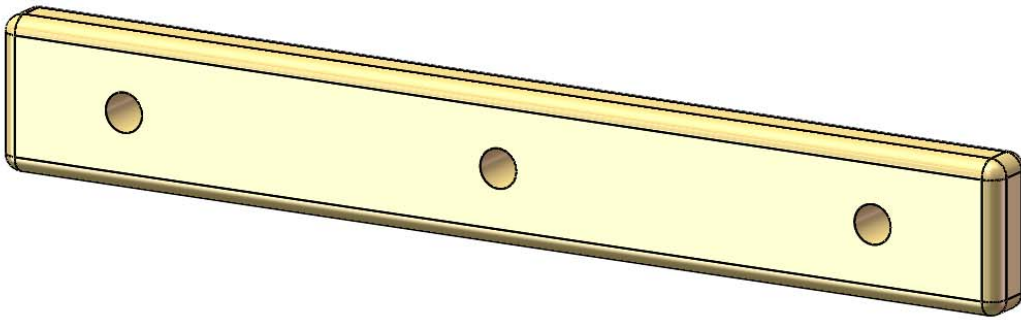

ROPE  
LADDER  
STEPS

6

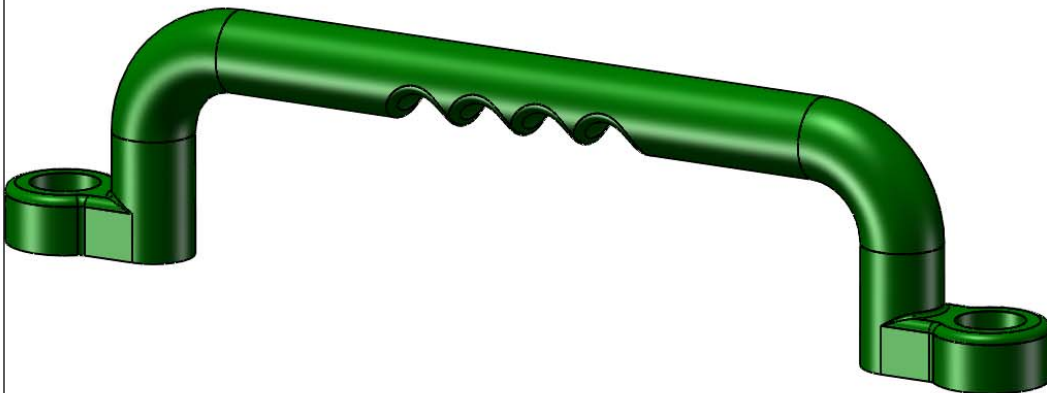

SAFETY  
HANDLES  
(PAIR)

3



PICTURE

DESCRIPTION

QTY.

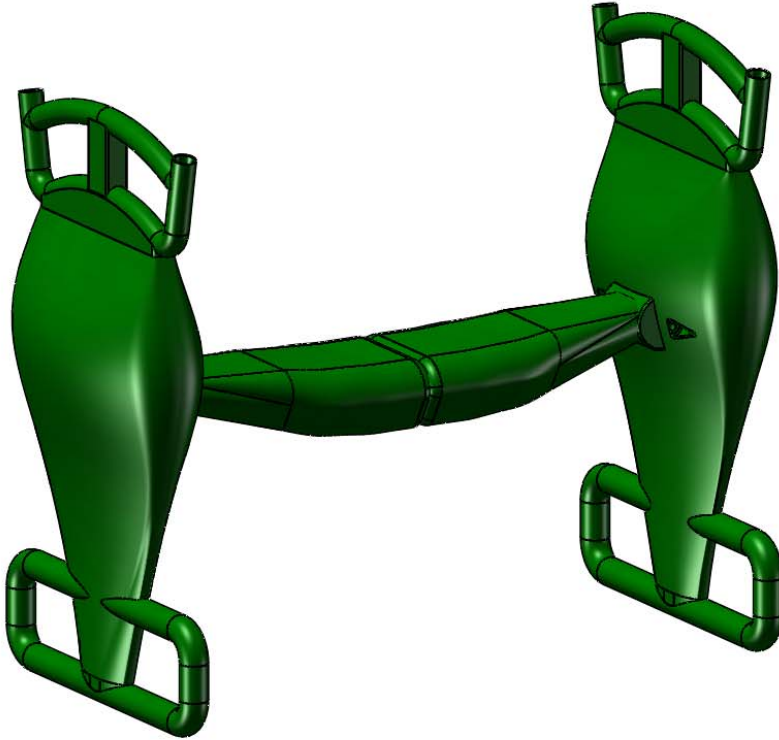

GLIDER  
SWING

1

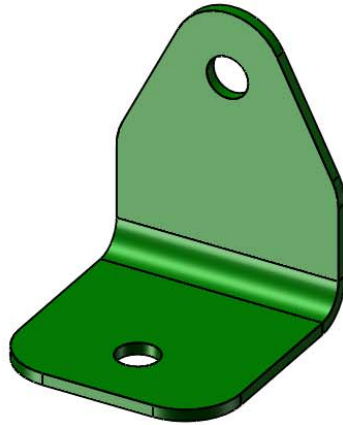

90°  
GREEN  
BRACKET

4

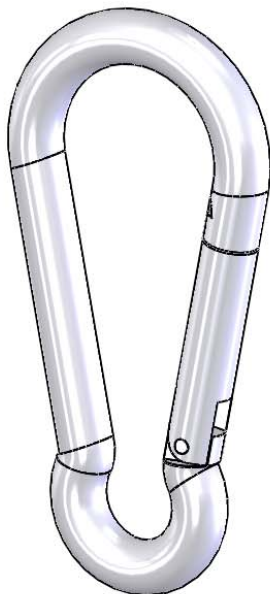

SPRING  
CLIP

6

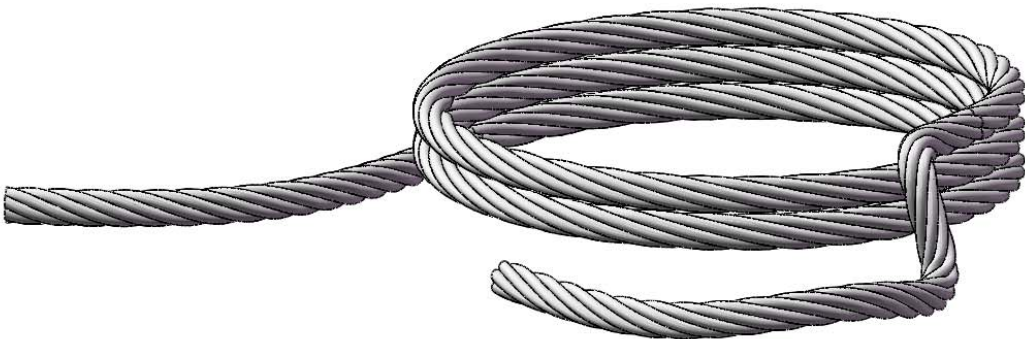
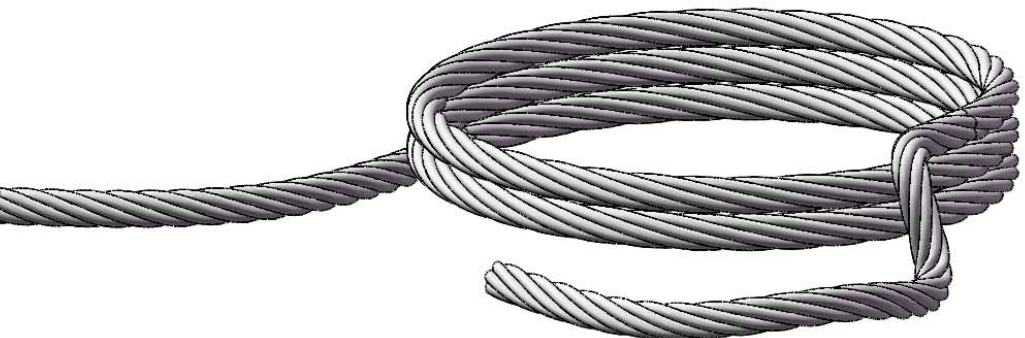
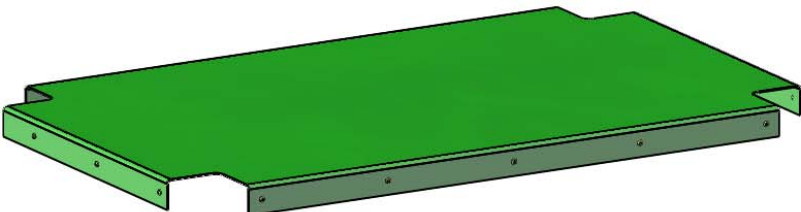
PICTURE	DESCRIPTION	QTY.
	10' ROPE	1
	15' ROPE	3
	SANDBOX COVER (MESH WITH BUTTON SNAPS)	1

PICTURE

DESCRIPTION

QTY.

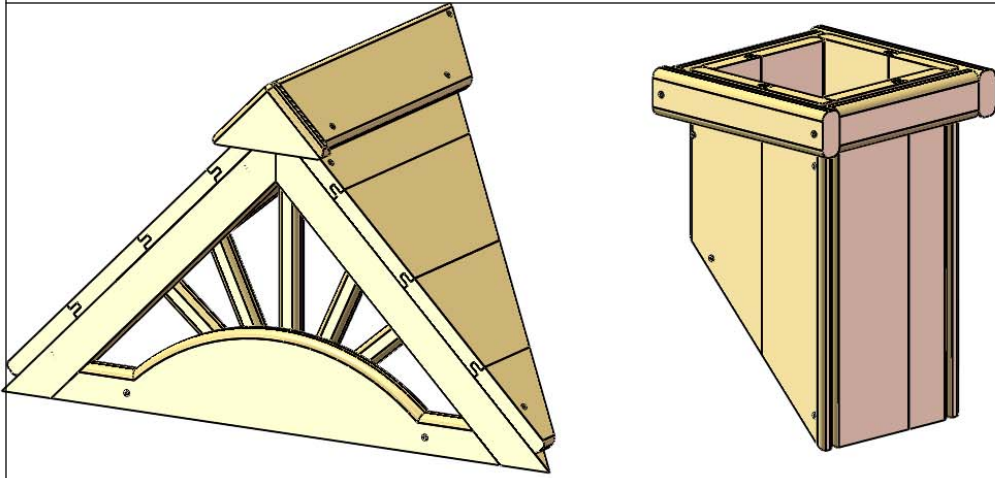

UNASSEMBLED  
DORMER

2

UNASSEMBLED  
CHIMNEY

1

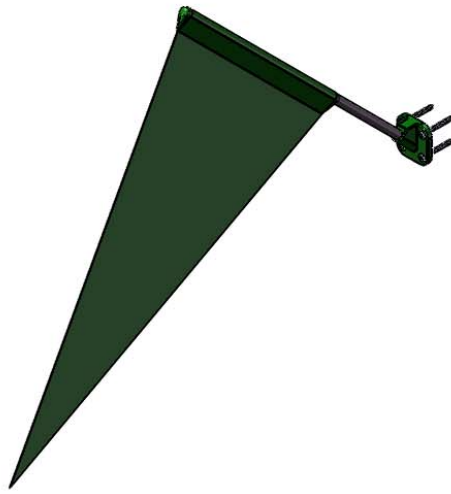

FLAG KIT

2

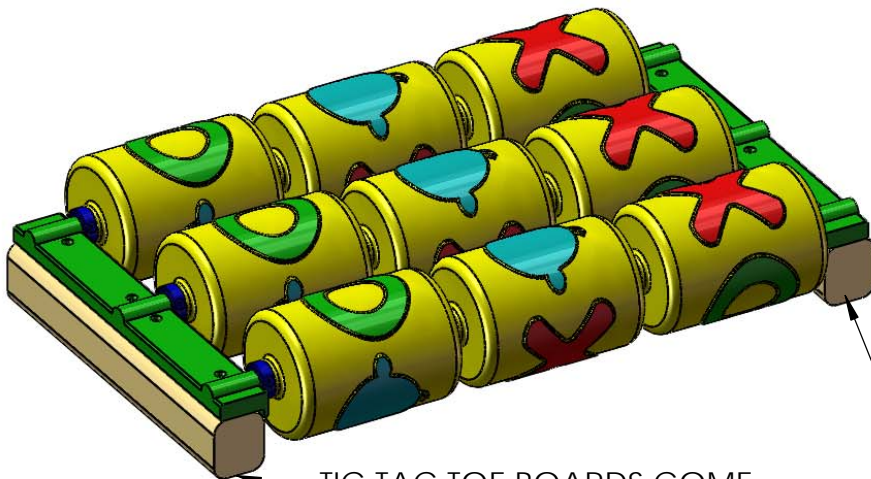

TIC-TAC-TOE  
PANEL

1

1-3/8" x 1-  
5/8" x 10-  
1/2" TIC TAC  
TOE  
BOARDS

2

TIC TAC TOE BOARDS COME  
SEPARATE FROM TIC TAC TOE PANEL.

# STEP 1: T-NUTS

1: THIS STEP IS CRITICAL TO BUILDING THE FORT PROPERLY. IF ANY MISTAKES ARE MADE HERE, YOU WILL NEED TO DIS-ASSEMBLE AND THEN RE-ASSEMBLE TO MAKE YOUR CORRECTIONS.

2: MAKE SURE HOLES ARE FREE OF ANY OBSTRUCTIONS. USE A BOLT TO CLEAN OUT ANY DEBRIS.

3: LAY OUT EACH OF THE 4 X 4 X 96" CORNER POSTS IN THE AREA YOU INTEND ON BUILDING THE PLAYSET. NOTE THAT THERE ARE TWO FRONT AND TWO REAR CORNER POSTS.

4: USE THE DIAGRAM BELOW TO CORRECTLY IDENTIFY AND ORIENT THE NECESSARY DIRECTION THE POSTS SHOULD FACE.

5: USE A HAMMER TO SEAT THE T-NUTS AFTER INSERTING THEM INTO THE HOLES SHOWN IN THE DIAGRAM BELOW.

6: THE BARREL OF THE T-NUT SHOULD GO IN THE HOLE FIRST. HAMMER THE T-NUT UNTIL IT IS FLUSH/ALMOST FLUSH TO THE CORNER POSTS.

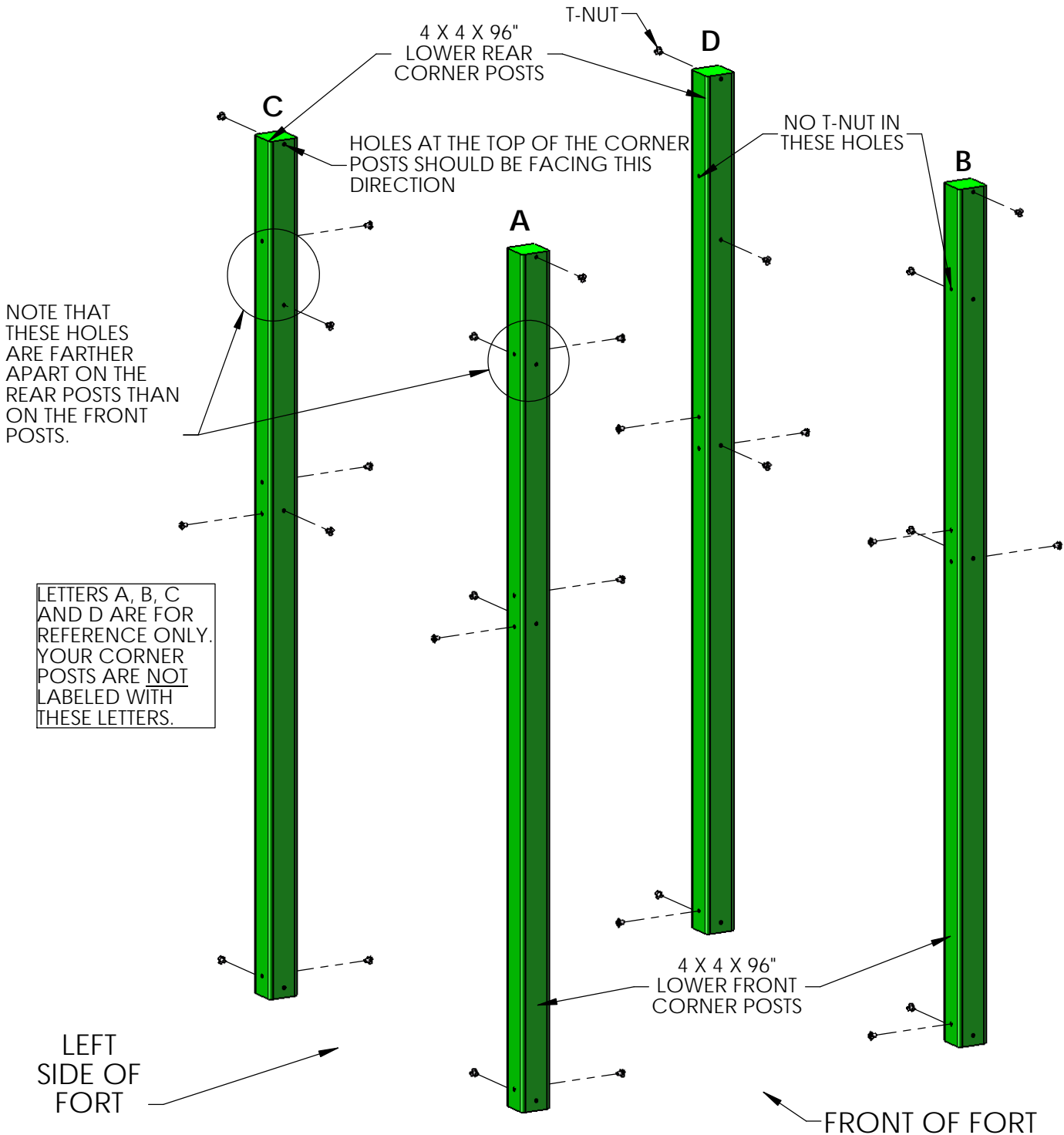

## STEP 2: ATTACHING THE SWING BEAM PLATE TO THE SWING BEAM SUPPORT

1: FIND THE 4 X 4 X 58" SWING BEAM SUPPORT.

2: FIND THE SWING BEAM PLATE. NOTICE THE TWO SQUARE HOLES ON THE SWING BEAM PLATE.

3: PLACE THE SWING BEAM PLATE ON TOP OF THE SWING BEAM SUPPORT AND LINE UP THE THREE HOLES ON THE PLATE WITH THE THREE HOLES ON THE SWING BEAM SUPPORT. MAKE SURE THE COUNTER-SUNK HOLES ARE ON THE OPPOSITE END OF THE SWING BEAM PLATE.

4: FASTEN THE SWING BEAM PLATE TO THE SWING BEAM SUPPORT WITH TWO 3-1/2" CARRIAGE BOLTS. THE SQUARE NECK OF THE CARRIAGE BOLT WILL FIT INSIDE THE SQUARE HOLES OF THE SWING BEAM PLATE. NO WASHER IS NEEDED.

5: FINISH INSTALLING THE SWING BEAM PLATE TO THE SWING BEAM SUPPORT WITH 3/8" WASHERS, AND 3/8" LOCK NUTS. INSTALL BOLT CAPS OVER ANY EXPOSED THREADS.

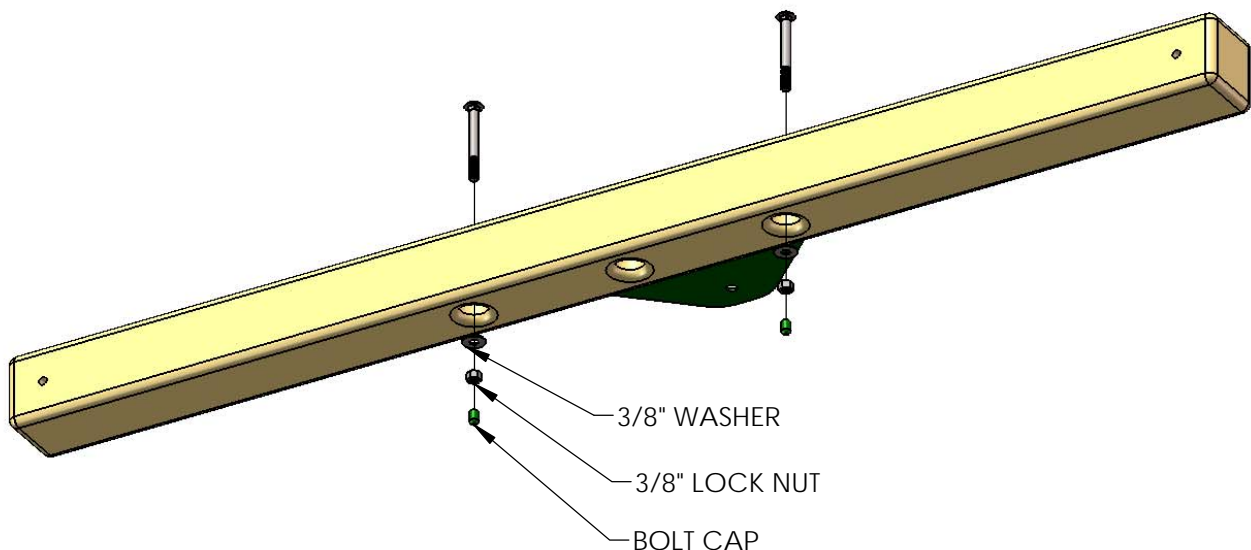
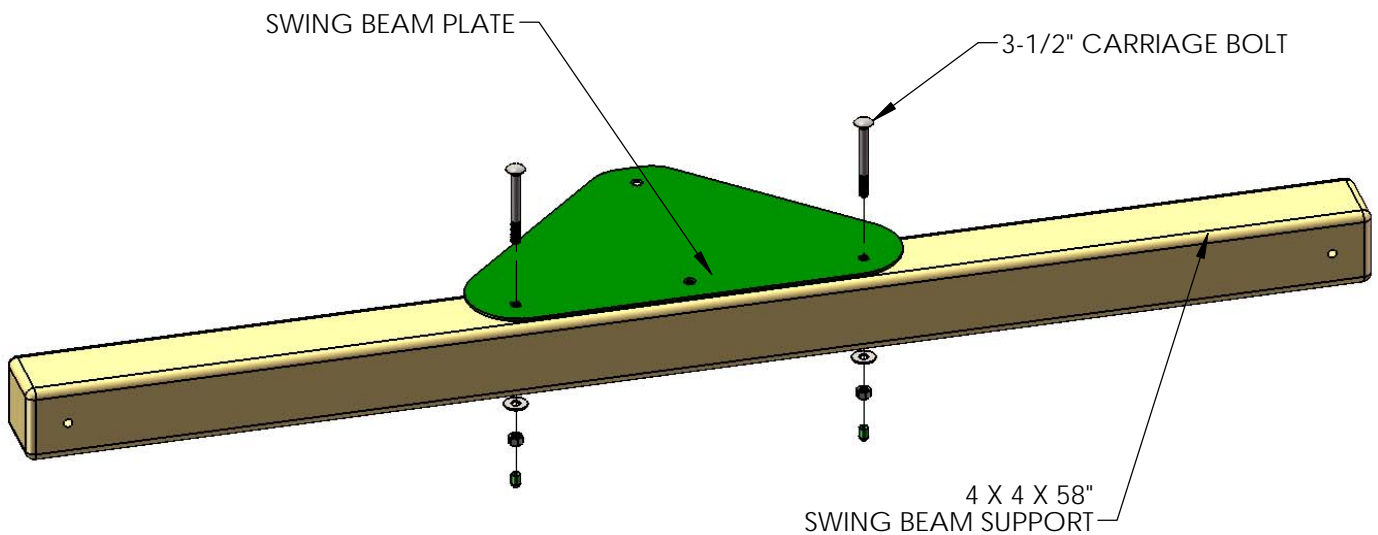

## STEP 3: FRAMING THE LEFT SIDE OF THE FORT

- 1: LAY THE 2 X 4 X 88-3/4" LEFT SIDE SANDBOX BOARD ON TOP OF THE LEFT SIDE CORNER POSTS AT THE BOTTOM OF THE CORNER POSTS. THE OFFSET HOLES IN THE LEFT SIDE SANDBOX BOARD MUST FACE UP.
- 2: USE 5/16 X 4-1/2" HEX BOLTS AND 5/16" WASHERS TO ATTACH THE HOLES OF THE LEFT SIDE SANDBOX BOARD TO THE T-NUTS INSTALLED ON THE CORNER POSTS.
- 3: LAY THE 2 X 6 X 58" SIDE FACE BOARD ON TOP OF THE LEFT SIDE CORNER POSTS IN THE MIDDLE OF THE CORNER POSTS. THE OFFSET HOLES IN THE SIDE FACE BOARD MUST FACE UP.
- 4: USE 5/16 X 4-1/2" HEX BOLTS AND 5/16" WASHERS TO ATTACH THE TOP HOLES OF THE SIDE FACE BOARD TO THE T-NUTS INSTALLED ON THE CORNER POSTS. THE BOTTOM HOLES WILL BE USED LATER.
- 5: LAY THE 2 X 4 X 58" SIDE TOP PANEL BOARD ON TOP OF THE LEFT SIDE CORNER POSTS. THE OFFSET HOLES IN THE SIDE TOP PANEL BOARD SHOULD FACE UP.
- 6: USE 5/16 X 4-1/2" HEX BOLTS AND 5/16" WASHERS TO ATTACH THE HOLES OF THE SIDE TOP PANEL BOARD TO THE T-NUTS INSTALLED ON THE CORNER POSTS.
- 7: DO NOT INSTALL LAG SCREWS AT THIS TIME.

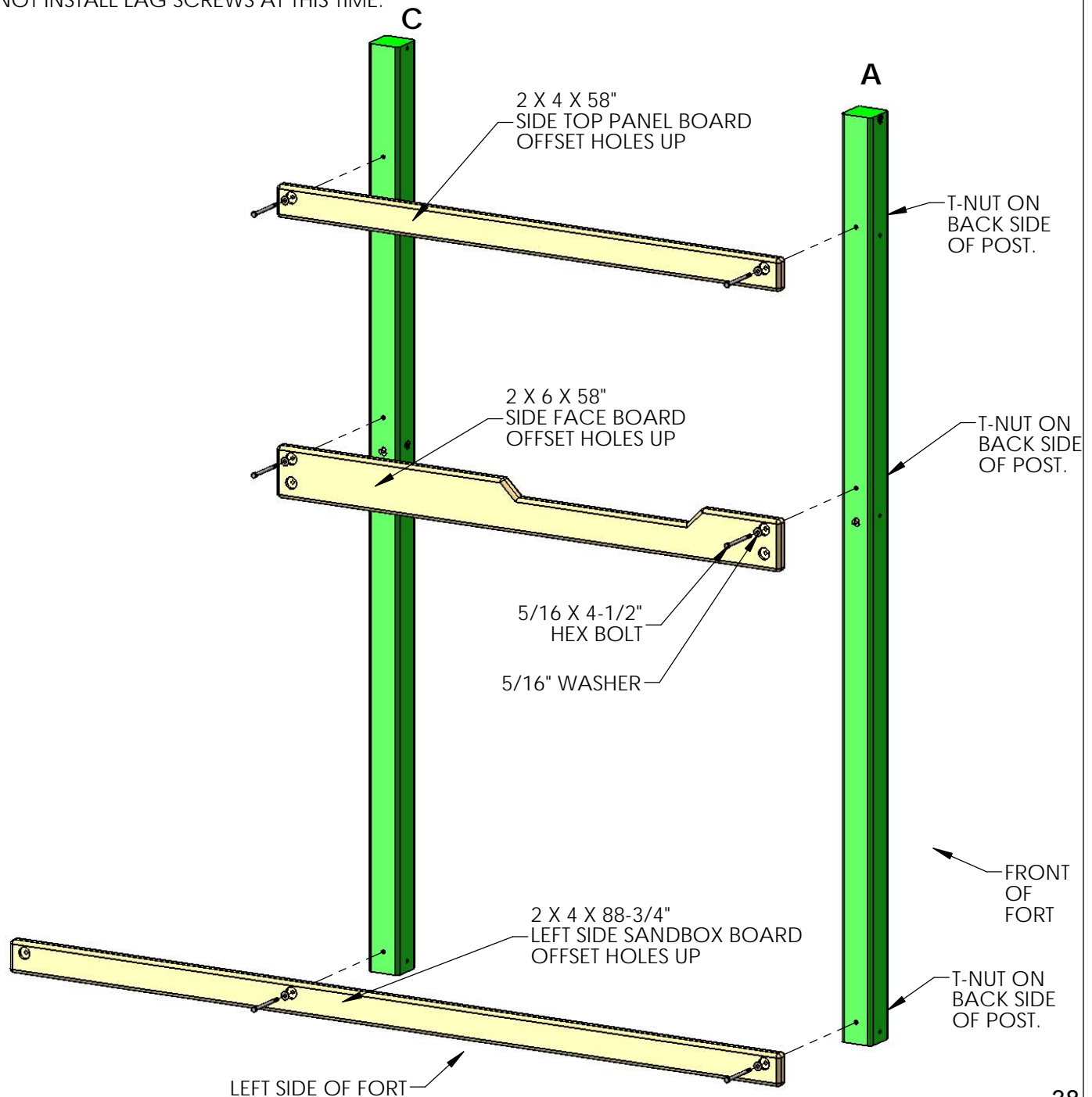

## STEP 4: FRAMING THE RIGHT SIDE OF THE FORT

1: LAY THE 2 X 4 X 88-3/4" RIGHT SIDE SANDBOX BOARD ON TOP OF THE RIGHT SIDE CORNER POSTS AT THE BOTTOM OF THE CORNER POSTS. THE OFFSET HOLES IN THE RIGHT SIDE SANDBOX BOARD MUST FACE UP.

2: USE 5/16 X 4-1/2" HEX BOLTS AND 5/16" WASHERS TO ATTACH THE HOLES OF THE RIGHT SIDE SANDBOX BOARD TO THE T-NUTS INSTALLED ON THE CORNER POSTS.

3: LAY THE 2 X 6 X 58" BOTTOM PANEL BOARD ON TOP OF THE RIGHT SIDE CORNER POSTS IN THE MIDDLE OF THE CORNER POSTS. THE OFFSET HOLES IN THE BOTTOM PANEL BOARD MUST FACE UP.

4: USE 5/16 X 4-1/2" HEX BOLTS AND 5/16" WASHERS TO ATTACH THE TOP HOLES OF THE BOTTOM PANEL BOARD TO THE T-NUTS INSTALLED ON THE CORNER POSTS. THE BOTTOM HOLES WILL BE USED LATER.

5: LAY THE 4 X 4 X 58" SWING BEAM SUPPORT ON TOP OF THE RIGHT SIDE CORNER POSTS. THE THREE COUNTERSUNK HOLES IN THE MIDDLE OF THE SWING BEAM SUPPORT MUST FACE DOWNWARD.

6: FIND TWO TORQUE WASHERS. PLACE A 6-1/2" CARRIAGE BOLT INSIDE THE TORQUE WASHER, MAKING SURE THAT THE TEETH ARE FACING IN THE SAME DIRECTION AS THE THREADS OF THE CARRIAGE BOLT. PLACE THE TORQUE WASHER/CARRIAGE BOLT ASSEMBLY INTO THE HOLES OF THE CORNER POST SO THAT THE HEAD OF THE CARRIAGE BOLT FACES THE INSIDE OF THE FORT. POST.

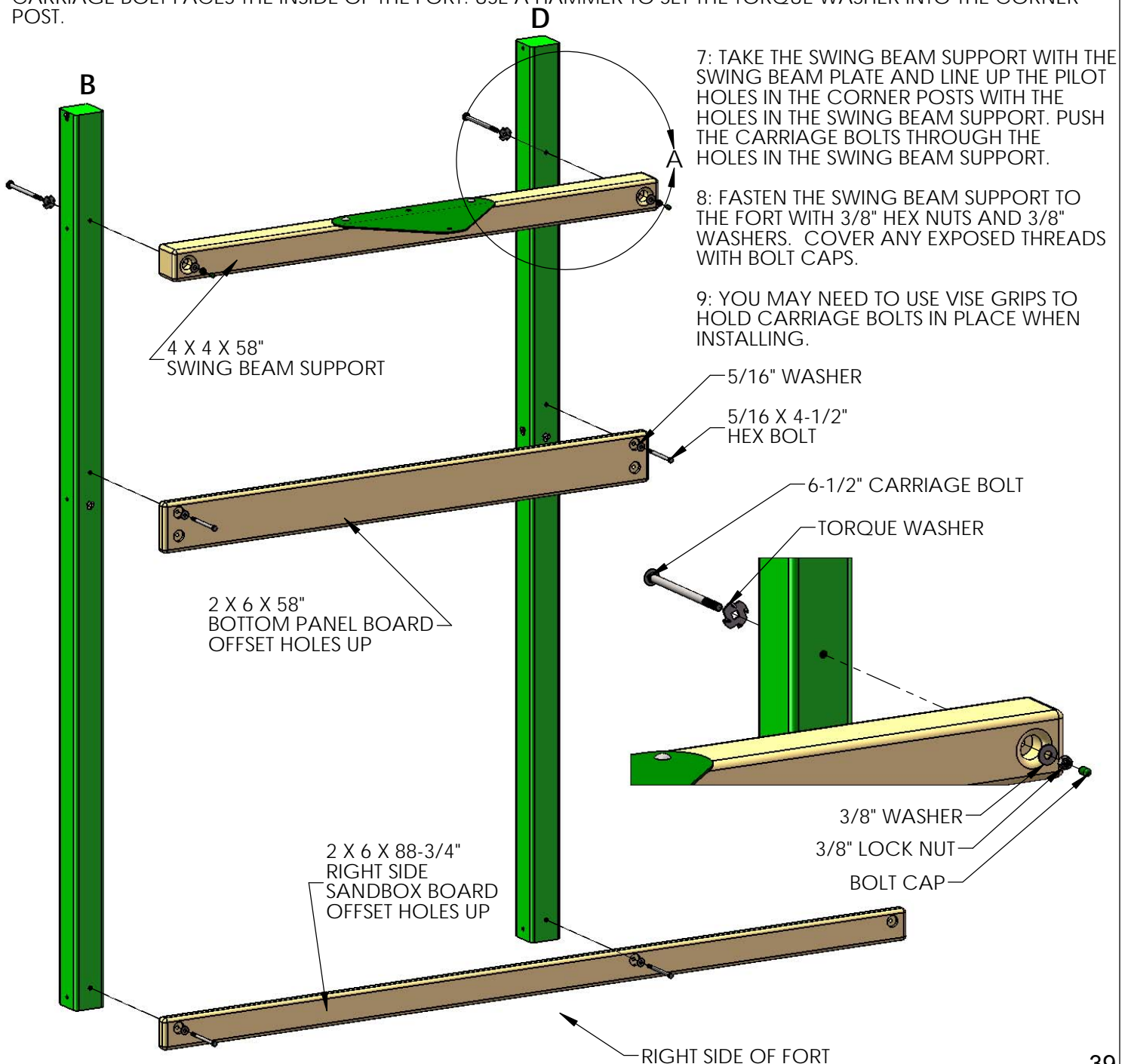

## STEP 5: LOWER DECK SUPPORTS

YOU WILL NEED AN EXTRA PERSON FOR THIS STEP.

1: WITH HELP, STAND UP THE LEFT AND RIGHT SIDE ASSEMBLIES.

2: FASTEN THE 2 X 4 X 58" LOWER DECK SUPPORTS TO THE HOLES AT 53" WITH 5/16" X 4-1/2" HEX BOLTS AND 5/16" WASHERS FROM THE INSIDE OF THE FORT

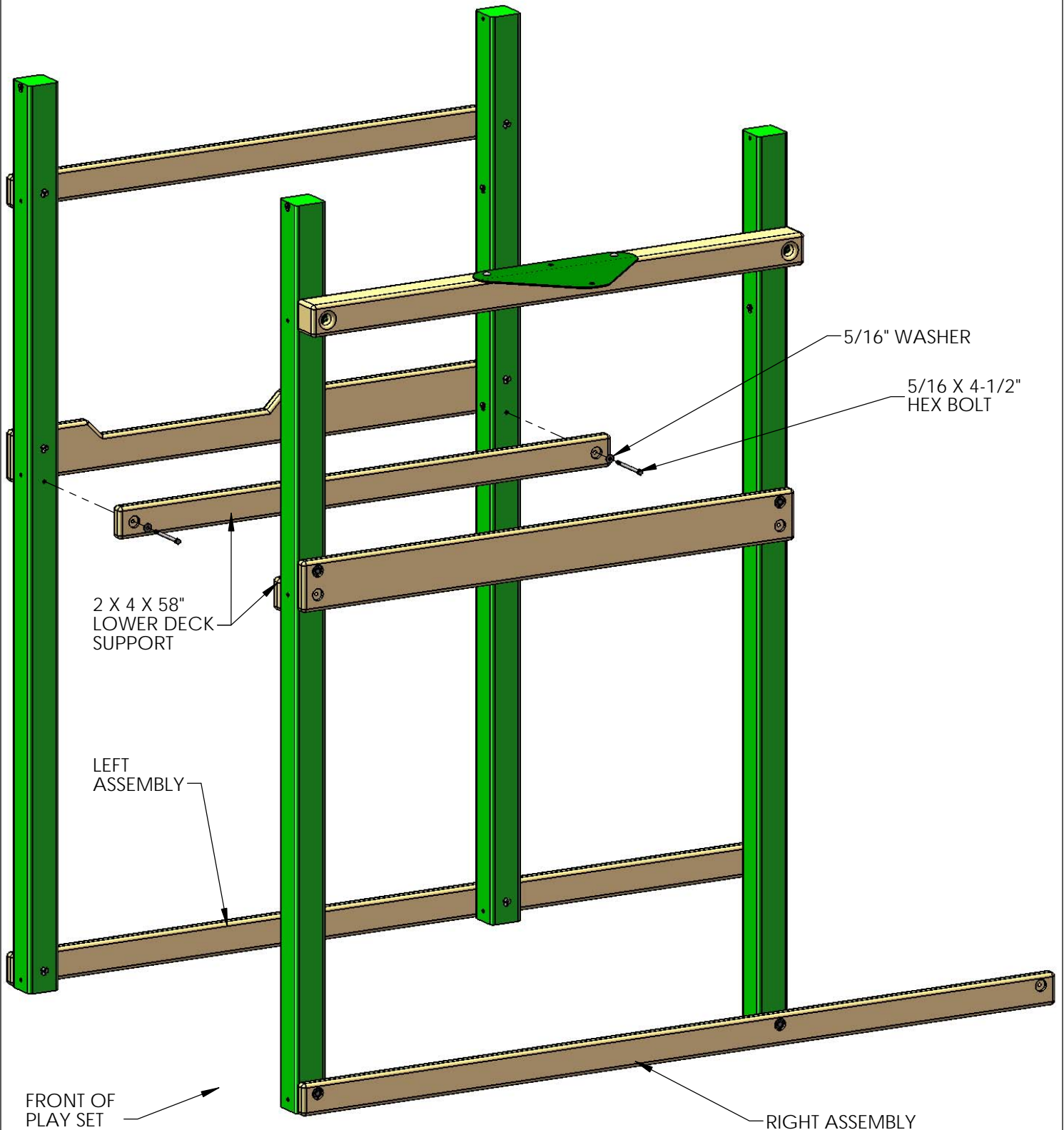



## STEP 6: LOWER DECK SUPPORTS

1: USE THE HELP OF A SECOND PERSON, OR PROP EACH SIDE UP IN A MANNER THAT ALLOWS THE SIDES TO COME TOGETHER FOR THE SECOND SET OF DECK SUPPORTS.

2: PLACE THE DECK SUPPORTS AGAINST THE CORNER POSTS; FLUSH TO THE BOTTOM OF THE DECK SUPPORTS MOUNTED IN THE PREVIOUS STEP.

3: USE 5/16 X 3-1/2" LAG SCREWS AND 5/16" WASHERS TO ATTACH THE DECK SUPPORTS TO THE CORNER POSTS.

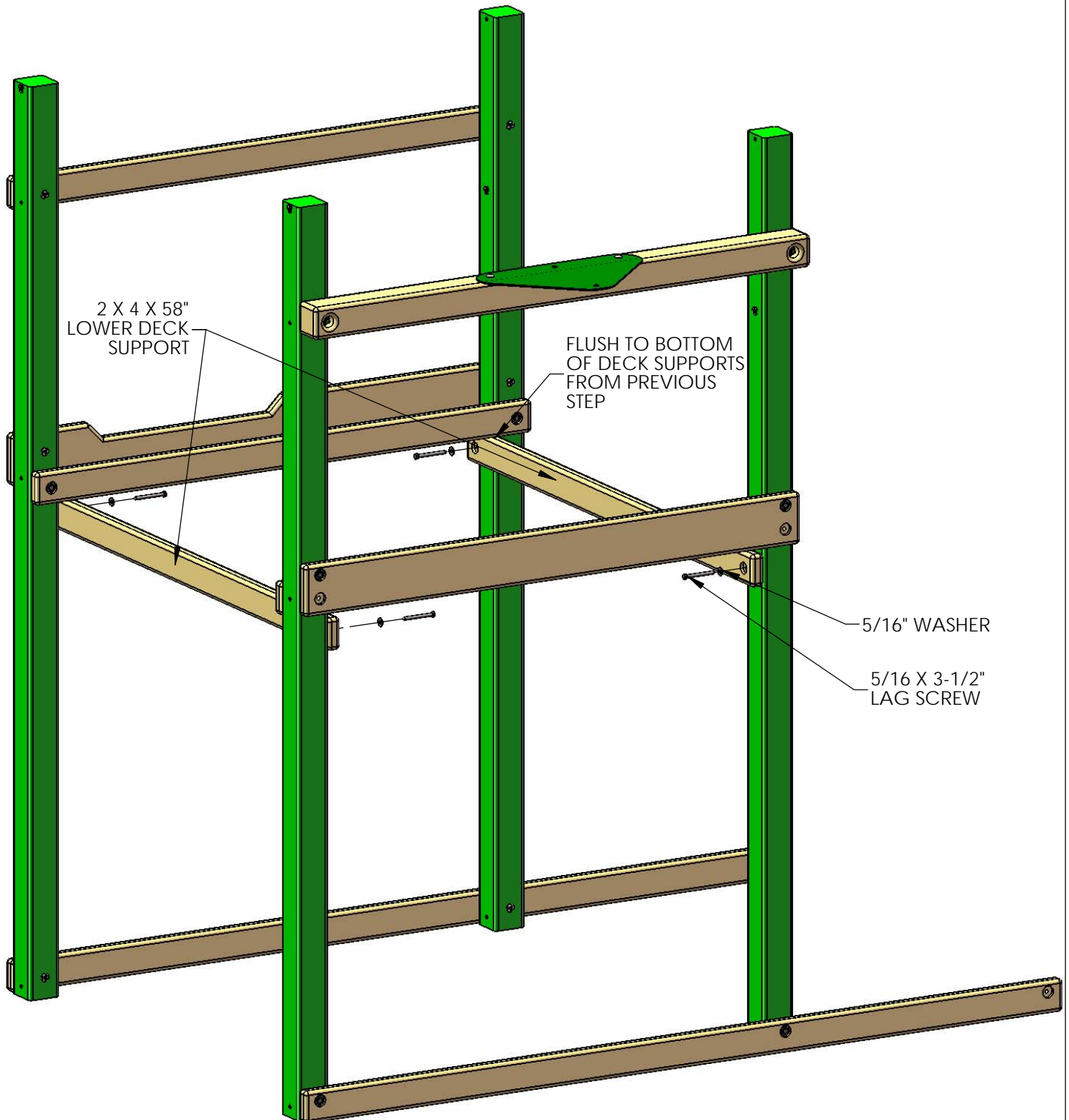

## STEP 7: FRAMING THE FRONT OF THE FORT

- 1: LAY THE 2 X 4 X 90" ROPE LADDER RUNNER AT THE FRONT OF THE FORT AT THE BOTTOM OF THE CORNER POSTS. THE OFFSET HOLES IN THE ROPE LADDER RUNNER MUST FACE DOWNWARD.
- 2: USE 5/16 X 4-1/2" HEX BOLTS AND 5/16" WASHERS TO ATTACH THE HOLES OF THE ROPE LADDER RUNNER TO THE T-NUTS INSTALLED ON THE CORNER POSTS.
- 3: LAY THE 2 X 4 X 58" BOTTOM PANEL BOARD ON THE FRONT CORNER POSTS IN THE MIDDLE OF THE CORNER POSTS. THE OFFSET HOLES IN THE BOTTOM PANEL BOARD MUST FACE DOWNWARD.
- 4: USE 5/16 X 4-1/2" HEX BOLTS AND 5/16" WASHERS TO ATTACH THE HOLES OF THE BOTTOM PANEL BOARD TO THE T-NUTS INSTALLED ON THE CORNER POSTS.
- 5: LAY THE 2 X 6 X 90" ROPE LADDER SUPPORT ON THE FRONT CORNER POSTS.
- 6: USE 5/16 X 4-1/2" HEX BOLTS AND 5/16" WASHERS TO ATTACH THE BOTTOM HOLES OF THE ROPE LADDER SUPPORT TO THE T-NUTS INSTALLED ON THE CORNER POSTS.
- 7: DO NOT INSTALL LAG SCREWS AT THIS TIME.

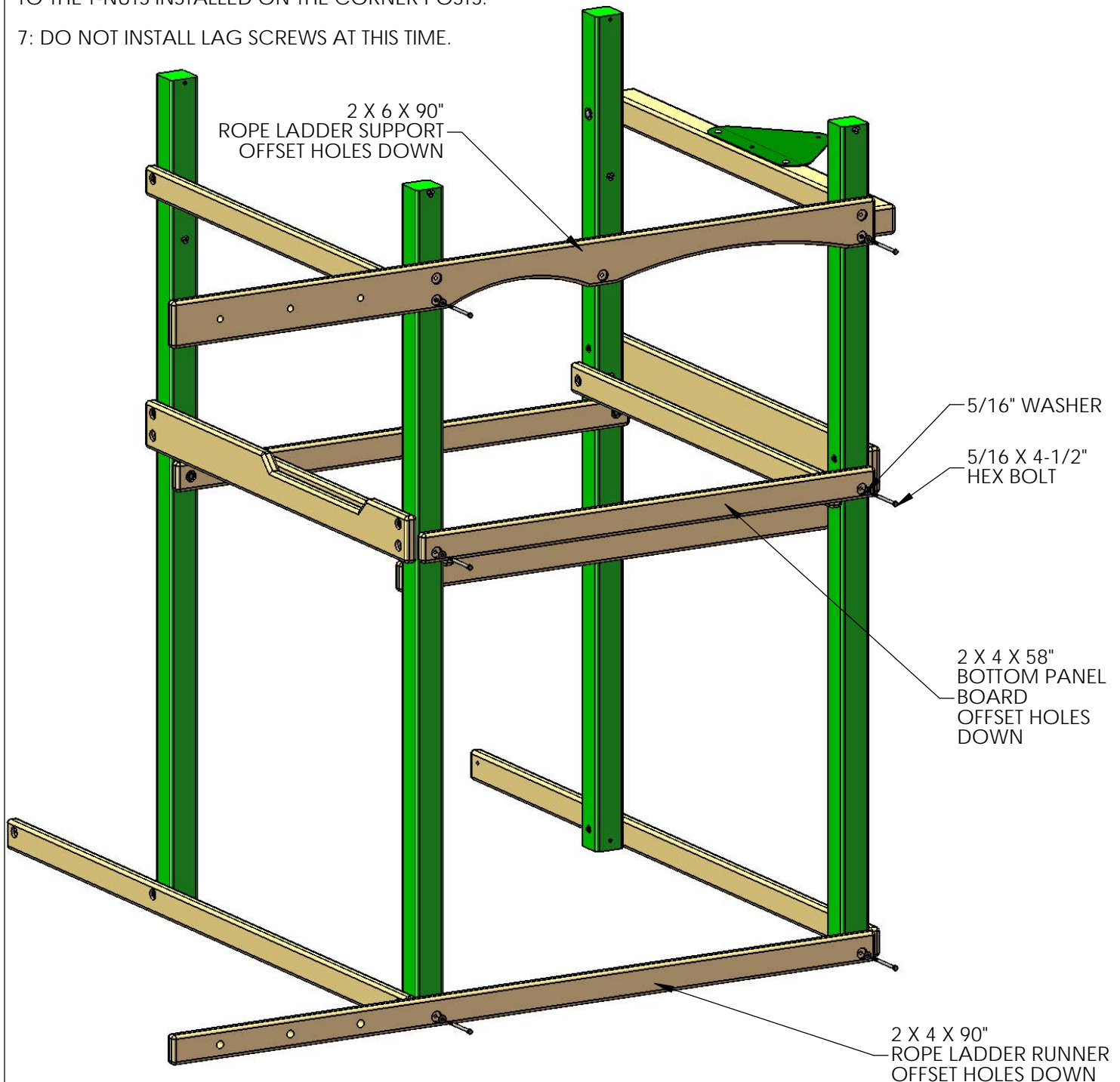

## STEP 8: FRAMING THE REAR OF THE FORT

1: LAY THE 2 X 6 X 58" REAR BOTTOM PANEL BOARD AGAINST THE REAR OF THE FORT AT THE MIDDLE OF THE CORNER POSTS. THE OFFSET HOLES IN THE REAR BOTTOM PANEL BOARD MUST FACE DOWNWARD.

2: USE 5/16 X 4-1/2" HEX BOLTS AND 5/16" WASHERS TO ATTACH THE BOTTOM HOLES OF THE REAR BOTTOM PANEL BOARD TO THE T-NUTS INSTALLED ON THE CORNER POSTS.

3: LAY THE 2 X 4 X 58" SANDBOX BOARD ON THE REAR CORNER POSTS AT THE BOTTOM OF THE CORNER POSTS ON THE INSIDE OF THE FORT. THE OFFSET HOLES IN THE SANDBOX BOARD MUST FACE DOWNWARD.

4: USE 5/16 X 4-1/2" HEX BOLTS AND 5/16" WASHERS TO ATTACH THE HOLES OF THE SANDBOX BOARD TO THE T-NUTS INSTALLED ON THE CORNER POSTS.

5: DO NOT INSTALL LAG SCREWS AT THIS TIME.

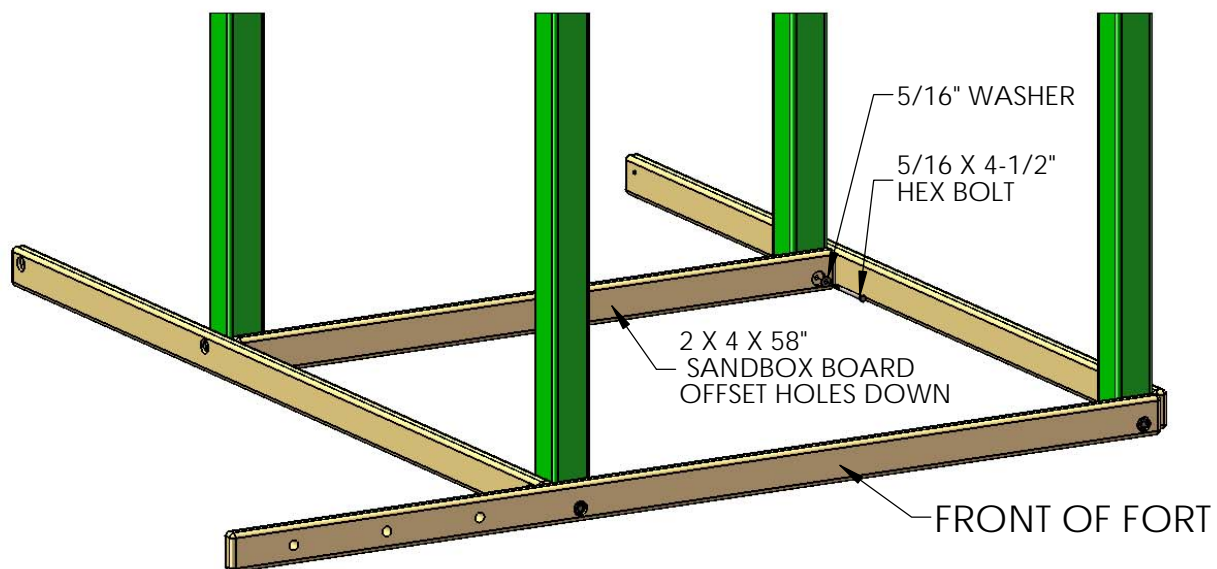
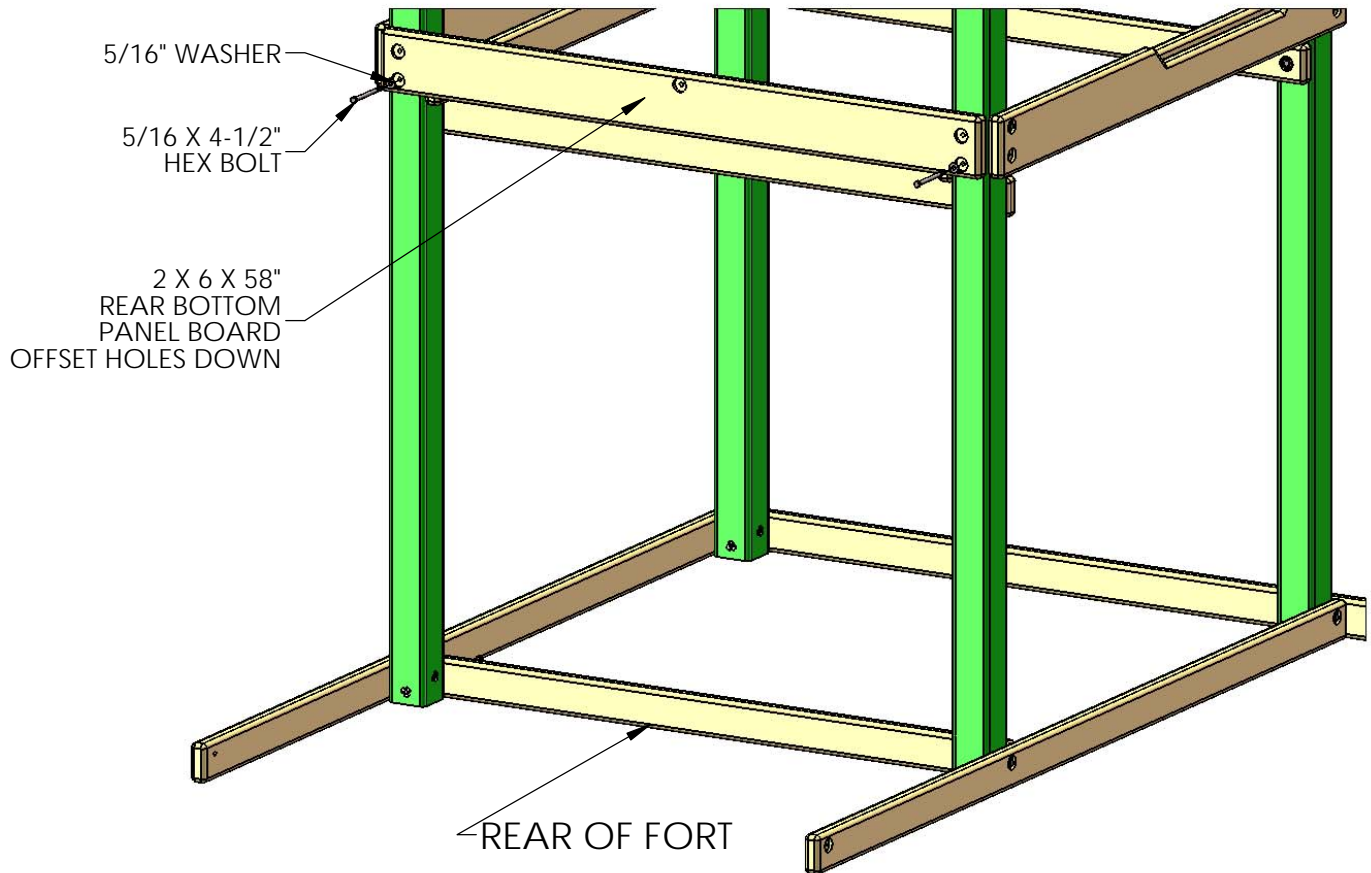

## STEP 9: LAG SCREWS

1: PLACE THE FRAME IN ITS FINAL POSITION AND FOLLOW THE PROCEDURES AT THE FRONT OF THE MANUAL TO LEVEL AND SQUARE THE STRUCTURE.

2: ONCE THE FRAME IS LEVEL, SQUARE, AND SET INTO POSITION; GO BACK AND INSERT THE 5/16 X 3-1/2" LAG SCREWS AND 5/16" WASHERS IN ALL OF THE REMAINING HOLES OF THE 2 X 6 PARTS.

NOTE: THERE WILL NOT BE ANY PREDRILLED HOLES IN THE CORNER POSTS FOR THE LAG SCREWS. LAG SCREWS ARE SELF-TAPPING.

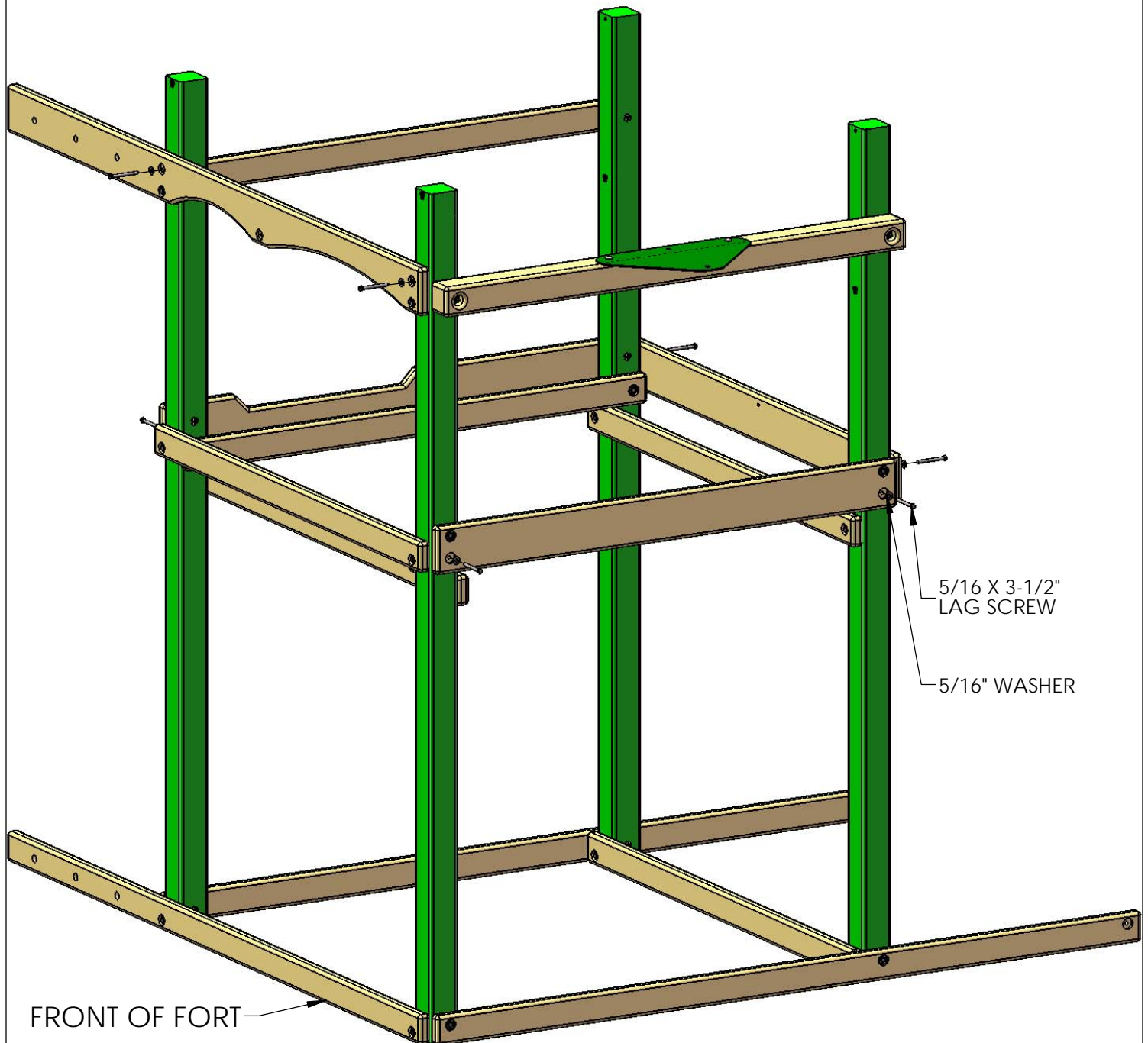

## STEP 10: LOWER DECK SUPPORTS

- 1: LAY THE TWO 2 X 4 X 58" LOWER DECK SUPPORTS ACROSS THE DECK SUPPORTS, APPROXIMATELY 19" FROM EACH SET OF CORNER POSTS.
- 2: ATTACH THE LOWER DECK SUPPORTS WITH TWO 2-1/2" WOOD SCREWS PER END.

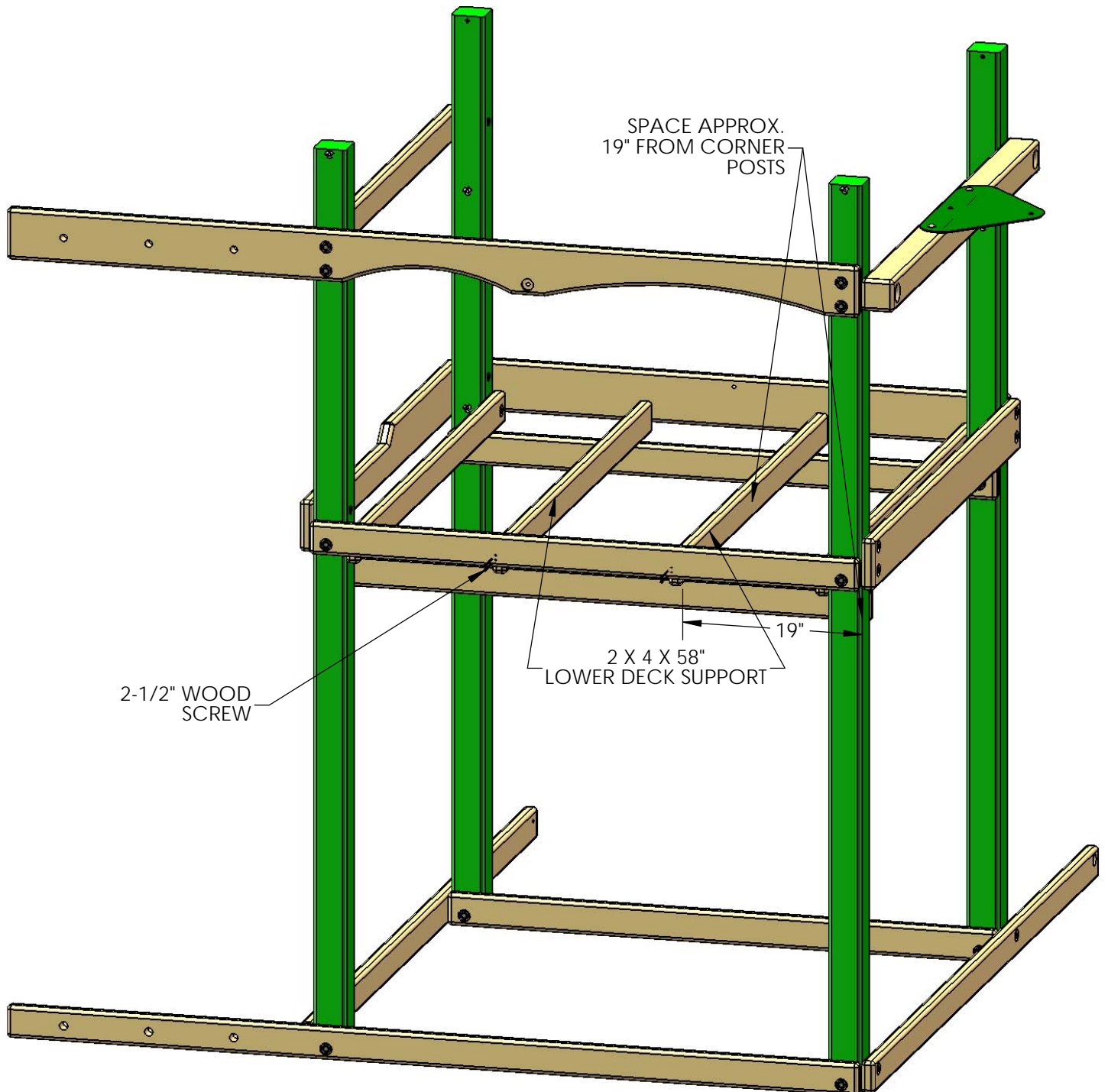

# STEP 11: DECK SPACERS

THE FOLLOWING STEP IS RECOMMENDED TO PREVENT POSSIBLE SPLITS IN THE WOOD

1: PRE-DRILL THE ENDS OF THE 5/4 X 4 X 51" DECK SPACERS TO PREVENT INSTALLATION DAMAGE. PRE-DRILL BOTH ENDS WITH A 1/8" DRILL BIT AT THE DIMENSIONS SHOWN BELOW.

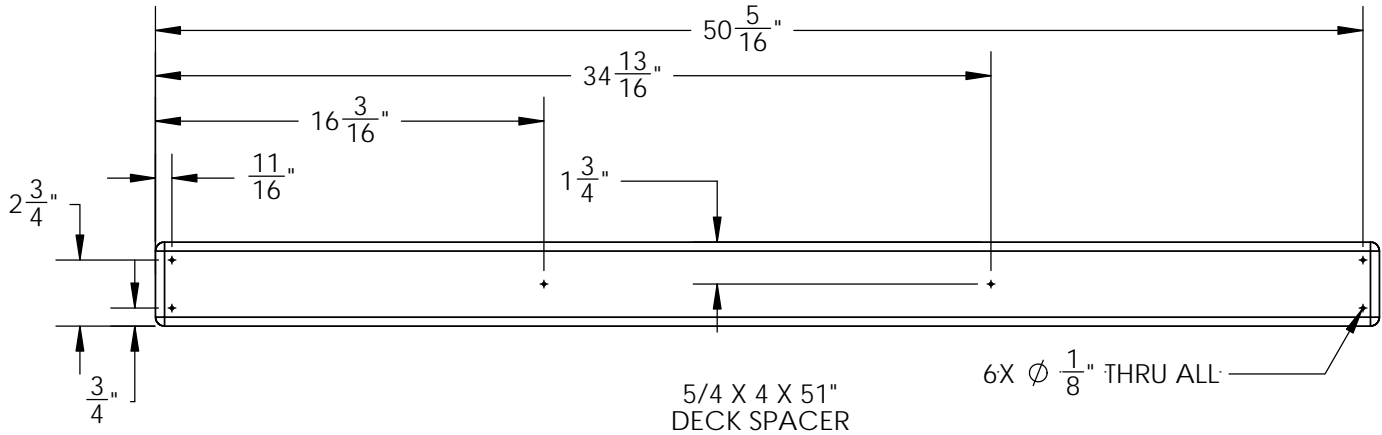

2: PLACE THE 5/4 X 4 X 51" DECK SPACER AT ONE END OF THE FORT. CENTER THE BOARD BETWEEN THE CORNER POSTS AND ATTACH IT WITH 2" WOOD SCREWS THROUGH THE PREDRILED HOLES AND INTO THE DECK SUPPORT BELOW. NOTE: THE TOP OF THE SCREW HEAD SHOULD BE FLUSH TO THE TOP OF THE DECK SPACER.

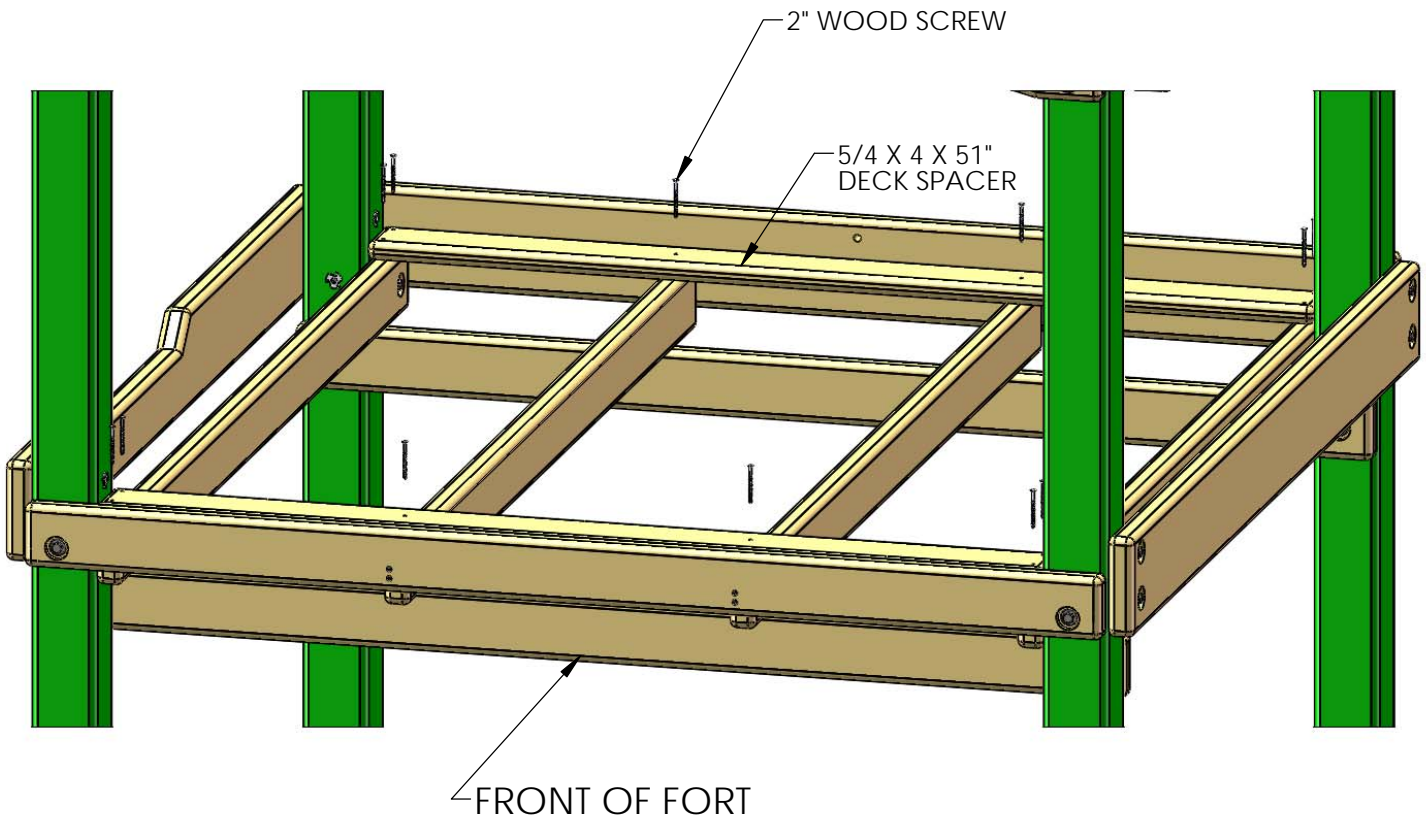

## STEP 12: DECK

THE FOLLOWING STEP IS RECOMMENDED TO PREVENT POSSIBLE SPLITS IN THE WOOD

1: PRE-DRILL THE ENDS OF THE DECK BOARDS TO PREVENT INSTALLATION DAMAGE. PRE-DRILL BOTH ENDS WITH A 1/8" DRILL BIT AT THE DIMENSIONS SHOWN BELOW.

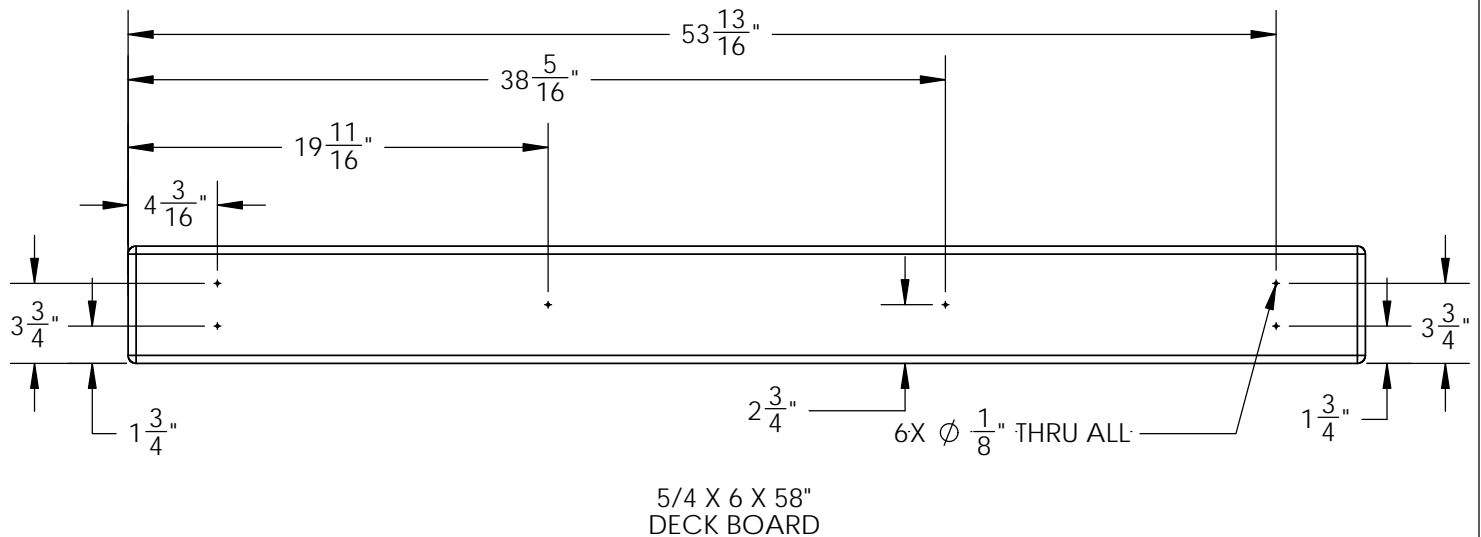

2: START WITH A 5/4 X 6 X 58" DECK BOARD AT ONE END OF THE FORT. CENTER THE BOARD BETWEEN THE SIDE FACE BOARD AND THE BOTTOM PANEL BOARD AND ATTACH IT WITH 2" WOOD SCREWS THROUGH THE PREDRILED HOLES AND INTO THE DECK SUPPORT BELOW. LEAVE A UNIFORM (APPROX. 1/4") SPACE BETWEEN THE DECK BOARDS. NOTE: THE TOP OF THE SCREW HEAD SHOULD BE FLUSH TO THE TOP OF THE DECK BOARDS.

LAY ALL DECK BOARDS ACROSS THE DECK SUPPORTS BEFORE SECURING THEM TO THE FORT. THIS WILL ENSURE THAT YOU HAVE EQUAL SPACING ACROSS THE DECK.

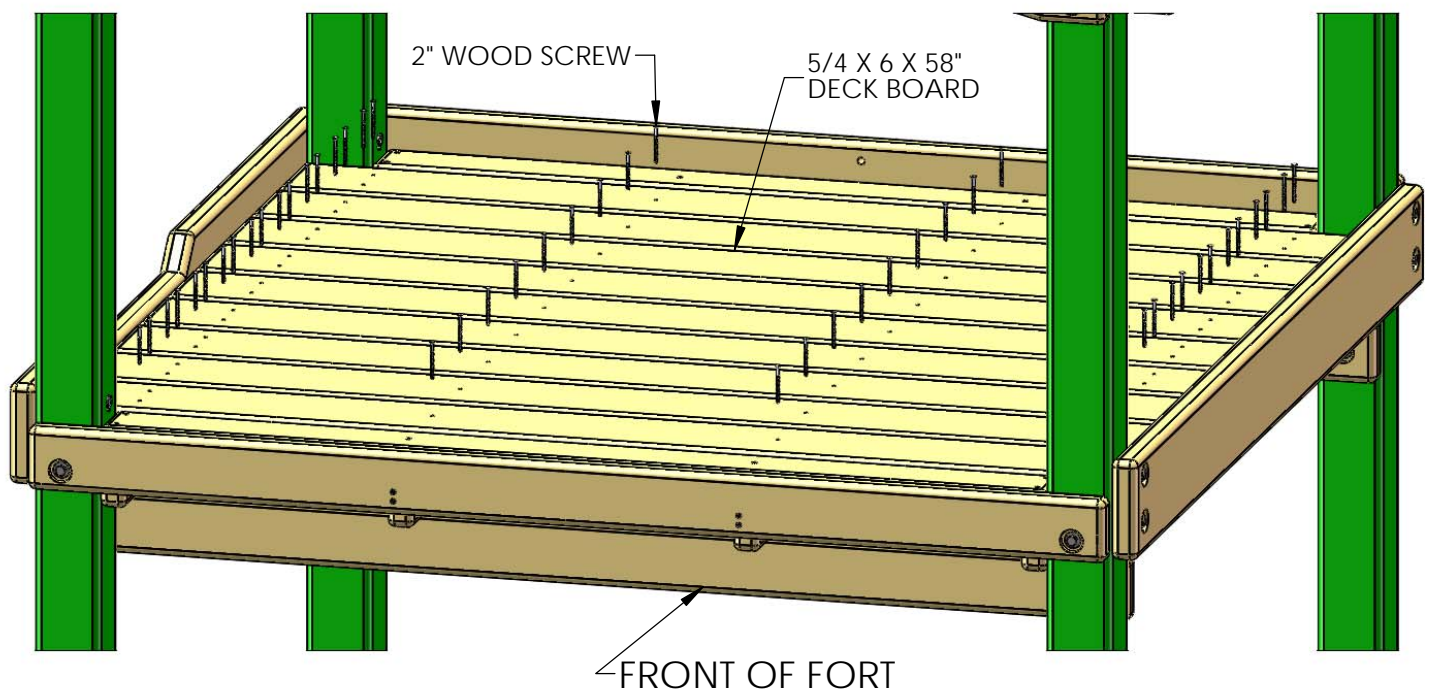

## STEP 13: LADDER

- 1: FIND TWO 2 X 4 X 66" LADDER SIDES.
- 2: POSITION THE LADDER SIDES SO THAT THE SLOTS IN THE BOARDS ARE FACING EACH OTHER AND ARE PARALLEL.
- 3: INSERT T-NUTS INTO THE OUTSIDE OF THE LADDER SIDES AND SET WITH A HAMMER.

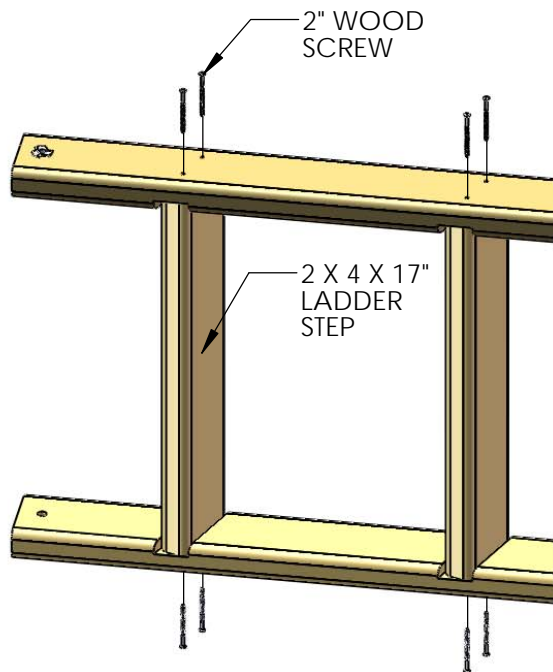
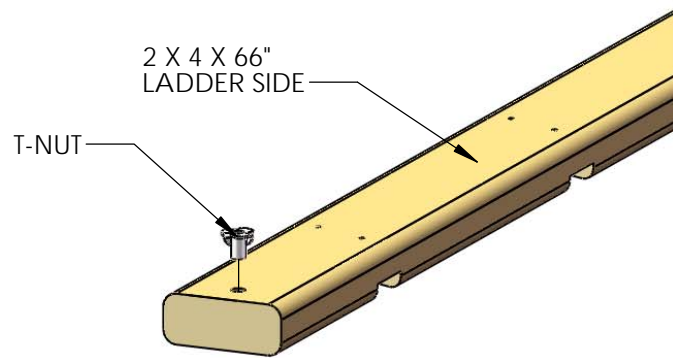

- 4: FIND FIVE 2 X 4 X 17" LADDER STEPS.

- 5: PLACE THE STEPS INTO THE SLOTS ON THE LADDER SIDES, AND FASTEN WITH 2" WOOD SCREWS.

- 6: CAREFULLY TURN THE LADDER OVER AND PUT THE SCREWS INTO THE OTHER SIDE.

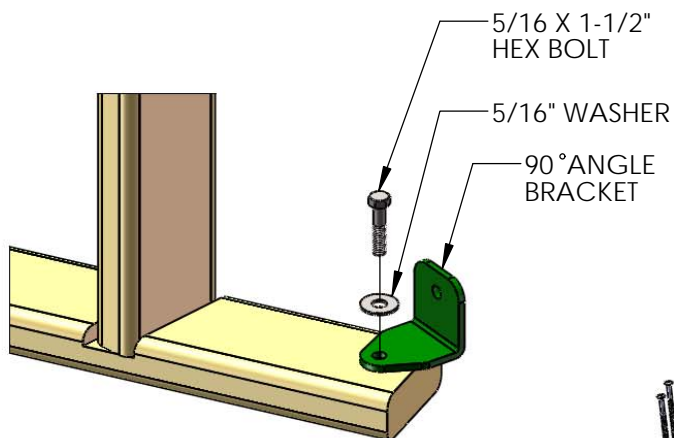

- 7: INSTALL THE 90° ANGLE BRACKETS TO THE INSIDE OF THE LADDER RAILS WITH 5/16 X 1-1/2" BOLTS, 5/16 WASHERS, INTO THE 5/16" T-NUTS.

- 8: INSTALL THE 5/4 X 3 X 18-3/4" LADDER BACK ABOVE THE TOP STEP OF THE LADDER WITH TWO 2" WOOD SCREWS PER SIDE.

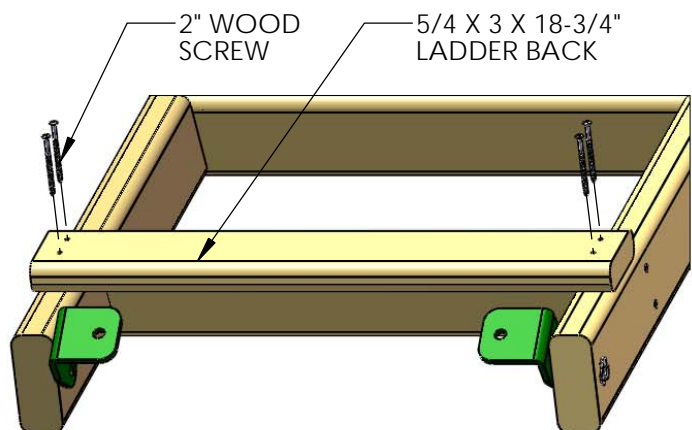



## STEP 14: ATTACHING THE LADDER TO THE FORT

1: PLACE THE LADDER INTO POSITION ON THE FORT AS SHOWN BELOW. THE SIDE OF THE LADDER SHOULD BE 2-1/2" AWAY FROM THE OUTSIDE OF THE CORNER POST AS SHOWN IN DETAIL D. ALSO EACH 90 DEGREE ANGLE BRACKET SHOULD BE LOCATED 3/4" UP FROM THE BOTTOM OF THE 2 X 4 X 58" BOTTOM PANEL BOARD. USING THE 90 DEGREE ANGLE BRACKETS AS A TEMPLATE, DRILL A 3/8" HOLE THROUGH THE BOTTOM PANEL BOARD.

2: FROM THE UNDERSIDE OF THE DECK INSERT A T-NUT INTO THE BACKSIDE OF THE 3/8" HOLES ON THE BOTTOM PANEL BOARD.

3: ATTACH THE LADDER WITH 5/16 X 1-1/2" HEX BOLTS AND 5/16" WASHERS.

4: WHEN THE BRACKETS ARE SECURE, AND THE LADDER IS IN ITS FINAL POSITION; TIGHTEN THE 5/16 X 1-1/2" BOLTS ON THE LADDER SIDES.

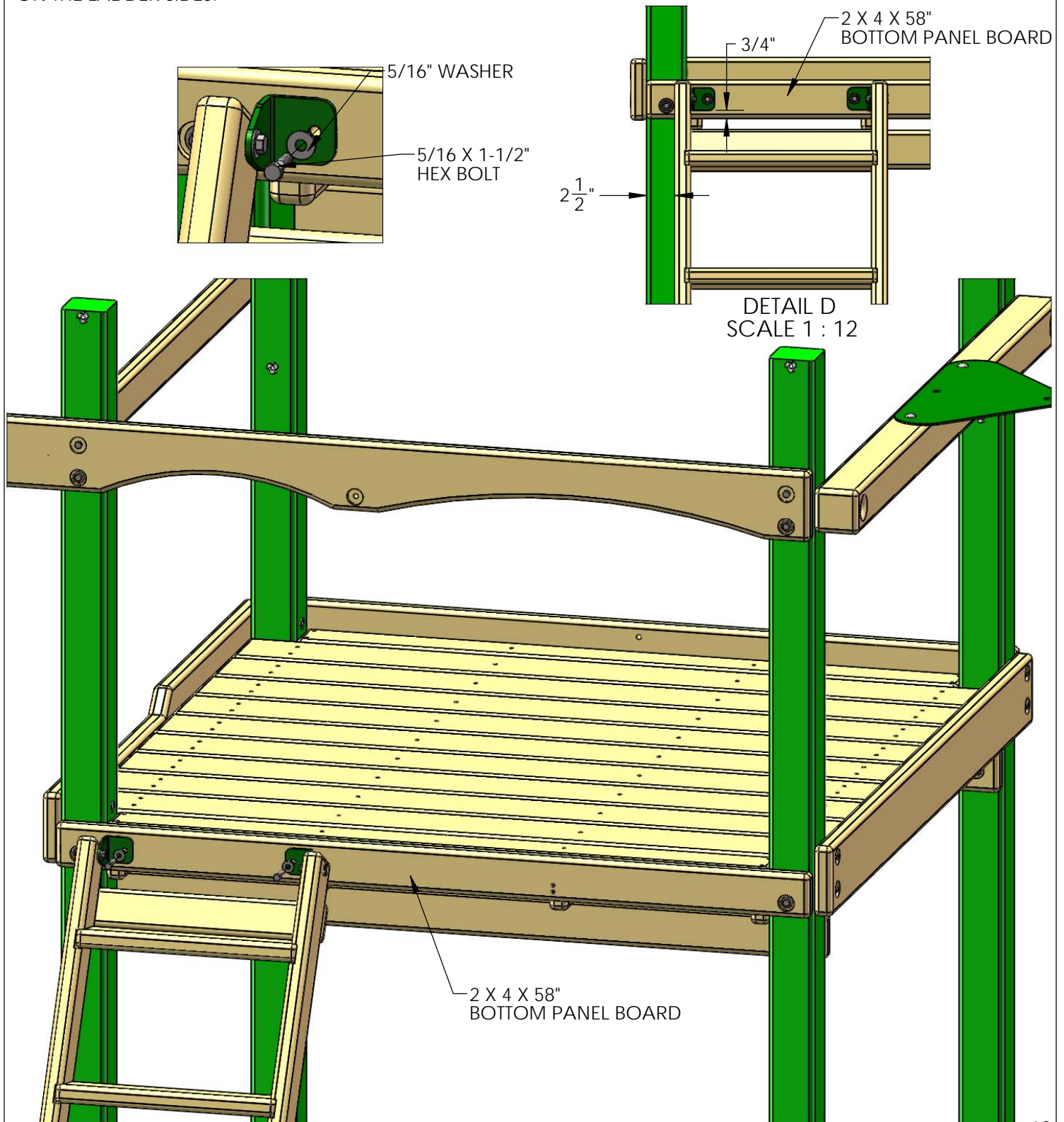

# STEP 15: ANGLE BRACES

1: MAKE SURE THE FORT IS LEVEL AND SQUARE.

2: THE FOUR 2 X 4 X 13" ANGLE SUPPORTS ARE MOUNTED TO THE LOWER DECK SUPPORTS UNDER THE DECK ON THE FRONT AND BACK OF THE FORT.

3: USE TWO 2-1/2" WOOD SCREWS AT THE TOP OF THE BRACE, AND ONE 2" AND ONE 3" WOOD SCREW TO FASTEN THE ANGLE SUPPORTS TO THE CORNER POSTS.

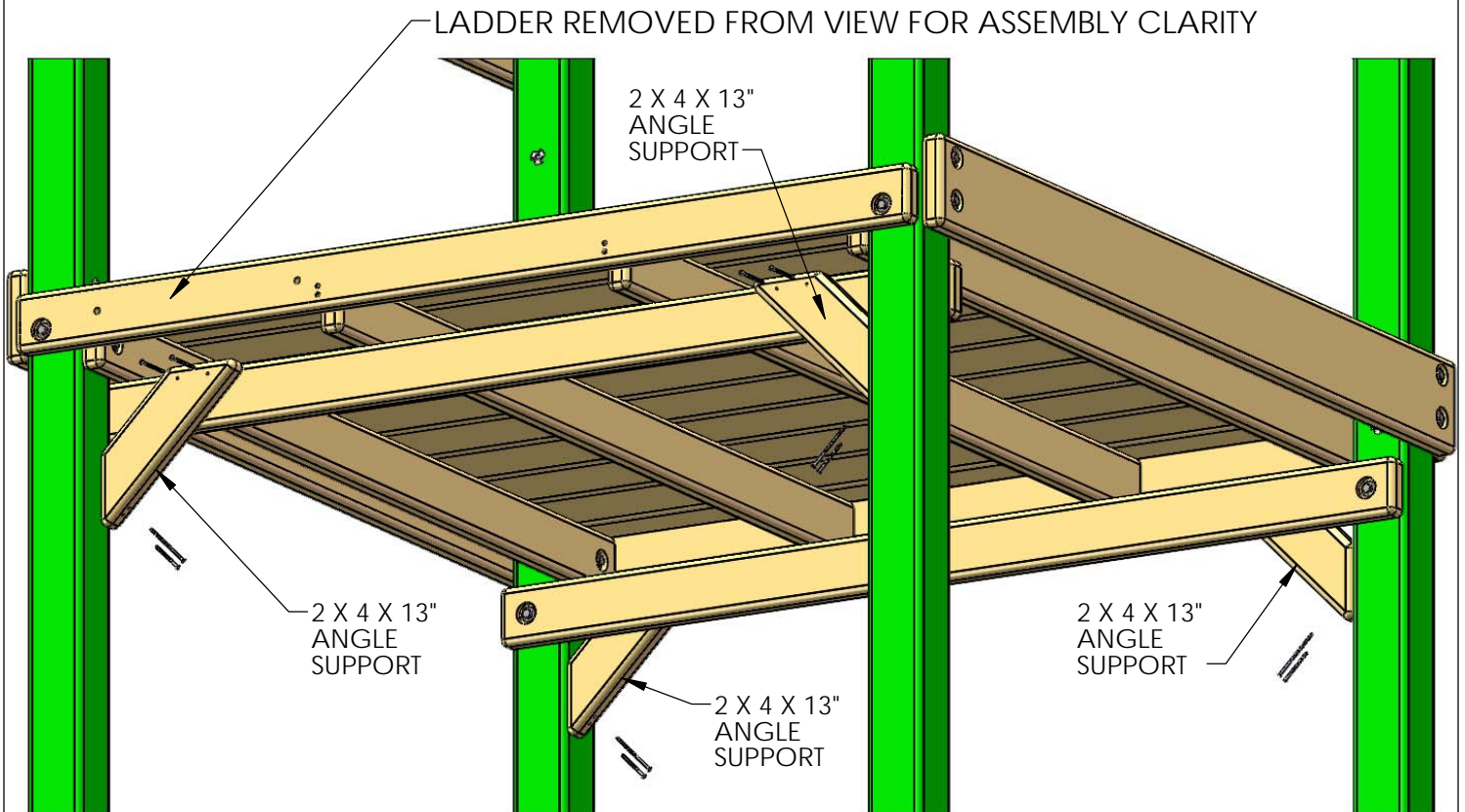
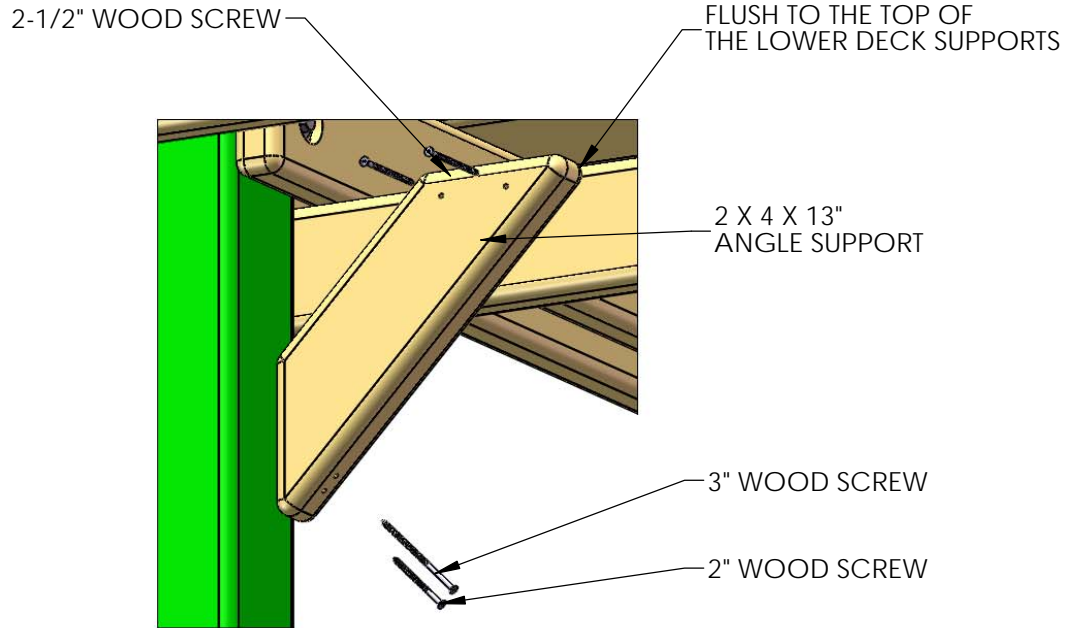

FRONT OF FORT

## STEP 16: ANGLE BRACES

1: THE FOUR 2 X 4 X 18" ANGLE SUPPORTS ARE MOUNTED UNDER THE DECK ON THE LEFT AND RIGHT SIDES OF THE FORT.

2: USE TWO 2-1/2" WOOD SCREWS ON TOP OF THE BRACE, AND ONE 2" AND ONE 3" WOOD SCREW TO FASTEN THE ANGLE SUPPORTS TO THE CORNER POSTS.

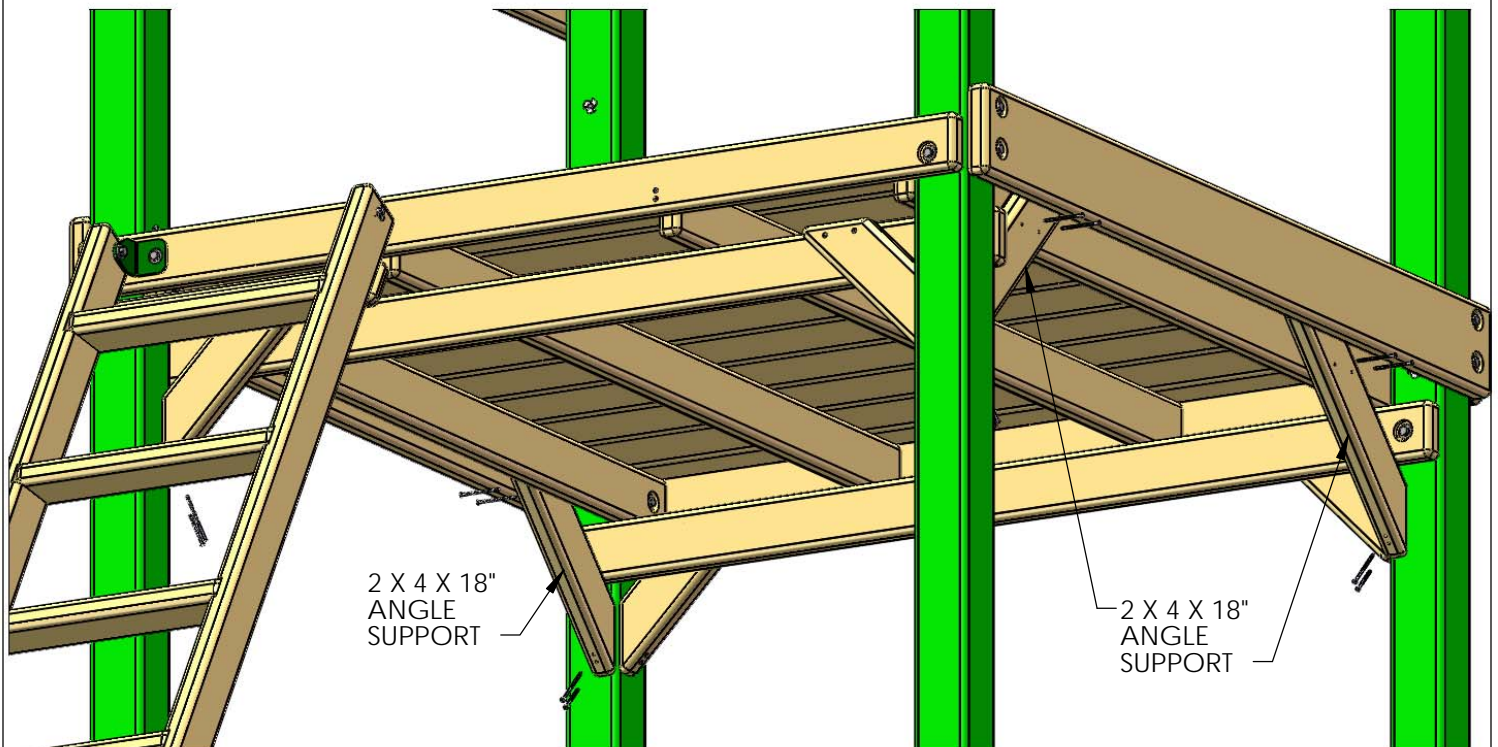
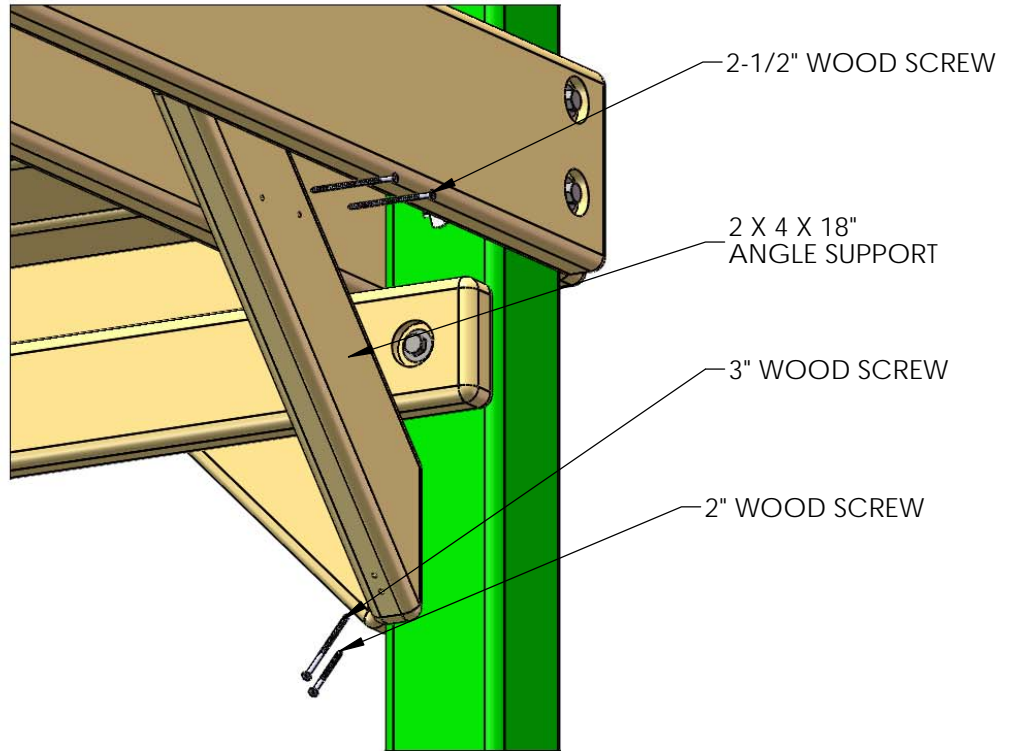

FRONT OF FORT

## STEP 17: ROCK WALL

- 1: FIND TWO 2 X 4 X 66" ROCK WALL SIDES.
- 2: POSITION THE ROCK WALL SIDES SO THAT THE HOLES IN THE BOARDS ARE BOTH FACING THE SAME WAY.
- 3: INSERT T-NUTS INTO THE INSIDE OF THE ROCK WALL SIDES AND SET WITH A HAMMER.

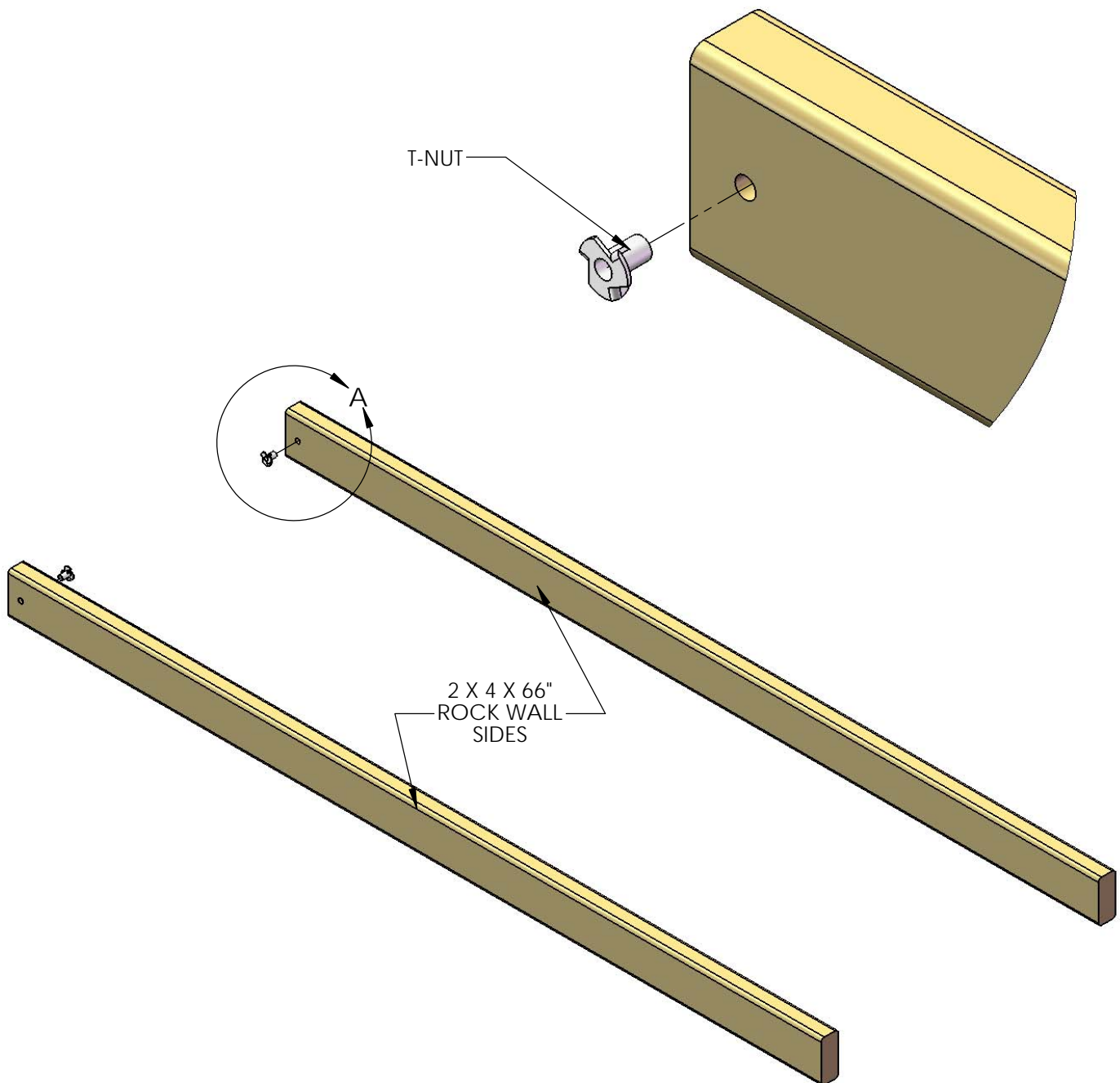

## STEP 18: ROCK WALL

- 1: FIND ELEVEN 5/4 X 6 X 23-7/8" ROCK WALL BOARDS, AND ONE 5/4 X 6 X 23-7/8" BOTTOM ROCK WALL BOARD(1 HOLE).
- 2: STARTING FROM THE TOP, PLACE ONE ROCK WALL BOARD ON TOP OF THE ROCK WALL SIDES, FLUSH TO THE TOP OF THE ROCK WALL SIDES, AND ATTACH WITH TWO 2" WOOD SCREWS IN EACH SIDE.
- 3: CONTINUE DOWN THE ROCK WALL WITH THE REMAINING ROCK WALL BOARDS, FASTENING EACH BOARD WITH TWO 2" WOOD SCREWS ON EACH END.
- 4: THE FINAL BOARD WILL BE THE BOTTOM ROCK WALL BOARD WITH ONE HOLE. ATTACH WITH TWO 2" WOOD SCREWS PER SIDE.
- 5: IN SOME CASES, THERE WILL BE EXCESS LENGTH ON THE ROCK WALL SIDES. THIS IS DUE TO MILLING VARIATIONS, AND IS ALSO USED TO HELP LEVEL THE ROCK WALL SIDES ON UNEVEN GROUND.
- 6: ROCK WALL SIDES MAY NOT BE EVEN WITH THE BOTTOM ROCK WALL BOARD DUE TO MILLING VARIATIONS AND WOOD SHRINKAGE.

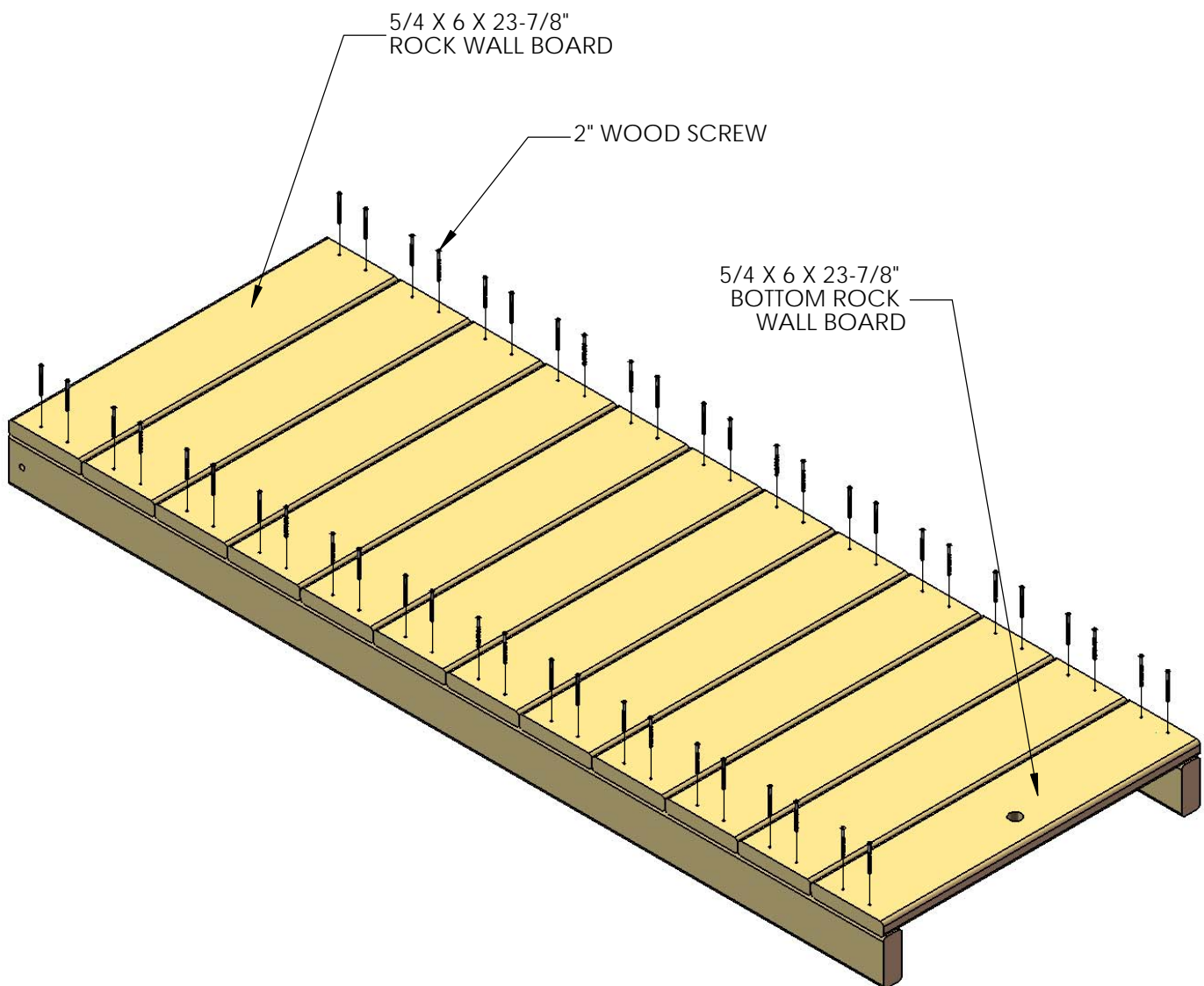

## STEP 19: ROCK WALL

1: FASTEN THE 90° GREEN BRACKET TO THE ROCK WALL SIDES WITH 5/16 X 1-1/2" HEX BOLTS AND 5/16" WASHERS.

2: DO NOT FULLY TIGHTEN THE HEX BOLTS INTO THE T-NUTS AT THIS TIME.

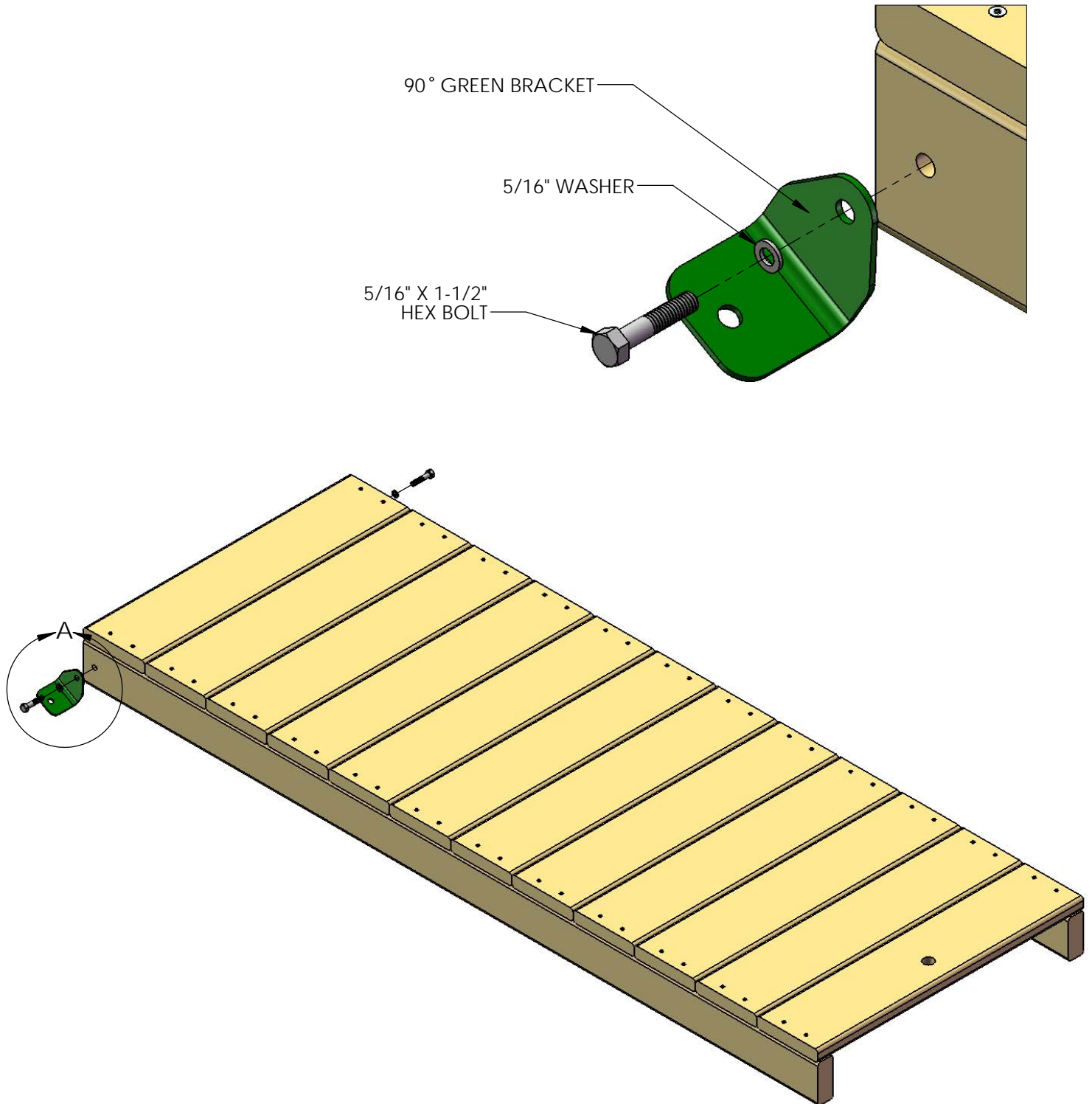

## STEP 20: ROCK WALL

1: FIND TEN ROCKS AND THIRTY 1-1/4" PAN HEAD SCREWS WITH WASHERS INCLUDED WITH THE ROCKS.

2: MOUNT THE ROCKS IN A STAGGERED MANNER ON THE ROCK WALL BOARDS. THREE PAN HEAD SCREWS AND WASHERS WILL SECURE EACH ROCK TO THE WALL.

NOTE: THE IMAGE SHOWN BELOW IS A GENERIC ARRANGEMENT OF ROCKS ON THE ROCK WALL. YOUR ACTUAL CONFIGURATION MAY BE DIFFERENT THAT WHAT YOU SEE BELOW. ROCKS CAN BE ARRANGED IN ANY PATTERN AS LONG AS THEY WILL ALLOW PROPER ACCESS TO THE FORT. BE CREATIVE!

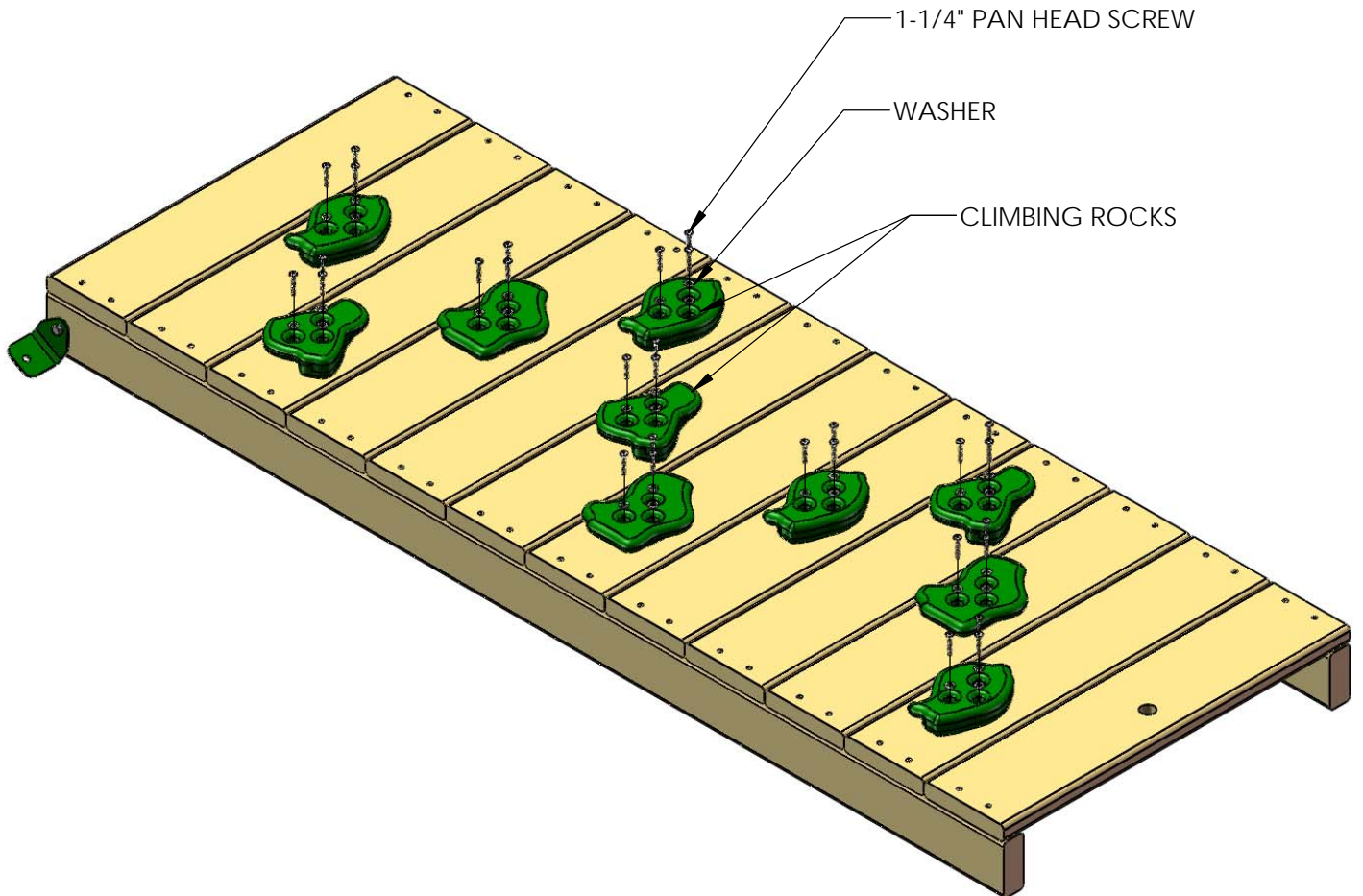

3: PLACE THE 5/4 X 3 X 23-7/8" ROCK WALL TOP CAP ON TOP OF THE ROCK WALL SIDES. FASTEN THE ROCK WALL TOP CAP TO THE ROCK WALL SIDES WITH 2" WOOD SCREWS.

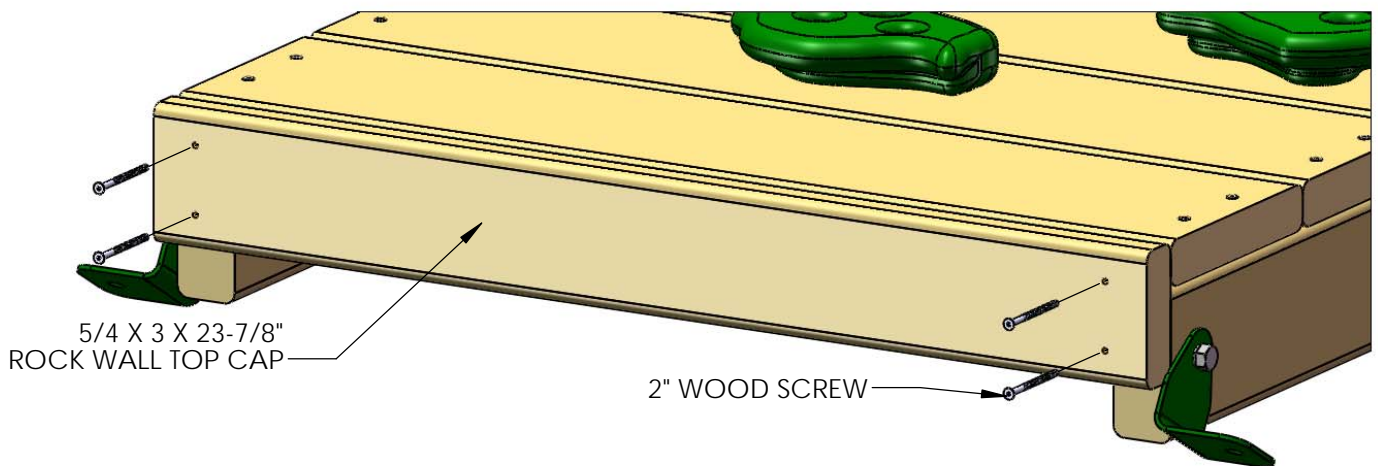

## STEP 21: ATTACHING THE ROCK WALL

1: PLACE THE ROCK WALL INTO POSITION ON THE FORT AS SHOWN BELOW. USING THE 90° BRACKETS AS A TEMPLATE; DRILL A 3/8" HOLE THROUGH THE SIDE FACE BOARD. THE BOTTOM OF THE GREEN BRACKETS SHOULD BE APPROXIMATELY 3/4" FROM THE BOTTOM OF THE SIDE FACE BOARD.

2: FROM THE UNDERSIDE OF THE DECK INSERT A T-NUT INTO THE BACKSIDE OF THE 3/8" HOLES ON THE SIDE FACE BOARD.

3: ATTACH THE ROCK WALL WITH 5/16 X 1-1/2" BOLTS AND 5/16" WASHERS.

4: WHEN THE BRACKETS ARE SECURE, AND THE ROCK WALL IS IN ITS FINAL POSITION; TIGHTEN THE 5/16 X 1-1/2" BOLTS ON THE ROCK WALL SIDES.

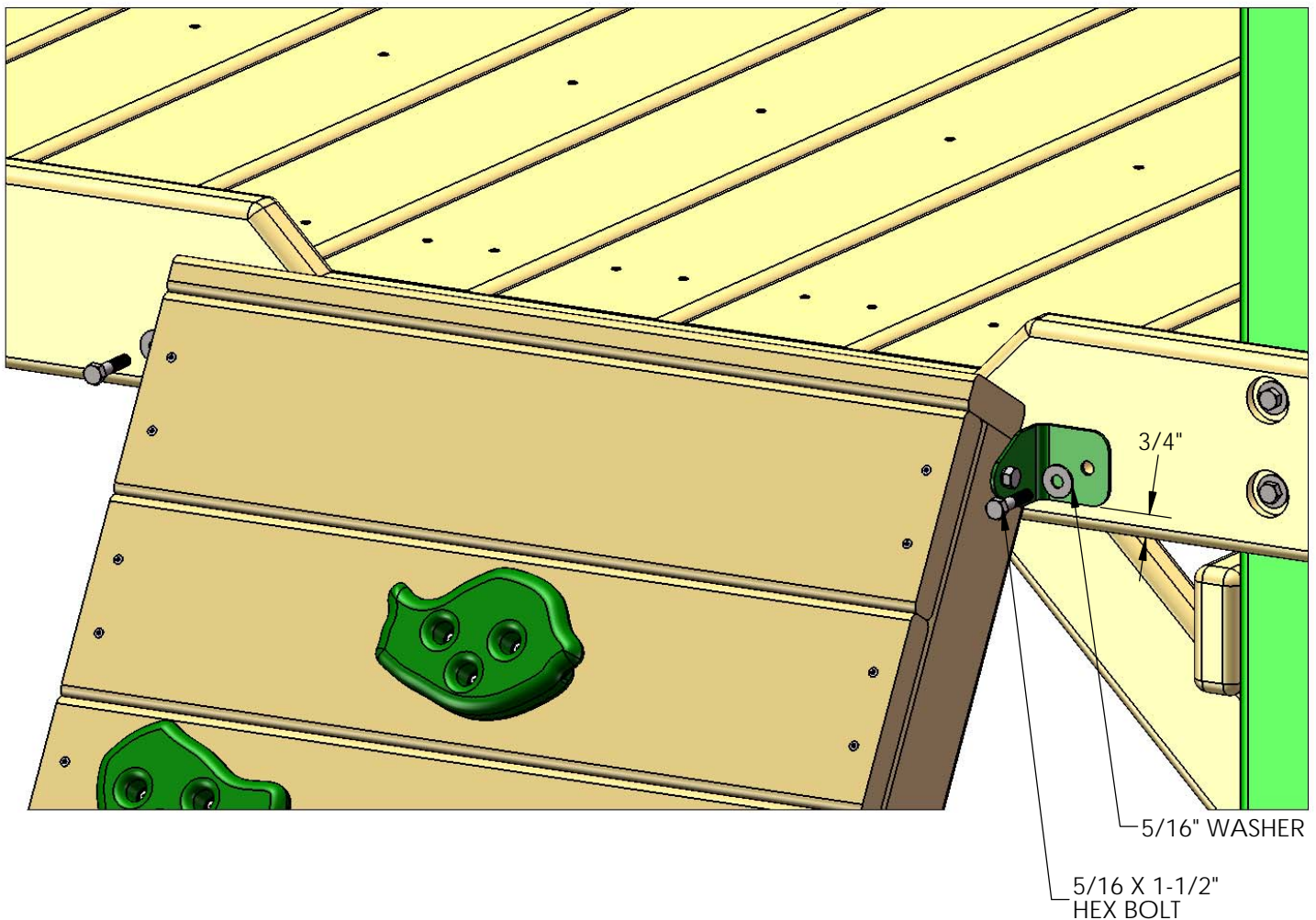



## STEP 22: UPPER LEVEL DECK SUPPORT

- 1: THE REAR OF THE FORT WILL HAVE ONE 2 X 4 X 58" UPPER LEVEL DECK SUPPORT (3 HOLES ON CENTER) AT THE HOLES 77-1/2" FROM THE GROUND
- 2: USE 5/16 X 4-1/2" HEX BOLTS AND 5/16" WASHERS TO ATTACH THE HOLES OF THE UPPER LEVEL DECK SUPPORT TO THE T-NUTS INSTALLED ON THE CORNER POSTS.
- 3: THE MIDDLE HOLE WILL NOT BE USED AT THIS TIME.

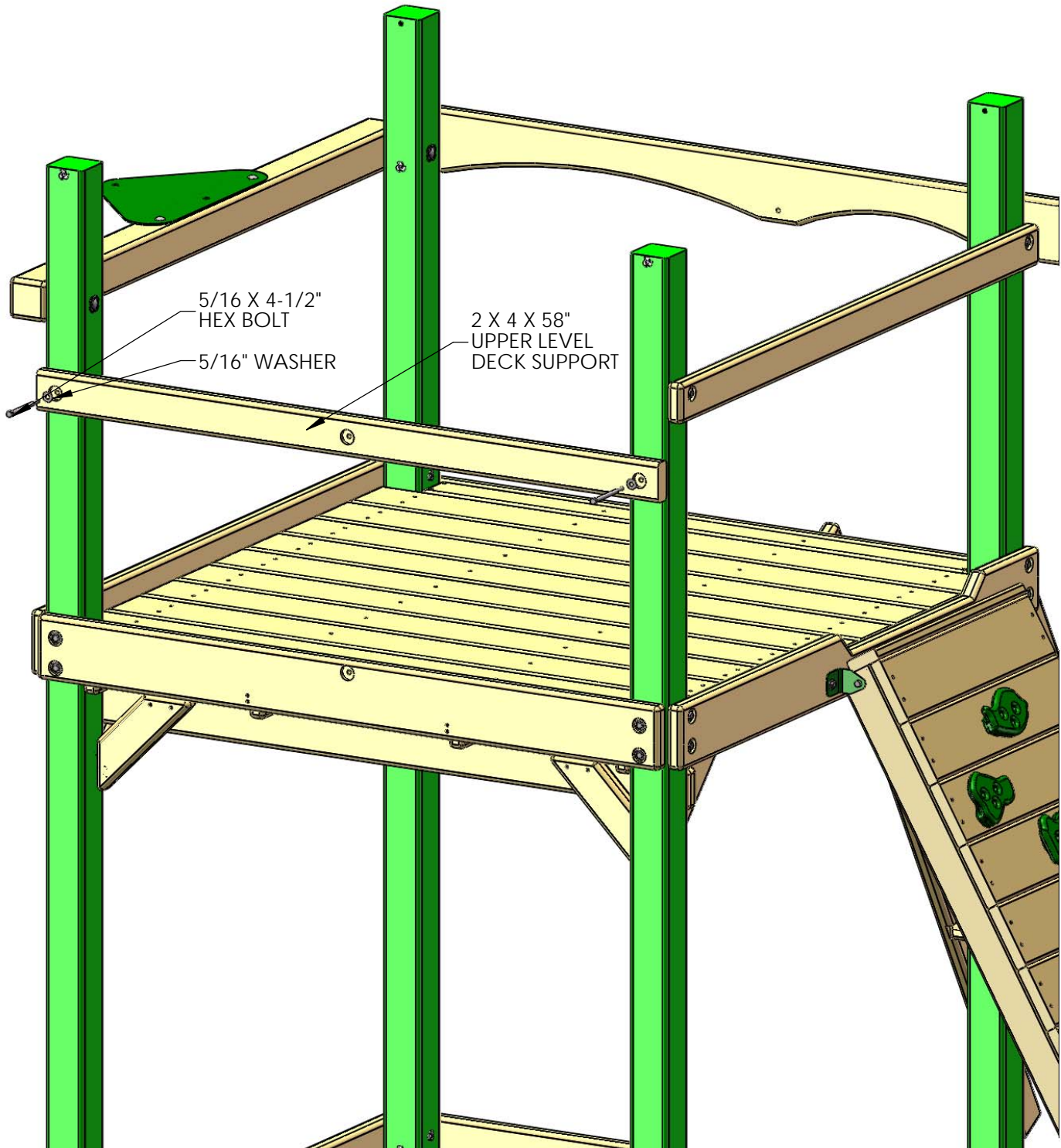

REAR OF FORT

## STEP 23: UPPER LEVEL DECK STEPS

- 1: TWO 2 X 4 X 58" PT SUPPORT/UPPER LEVEL STEP BOARDS WILL BE USED TO ENTER THE UPPER LEVEL FROM THE LOWER LEVEL.
- 2: THE FIRST BOARD WILL MOUNT ABOVE THE REAR BOTTOM PANEL BOARD, WITH APPROXIMATELY A 3-1/2" GAP BETWEEN THE FIRST STEP AND THE REAR BOTTOM PANEL BOARD.
- 3: SECURE WITH THREE 2-1/2" WOOD SCREWS IN EACH END, INTO THE CORNER POSTS.
- 4: THE SECOND BOARD WILL MOUNT IN THE SAME MANNER, ABOVE THE PREVIOUSLY INSTALLED STEP, WITH APPROXIMATELY A 3-1/2" GAP BETWEEN THE BOARDS.
- 5: SECURE WITH THREE 2-1/2" WOOD SCREWS IN EACH END, INTO THE CORNER POSTS.

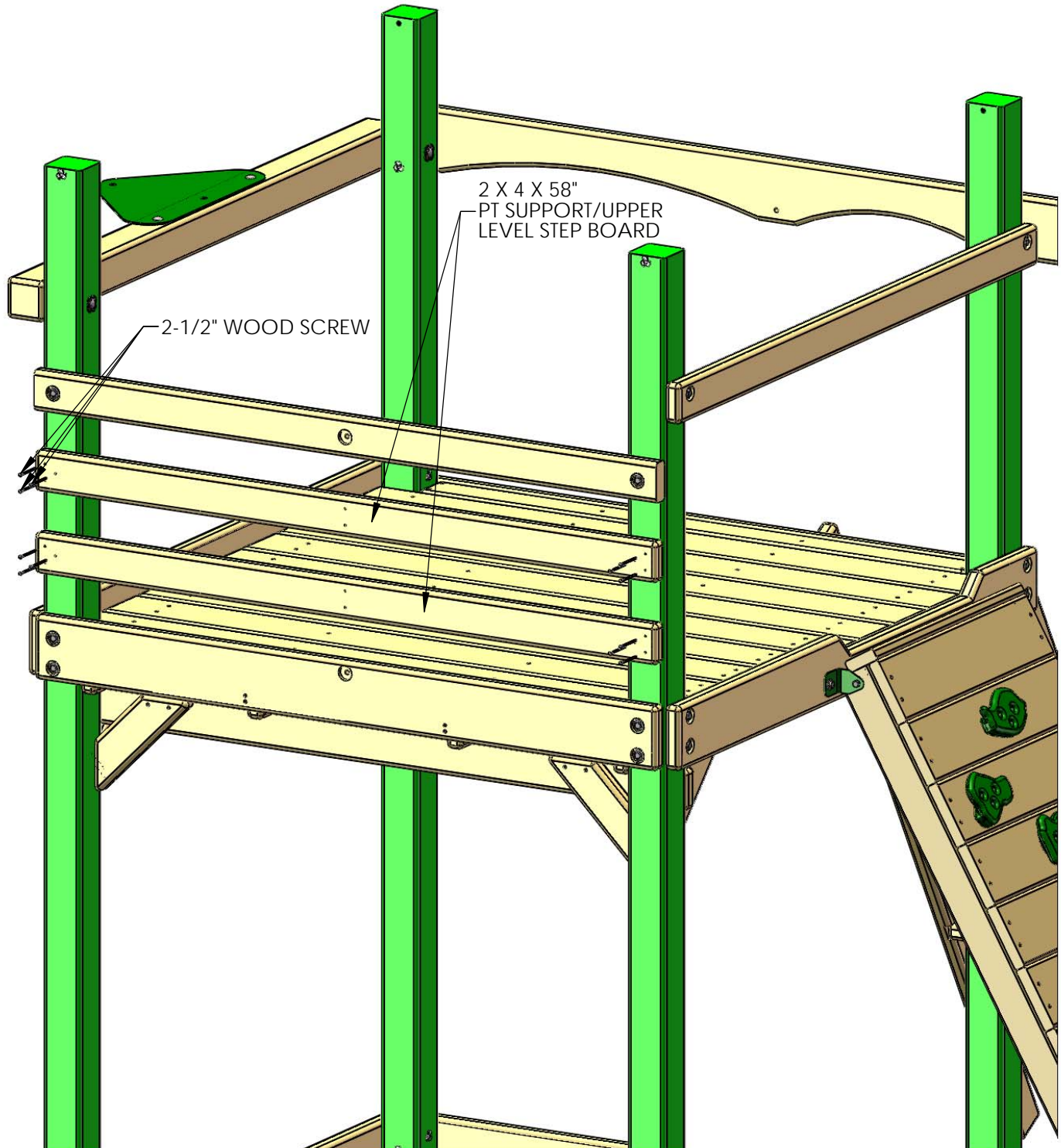

REAR OF FORT

## STEP 24: LOWER LEVEL FRONT CENTER POST

- 1: FIND THE 4 X 4 X 31" LOWER LEVEL FRONT CENTER POST, AND POSITION IT SO THAT IT RESTS ON THE DECK AT THE FRONT OF THE FORT, CENTERED ON THE OPEN HOLE OF THE 2 X 6 ROPE LADDER SUPPORT. THE SIDE OF THE FRONT CENTER POST SHOULD BE 29-3/4" FROM THE INSIDE OF THE CORNER POST AS SHOWN BELOW.
- 2: USING THE HOLE IN THE ROPE LADDER SUPPORT AS A TEMPLATE, DRILL A 3/8" HOLE THROUGH THE LOWER LEVEL FRONT CENTER POST.
- 3: INSTALL A T-NUT INTO THE HOLE YOU JUST DRILLED FROM THE INSIDE OF THE FORT.
- 4: USE A 5/16 X 4-1/2" HEX BOLT WITH A 5/16" WASHER FROM THE OUTSIDE OF THE ROPE LADDER SUPPORT TO FASTEN THE LOWER LEVEL FRONT CENTER POST TO THE ROPE LADDER SUPPORT.
- 5: MAKE SURE THE LOWER LEVEL FRONT CENTER POST IS SQUARE TO THE DECK.
- 6: FROM UNDERNEATH THE FORT; USE THREE 3" WOOD SCREWS TO FASTEN THE LOWER LEVEL FRONT CENTER POST TO THE DECK.

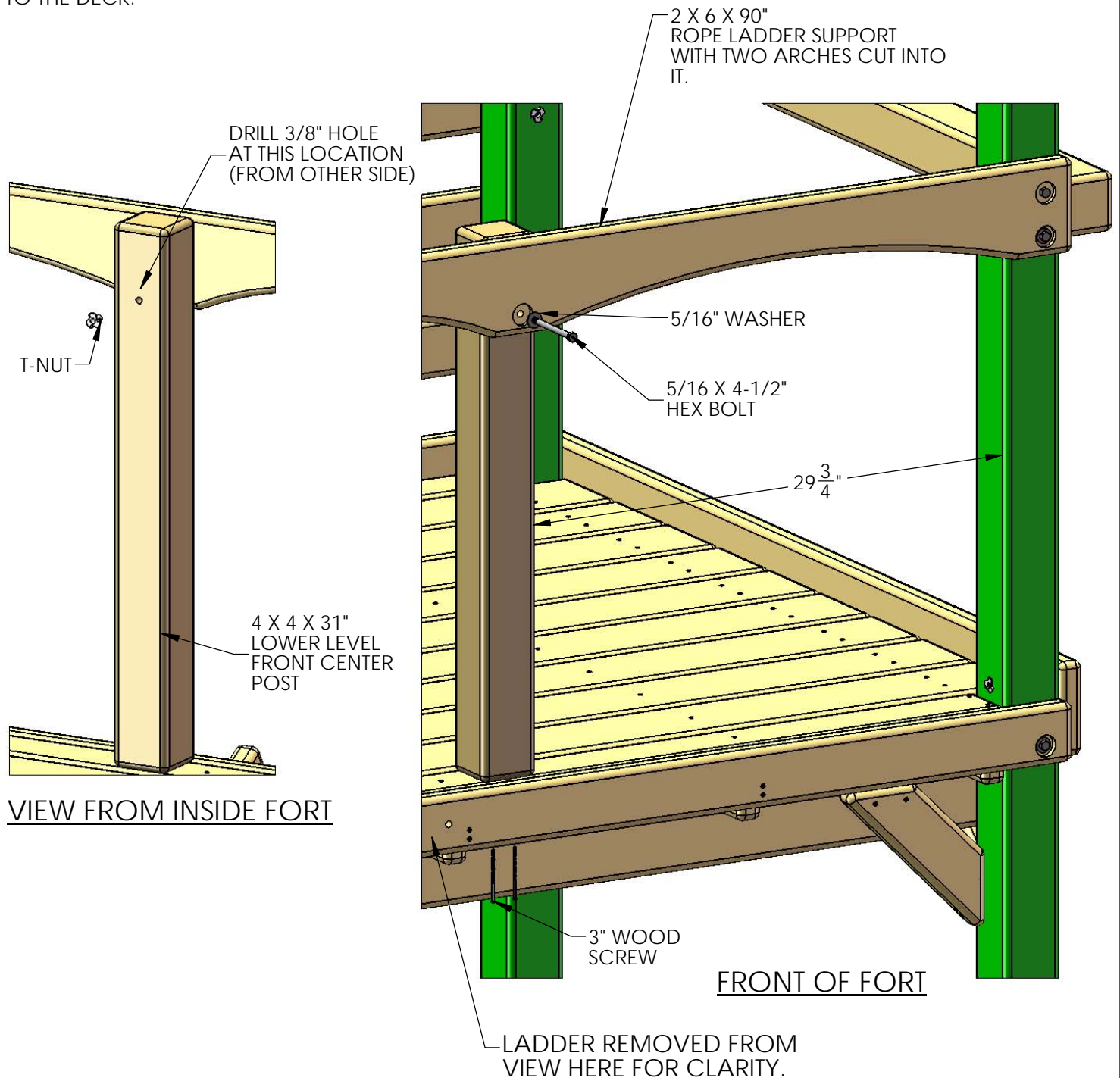

## STEP 25: LOWER LEVEL REAR CENTER POST

1: FIND THE 2 X 4 X 60-1/8" LOWER LEVEL REAR CENTER POST, AND POSITION IT SO THAT IT RESTS ON THE DECK AT THE REAR OF THE FORT, CENTERED ON THE OPEN HOLES OF THE 2 X 6 REAR BOTTOM PANEL BOARD AND THE 2 X 4 UPPER LEVEL DECK SUPPORT.

2: INSTALL A T-NUT INTO THE HOLE OF THE LOWER LEVEL REAR CENTER POST FROM THE INSIDE OF THE FORT.

3: USE A 5/16 X 2-1/4" HEX BOLT WITH A 5/16" WASHER FROM THE OUTSIDE OF THE REAR BOTTOM PANEL BOARD, AND THE UPPER LEVEL DECK SUPPORT TO FASTEN THE LOWER LEVEL REAR CENTER POST TO THE FORT.

4: MAKE THE LOWER LEVEL REAR CENTER POST SQUARE TO THE UPPER LEVEL DECK SUPPORT. USING THE HOLE IN THE UPPER LEVEL DECK SUPPORT AS A TEMPLATE, DRILL A 3/8" HOLE IN THE LOWER LEVEL REAR CENTER POST. INSTALL A T-NUT IN THE HOLE FROM THE INSIDE OF THE FORT.

5: ATTACH THE LOWER LEVEL REAR CENTER POST TO THE UPPER LEVEL STEPS WITH TWO 2-1/2" WOOD SCREWS PER BOARD.

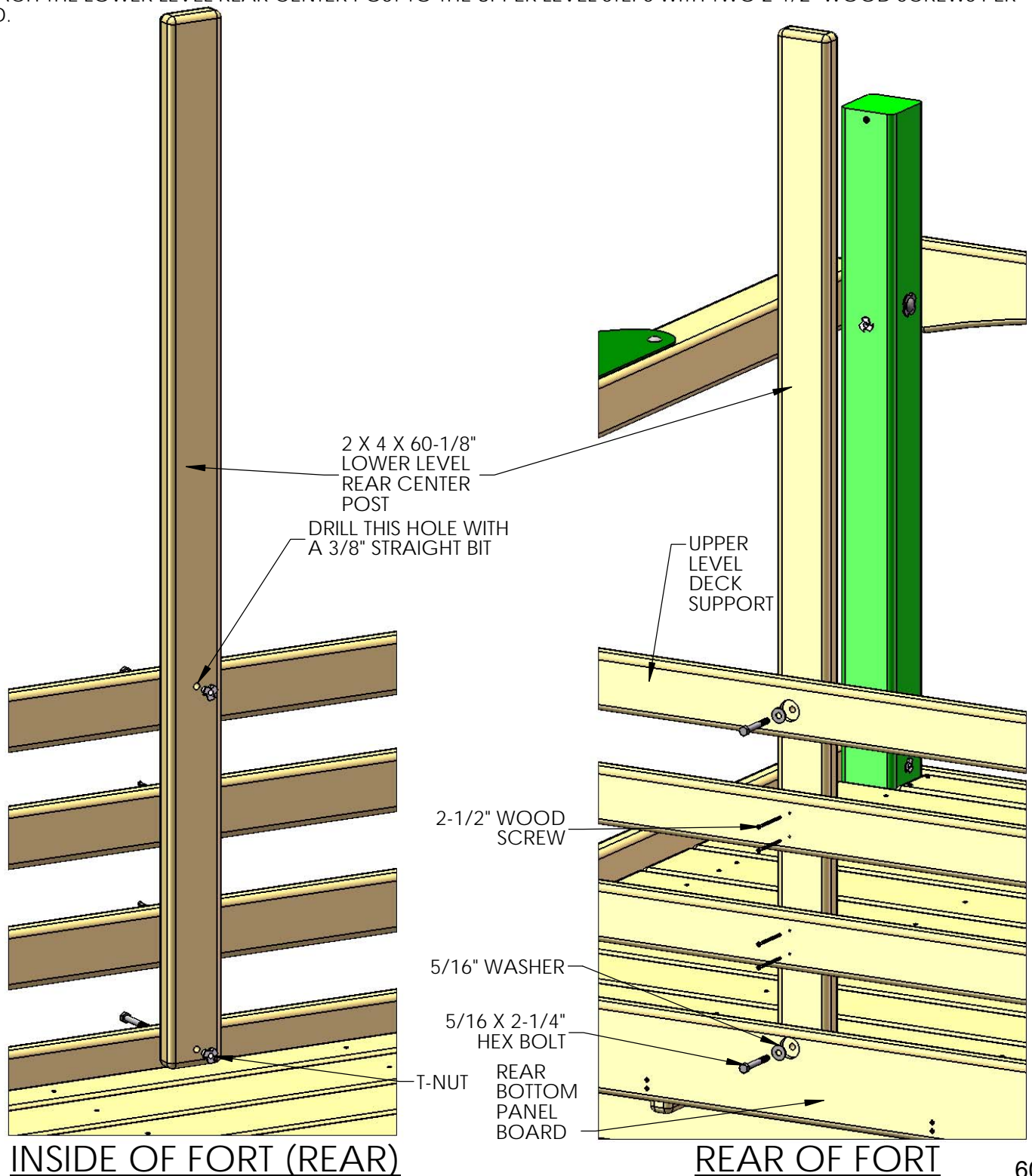

## STEP 26: PICNIC TABLE SUPPORTS

- 1: MEASURE AND MARK THE HEIGHT FOR THE PICNIC TABLE SUPPORTS (RECOMMENDED HEIGHTS ARE 14" AND 24").
- 2: SECURE THE 2 X 4 X 58": PICNIC TABLE SUPPORTS TO THE CORNER POSTS WITH SIX 2-1/2" WOOD SCREWS, THREE ON EACH END.

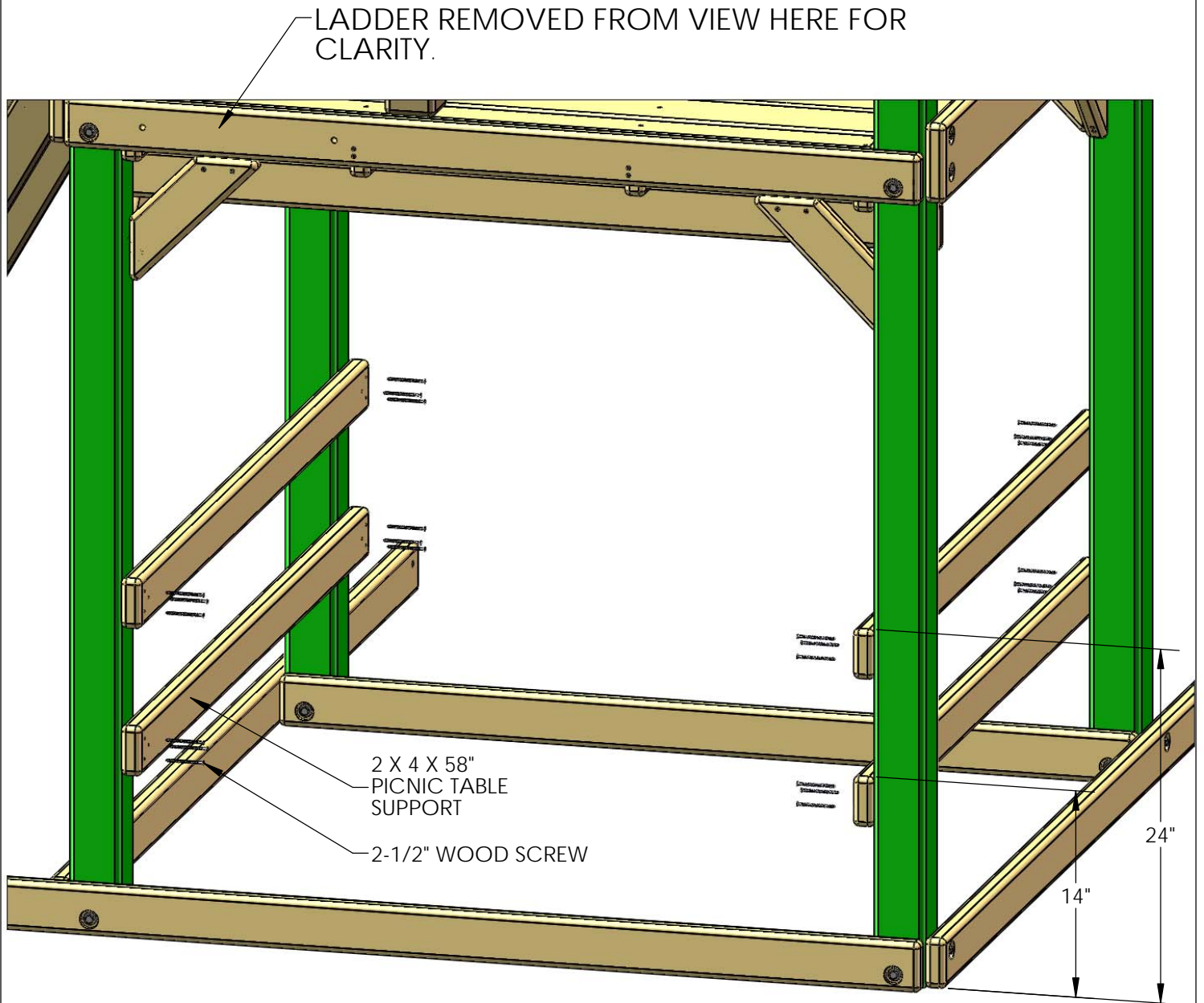

FRONT OF FORT

## STEP 27: PICNIC TABLE TOP AND SEATS

- 1: THE 2 X 6 X 58" PICNIC TABLE SEATS WILL LAY ACROSS THE LOWER PICNIC TABLE SUPPORTS FLUSH TO EITHER END OF THE CORNER POSTS.
- 2: SECURE THE PICNIC TABLE SEATS TO THE LOWER PICNIC TABLE SUPPORTS WITH FOUR 2-1/2" WOOD SCREWS (TWO PER END).
- 3: PLACE FOUR 2 X 6 X 58" PICNIC TABLE TOP BOARDS ON THE CENTER OF THE UPPER PICNIC TABLE SUPPORTS.
- 4: SECURE THE PICNIC TABLE TOP BOARDS TO THE UPPER PICNIC TABLE SUPPORTS WITH FOUR 2-1/2" WOOD SCREWS (TWO PER END).

LADDER REMOVED FROM VIEW HERE FOR CLARITY.

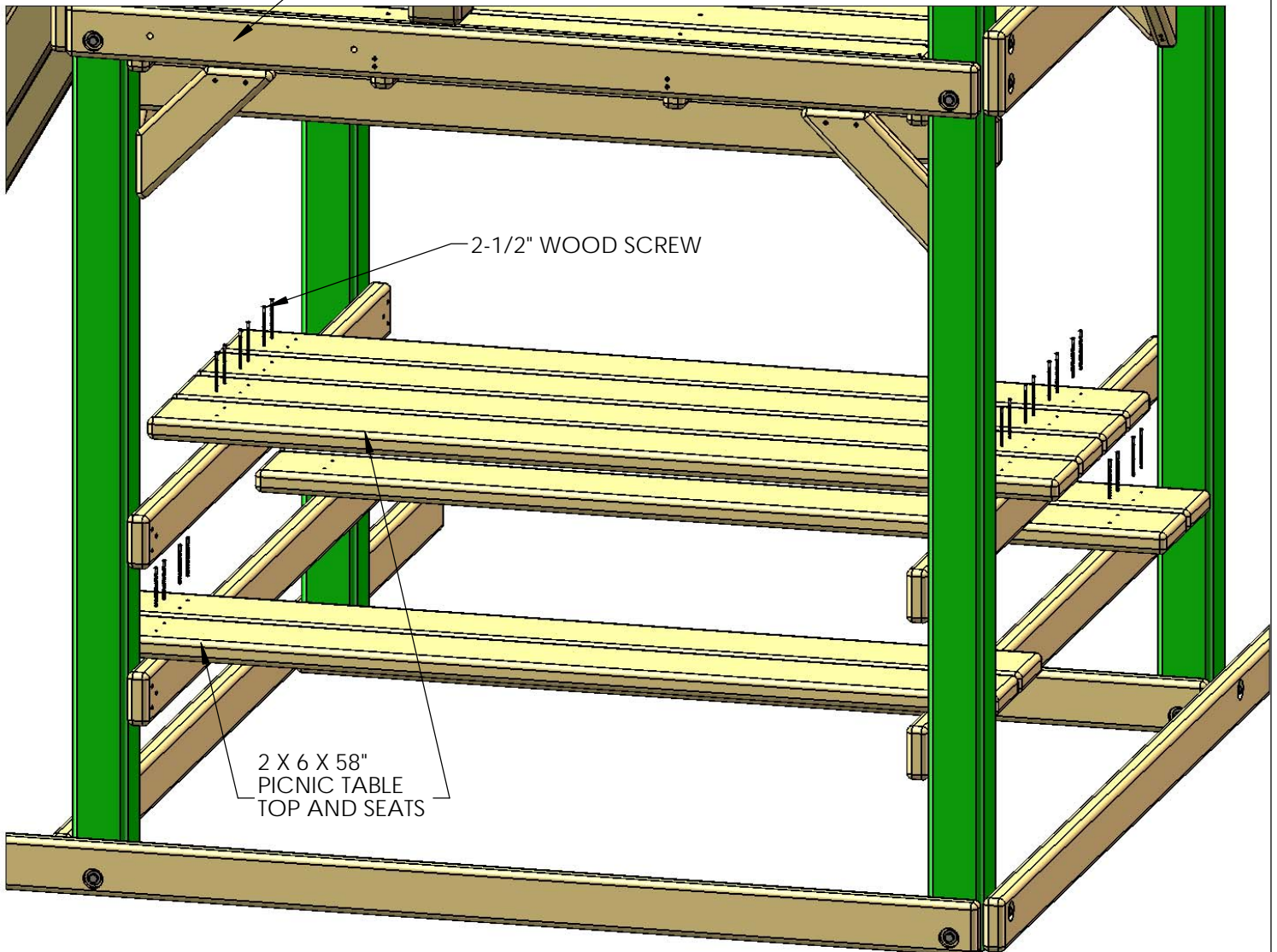

FRONT OF FORT

## STEP 28: PICNIC TABLE STRINGER

- 1: INSTALL THE 2 X 4 X 18" PICNIC TABLE STRINGER UNDERNEATH THE PICNIC TABLE IN THE CENTER.
- 2: FASTEN WITH TWO 2" WOOD SCREWS PER BOARD.

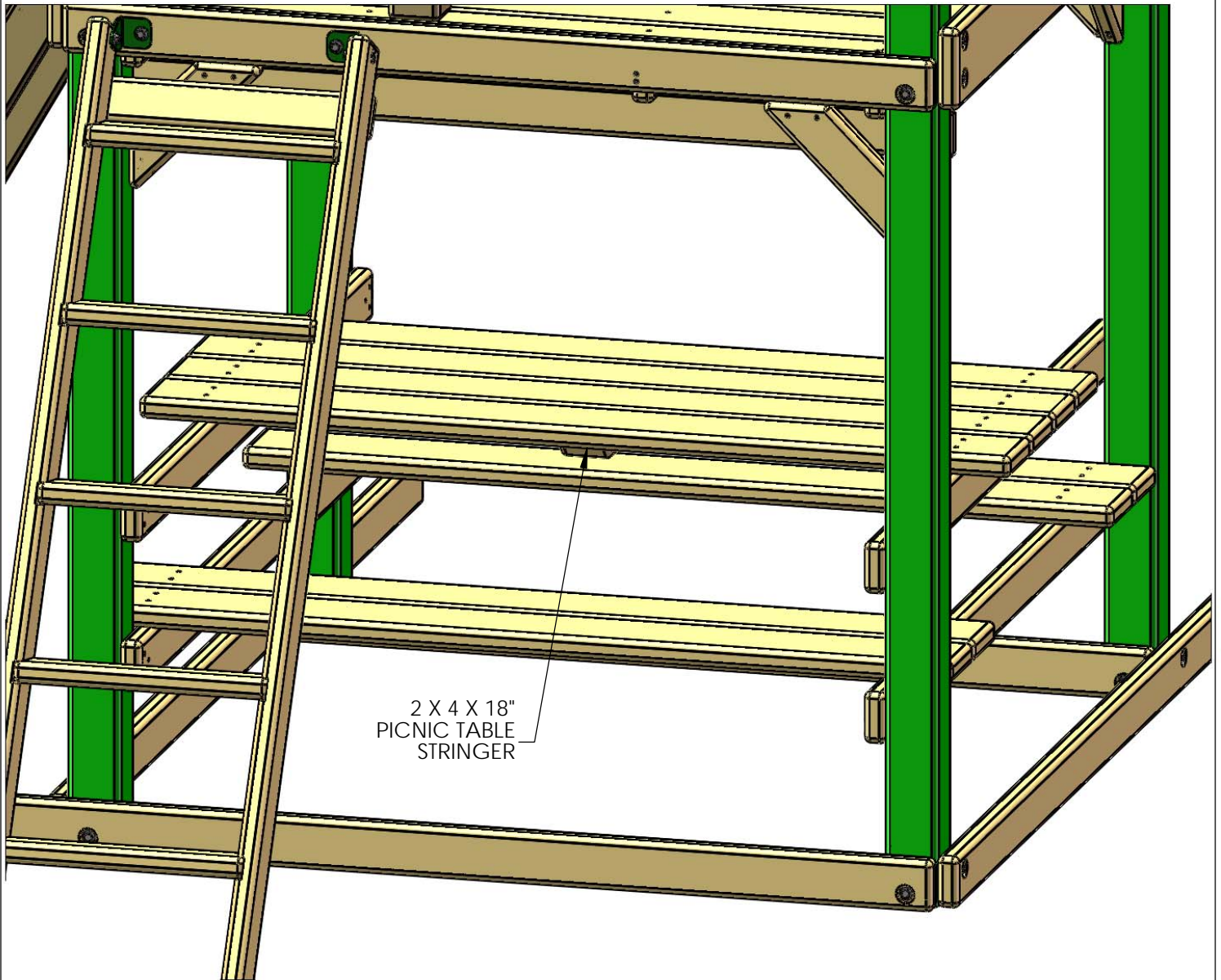

FRONT OF FORT

## STEP 29: PANEL SLATS

1: SPACE THE FIRST 5/4 X 3 X 28" PANEL SLAT FOR EITHER SIDE OF THE FORT 2-5/8" FROM THE CORNER POST AND FASTEN WITH 2" WOOD SCREWS.

2: THE REMAINING PANEL SLATS WILL SECURE APPROX. 2-5/8" FROM THE PREVIOUS SLAT; AGAIN WITH 2" WOOD SCREWS

USE A PANEL SLAT TO DETERMINE SPACING (APPROX. 2-5/8").

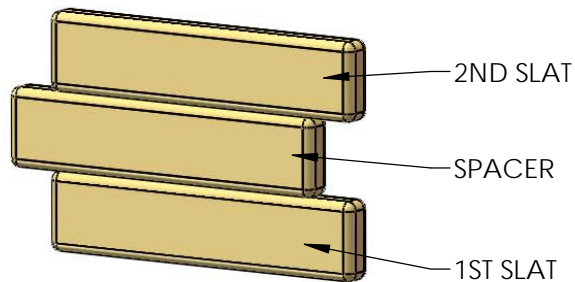

NINE SLATS SWING BEAM SIDE  
FOUR SLATS ROCK WALL SIDE

ALL SLAT SPACING IS APPROX. 2-5/8"

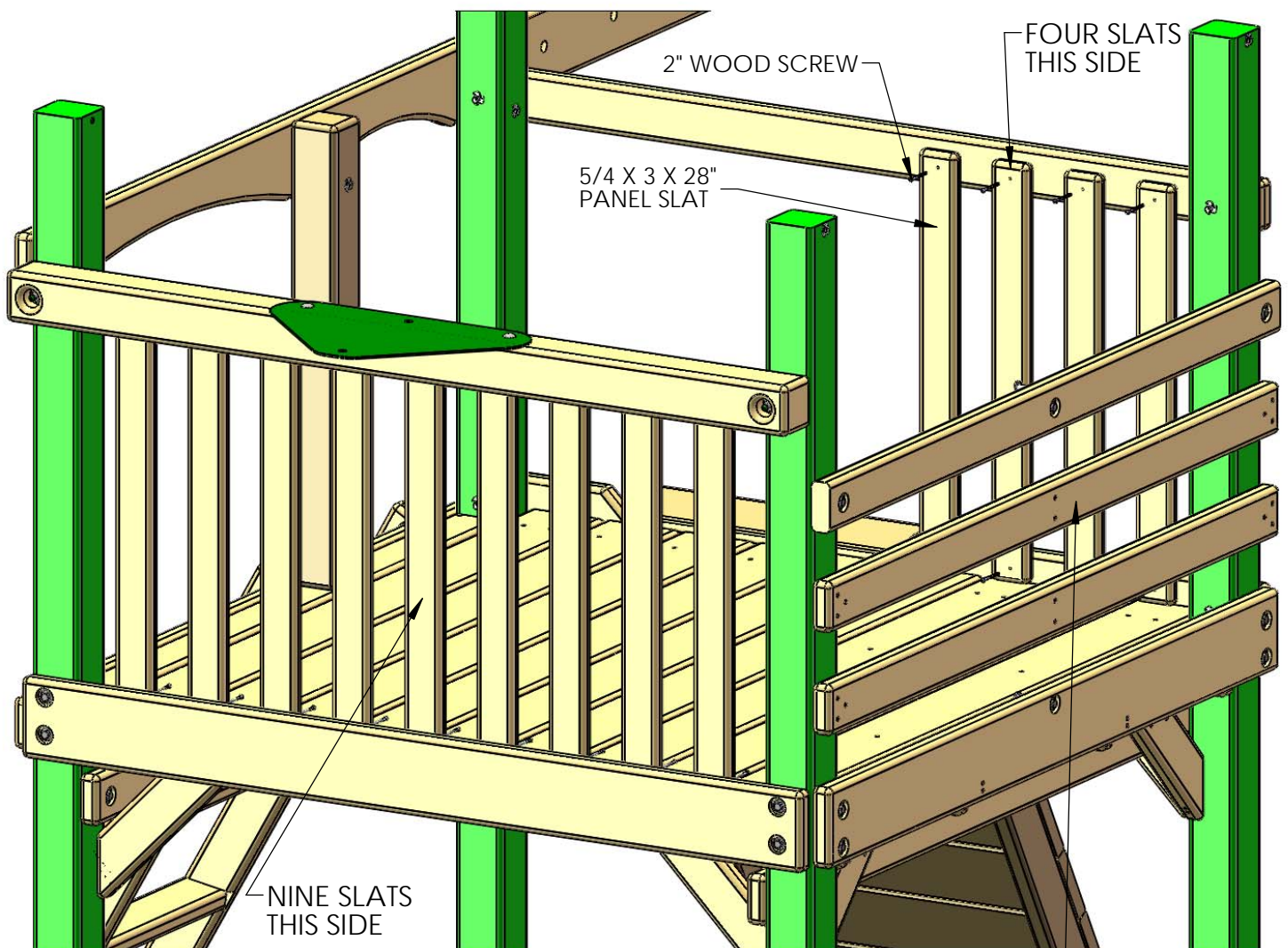

REAR CENTER POST  
REMOVED FROM VIEW  
FOR CLARITY



## STEP 30: IRON DUCTILE SWING HANGERS

- 1: LINE UP THE HOLES OF THE IRON DUCTILE SWING HANGERS WITH THE HOLES IN THE 4 X 6 X 120" SWING BEAM.
- 2: FASTEN THE SWING HANGERS TO THE SWING BEAM USING 7" CARRIAGE BOLTS WITH TORQUE WASHERS, AND 3/8" WASHERS WITH 3/8" LOCK NUTS.
- 3: PLACE BOLT CAPS OVER EXPOSED THREADS ON THE ENDS OF THE CARRIAGE BOLTS.

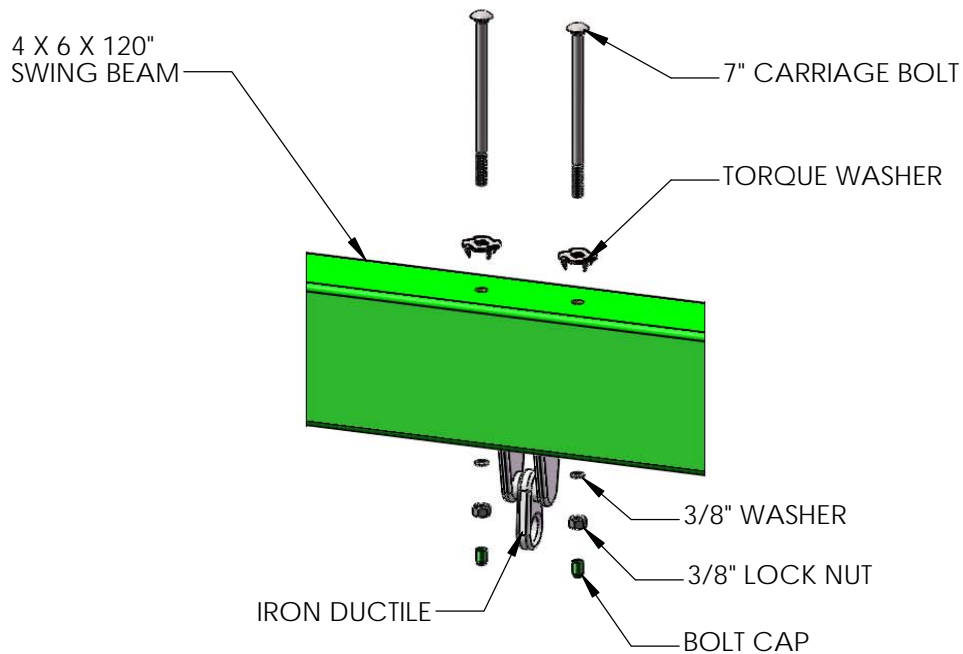
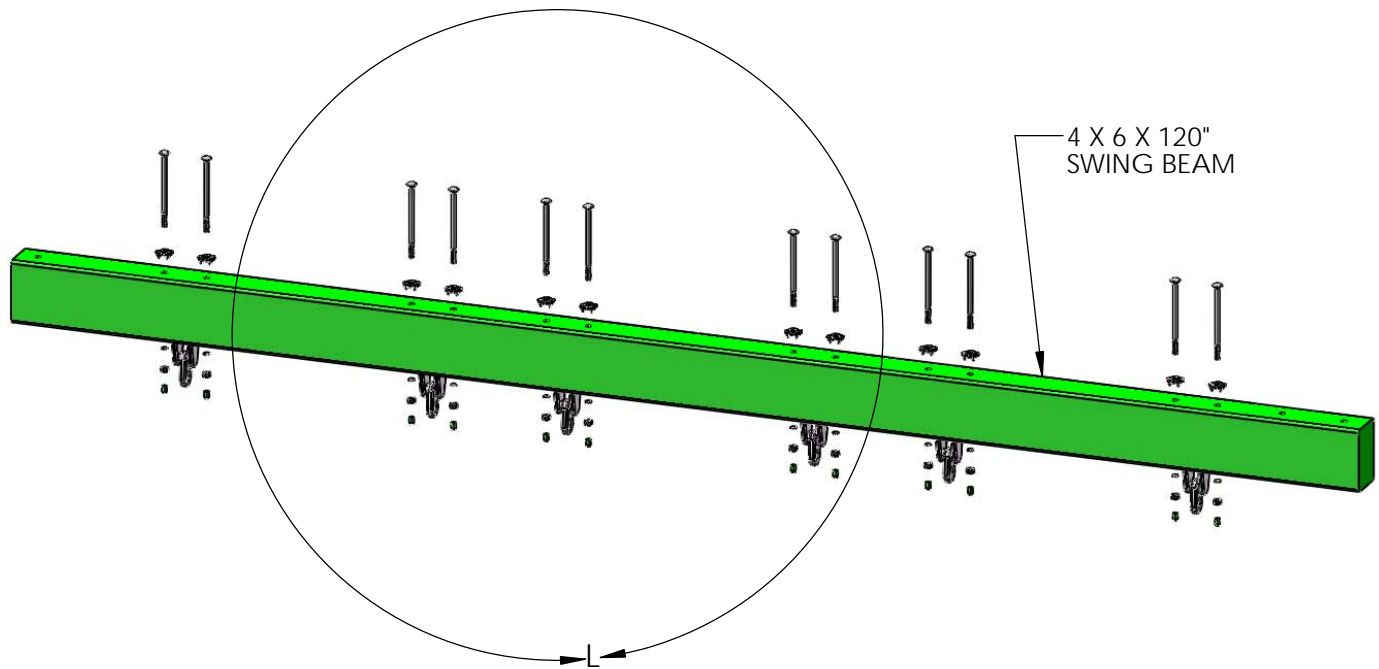

# STEP 31: ATTACH SWING LEGS TO BRACKET

- 1: PLACE THE 4 X 4 X 108" SWING LEGS FLUSH TO THE TOP OF THE SWING LEG BRACKET.
- 2: FASTEN THE SWING LEGS TO THE SWING LEG BRACKET WITH 3/8 X 3-1/2" LAG SCREWS AND 3/8" WASHERS.

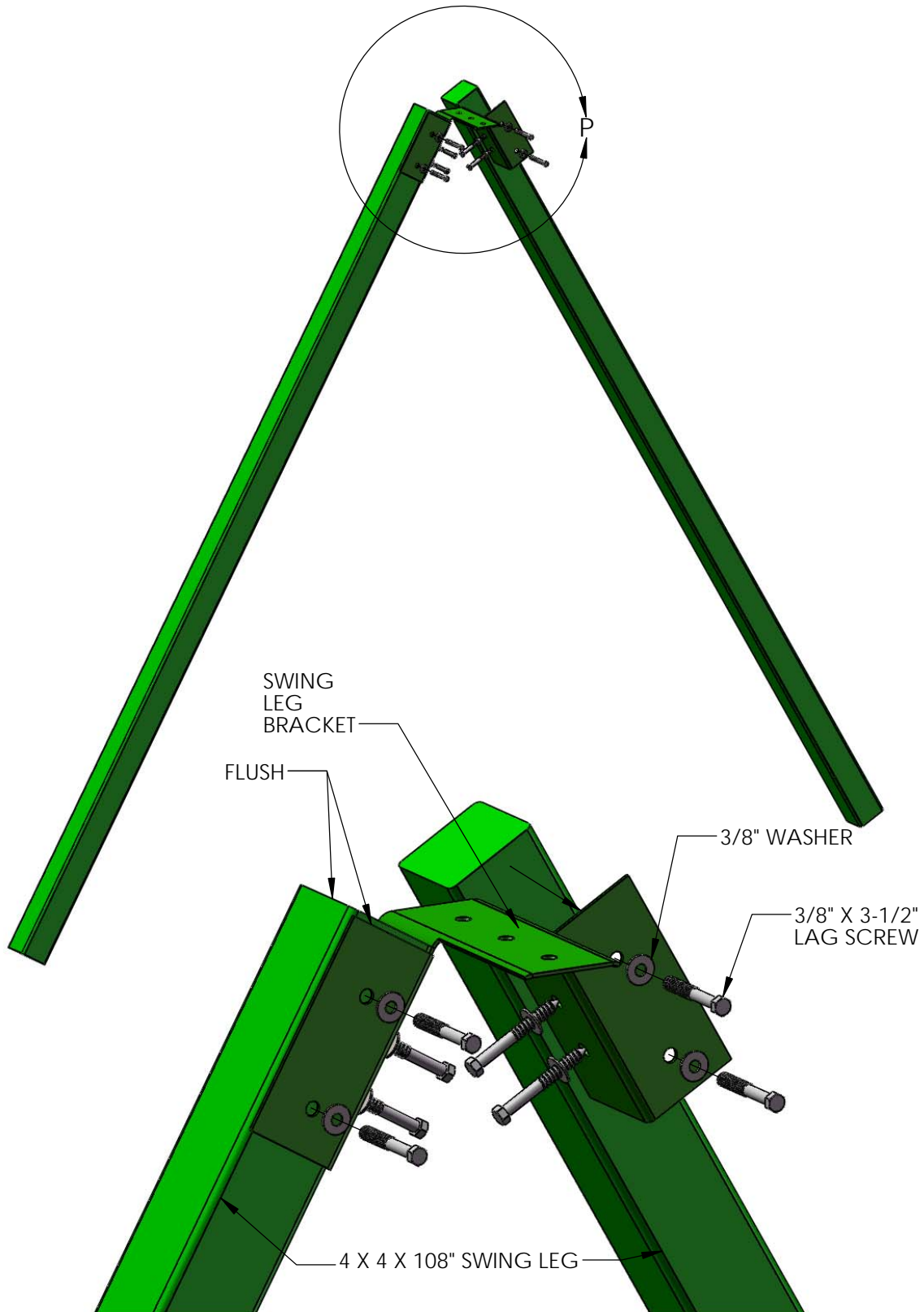

DETAIL P  
SCALE 1 : 5

## STEP 32: REST SWING BEAM ON FORT

\*TWO PEOPLE ARE REQUIRED FOR THIS STEP

1: LAY THE SWING BEAM ACROSS THE FORT AND POSITION THE LEGS UNDERNEATH THE END OF THE BEAM.

2: LINE UP THE PRE-DRILLED HOLES AND REST THE SWING BEAM ON TOP OF THE SWING BEAM SUPPORT PLATE AND SWING LEGS. MAKE SURE THE IRON DUCTILES ARE FACING DOWN.

NOTE:  
THIS END OF BEAM  
HAS TWO HOLES.

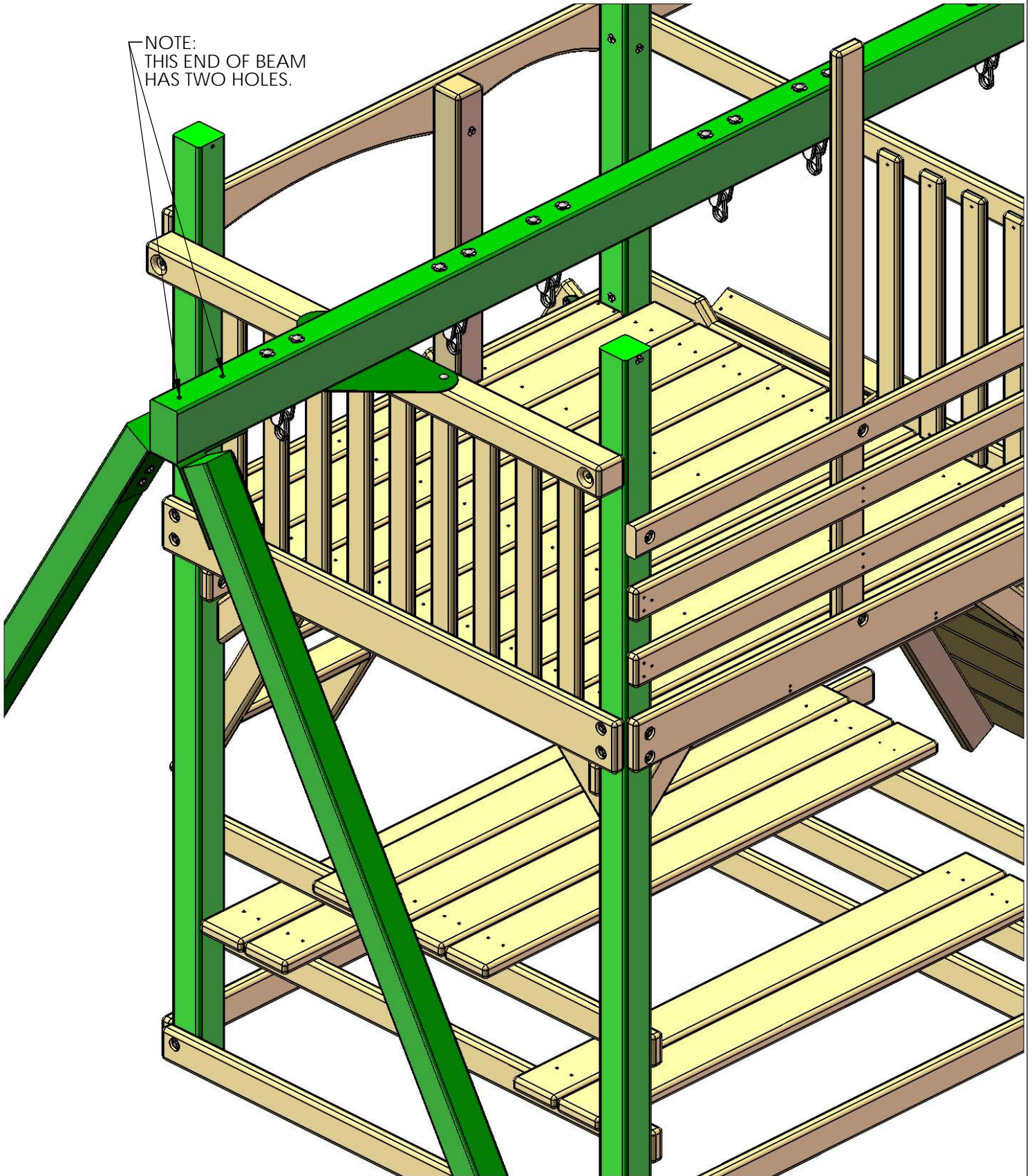

## STEP 33: MOUNT SWING BEAM TO SWING BEAM LEGS

- 1: FASTEN THE SWING BEAM TO THE SWING BEAM BRACKET USING 7" CARRIAGE BOLTS WITH TORQUE WASHERS ON TOP OF THE SWING BEAM, AND 3/8" LOCK NUTS WITH 3/8" WASHERS FROM UNDERNEATH.
- 2: USE A 3/8 X 3-1/2" LAG SCREW WITH 3/8" WASHER FOR THE HOLE IN THE CENTER OF THE SWING BEAM BRACKET.
- 3: PLACE A BOLT CAP OVER ANY EXPOSED THREADS.

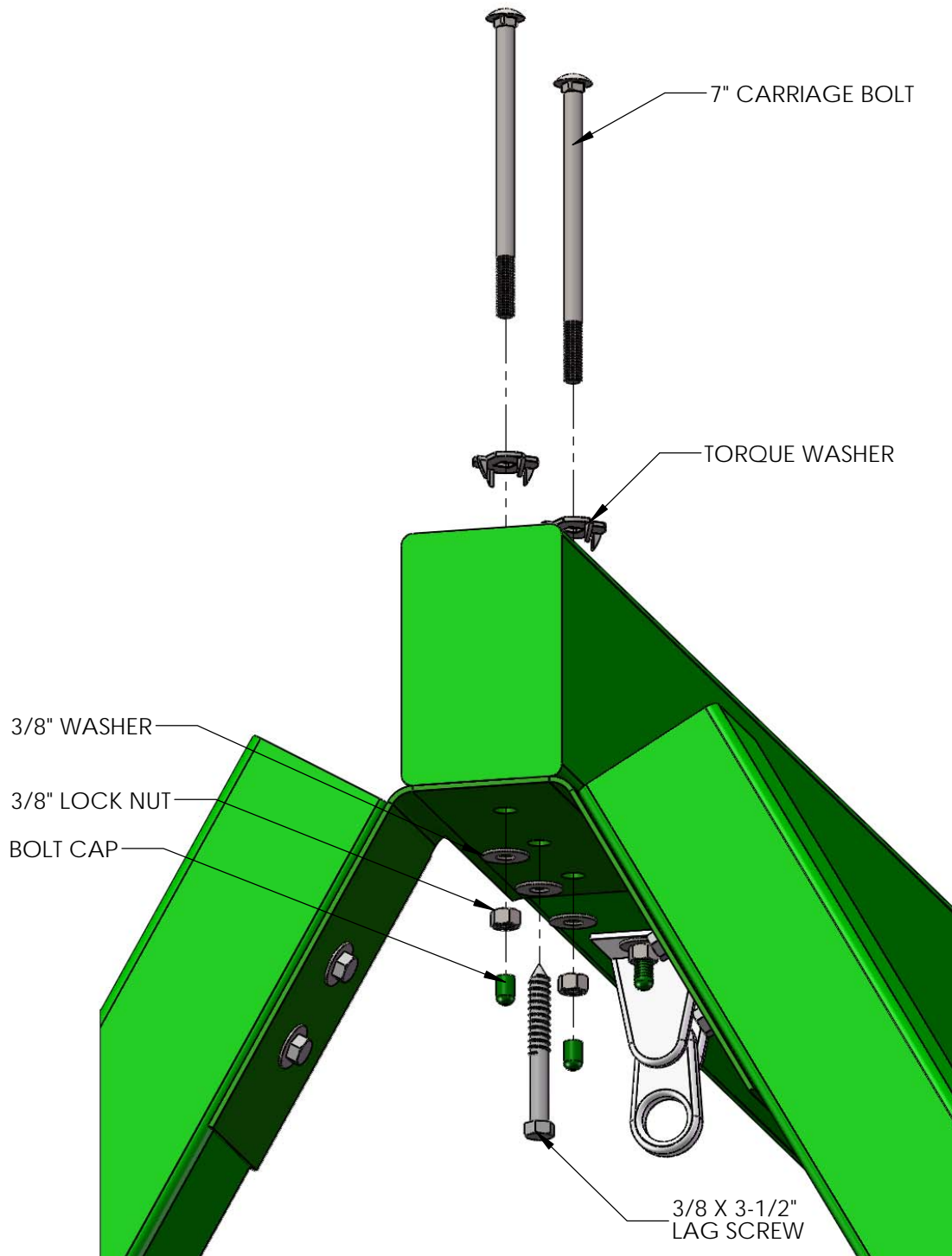

# STEP 34: ATTACHING THE SWING BEAM TO THE FORT

\*AN EXTRA PERSON IS REQUIRED FOR THIS STEP

1: AFTER THE LEGS ARE ATTACHED, HAVE ONE PERSON ON THE GROUND PICK UP THE SWING BEAM BY THE LEGS, AND ANOTHER PERSON PICK UP THE SWING BEAM FROM INSIDE THE FORT AND WALK OUT THE SWING BEAM.

2: LINE UP THE PILOT HOLE ON THE END OF THE SWING BEAM WITH THE MIDDLE HOLE ON THE SWING BEAM PLATE.

3: FASTEN THE SWING BEAM TO THE SWING BEAM PLATE AND SWING BEAM SUPPORT USING A 9" CARRIAGE BOLT WITH A TORQUE WASHER ON TOP AND A 3/8" LOCK NUT AND WASHER ON THE BOTTOM. PLACE A GREEN BOLT CAP OVER EXPOSED THREADS AFTER SECURING.

4: FASTEN THE SWING BEAM TO THE SWING BEAM PLATE FROM UNDERNEATH WITH A 3/8 X 3-1/2" LAG SCREW AND A 3/8" WASHER.

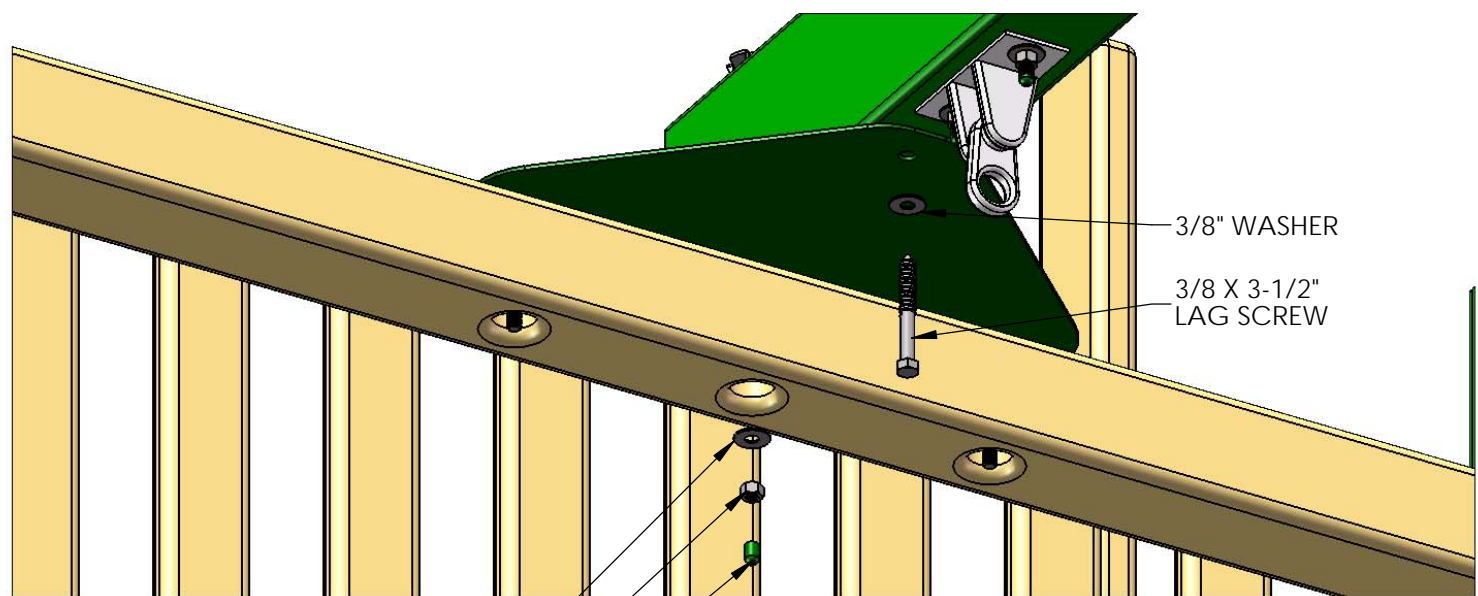
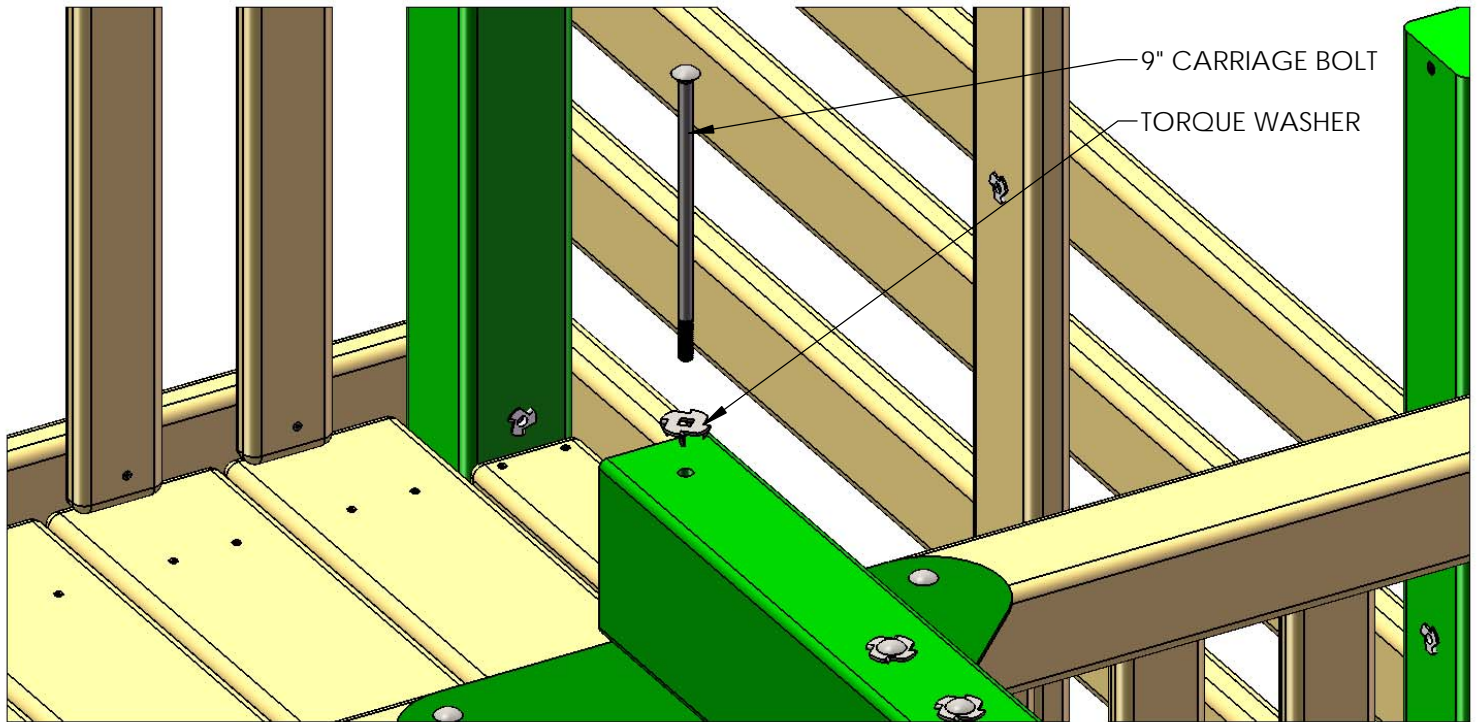

3/8" WASHER  
3/8" LOCK NUT  
BOLT CAP

## STEP 35: LEVEL SWING BEAM

1: PLACE A LEVEL ON TOP OF THE SWING BEAM AND ADJUST THE BEAM LEGS IN OR OUT AS NEEDED TO MAKE THE SWING BEAM LEVEL.



IMPORTANT NOTE:  
THE LEGS ARE  
DESIGNED TO  
ACCOMMODATE  
SWING BEAMS  
ON UNEVEN  
GROUND (DOWN  
SLOPE). THEY ARE  
LONGER THAN  
REQUIRED. IF  
YOUR GROUND IS  
RELATIVELY LEVEL,  
YOU MAY NEED  
TO EITHER A) DIG  
IN BOTH LEGS  
WHERE THEY MEET  
THE GROUND, OR  
B) BEND THE LEGS  
OUT SLIGHTLY TO  
MATCH YOUR  
GRADE

## STEP 36: SWING LEG CROSS-MEMBER

- 1: POSITION THE 4 X 4 X 58" SWING LEG CROSS-MEMBER AGAINST THE SWING BEAM LEGS.
- 2: LEVEL CROSS-MEMBER AND MARK THE LOCATION OF THE SECURING HOLES INSIDE THE CROSS-MEMBER HOLES.
- 3: USE 3/8 X 5" LAG SCREWS WITH 3/8" WASHERS TO SECURE THE CROSS-MEMBER TO THE SWING BEAM LEGS.

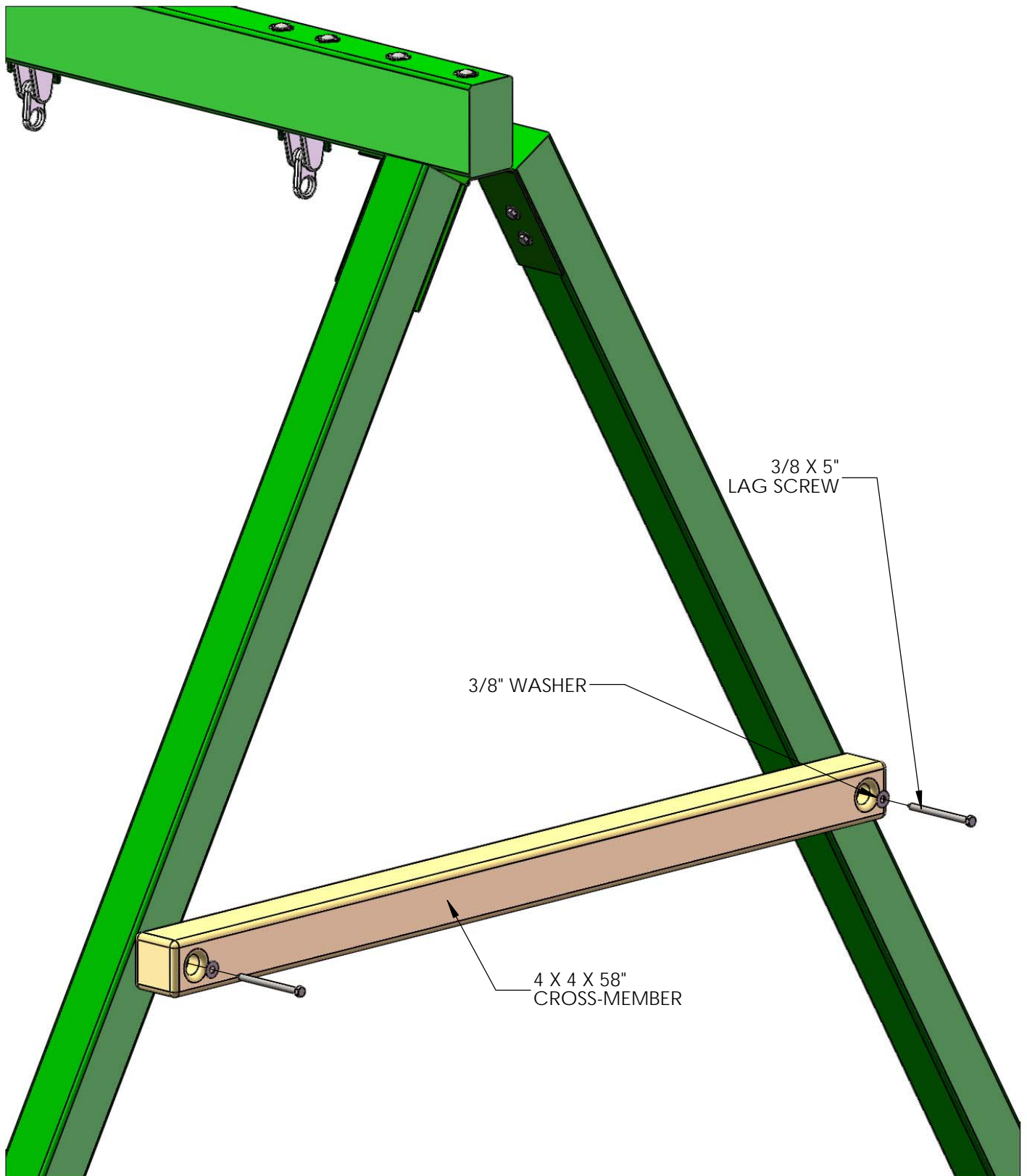

## STEP 37: T-NUTS

- 1: THIS STEP IS CRITICAL TO BUILDING THE UPPER LEVEL PROPERLY. IF ANY MISTAKES ARE MADE HERE, YOU WILL NEED TO DIS-ASSEMBLE AND THEN RE-ASSEMBLE TO MAKE YOUR CORRECTIONS.
- 2: MAKE SURE HOLES ARE FREE OF ANY OBSTRUCTIONS. USE A BOLT TO CLEAN OUT ANY DEBRIS.
- 3: USE THE DIAGRAM BELOW TO CORRECTLY IDENTIFY AND ORIENT THE CORNER POSTS.
- 4: USE A HAMMER TO SEAT THE T-NUTS AFTER INSERTING THEM INTO THE HOLES SHOWN IN THE DIAGRAM BELOW.
- 5: THE BARREL OF THE T-NUT SHOULD GO IN THE HOLE FIRST. HAMMER THE T-NUT UNTIL IT IS FLUSH/ALMOST FLUSH WITH THE OUTSIDE SURFACE OF THE CORNER POSTS.

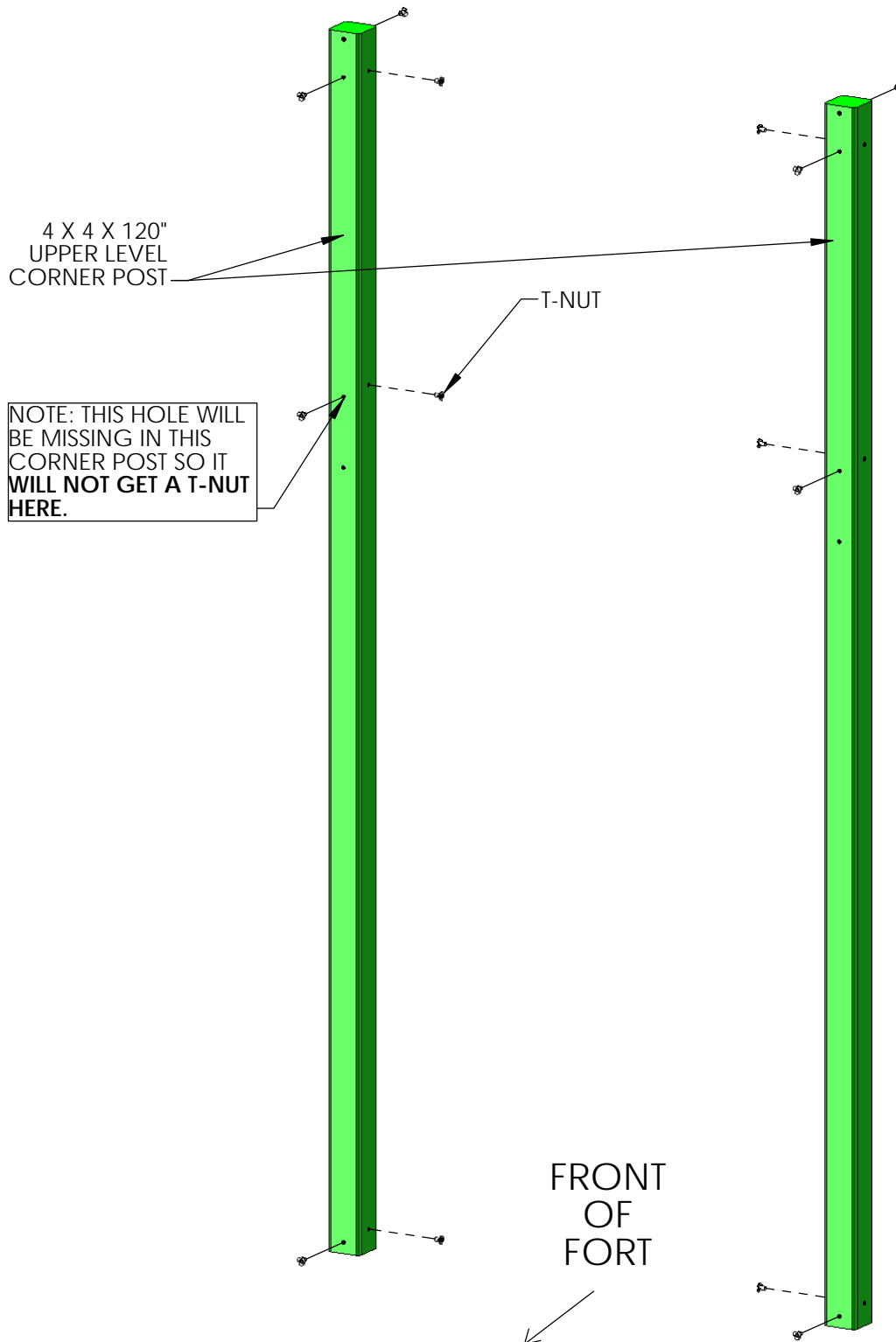



## STEP 38: LAG POSTS

- 1: TWO 4 X 4 X 41-5/16" UPPER LEVEL LAG POSTS WILL BE USED TO EXTEND THE CORNER POSTS TO ACCEPT THE UPPER LEVEL ROOF.
- 2: THE LAG POSTS WILL REST ON TOP OF THE UPPER LEVEL DECK SUPPORT ON THE LOWER LEVEL.
- 3: USE THE LARGER 3/8 X 5" LAG SCREWS WITH 3/8" WASHERS TO SECURE THE LAG POSTS TO THE CORNER POSTS. A HAMMER MAY BE NEEDED TO START THE LAG SCREWS BEFORE DRIVING THEM INTO THE POSTS WITH A RATCHET WRENCH.
- 4: USE THE DIAGRAM BELOW TO INSTALL T-NUTS INTO THE LAG POSTS.

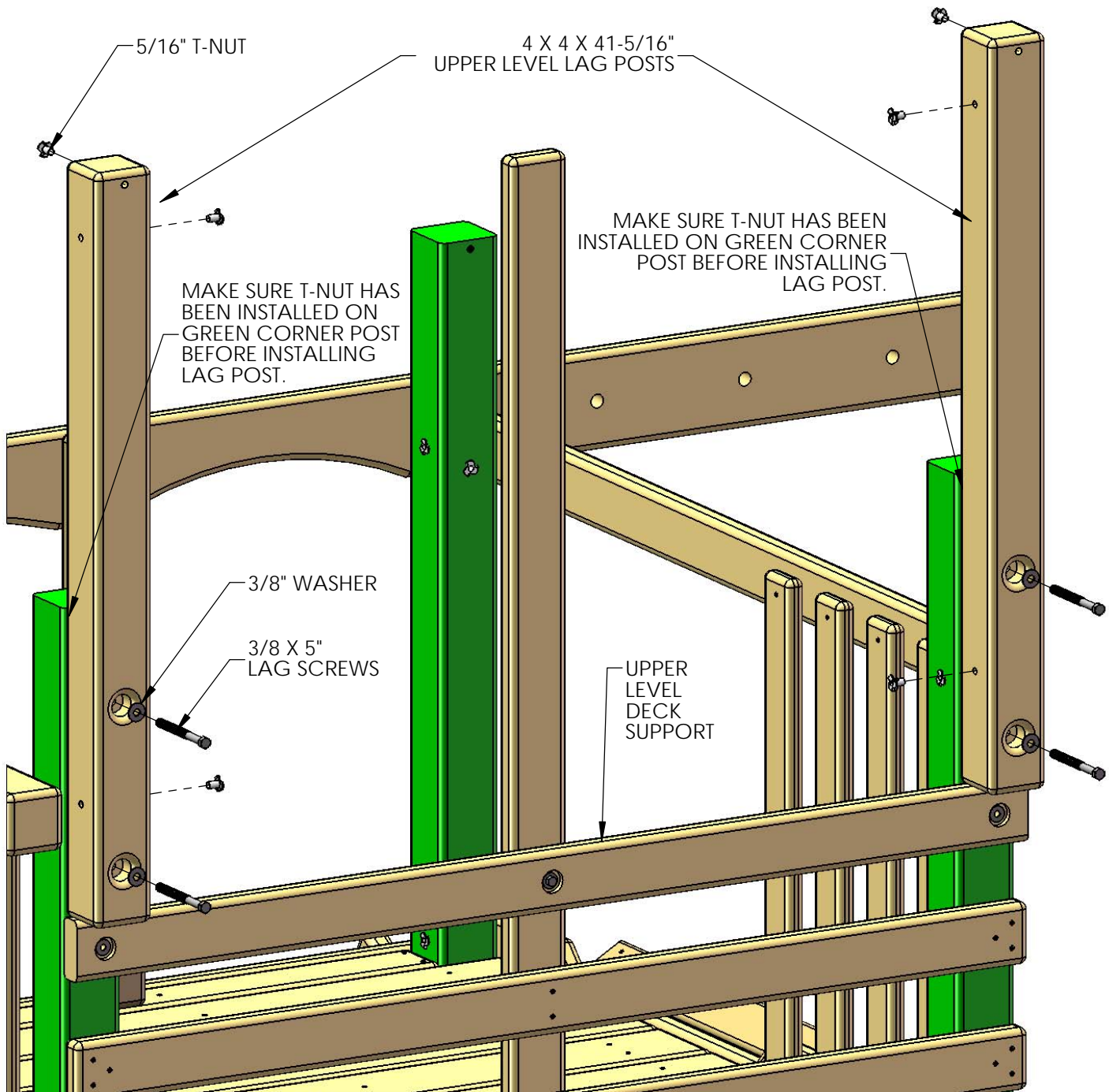

## STEP 39: UPPER LEVEL CORNER POSTS

1: THE 4 X 4 X 120" REAR CORNER POSTS WILL ATTACH TO THE ENDS OF THE SANDBOX BOARDS WITH 5/16 X 4-1/2" HEX BOLTS AND 5/16" WASHERS.

2: THE 2 X 4 X 58" SANDBOX BOARD SECURES AT THE BASE OF THE REAR CORNER POSTS, HOLES OFFSET DOWN, WITH 5/16 X 4-1/2" HEX BOLTS AND 5/16" WASHERS.

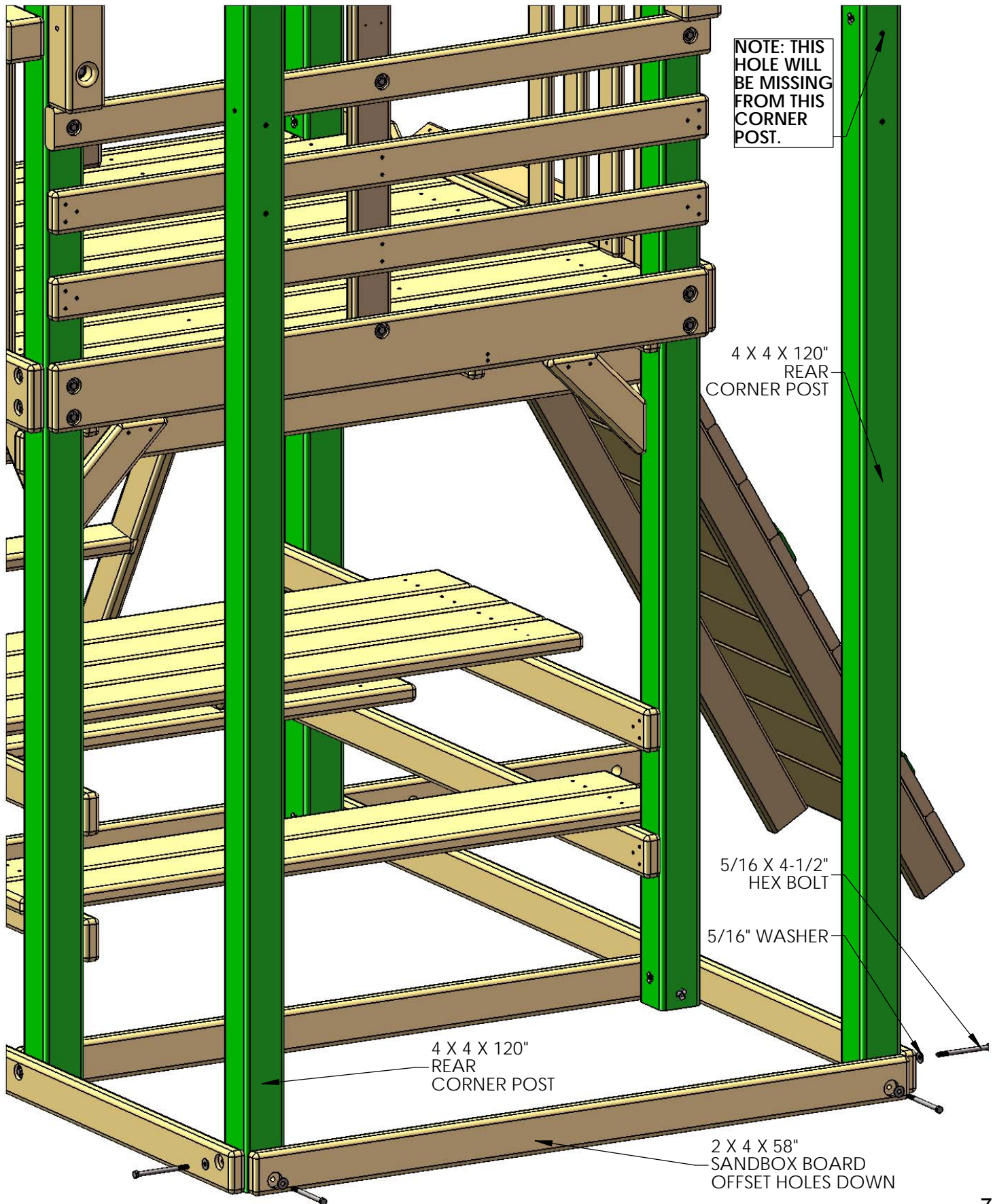

## STEP 40: UPPER LEVEL DECK SUPPORT

- 1: THE 4 X 4 X 58" UPPER LEVEL DECK SUPPORT WILL MOUNT TO THE CORNER POSTS USING 6-1/2" CARRIAGE BOLTS WITH TORQUE WASHERS FROM THE OUTSIDE.
- 2: USE 3/8" LOCK NUTS AND 3/8" WASHERS IN THE COUNTER-SUNK HOLES OF THE UPPER LEVEL DECK SUPPORT.
- 3: COVER ANY EXPOSED THREADS WITH BOLT CAPS.

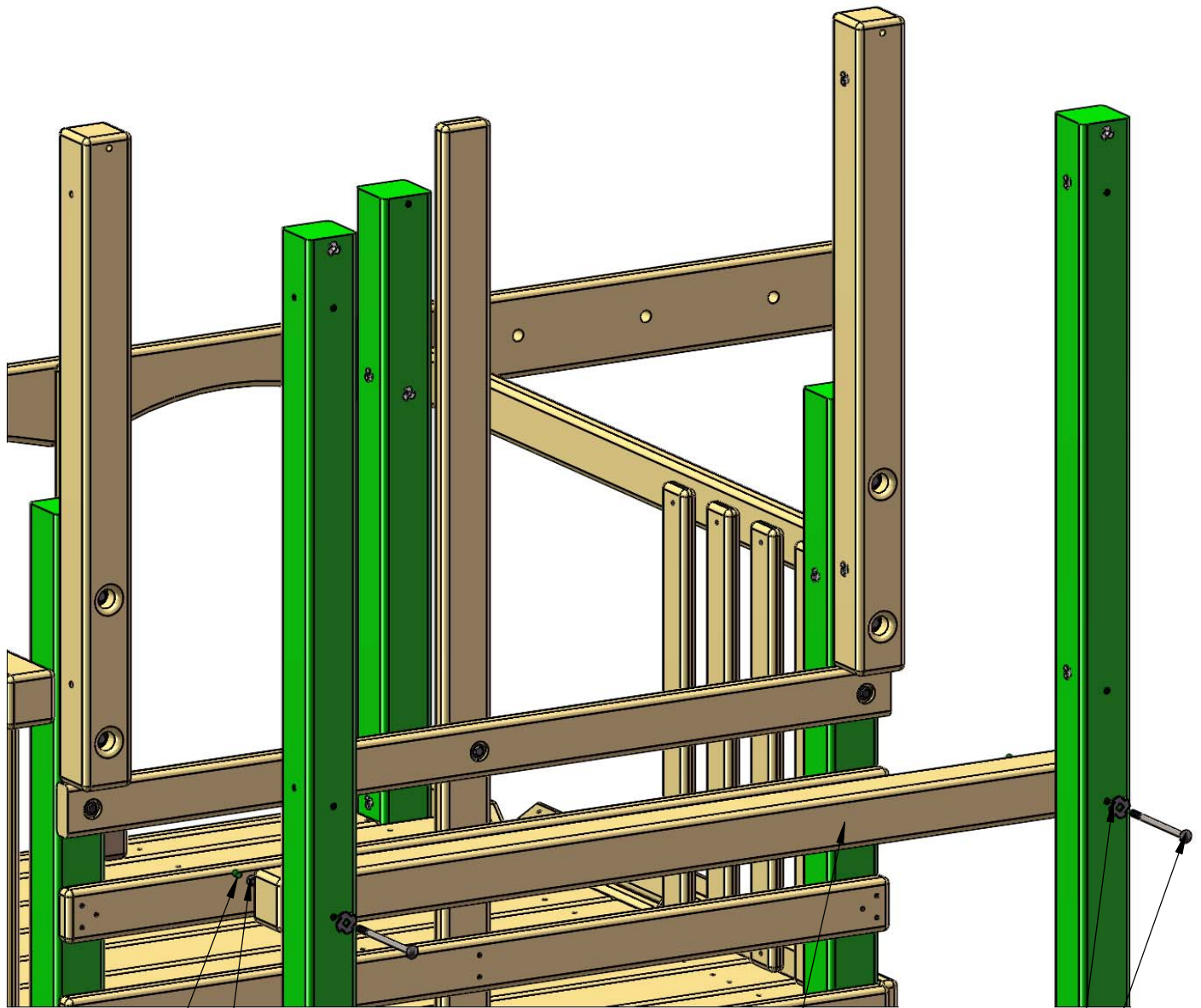

BOLT CAP  
3/8" WASHER  
3/8" LOCK NUT

4 X 4 X 58"  
UPPER LEVEL  
DECK SUPPORT

TORQUE WASHER  
6-1/2" CARRIAGE  
BOLT

## STEP 41: UPPER LEVEL DECK SUPPORT

1: THE 2 X 4 X 30-3/4" UPPER LEVEL DECK SUPPORT WILL REST ON THE FRONT AND REAR DECK SUPPORTS, FLUSH WITH THE CORNER POSTS.

2: USE 5/16 X 3-1/2" LAG SCREWS AND 5/16" WASHERS TO SECURE THE DECK SUPPORTS TO THE CORNER POSTS.

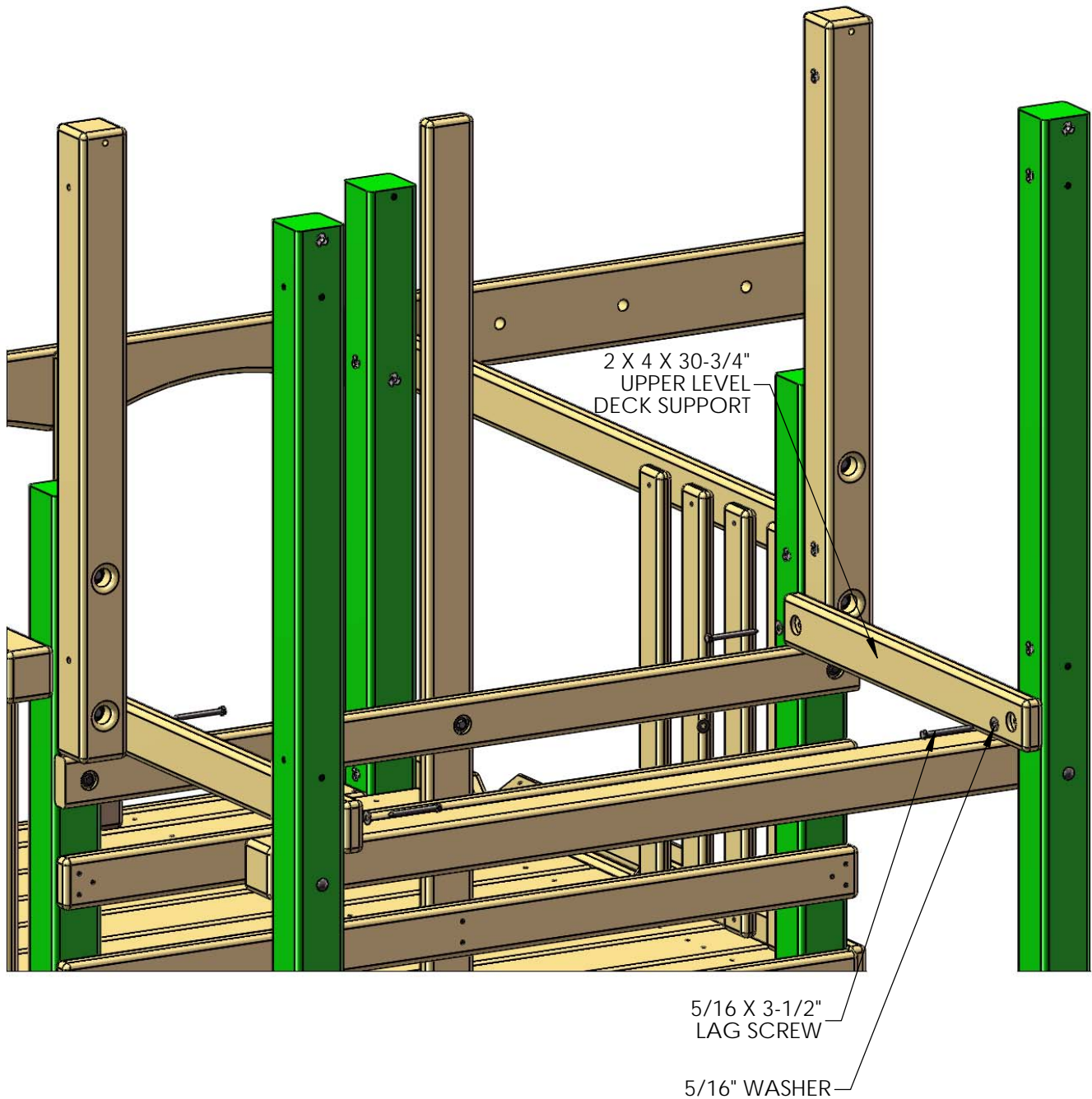

## STEP 42: SANDBOX BOARDS

- 1: TWO 2 X 4 X 58" (TWO HOLES, ON CENTER) SANDBOX BOARDS WILL SECURE ON TO THE FRONT AND REAR CORNER POSTS OF THE SANDBOX.
- 2: USE TWO 5/16 X 3-1/2" LAG SCREWS WITH 5/16" WASHERS PER BOARD.
- 3: TWO 2 X 4 X 34" (TWO HOLES, OFFSET) SANDBOX BOARDS WILL SECURE ON TO THE SIDES OF THE SANDBOX WITH OFFSET HOLES DOWN.
- 4: USE TWO 5/16 X 3-1/2" LAG SCREWS WITH 5/16" WASHERS PER BOARD.

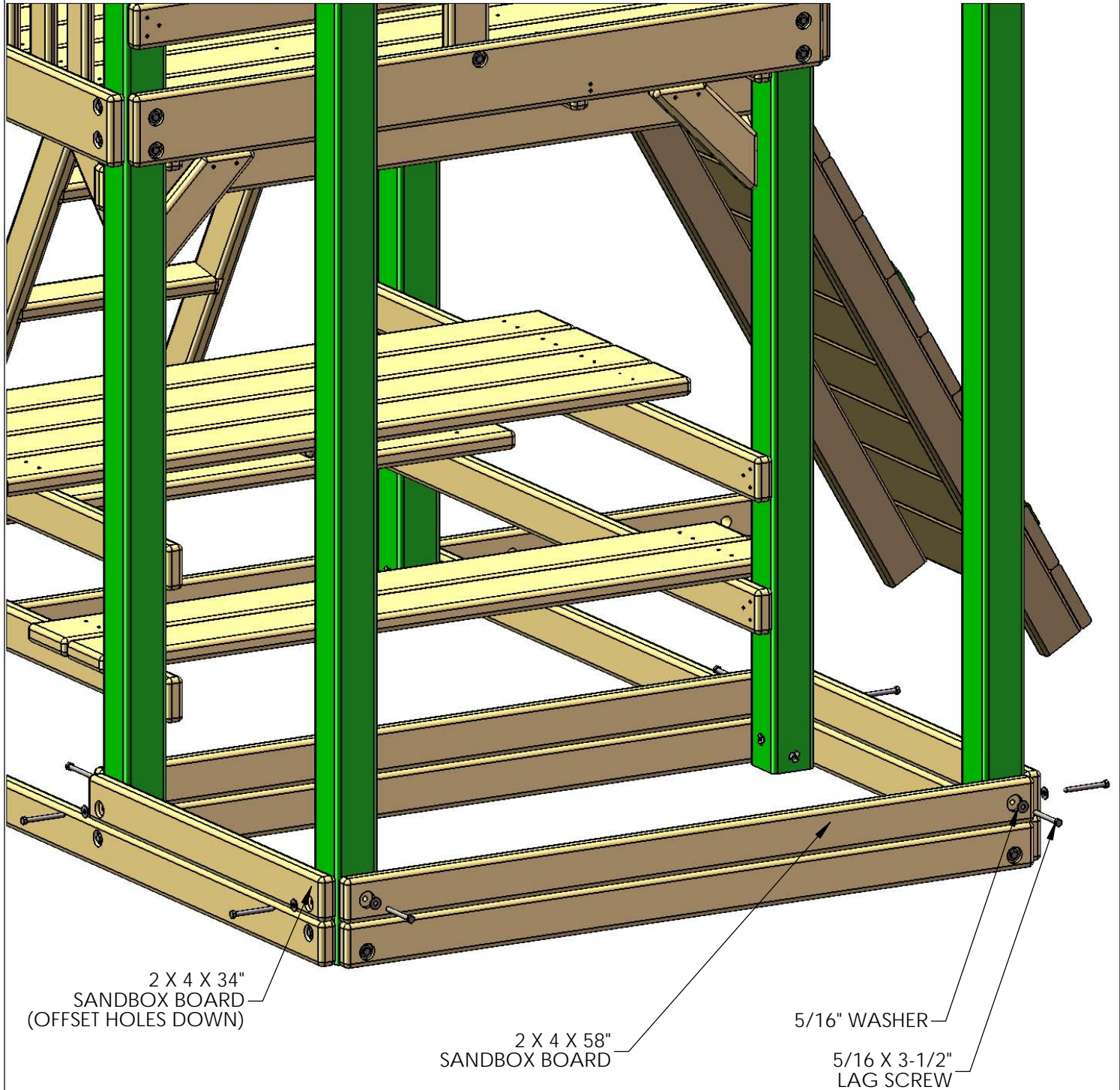

## STEP 43: UPPER PANEL BOARDS OF UPPER DECK

- 1: TWO 2 X 4 X 30-3/4" UPPER LEVEL SIDE TOP PANEL BOARDS WILL MOUNT ON EITHER SIDE OF THE CORNER POSTS WITH THE OFFSET HOLES UP.
- 2: USE TWO 5/16 X 4-1/2" HEX BOLTS WITH TWO 5/16" WASHERS PER BOARD TO ATTACH EACH UPPER LEVEL SIDE TOP PANEL BOARD TO THE POSTS.
- 3: THE 2 X 4 X 58" UPPER LEVEL DECK SUPPORT WILL MOUNT ON THE BACK OF THE CORNER POSTS.
- 4: USE TWO 5/16 X 4-1/2" HEX BOLTS WITH TWO 5/16" WASHERS TO ATTACH THE UPPER LEVEL DECK SUPPORT TO THE CORNER POSTS.

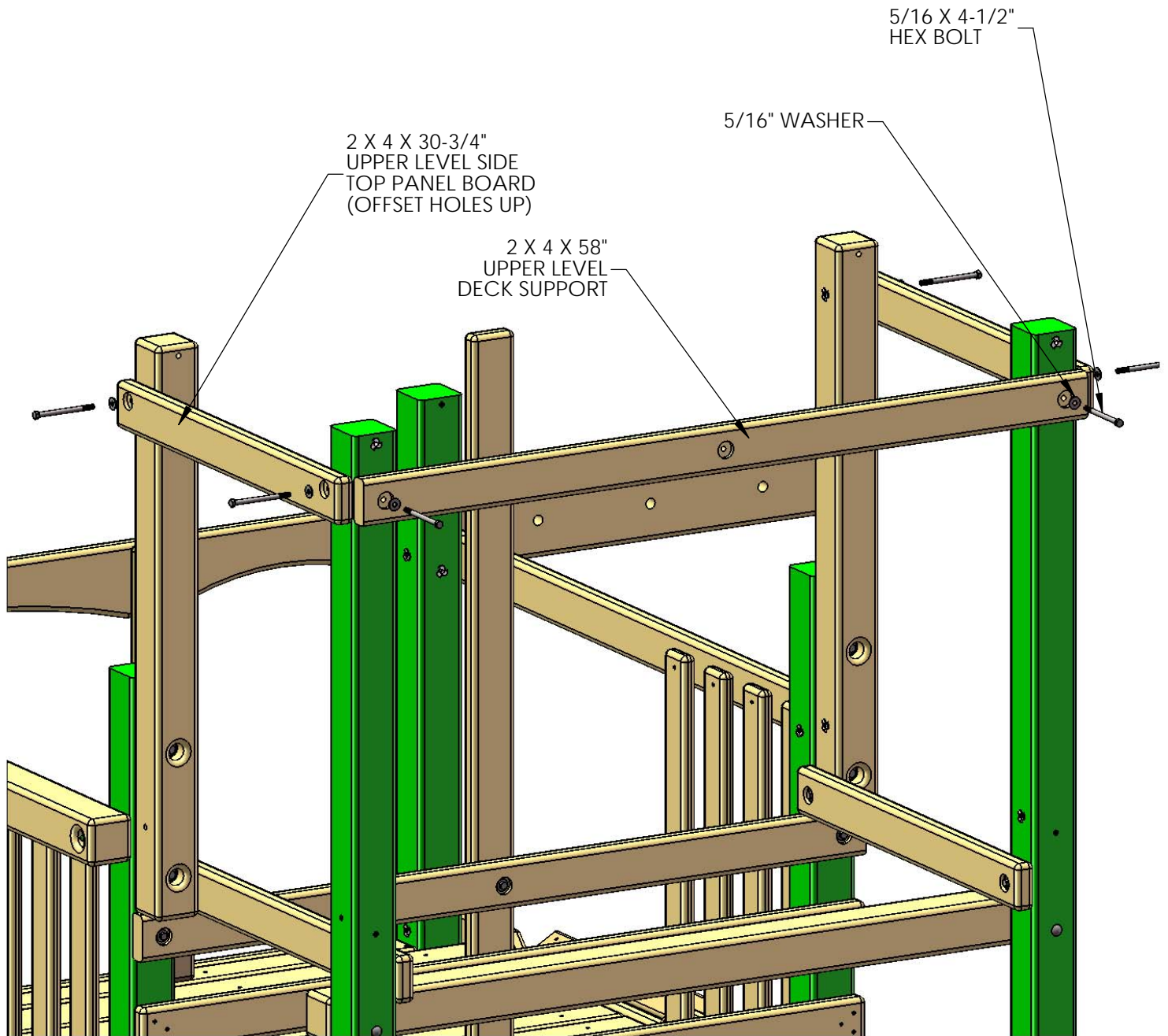

## STEP 44: UPPER LEVEL REAR CENTER POST

- 1: FIND THE 4 X 4 X 44-1/4" UPPER LEVEL REAR CENTER POST, AND INSTALL A T-NUT INTO THE 3/8" HOLE AT THE TOP OF THE POST. NOTE THE ORIENTATION OF THE COUNTER-SUNK HOLE AND THE T-NUT.
- 2: PLACE THE REAR CENTER POST AT THE BACK OF THE FORT, ALLOWING THE HOLE AT THE TOP OF THE POST TO LINE UP WITH THE HOLE IN THE CENTER OF THE TOP PANEL BOARD. ATTACH THE REAR CENTER POST TO THE TOP PANEL BOARD USING A 5/16 X 4-1/2" HEX BOLT WITH A 5/16" WASHER.
- 3: MAKE SURE THAT THE UPPER LEVEL REAR CENTER POST IS SQUARE TO THE 4 X 4 UPPER LEVEL DECK SUPPORT, AND ATTACH IT THROUGH THE COUNTER-SUNK HOLE USING A 3/8 X 5" LAG SCREW WITH A 3/8" WASHER.

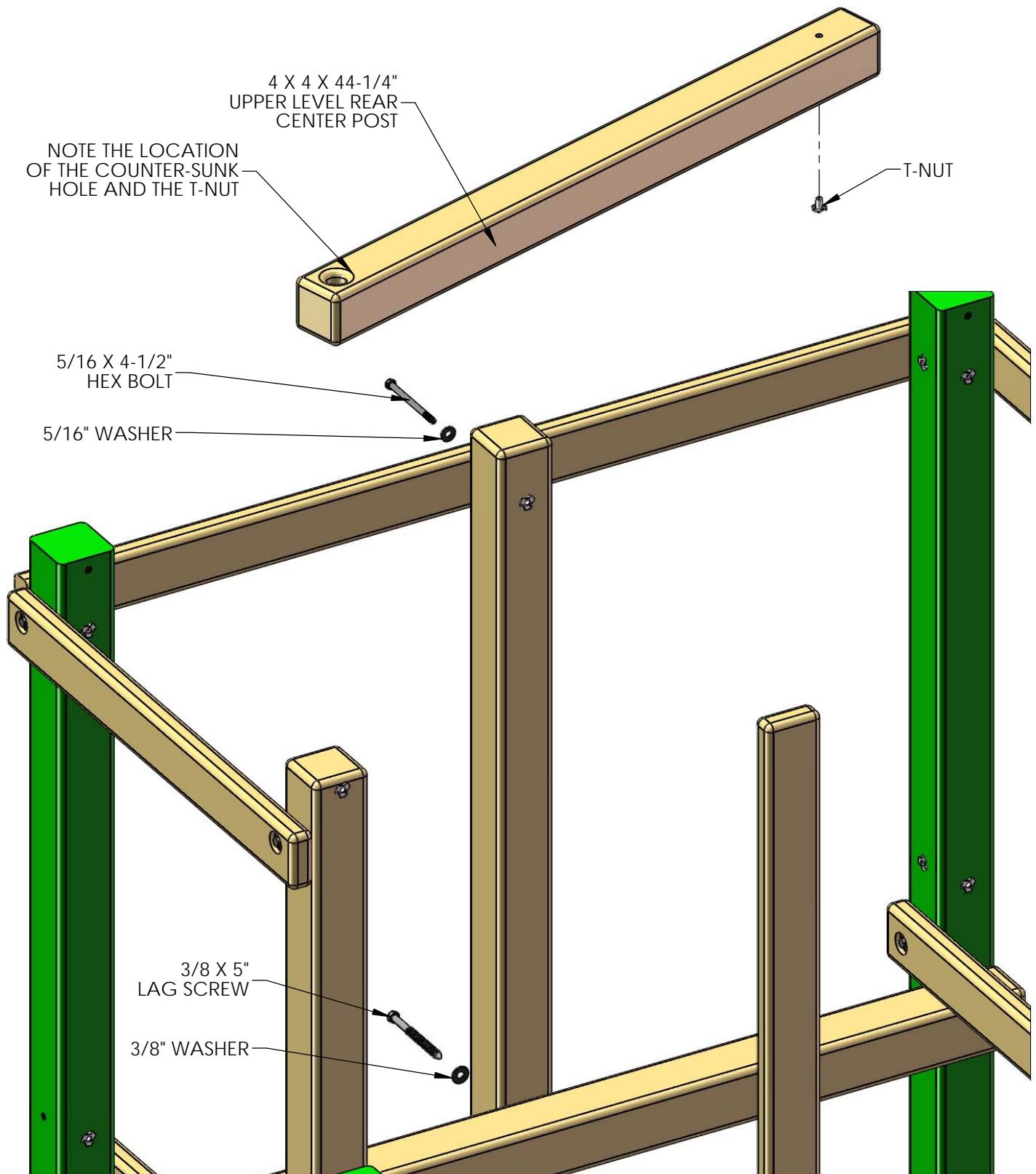

## STEP 45: UPPER LEVEL FRONT CENTER POST

1: PLACE THE UPPER LEVEL FRONT CENTER POST AT THE FRONT OF THE UPPER LEVEL FLUSH TO THE SIDES OF THE LOWER LEVEL REAR CENTER POST, ALLOWING THE BASE OF THE POST TO REST ON THE SAME BOARD AS THE LAG POSTS.

2: ONCE THE UPPER LEVEL FRONT CENTER POST IS SET INTO PLACE, USE TWO 2-1/2" WOOD SCREWS IN THREE LOCATIONS TO SECURE IT TO THE LOWER LEVEL REAR CENTER POST.

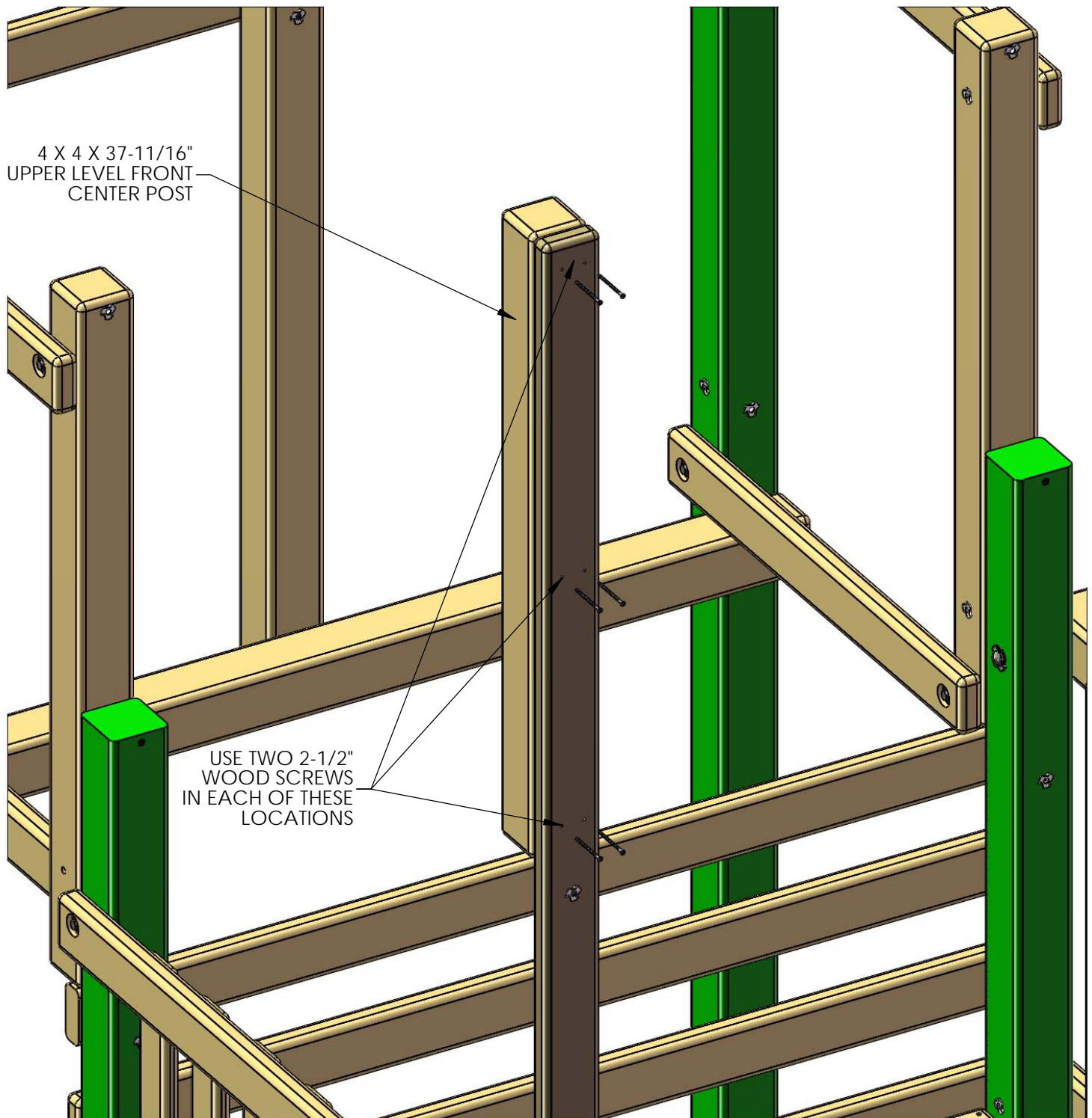



## STEP 46: UPPER LEVEL CENTER DECK SUPPORTS

1: TWO 2 X 4 X 30-3/4" UPPER LEVEL CENTER DECK SUPPORTS WILL MOUNT ON EITHER SIDE OF THE CENTER POSTS, FLUSH TO THE ENDS, WITH FOUR 2-1/2" WOOD SCREWS PER BOARD (TWO EACH END).

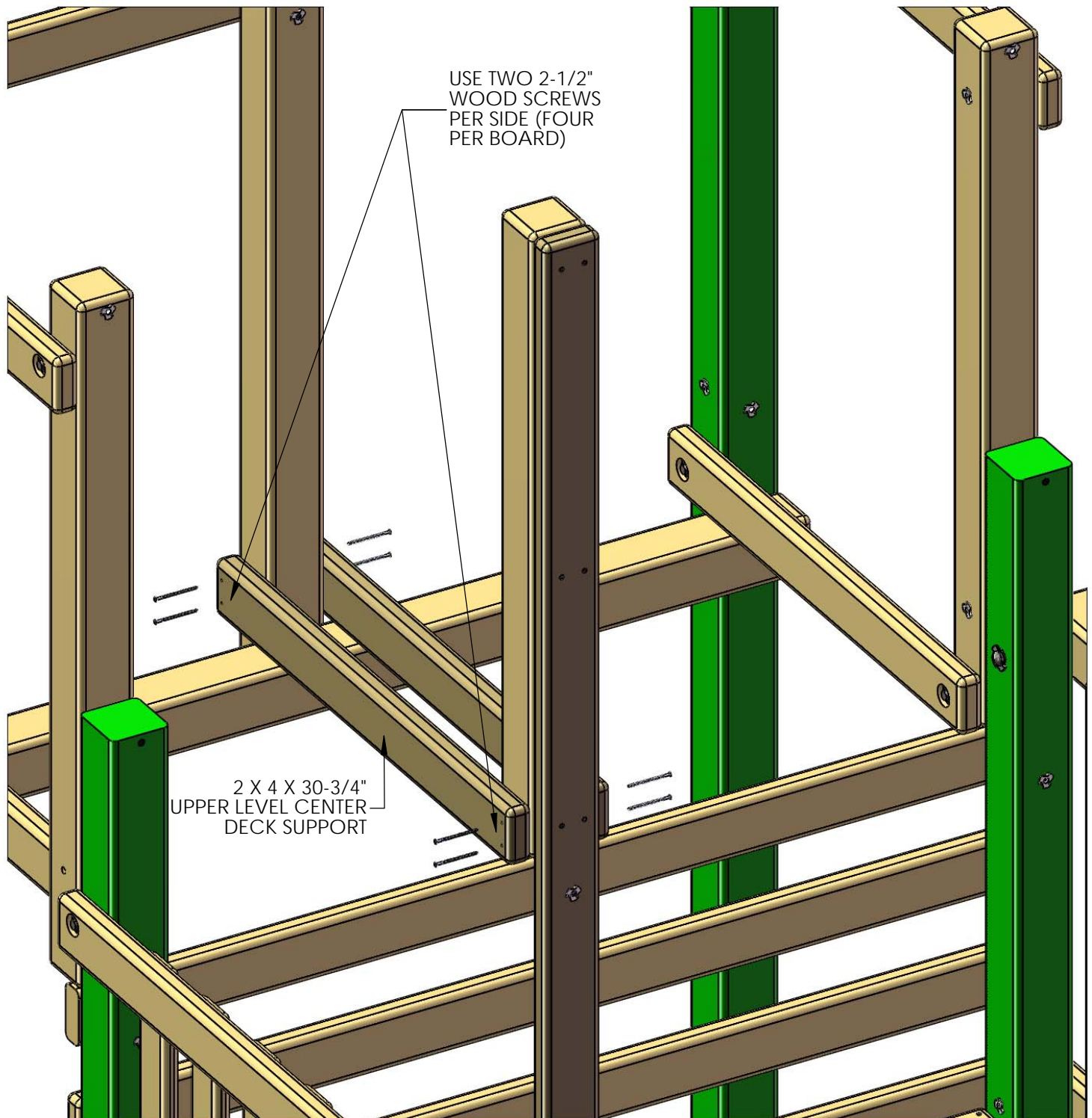

## STEP 47: UPPER LEVEL BOTTOM PANEL BOARDS

- 1: FIND TWO 2 X 6 X 30-3/4" UPPER LEVEL BOTTOM PANEL BOARDS. LINE THE TOP HOLES OF THE UPPER LEVEL BOTTOM PANEL BOARDS WITH THE HOLES IN THE CORNER POSTS AND THE LAG POSTS.
- 2: EACH BOARD WILL SECURE TO THE FORT USING TWO 5/16 X 4-1/2" HEX BOLTS WITH 5/16" WASHERS IN THE TOPMOST HOLES, FOLLOWED BY TWO 5/16 X 3-1/2" LAG SCREWS WITH 5/16" WASHERS IN THE BOTTOM HOLES.

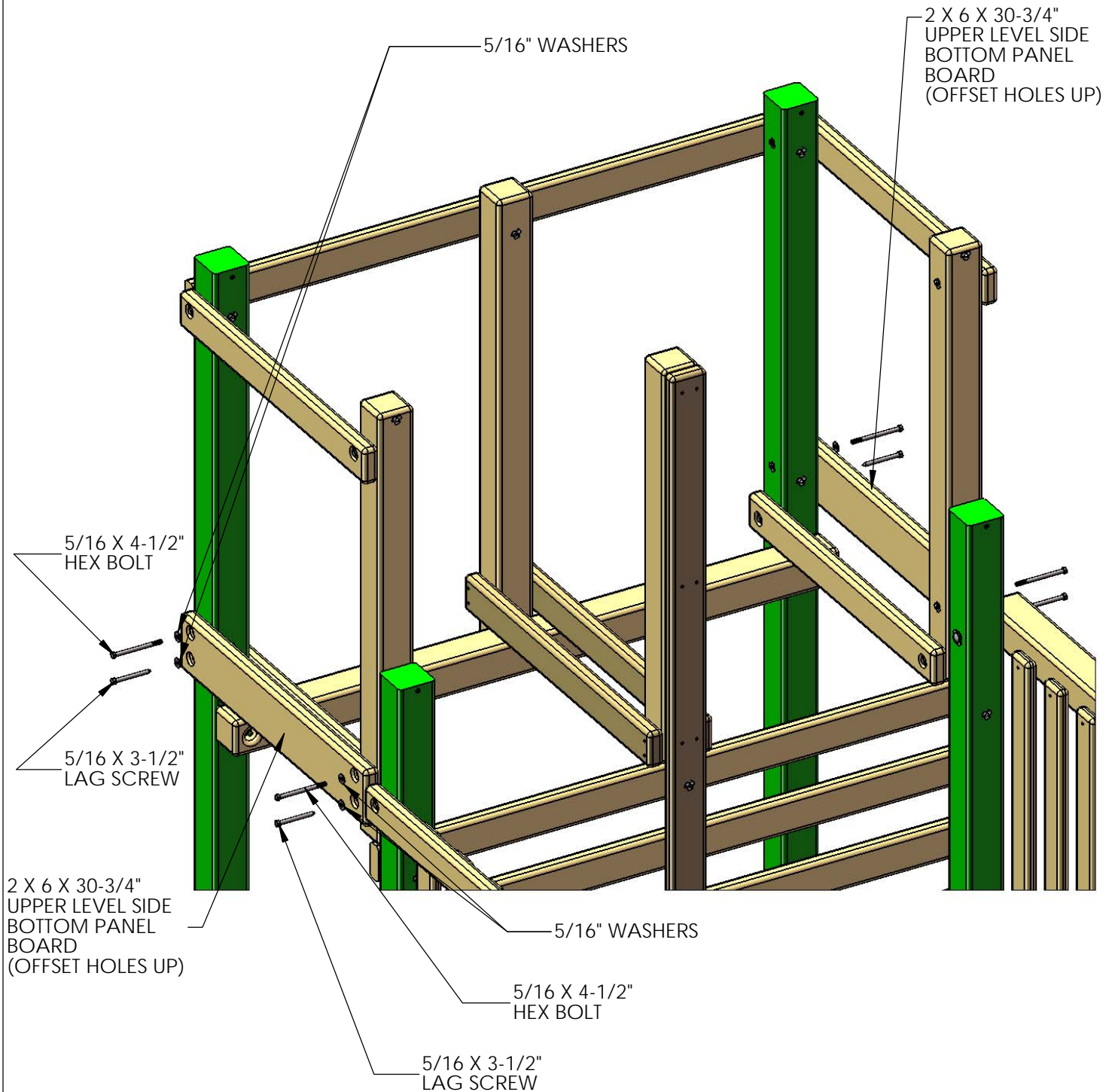

## STEP 48: UPPER LEVEL BOTTOM PANEL BOARD

1: ONE 2 X 6 X 30-3/4" UPPER LEVEL BOTTOM PANEL BOARD IS USED IN THIS STEP, OFFSET HOLES DOWN, ON THE REAR OF THE FORT. LINE UP THE TOP HOLE OF THE UPPER LEVEL BOTTOM PANEL BOARD WITH THE HOLE IN THE CORNER POST.

2: THE BOARD WILL SECURE TO THE FORT USING ONE 5/16 X 4-1/2" HEX BOLT WITH A 5/16" WASHER, FOLLOWED BY ONE 5/16 X 3-1/2" LAG SCREW WITH A 5/16" WASHER. USE A LEVEL TO MAKE SURE THE BOARD IS INSTALLED PROPERLY.

3: NO HARDWARE WILL BE USED ON THE SIDE AT THE CENTER POST AT THIS TIME.

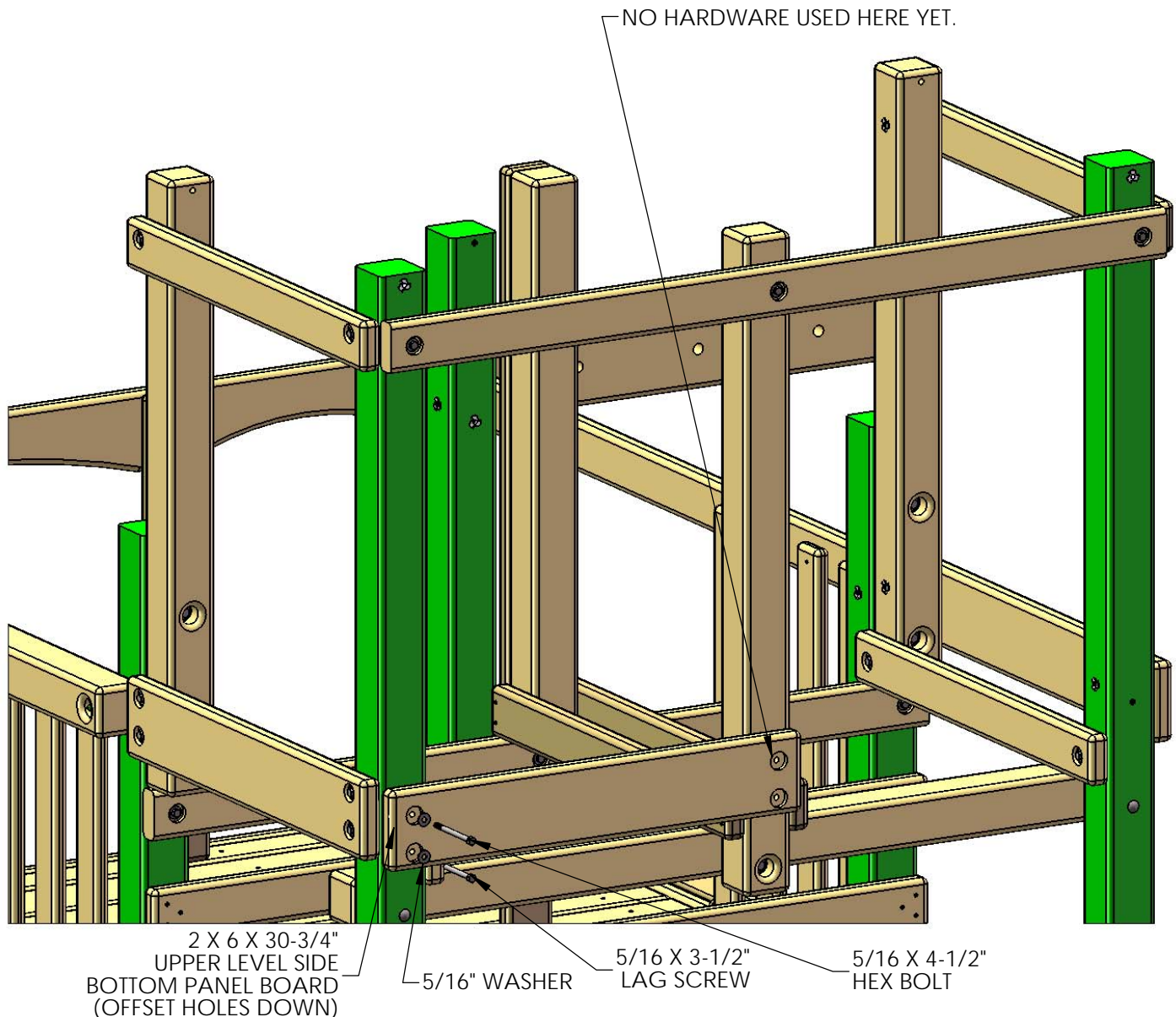

## STEP 49: UPPER LEVEL DECK

THE FOLLOWING STEP IS RECOMMENDED TO PREVENT POSSIBLE SPLITS IN THE WOOD

1: PRE-DRILL THE ENDS OF THE DECK BOARDS TO PREVENT INSTALLATION DAMAGE. PRE-DRILL BOTH ENDS WITH A  $\frac{1}{8}$ " DRILL BIT AT THE DIMENSIONS SHOWN BELOW.

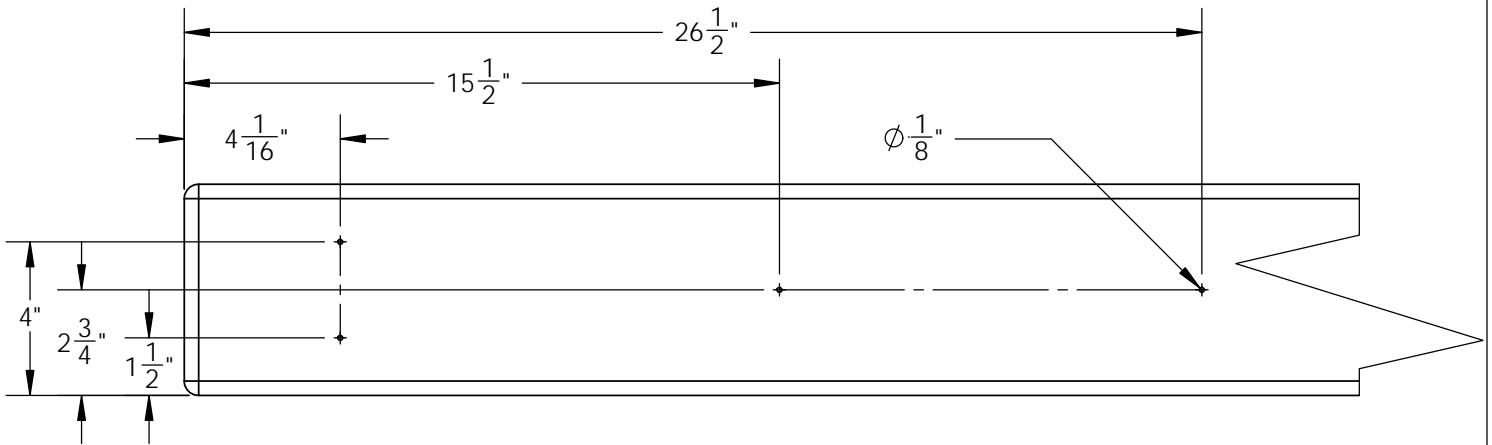

2: START WITH A  $5/4 \times 6 \times 58$ " DECK BOARD AT ONE END OF THE FORT. CENTER THE BOARD BETWEEN THE UPPER LEVEL BOTTOM PANEL BOARDS AND LEAVE A UNIFORM SPACE BETWEEN THE DECK BOARDS. LAY ALL DECK BOARDS ACROSS THE DECK SUPPORTS BEFORE SECURING THEM TO THE FORT. THIS WILL ENSURE THAT YOU HAVE EQUAL SPACING ACROSS THE DECK.

3: FIND TWO  $2 \times 4 \times 30\text{-}3/4$ " UPPER LEVEL CENTER DECK SUPPORTS AND CENTER THEM ON THE HOLES DRILLED AT  $15\text{-}1/2$ " UNDERNEATH THE DECK BOARDS. ATTACH THE DECK BOARDS WITH  $2$ " WOOD SCREWS THROUGH THE PRE-DRILLED HOLES.

NOTE: THE TOP OF THE SCREW HEAD SHOULD BE FLUSH TO THE TOP OF THE DECK BOARDS.

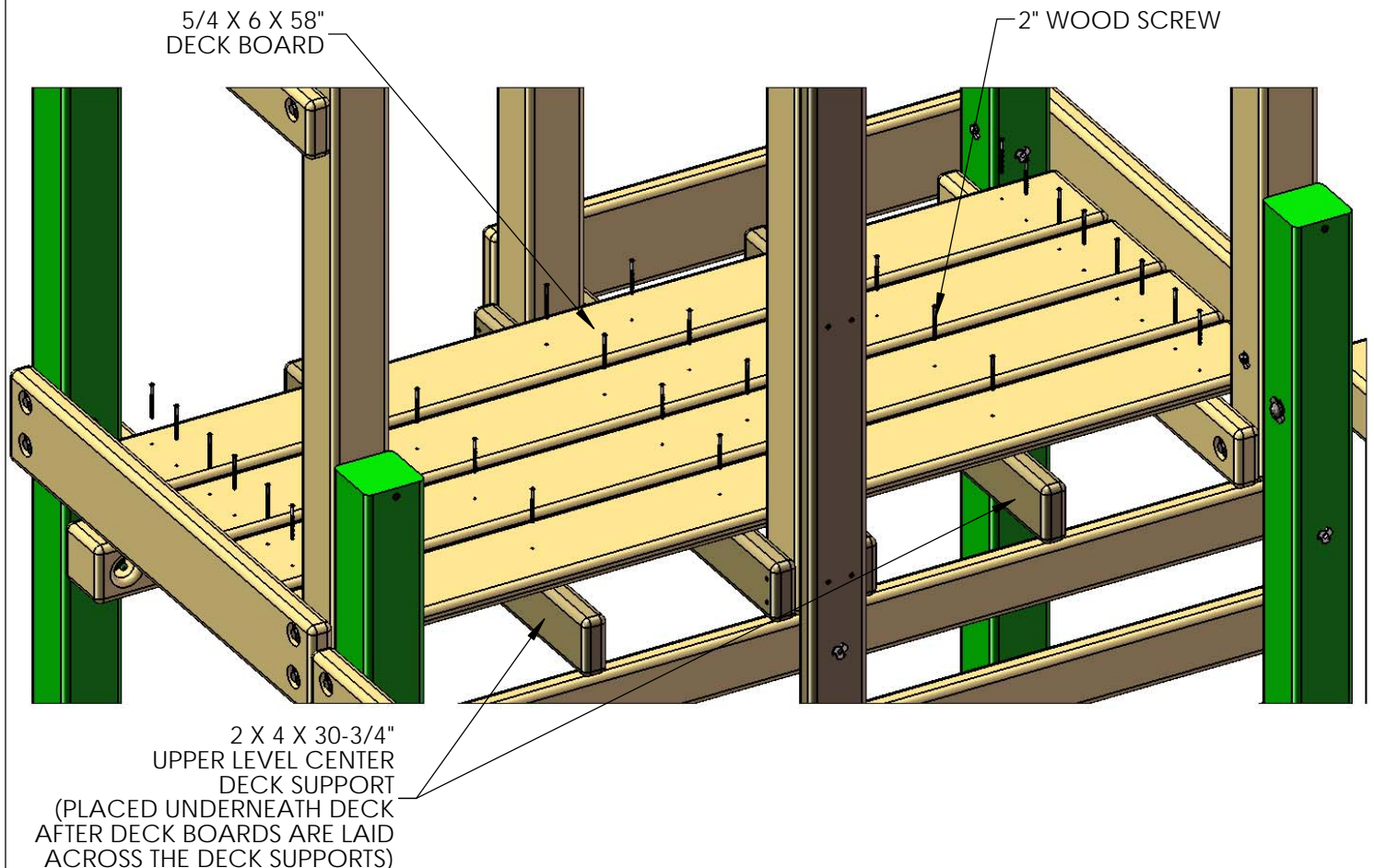

## STEP 50: UPPER LEVEL DECK SPACERS

THE FOLLOWING STEP IS RECOMMENDED TO PREVENT POSSIBLE SPLITS IN THE WOOD

1: PRE-DRILL THE ENDS OF THE DECK SPACERS TO PREVENT INSTALLATION DAMAGE. PRE-DRILL BOTH ENDS WITH A 1/8" DRILL BIT AT THE DIMENSIONS SHOWN BELOW.

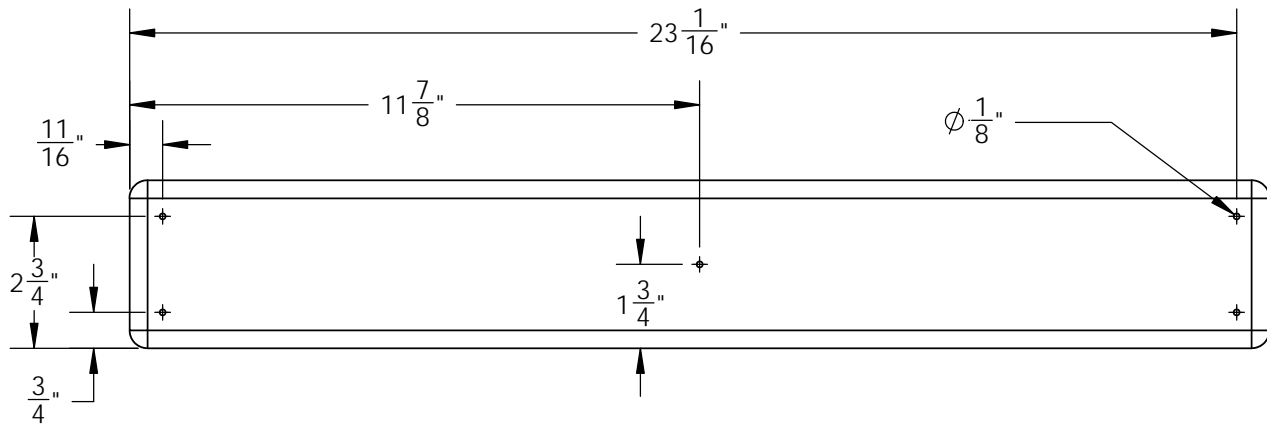

2: FOUR  $5/4 \times 4 \times 23\text{-}3/4$ " DECK SPACERS WILL FIT AT EACH END OF THE DECK BETWEEN THE CORNER AND CENTER POSTS. ATTACH THE DECK SPACERS WITH 2" WOOD SCREWS THROUGH THE PRE-DRILLED HOLES.

NOTE: THE TOP OF THE SCREW HEAD SHOULD BE FLUSH TO THE TOP OF THE DECK SPACERS.

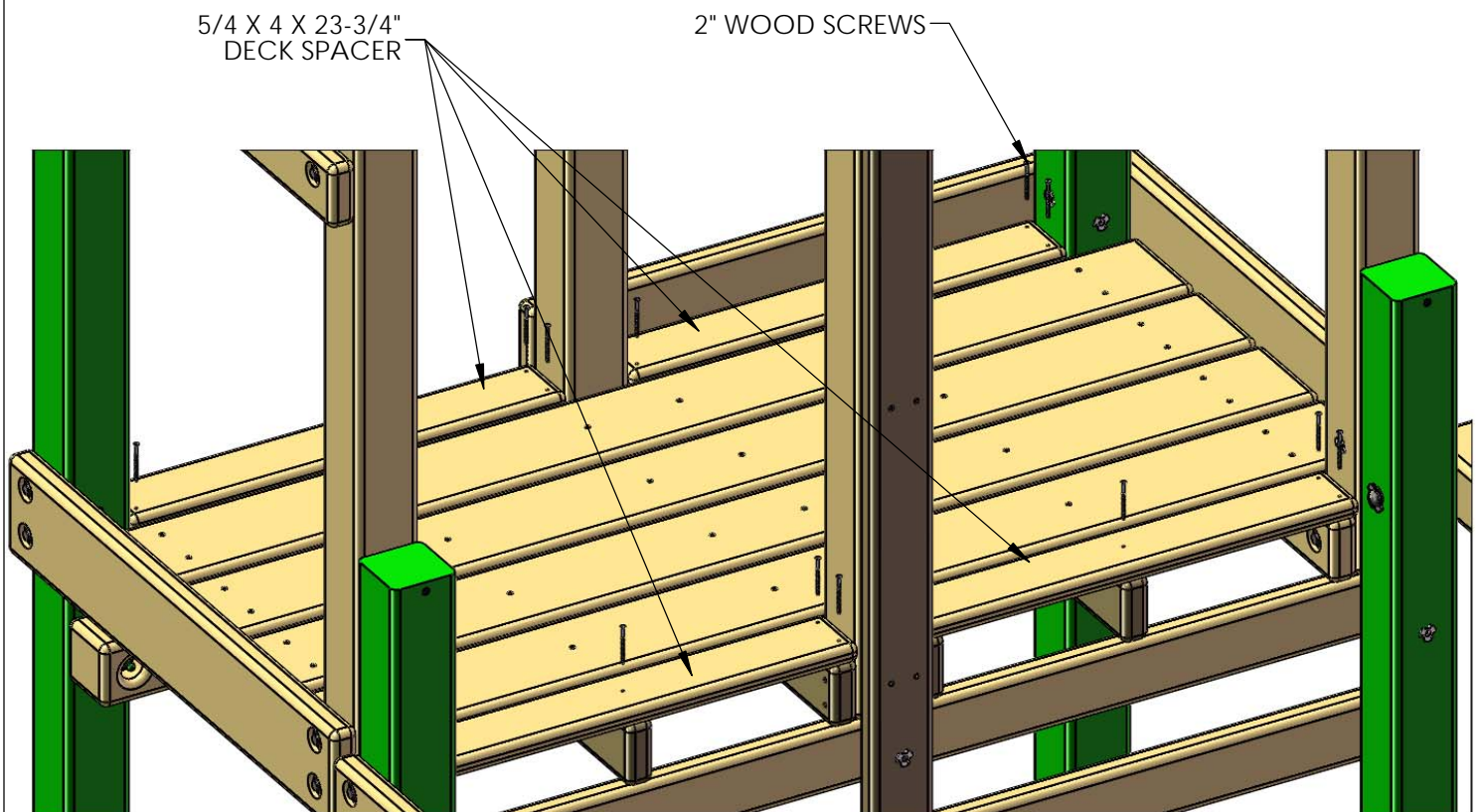

## STEP 51: UPPER LEVEL PANEL SLATS

THE FOLLOWING STEP IS RECOMMENDED TO PREVENT POSSIBLE SPLITS IN THE WOOD

1: PRE-DRILL THE ENDS OF THE PANEL SLATS TO PREVENT INSTALLATION DAMAGE. PRE-DRILL BOTH ENDS WITH A 1/8" DRILL BIT AT THE DIMENSIONS SHOWN BELOW.

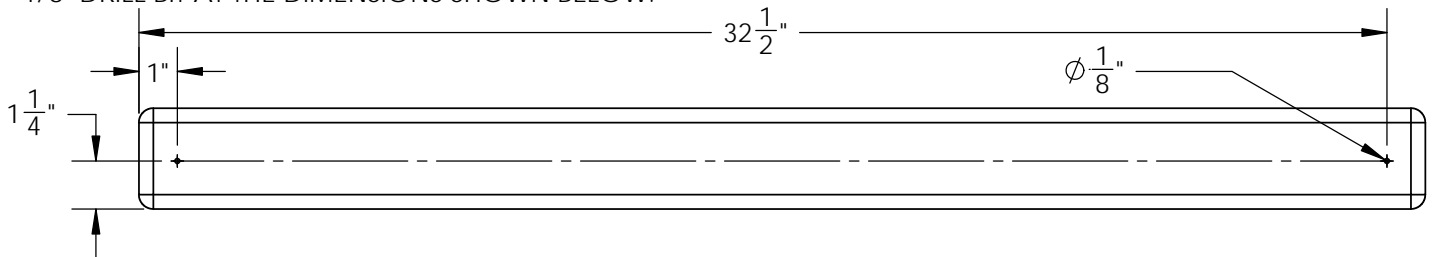

- 2: TWELVE 5/4 X 3 X 33-1/2" PANEL SLATS WILL ENCLOSE THE UPPER LEVEL OF THE FORT.
- 3: THE SIDE WALLS WILL HAVE FOUR SLATS; CENTERED OVER EACH DECK BOARD.
- 4: THE BACK WALL WILL ALSO HAVE FOUR SLATS, USING ONE SLAT FOR SPACING (2-5/8")
- 5: SECURE ALL WALL SLATS WITH 2" WOOD SCREWS THROUGH THE PRE-DRILLED HOLES.

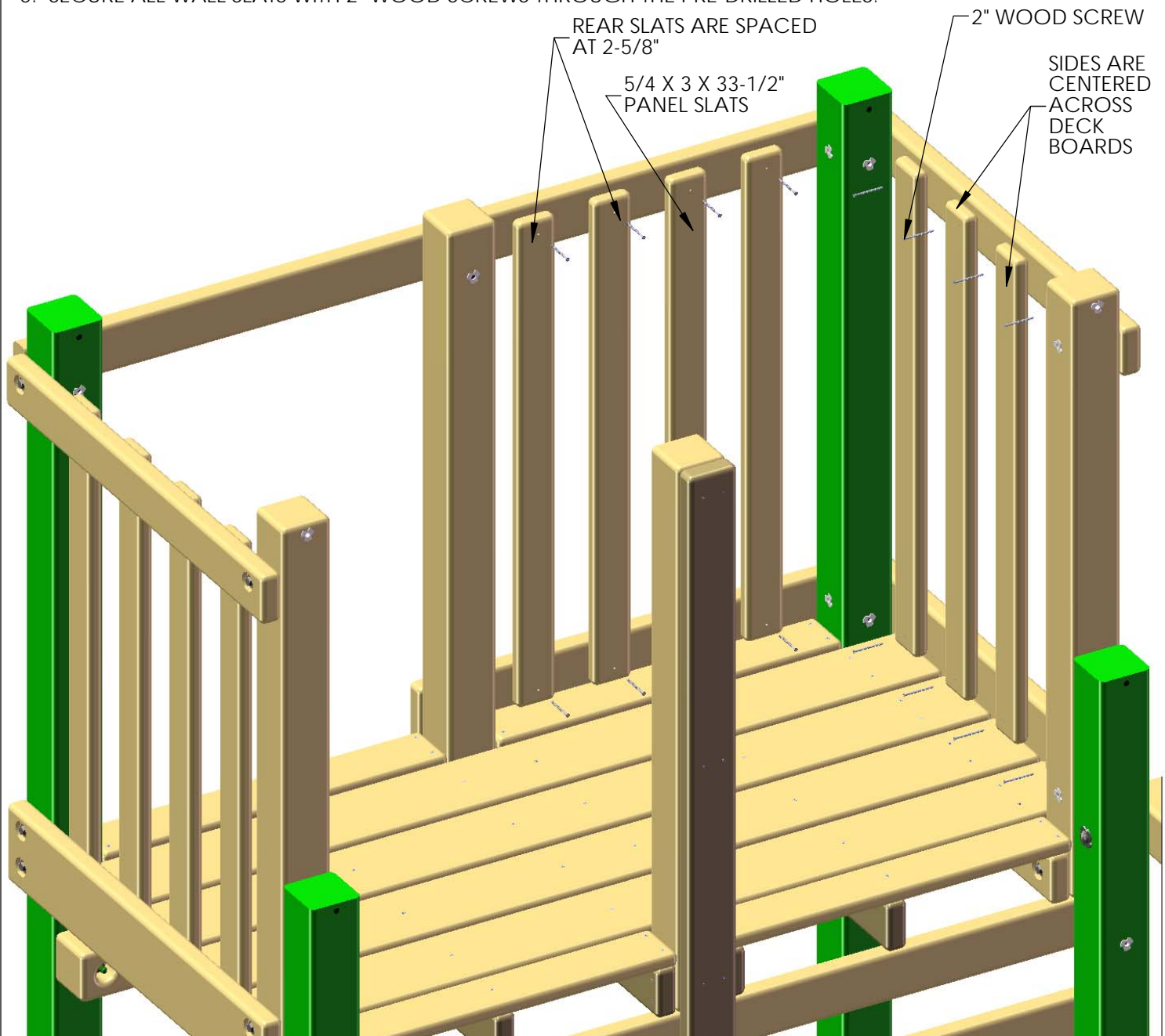

## STEP 52: UPPER LEVEL ROOF SUPPORTS

1: WITH OFFSET HOLES DOWN, ATTACH THE 2 X 4 X 43" ROOF SUPPORTS TO THE FORT WITH 5/16 X 4-1/2" HEX BOLTS AND 5/16" WASHERS. THE ROOF SUPPORTS SHOULD MEET IN THE MIDDLE TO FORM A RIGHT ANGLE.

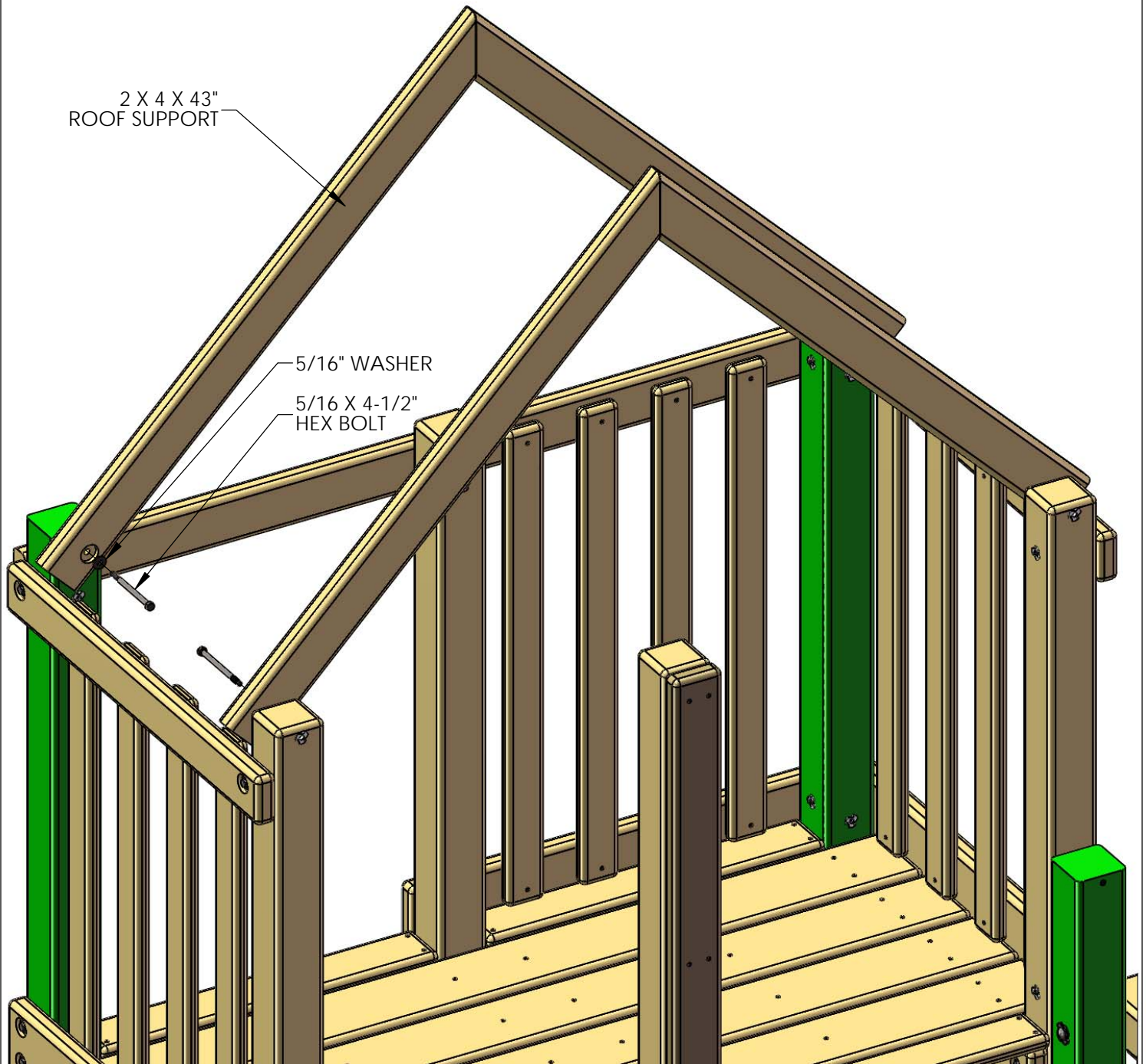

# STEP 53: ROOF BOARDS

THE FOLLOWING STEP IS RECOMMENDED TO PREVENT POSSIBLE SPLITS IN THE WOOD

1: PRE-DRILL THE ENDS OF THE ROOF BOARDS TO PREVENT INSTALLATION DAMAGE. PRE-DRILL BOTH ENDS WITH A 1/8" DRILL BIT AT THE DIMENSIONS SHOWN BELOW.

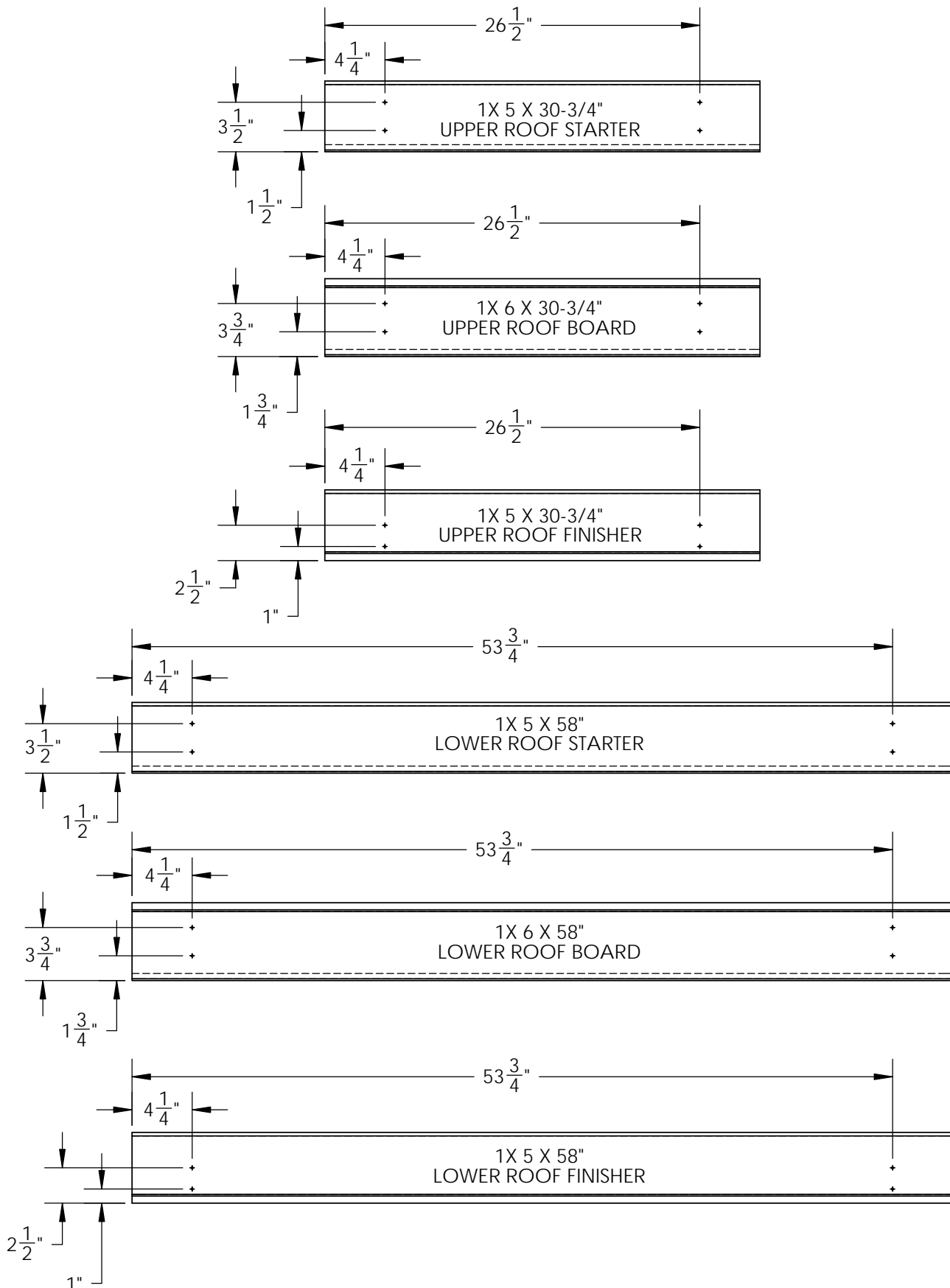



## STEP 54: UPPER LEVEL ROOF

- 1: PLACE THE 1 X 5 X 30-3/4" GROOVE-ONLY ROOF STARTER BOARDS AT THE PEAK OF THE ROOF. THE HOLES IN THE ROOF STARTERS SHOULD BE CENTERED ON THE ROOF SUPPORTS, AND THE SMOOTH ENDS OF THE ROOF STARTERS SHOULD BE PLACED AS CLOSE TO EACH OTHER AS POSSIBLE WITHOUT THE BOARDS OVERLAPPING.
- 2: FASTEN THE ROOF STARTER BOARDS TO THE ROOF SUPPORTS WITH 1-1/2" WOOD SCREWS.

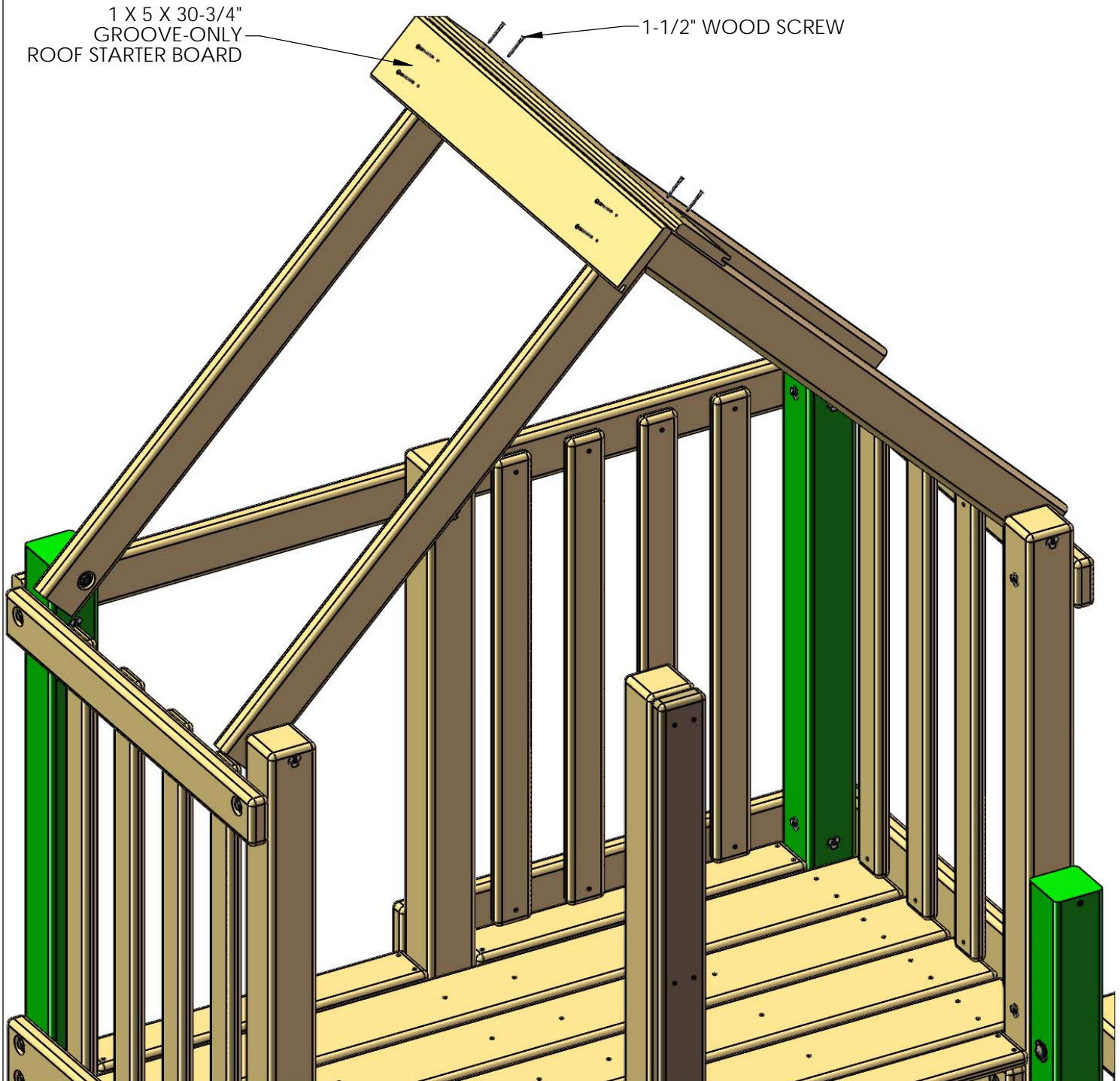

## STEP 55: UPPER LEVEL ROOF

- 1: PLACE THE 30-3/4" ROOF PEAK ON TOP OF THE ROOF STARTER BOARDS.
- 2: FASTEN THE ROOF PEAK TO THE ROOF STARTER BOARDS WITH 1-1/2" WOOD SCREWS.

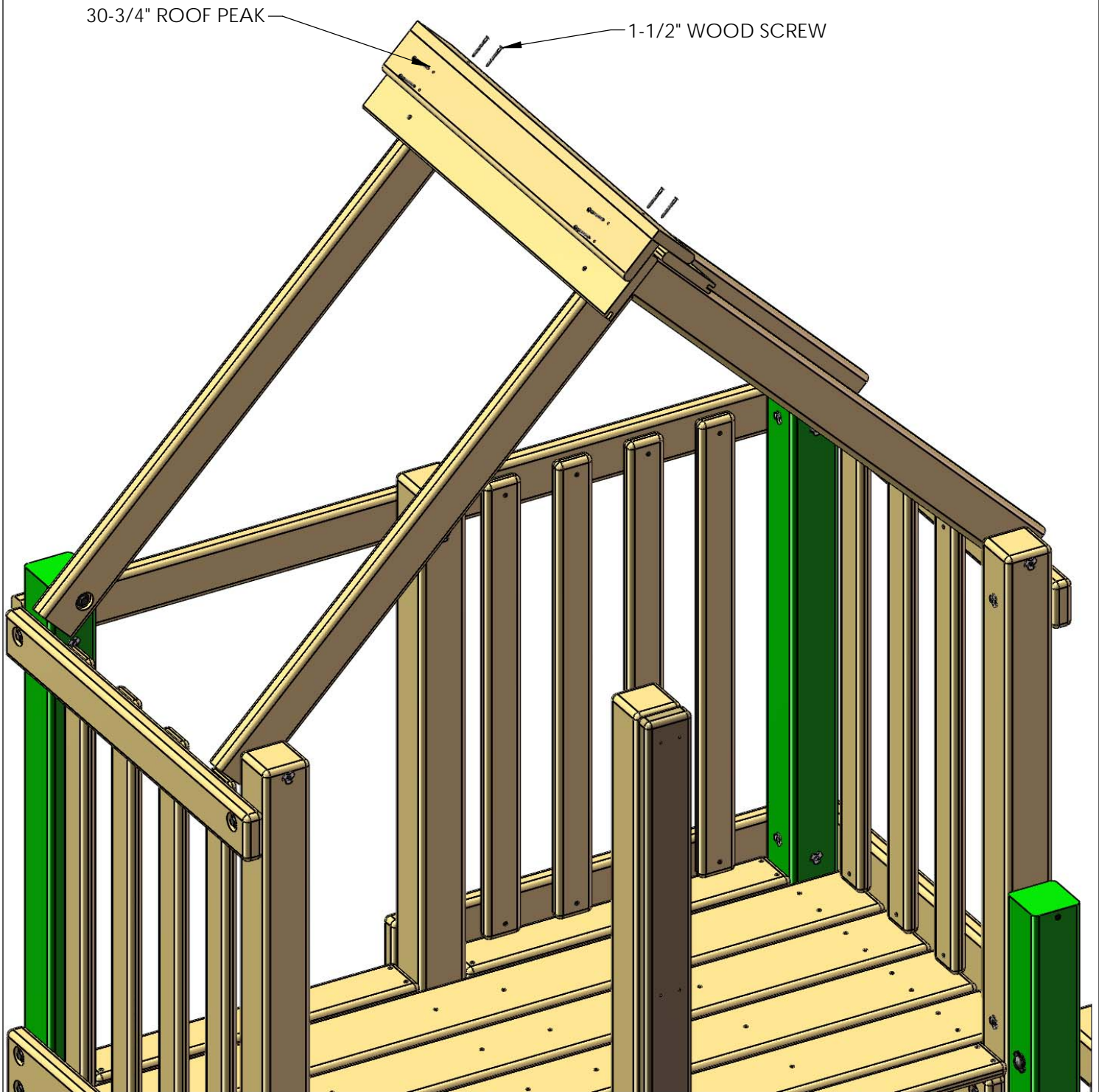

## STEP 56: UPPER LEVEL ROOF PEAK SUPPORTS

1: PRE-DRILL HOLES IN THE FOUR 5/4 X 10" ROOF PEAK SUPPORTS TO THE PATTERN SHOWN BELOW WITH A 1/8" DRILL BIT.

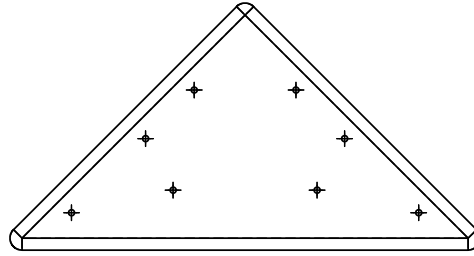

2: PLACE TWO OF THE 5/4 X 10" ROOF PEAK SUPPORTS AGAINST THE ANGLED ROOF SUPPORTS AND UNDERNEATH THE ROOF BOARDS. FASTEN THE ROOF PEAK SUPPORTS TO THE ANGLED ROOF SUPPORTS WITH 1-1/2" WOOD SCREWS.

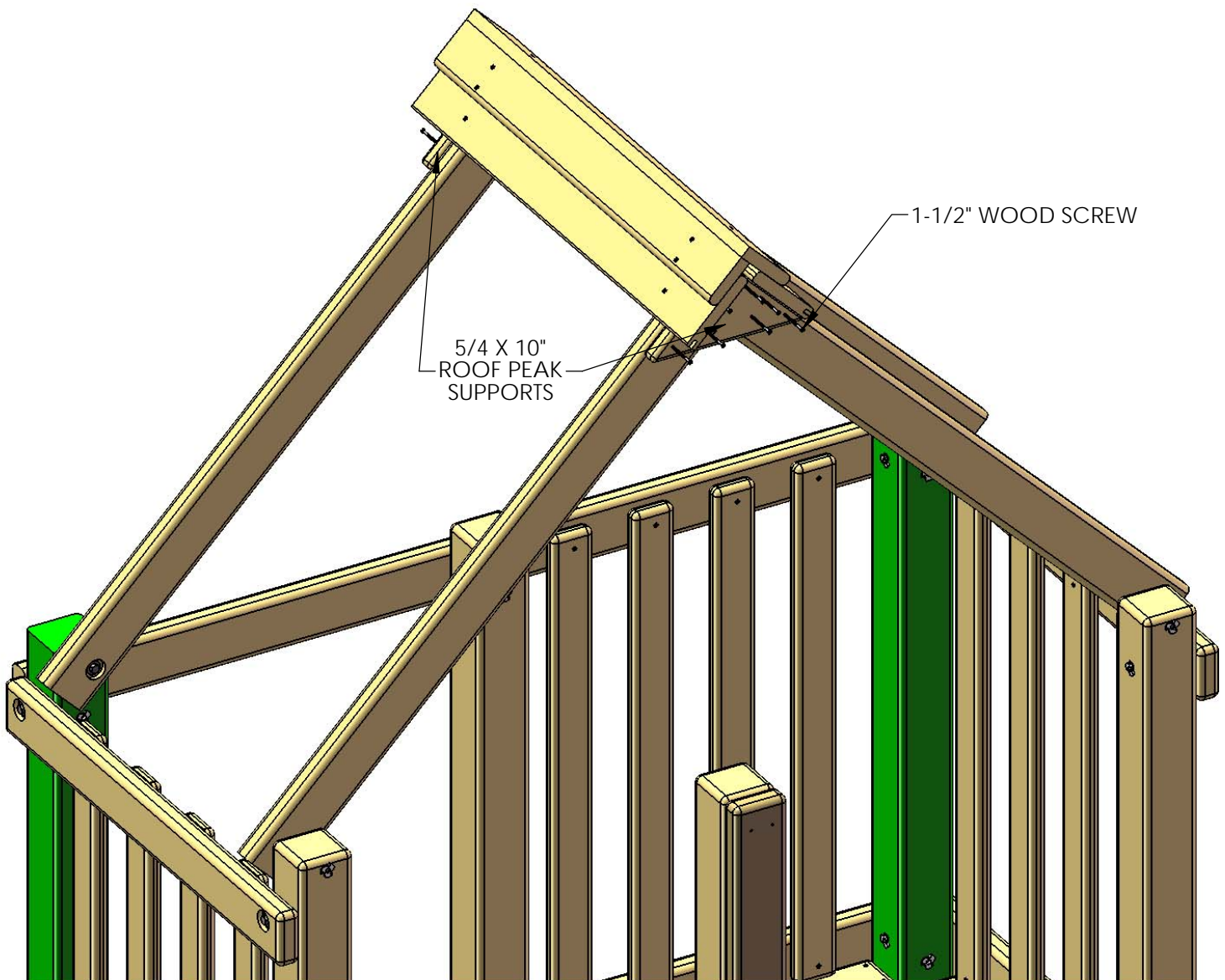

## STEP 57: FINAL UPPER PANEL BOARD OF UPPER DECK

1: INSIDE THE FORT, AGAINST THE TWO LAG POSTS, FLUSH TO THE TOP OF THE LOWER LEVEL REAR CENTER POST, MOUNT THE 2 X 4 X 58" 3-HOLE TOP PANEL BOARD (OFFSET DOWN) WITH 5/16 X 3-1/2" LAG SCREWS AND 5/16" WASHERS.

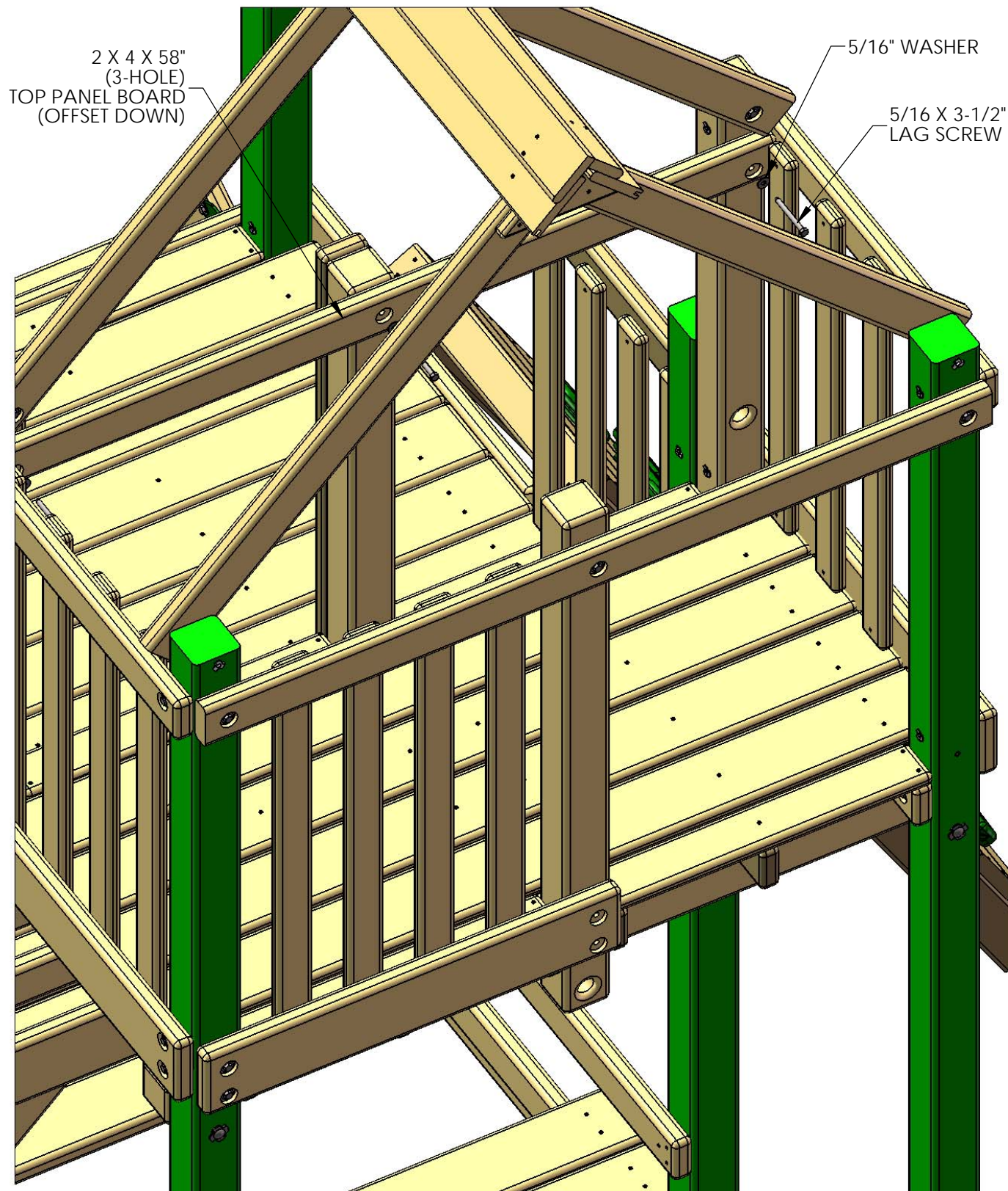

## STEP 58: SUNBURST

1: PRE-DRILL HOLES IN THE THREE 2 X 6 X 16" SUNS TO THE PATTERN SHOWN BELOW WITH A 1/8" DRILL BIT.

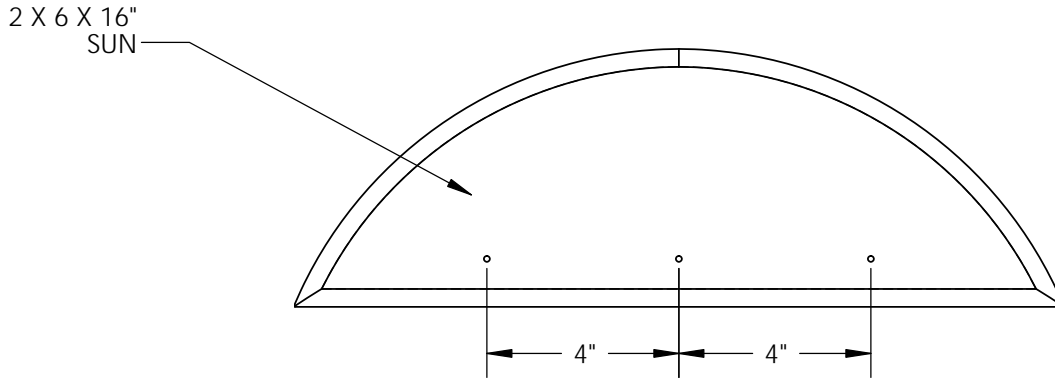

2: PLACE THE 2 X 6 X 16" SUN CENTERED AGAINST THE 5/4 X 2-5/8 X 42" SUN SUPPORT. FASTEN THE SUN TO THE SUN SUPPORT WITH 2" WOOD SCREWS. REPEAT THIS PROCESS TWO MORE TIMES. WHEN YOU ARE FINISHED, YOU SHOULD HAVE THREE ASSEMBLIES SIMILAR TO THE ONE SHOWN BELOW.

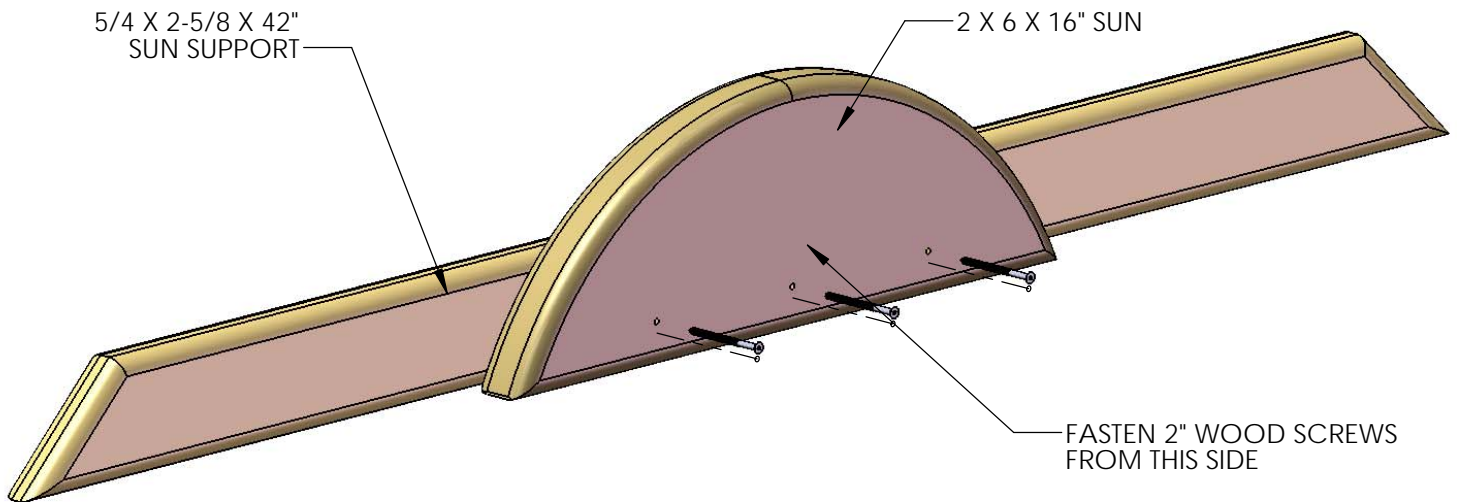

NOTE: THE TOP OF THE SCREW HEAD SHOULD BE FLUSH TO THE SURFACE OF THE SUN.

3: PRE-DRILL HOLES IN EACH END OF THE THREE 5/4 X 2 X 16" LARGE RAYS, AND THE EIGHTEEN 5/4 X 2 X 10" SMALL RAYS TO THE PATTERN SHOWN BELOW WITH A 1/8" DRILL BIT.

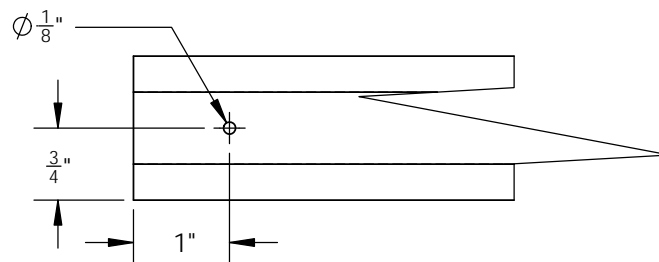

## STEP 59: UPPER LEVEL SUNRAY

1: PLACE THE SUNBURST ASSEMBLY MADE IN THE PREVIOUS STEP AGAINST THE ANGLED ROOF SUPPORTS ONTO THE OUTSIDE OF THE FORT, FLUSH TO THE TOP OF THE ANGLED ROOF SUPPORTS. MAKE SURE THE ASSEMBLY IS LEVEL BEFORE PROCEEDING TO THE NEXT STEP.

2: FASTEN THE SUNBURST ASSEMBLY TO THE ROOF SUPPORTS WITH 2" WOOD SCREWS.

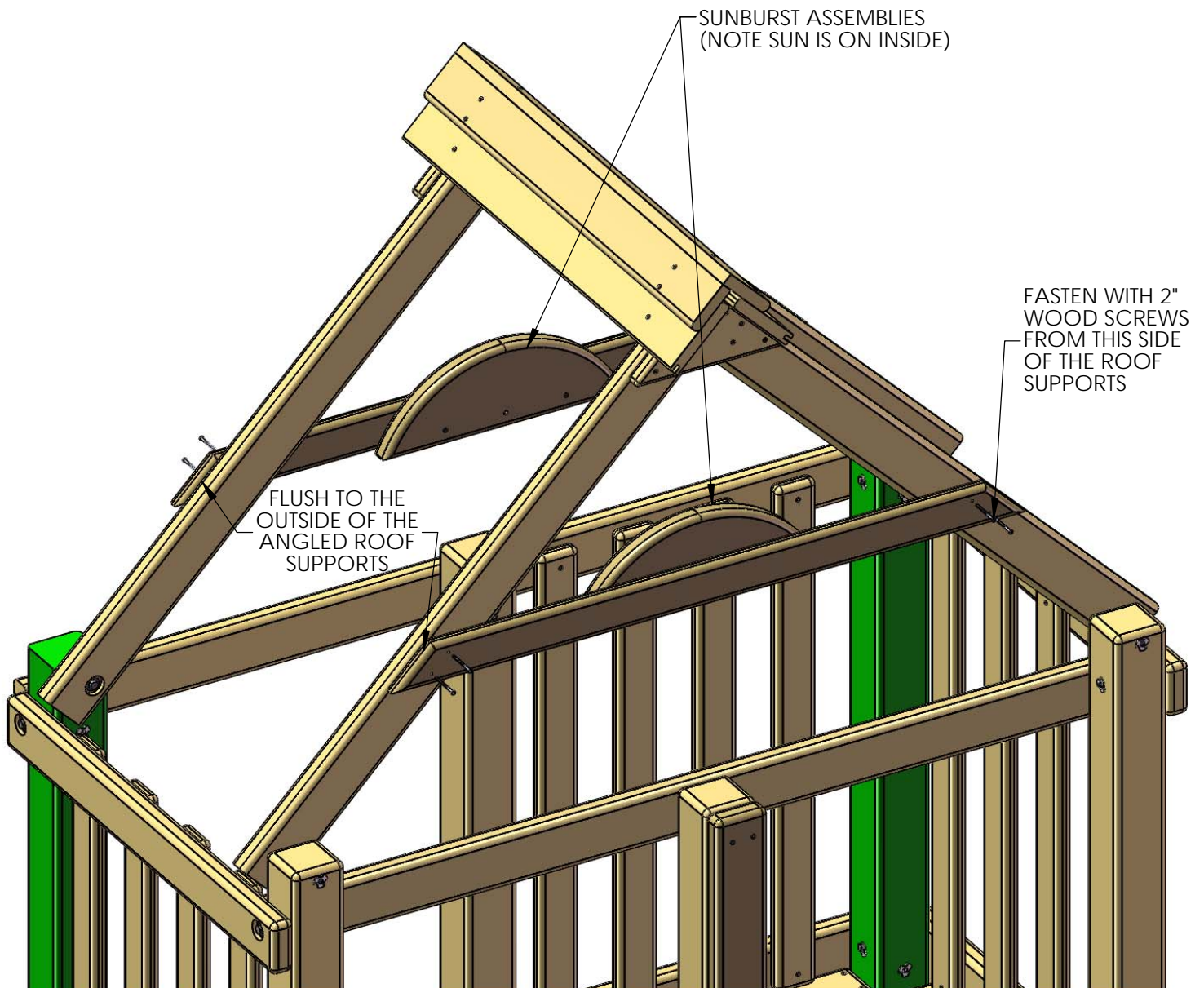

## STEP 60: UPPER LEVEL SUNRAY

- 1: CENTER THE 5/4 X 2 X 16" LARGE RAY ONTO THE HALF SUN AND THE ROOF SUPPORTS AND FASTEN WITH TWO 1-1/2" SCREWS.
- 2: EQUALLY SPACE THE SMALL RAYS ABOUT THE HALF SUN (THREE ON EACH SIDE OF LARGE RAY) AND MARK THE POSITION OF THE SMALL SUNRAYS WITH A PENCIL.
- 3: SECURE THE SMALL SUNRAYS ONE AT A TIME TO THE HALF SUN AND ROOF SUPPORTS. LINE EACH SUNRAY UP WITH THE MARKS DRAWN. FASTEN THE SMALL SUNRAYS WITH TWO 1-1/2" WOOD SCREWS EACH. REPEAT ON OTHER SIDE OF FORT.

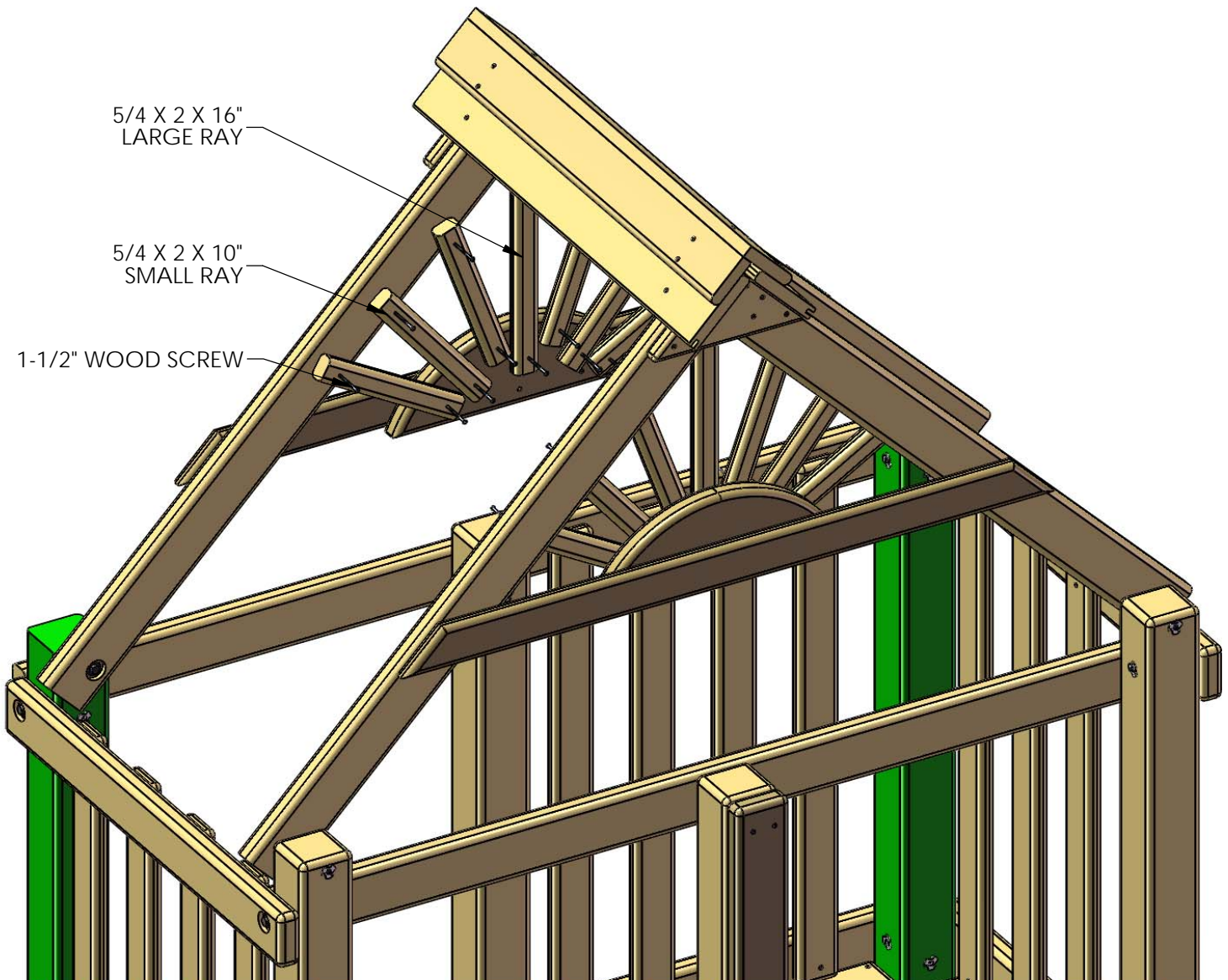

## STEP 61: UPPER LEVEL ROOF

- 1: PLACE THE 1 X 6 X 30-3/4" ROOF BOARDS ON TOP OF THE ROOF SUPPORTS, FITTING THE TONGUE END INTO THE GROOVE END OF THE ROOF STARTERS. EACH SIDE OF THE ROOF GETS SEVEN ROOF BOARDS.
- 2: FASTEN THE ROOF BOARDS TO THE ROOF SUPPORTS WITH 1-1/2" WOOD SCREWS.
- 3: PLACE A 1 X 5 X 30-3/4" ROOF FINISHER ON THE ENDS OF THE ROOF ASSEMBLY AND FASTEN WITH 1-1/2" WOOD SCREWS.

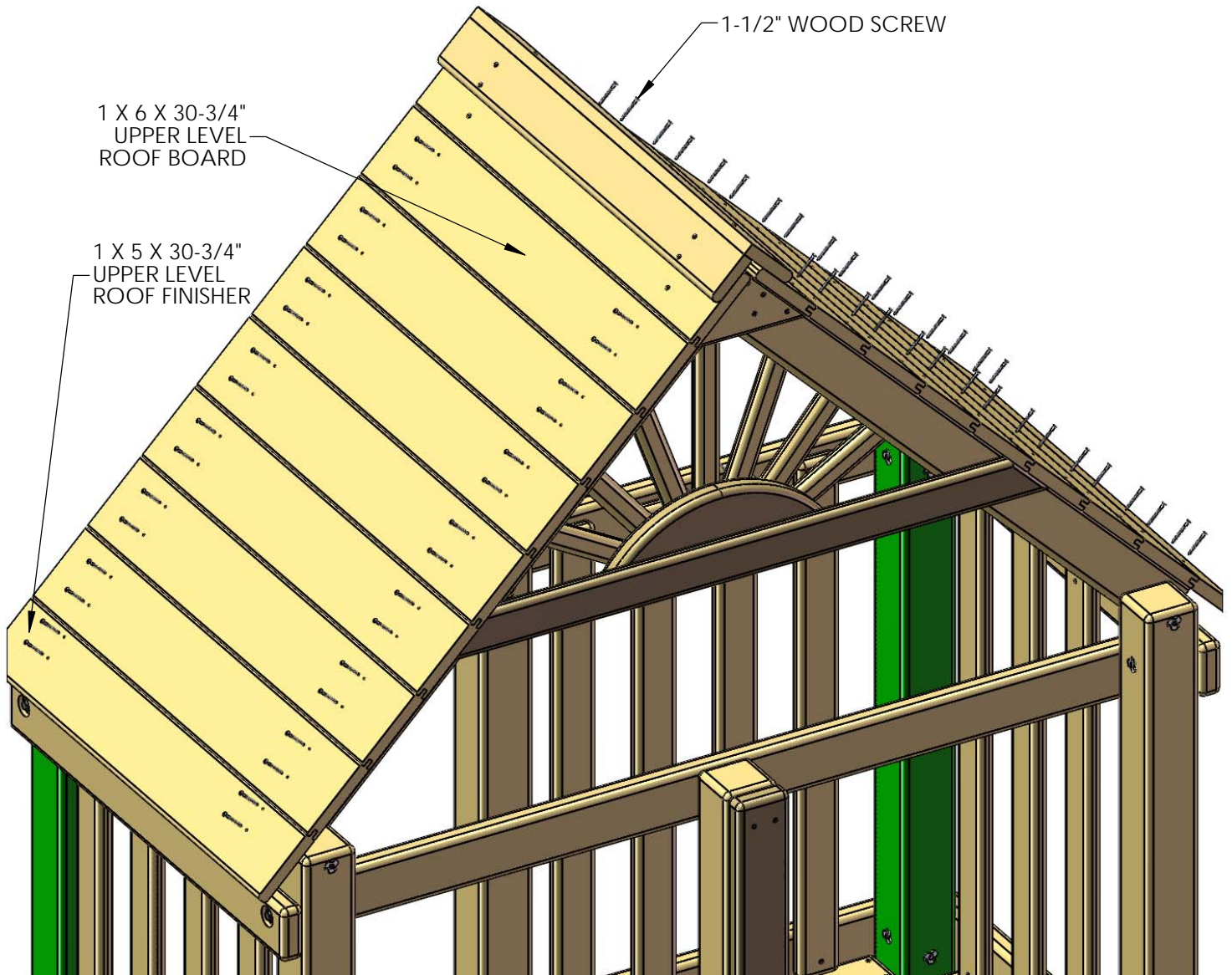



## STEP 62: LOWER LEVEL ROOF

1: WITH OFFSET HOLES DOWN, ATTACH THE 2 X 4 X 43" ROOF SUPPORTS TO THE LOWER LEVEL CORNER POSTS WITH 5/16 X 4-1/2" HEX BOLTS AND 5/16" WASHERS. THE ROOF SUPPORTS SHOULD MEET IN THE MIDDLE TO FORM A RIGHT ANGLE.

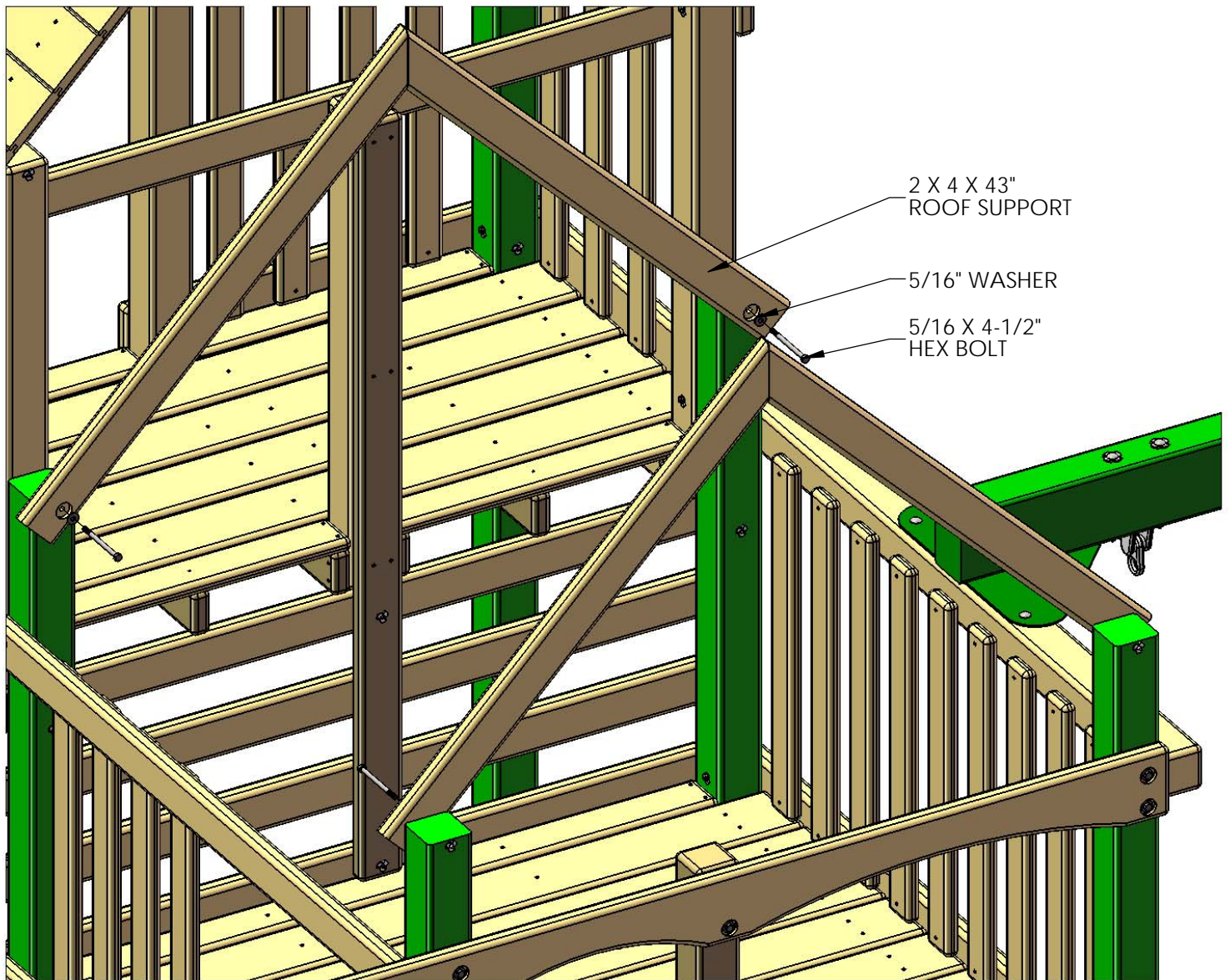

## STEP 63: LOWER LEVEL ROOF

- 1: PLACE THE 1 X 5 X 58" GROOVE-ONLY ROOF STARTER BOARDS AT THE PEAK OF THE ROOF. THE HOLES IN THE ROOF STARTERS SHOULD BE CENTERED ON THE ROOF SUPPORTS, AND THE SMOOTH ENDS OF THE ROOF STARTERS SHOULD BE PLACED AS CLOSE TO EACH OTHER AS POSSIBLE WITHOUT THE BOARDS OVERLAPPING.
- 2: FASTEN THE ROOF STARTER BOARDS TO THE ROOF SUPPORTS WITH 1-1/2" WOOD SCREWS.

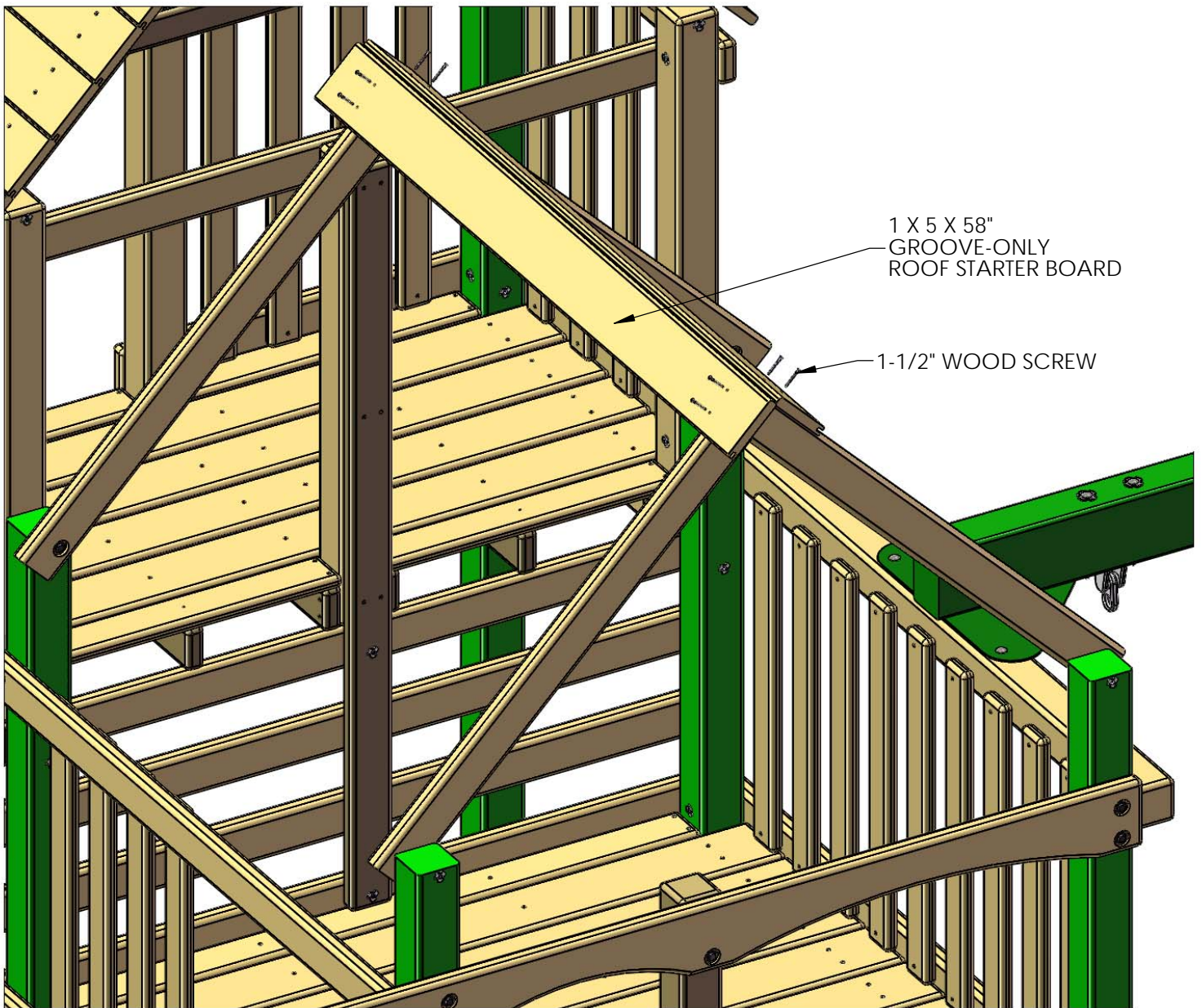

## STEP 64: LOWER LEVEL ROOF

- 1: PLACE THE 58" ROOF PEAK ON TOP OF THE ROOF STARTER BOARDS.
- 2: FASTEN THE ROOF PEAK TO THE ROOF STARTER BOARDS WITH 1-1/2" WOOD SCREWS.

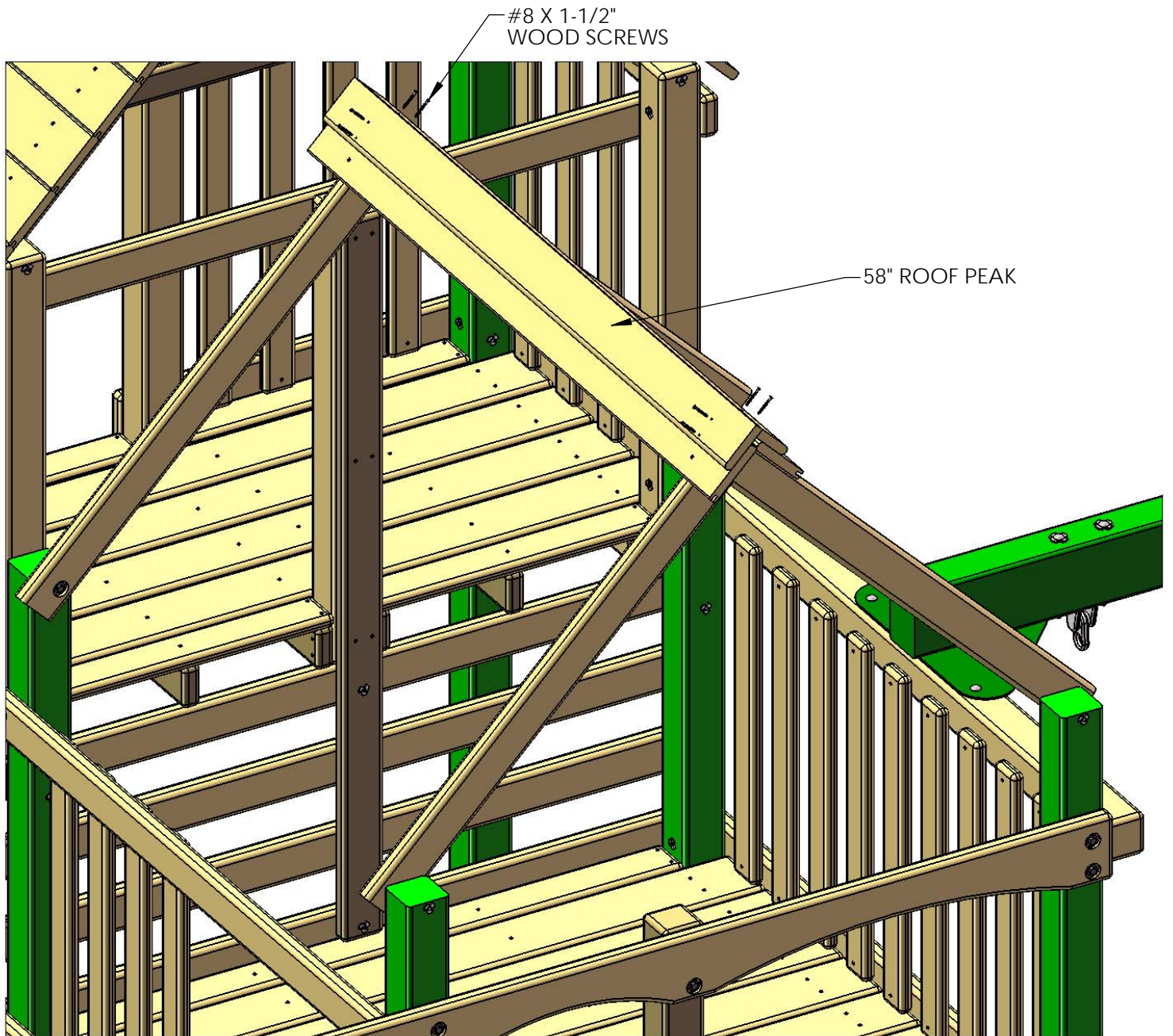

## STEP 65: LOWER LEVEL ROOF PEAK SUPPORTS

1: PLACE THE TWO REMAINING 5/4 X 10" ROOF PEAK SUPPORTS AGAINST THE ANGLED ROOF SUPPORTS AND UNDERNEATH THE ROOF BOARDS. FASTEN THE ROOF PEAK SUPPORTS TO THE ANGLED ROOF SUPPORTS WITH 1-1/2" WOOD SCREWS.

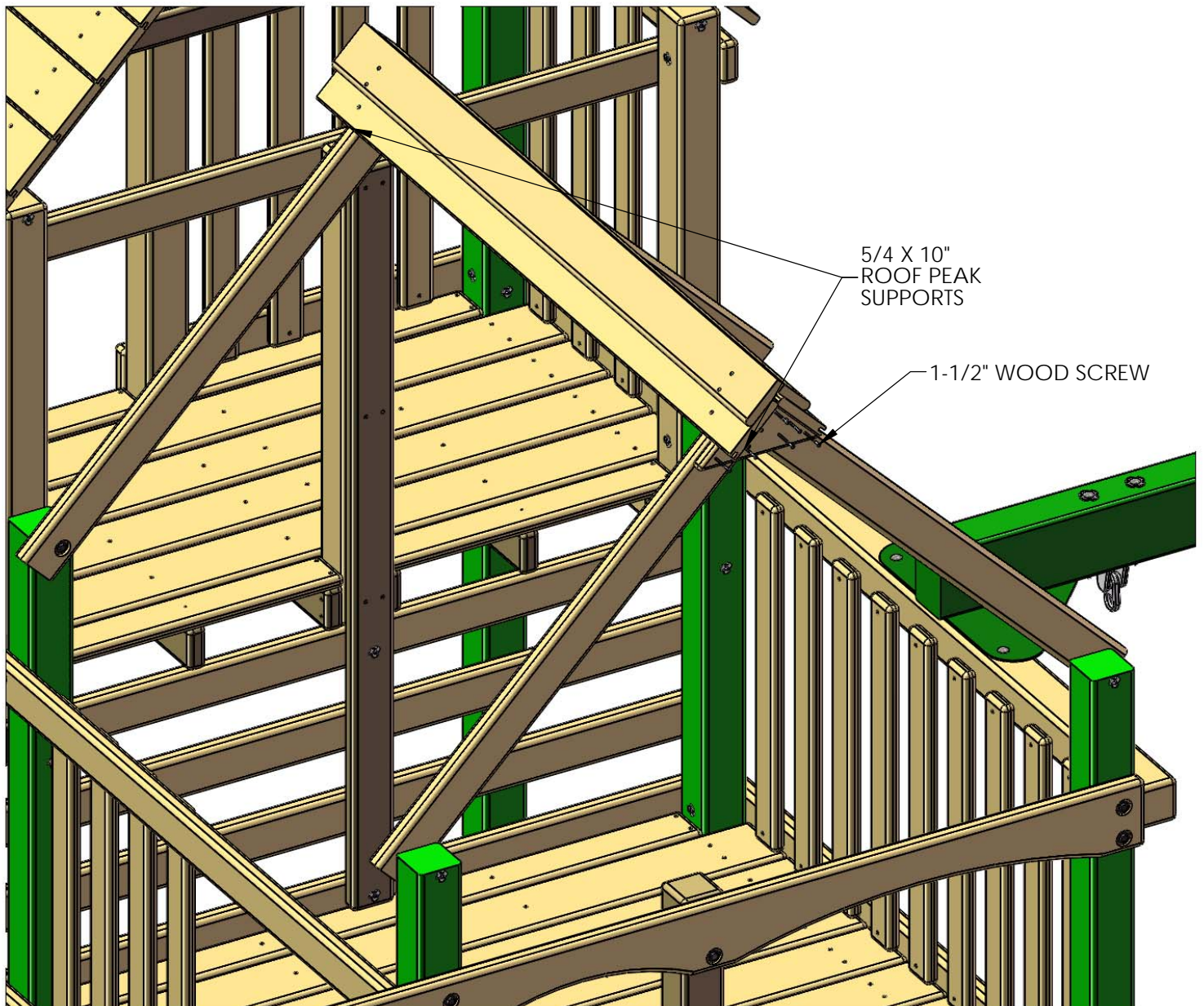

## STEP 66: LOWER LEVEL SUNRAY

- 1: PLACE THE REMAINING SUNBURST ASSEMBLY MADE IN STEP 58 AGAINST THE ANGLED ROOF SUPPORTS ONTO THE OUTSIDE OF THE FORT, FLUSH TO THE TOP OF THE ANGLED ROOF SUPPORTS. MAKE SURE THAT THE SUNBURST ASSEMBLY IS LEVEL BEFORE PROCEEDING TO THE NEXT STEP.
- 2: FASTEN THE SUNBURST ASSEMBLY TO THE ROOF SUPPORTS WITH 2" WOOD SCREWS.

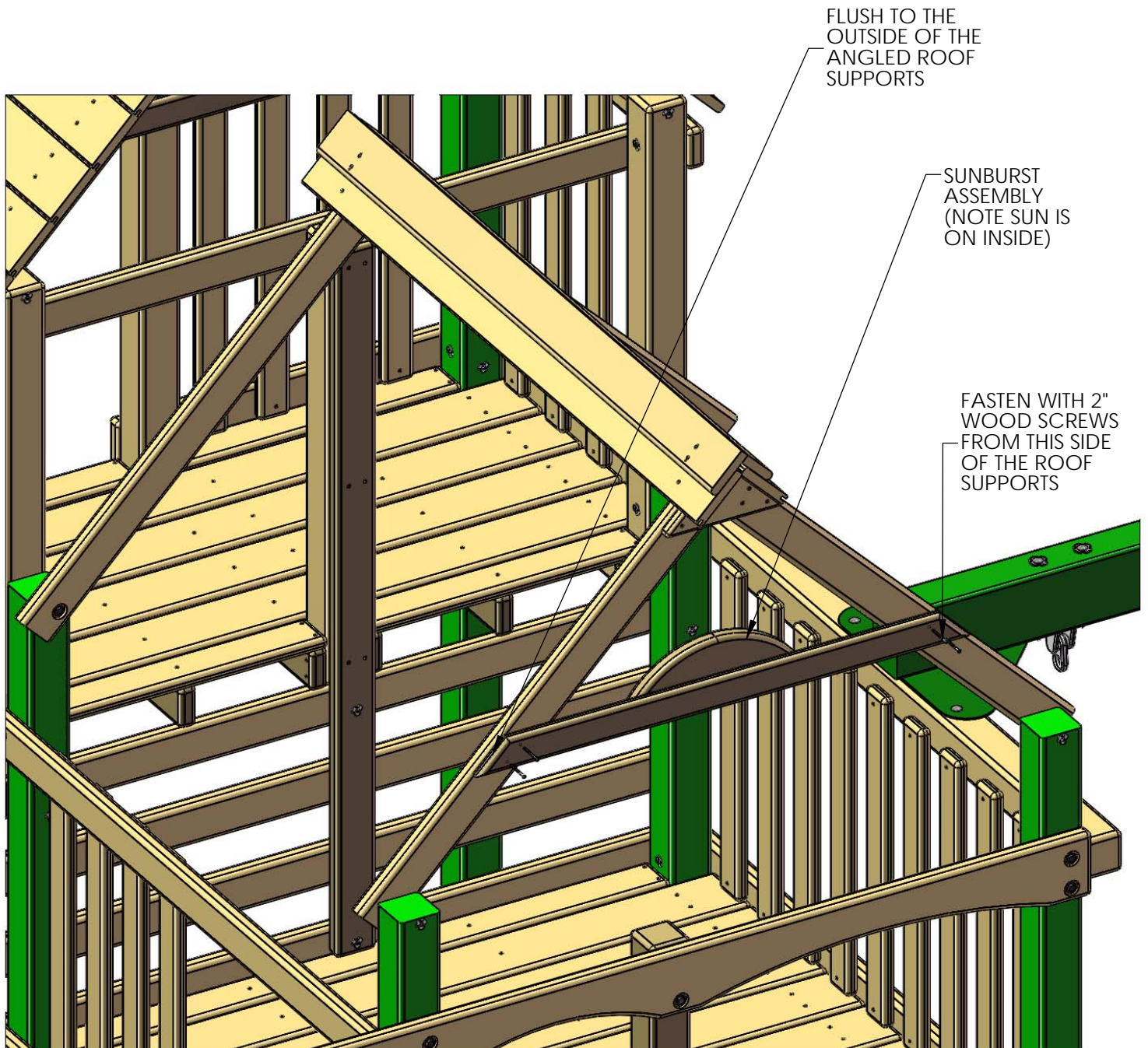

## STEP 67: LOWER LEVEL SUNRAY

- 1: CENTER THE 5/4 X 2 X 16" LARGE RAY ONTO THE HALF SUN AND THE ROOF SUPPORT BOARDS AND FASTEN WITH TWO 1-1/2" SCREWS.
- 2: EQUALLY SPACE THE SMALL RAYS ABOUT THE HALF SUN (THREE ON EACH SIDE OF LARGE RAY) AND MARK THE POSITION OF THE SMALL SUNRAYS WITH A PENCIL.
- 3: SECURE THE SMALL SUNRAYS ONE AT A TIME TO THE HALF SUN AND THE ROOF SUPPORT BEAMS AND LINE THEM UP WITH THE MARK DRAWN. FASTEN THE SMALL SUNRAYS WITH TWO 1-1/2" WOOD SCREWS EACH. THE OPPOSITE SIDE OF THE FORT WILL NOT GET A SUNRAY.

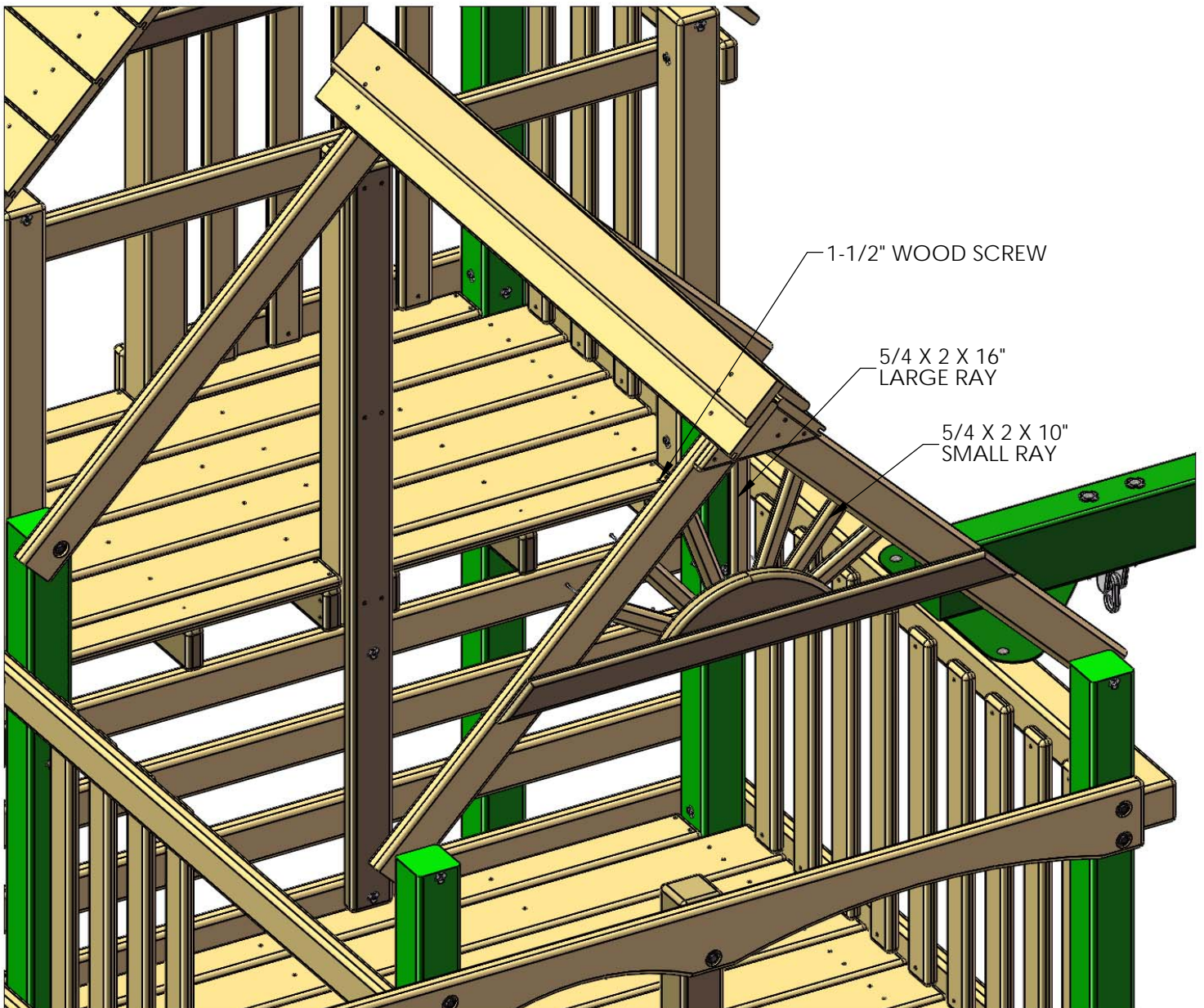

## STEP 68: LOWER LEVEL ROOF

- 1: PLACE THE 1 X 6 X 58" ROOF BOARDS ON TOP OF THE ROOF SUPPORTS, FITTING THE TONGUE END INTO THE GROOVE END OF THE ROOF STARTERS. EACH SIDE OF THE ROOF GETS SEVEN ROOF BOARDS.
- 2: FASTEN THE ROOF BOARDS TO THE ROOF SUPPORTS WITH 1-1/2" WOOD SCREWS.
- 3: PLACE A 1 X 5 X 58" ROOF FINISHER ON THE ENDS OF THE ROOF ASSEMBLY AND FASTEN WITH 1-1/2" WOOD SCREWS.

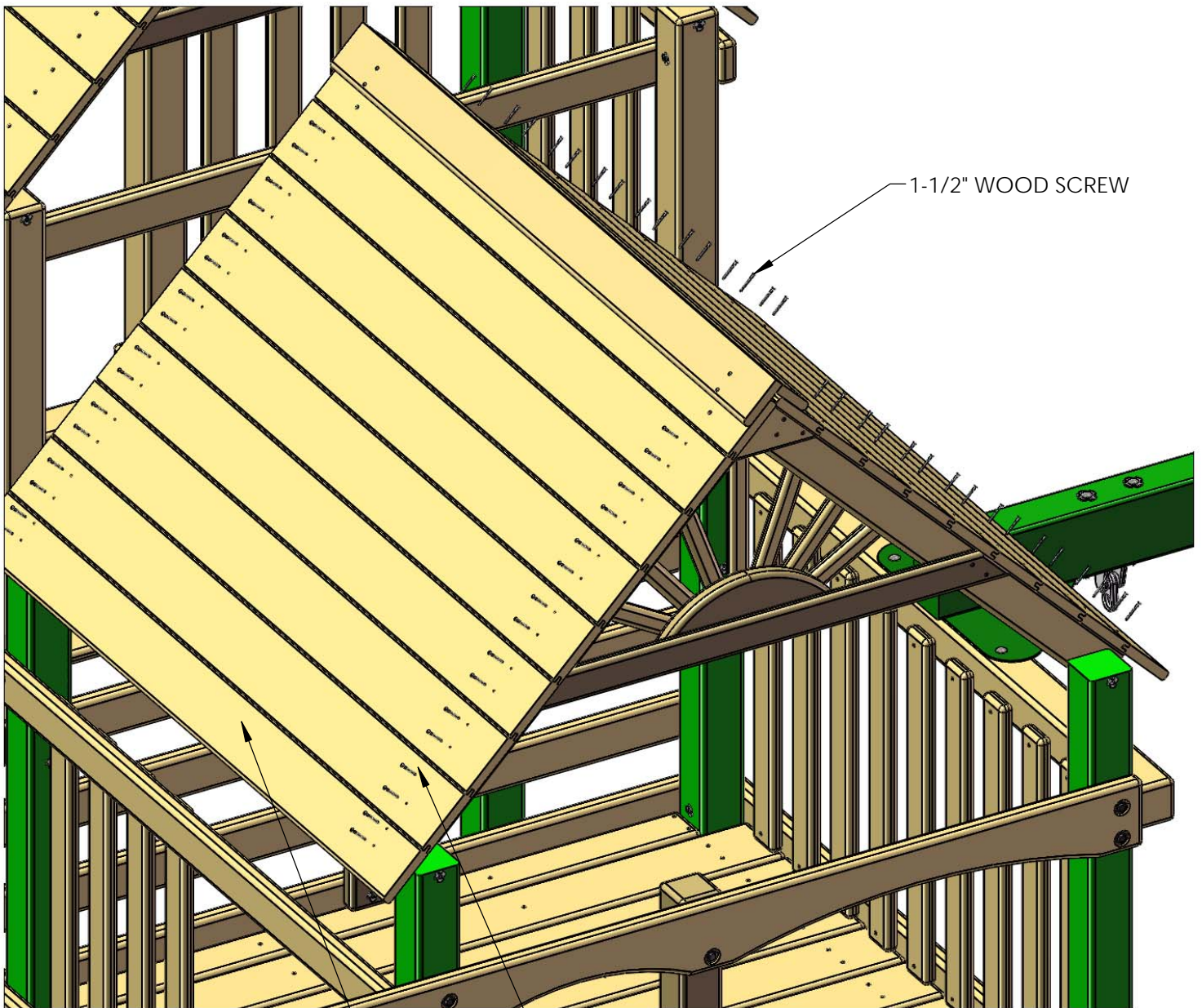

1-1/2" WOOD SCREW

1 X 6 X 58"  
LOWER LEVEL  
ROOF BOARD

1 X 5 X 58"  
LOWER LEVEL  
ROOF FINISHER

## STEP 69: UPPER LEVEL ANGLE SUPPORTS

1: THE TWO 2 X 4 X 21" ANGLE SUPPORTS ARE MOUNTED UNDER THE UPPER LEVEL DECK ON THE LEFT AND RIGHT SIDES OF THE FORT.

2: USE TWO 2-1/2" WOOD SCREWS AT THE TOP OF THE ANGLE SUPPORT TO SECURE IT TO THE DECK SUPPORT. USE ONE 2" AND ONE 3" WOOD SCREW TO SECURE THE ANGLE SUPPORT TO THE CORNER POST.

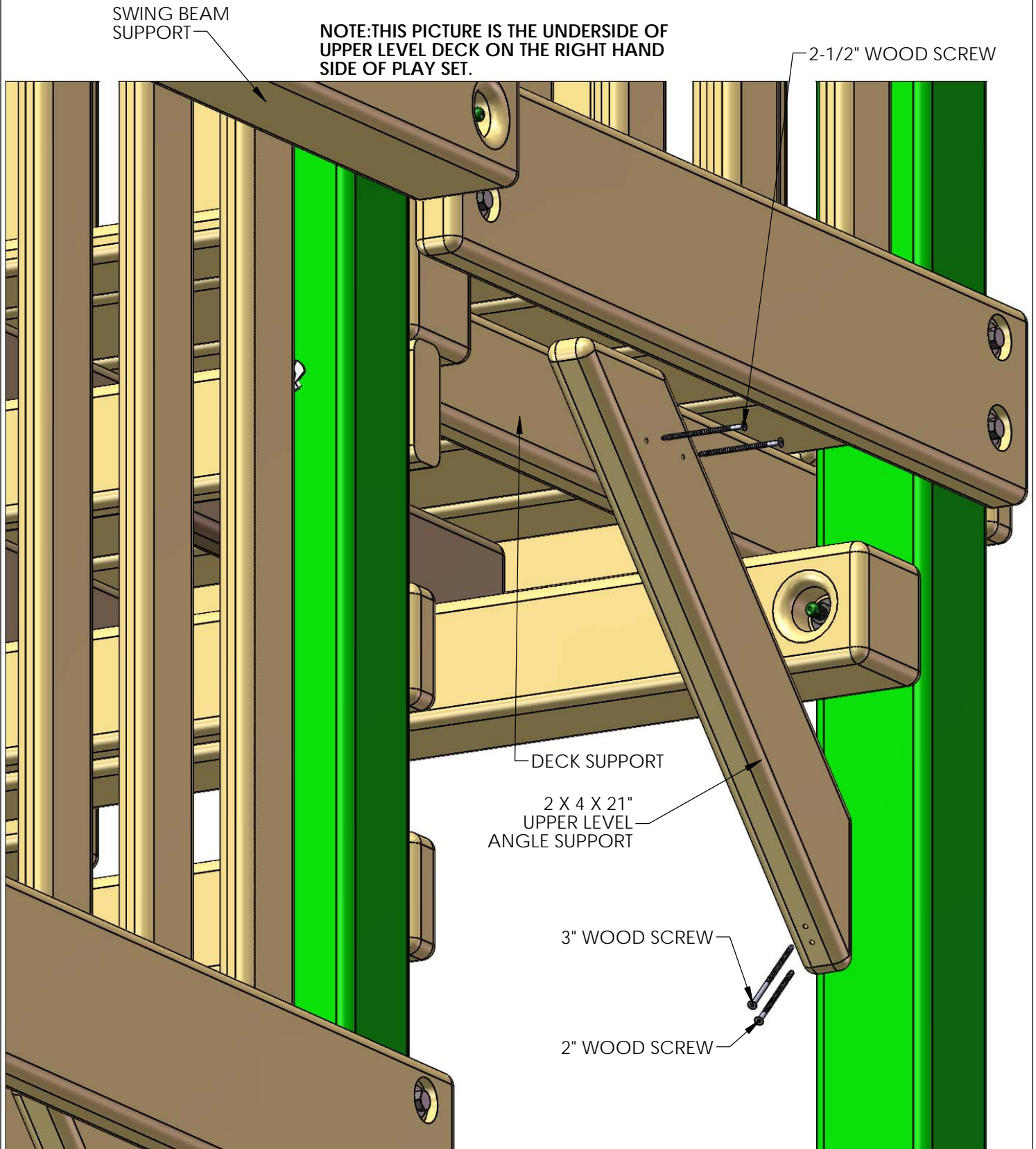



## STEP 70: UPPER LEVEL ANGLE SUPPORTS

- 1: THE 2 X 4 X 15" UPPER LEVEL ANGLE SUPPORTS(TWO) ARE MOUNTED UNDER THE UPPER DECK AT THE BACK OF THE FORT.
- 2: USE TWO 2-1/2" WOOD SCREWS TO ATTACH THE TOP OF THE UPPER LEVEL ANGLE SUPPORT TO THE UPPER LEVEL DECK SUPPORT. USE ONE 2" AND ONE 3" WOOD SCREW TO FASTEN THE UPPER LEVEL ANGLE SUPPORT TO THE CORNER POST.

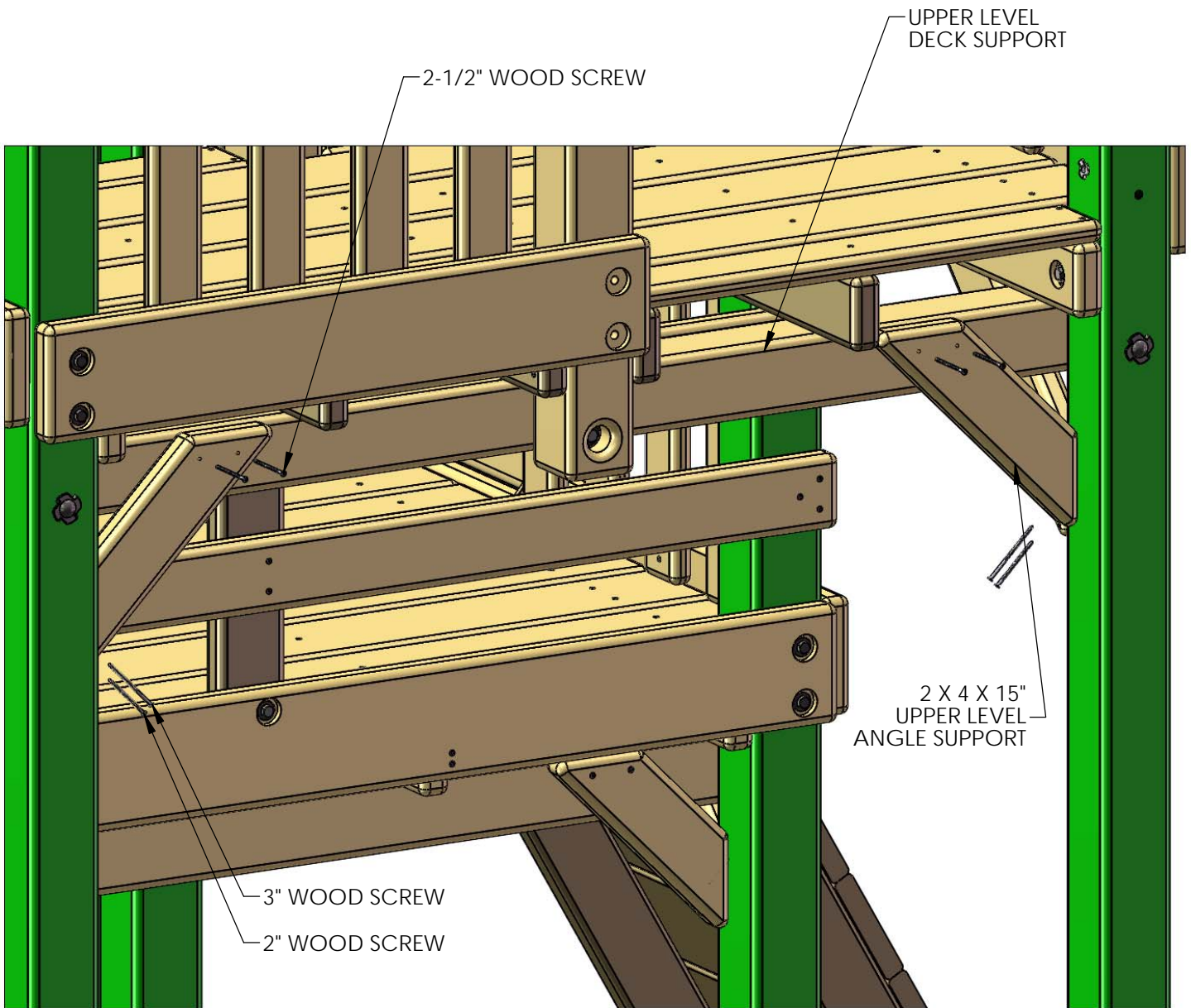

# STEP 71: SAFETY HANDLES

- 1: POSITION THE FIRST SET OF SAFETY HANDLES AT THE FRONT OF THE UNIT, ON THE CORNER POST AND LOWER LEVEL FRONT CENTER POST.
- 2: ADJUST THE SAFETY HANDLES UP OR DOWN TO SUIT THE NEEDS OF YOUR CHILD.
- 3: FASTEN THE SAFETY HANDLES TO THE FORT WITH TWO 1-1/4" PAN HEAD SCREWS AND 1/4" WASHERS PROVIDED WITH THE HANDLES.
- 4: THE UPPER LEVEL SAFETY HANDLES SHOULD BE PLACED ON THE LAG POSTS AND THE UPPER LEVEL FRONT CENTER POST. ADJUST THE HANDLES UP OR DOWN TO SUIT THE NEEDS OF YOUR CHILD. FASTEN HANDLES WITH TWO 1-1/4" PAN HEAD SCREWS AND TWO 1/4" WASHERS.

## INSTALLING LOWER LEVEL SAFETY HANDLES VIEW FROM FRONT OF PLAYSET

PLACE THIS SAFETY HANDLE CLOSE TO THE LEFT SIDE OF THE CENTER POST AS SHOWN TO ALLOW FOR A GAP BETWEEN THE HANDLE AND THE CLATTER BRIDGE RAILING.

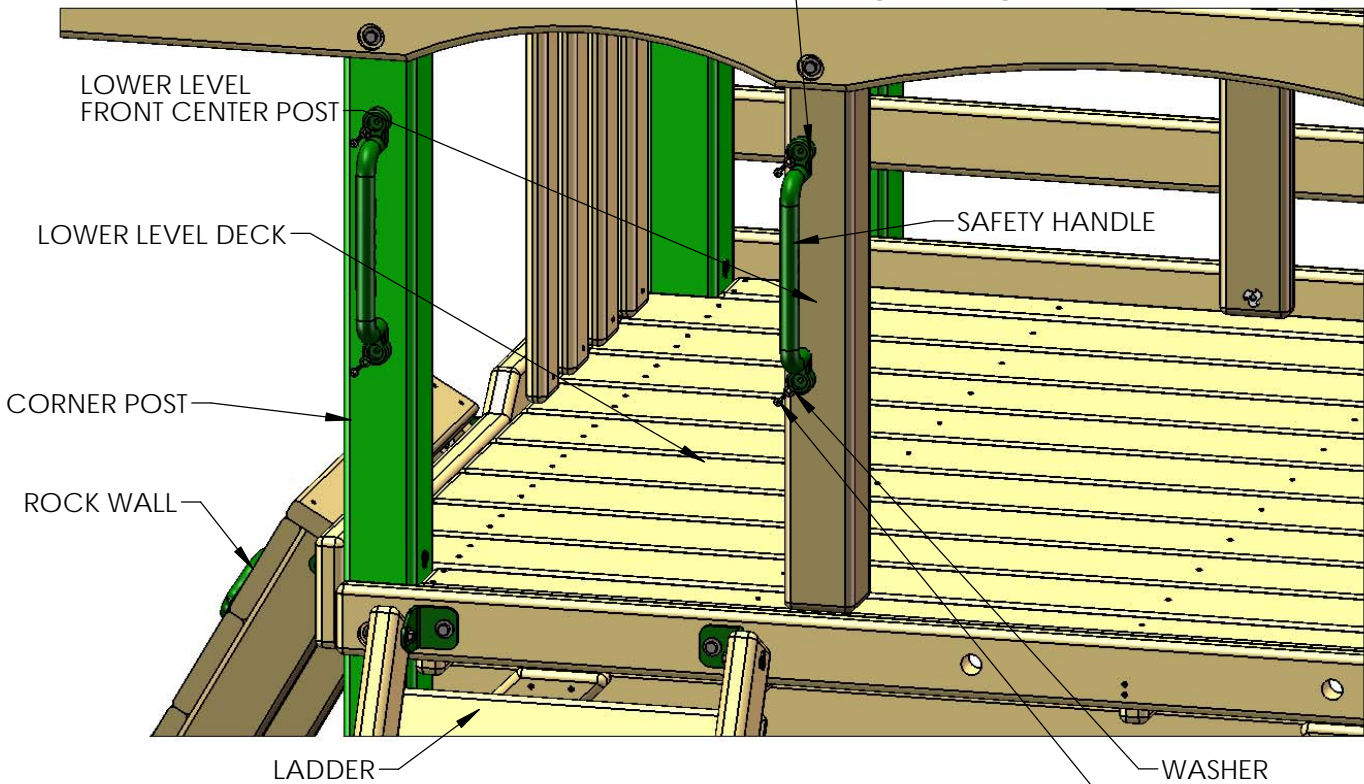

## INSTALLING UPPER LEVEL SAFETY HANDLES VIEW FROM REAR OF PLAYSET

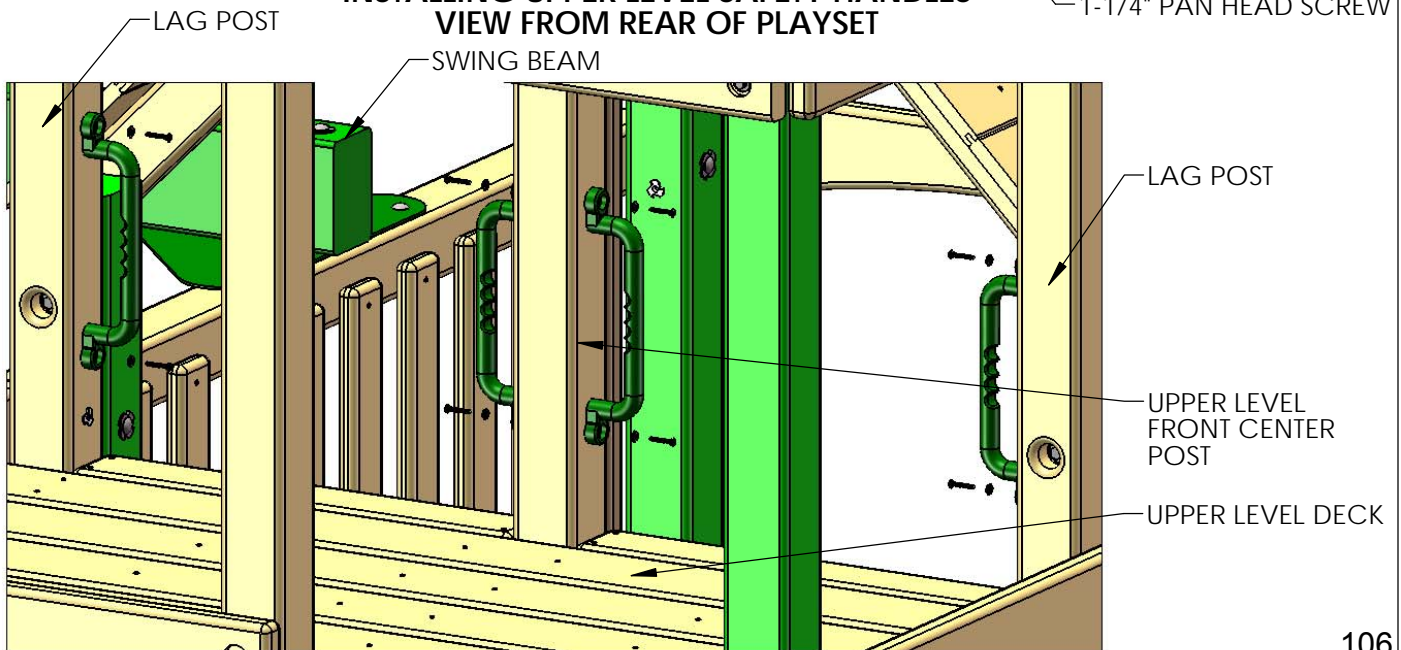

## STEP 72: TELESCOPE

- 1: WITH THE 1-1/4" WOOD SCREWS PROVIDED IN THE TELESCOPE BAG, FASTEN ONE OF THE ROUND TELESCOPE BRACKETS TO THE TOP OF THE UPPER LEVEL REAR CENTER POST.
- 2: PLACE THE TELESCOPE STAND AND TELESCOPE INTO THE SLOT OF THE TELESCOPE BRACKET.
- 3: FASTEN THE REMAINING TELESCOPE BRACKET TO THE OPPOSITE SIDE THAT THE FIRST TELESCOPE BRACKET WAS INSTALLED ON WITH 1-1/4" WOOD SCREWS.

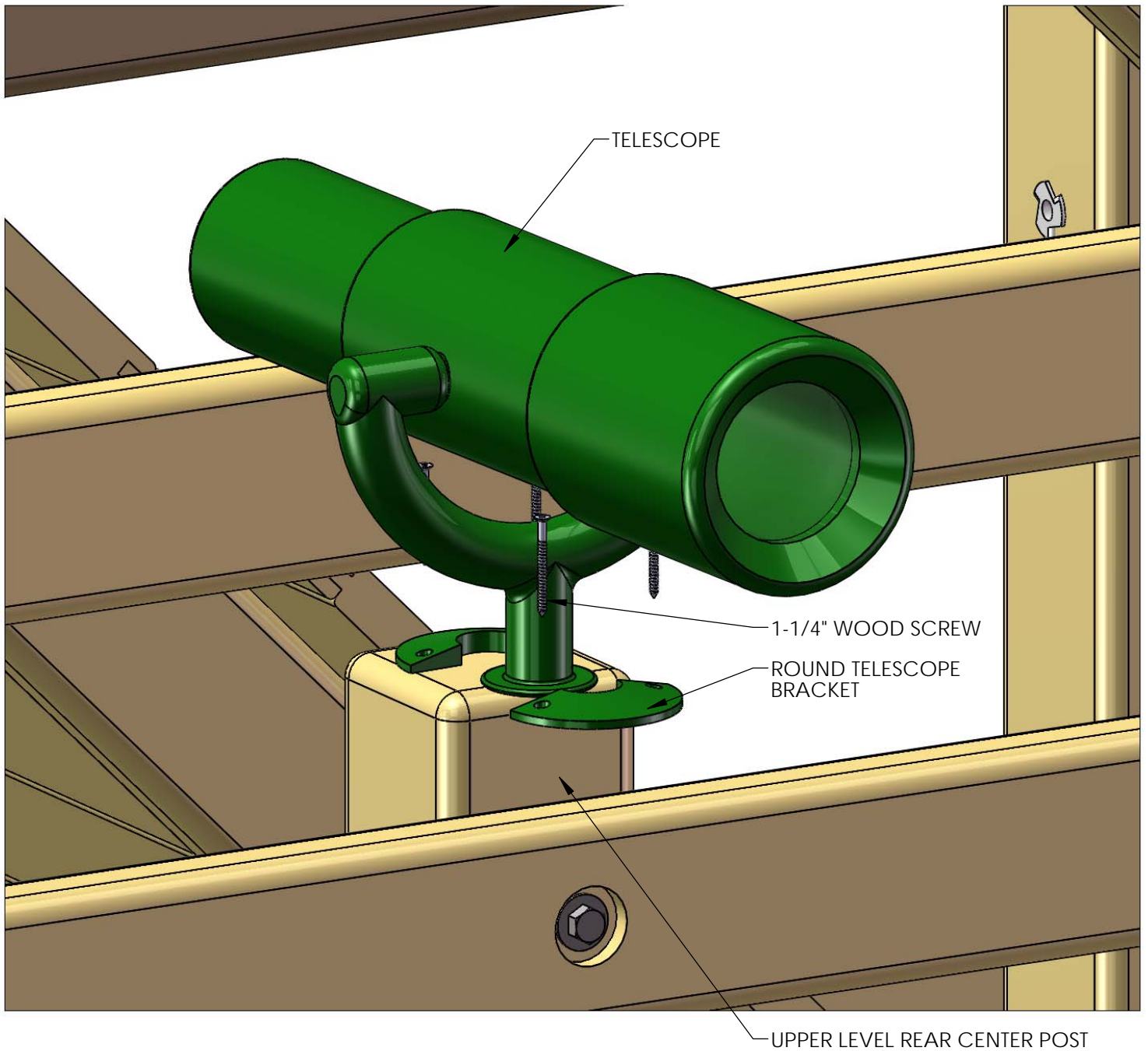

REAR OF FORT (UPPER LEVEL)

## STEP 73: PERISCOPE

- 1: POSITION THE PERISCOPE BRACKET ON THE LOWER LEVEL FRONT CENTER POST, JUST ABOVE THE T-NUT THAT WAS USED TO INSTALL THE POST TO THE ROPE LADDER RUNNER.
- 2: FASTEN THE PERISCOPE BRACKET TO THE LOWER LEVEL FRONT CENTER POST WITH THE PROVIDED HARDWARE.
- 3: THE PERISCOPE WILL SNAP INSIDE THE OPENING OF THE PERISCOPE BRACKET.

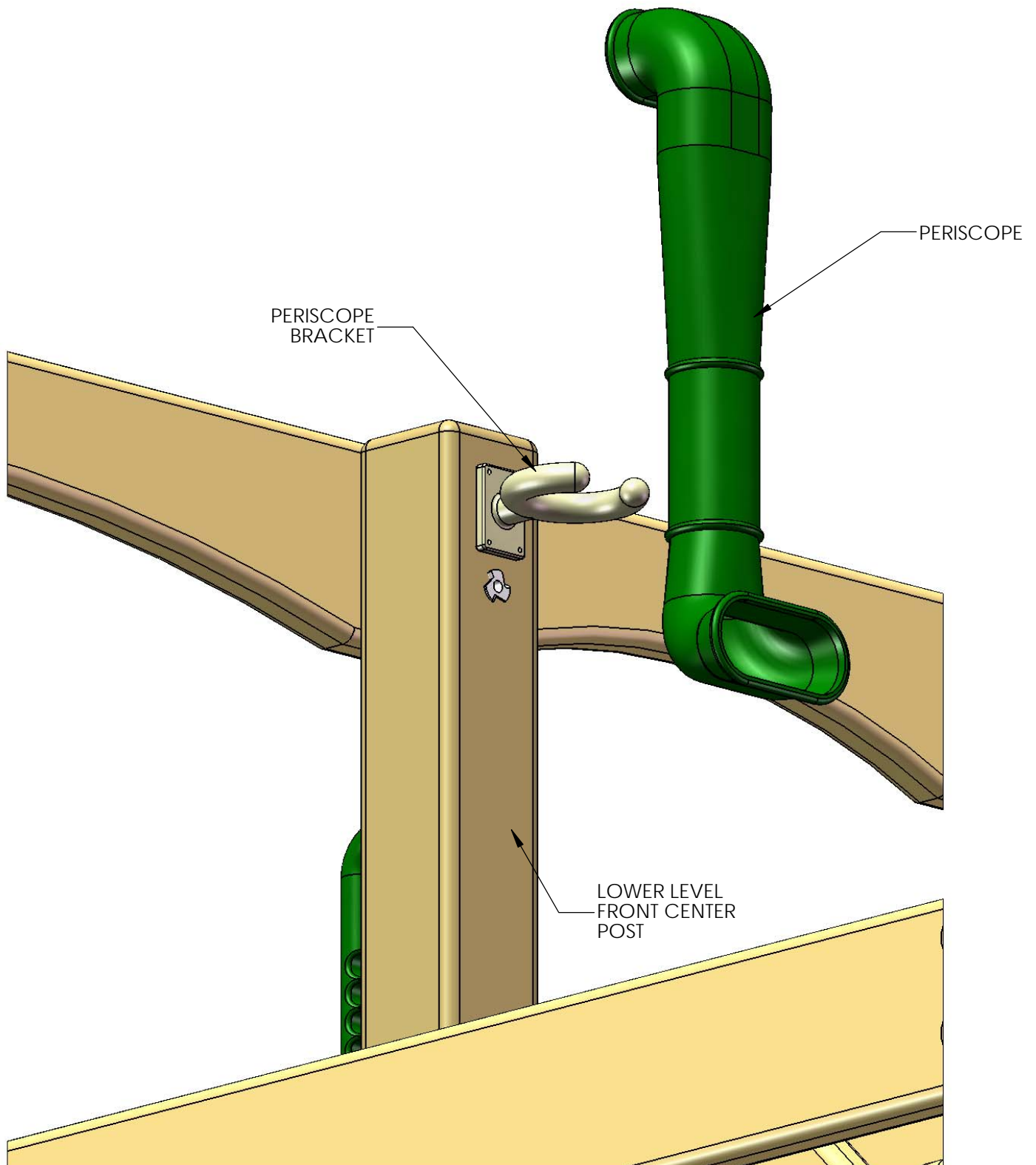

## STEP 74: STEERING WHEEL

- 1: PLACE THE STEERING WHEEL INSERT INSIDE THE STEERING WHEEL.
- 2: USE THE HARDWARE INCLUDED WITH THE STEERING WHEEL TO MOUNT THE STEERING WHEEL TO THE SWING BEAM. DO NOT OVER-TIGHTEN THE LAG SCREW INTO THE STEERING WHEEL, OR IT WILL NOT TURN.
- 3: PLACE THE STEERING WHEEL CAP OVER THE CENTER OF THE STEERING WHEEL.

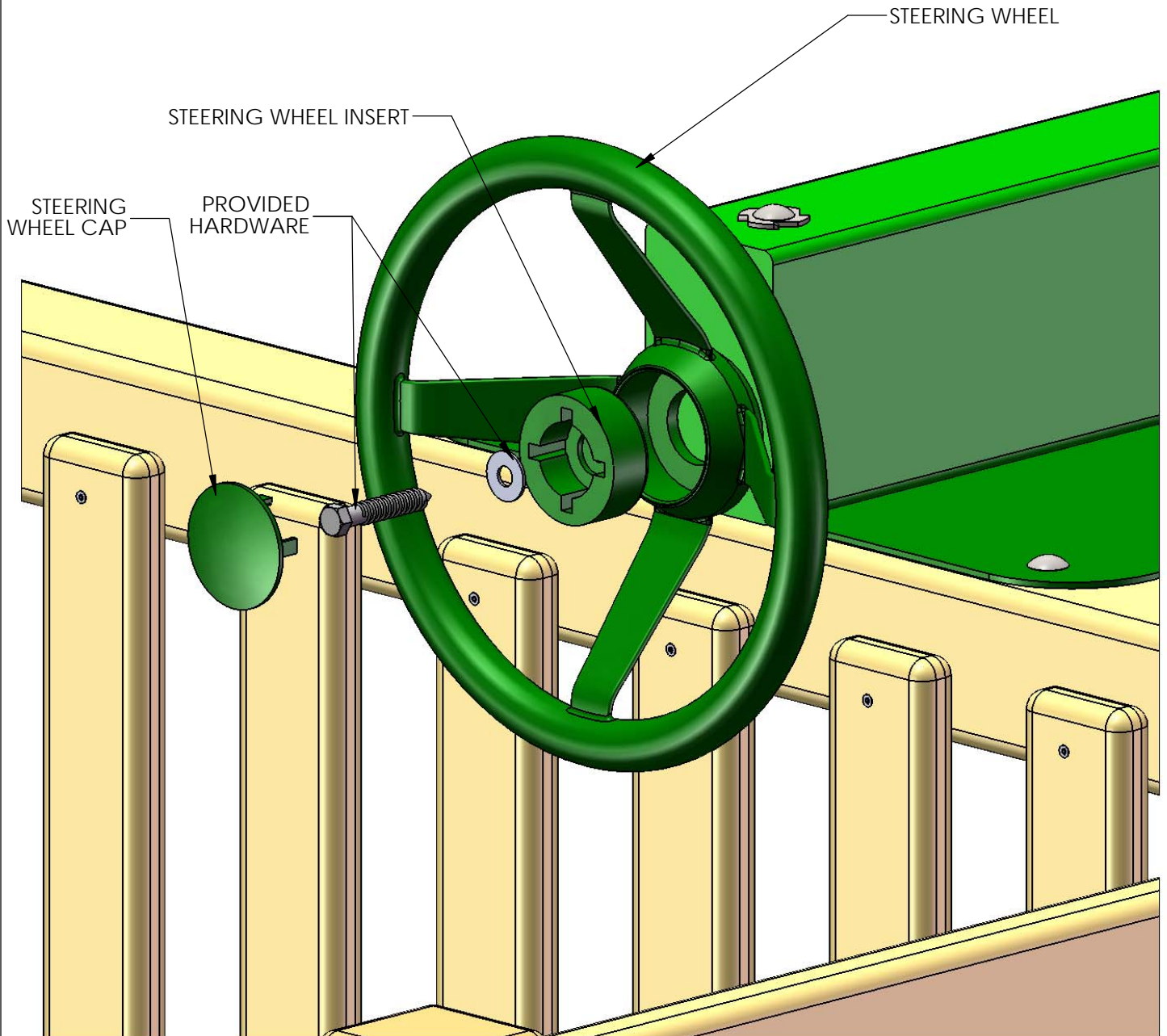

## STEP 75: SANDBOX COVER

\*YOU WILL NEED AN EXTRA PERSON FOR THIS STEP

1: LAY THE SANDBOX COVER ACROSS THE SANDBOX. WITH HELP, PULL EACH SIDE OF THE SANDBOX COVER OVER THE SANDBOX BOARDS, MAKING SURE THAT THE SIDES ARE EVEN.

2: WHEN THE SANDBOX COVER IS AT ITS DESIRED TIGHTNESS, MARK THE LOCATION OF THE BUTTON, AND PLACE THE SNAP IN THAT LOCATION.

3: CONTINUE THIS PROCESS ON EACH OF THE SNAPS, MAKING SURE THAT THE SANDBOX COVER REMAINS TIGHT AND WRINKLE-FREE.

**NOTE: MESH COVER IS NOT WATERPROOF. THE PURPOSE OF THE SANDBOX COVER IS TO KEEP DEBRIS FROM GETTING IN THE SAND (LEAVES, STICKS, ETC.).**

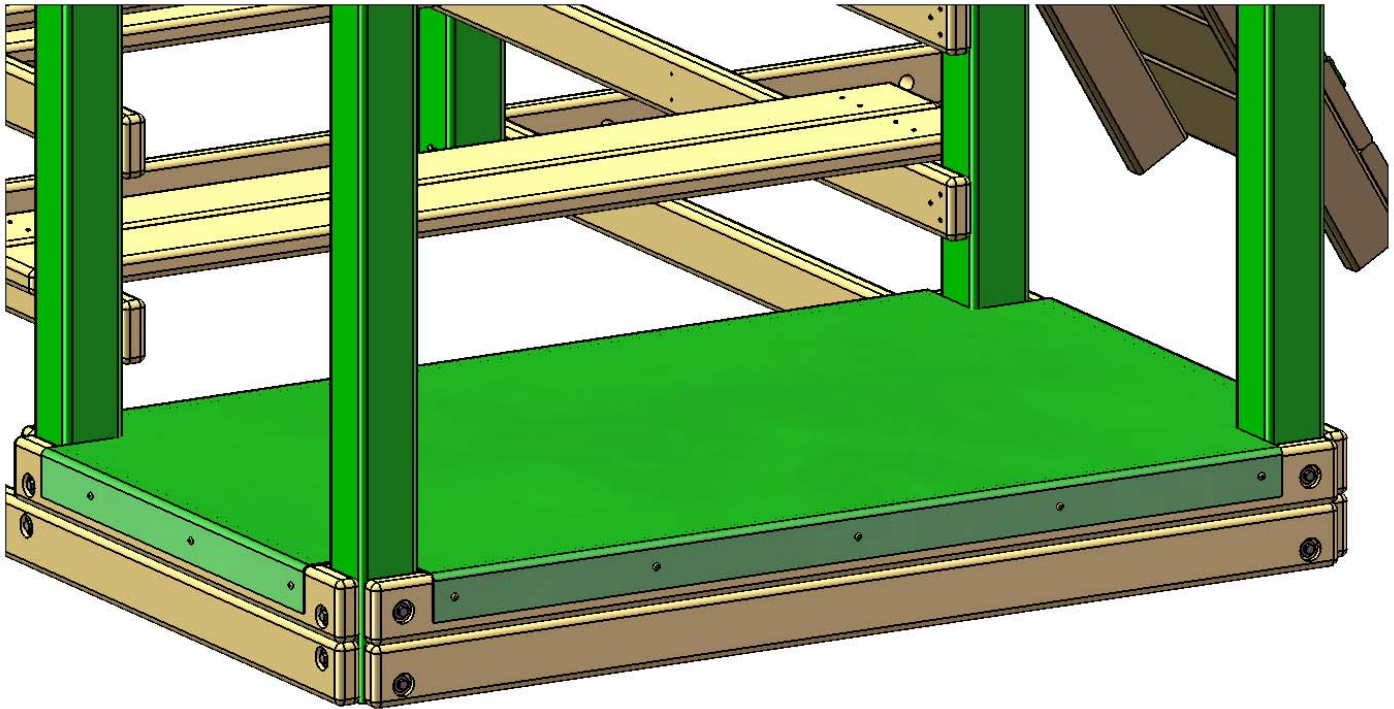

## STEP 76: ROCK WALL ROPE

- 1: THE HOLE MUST BE DRILLED INTO THE TOP PANEL BOARD BEFORE THE ROPE CAN BE ATTACHED. MARK THE LOCATION ON THE TOP PANEL BOARD, CENTERED ABOVE THE ROCK WALL, AND USE A 7/8" DRILL BIT TO DRILL THROUGH THE TOP PANEL BOARD.
- 2: TIE A KNOT ON ONE END OF THE ROPE AND THREAD IT THROUGH THE HOLE DRILLED IN THE TOP PANEL BOARD FROM THE INSIDE OF THE FORT.
- 3: DUE TO THE EXCESS AMOUNT OF ROPE, WE SUGGEST THAT YOU TIE AT LEAST TWO KNOTS IN THE LENGTH OF THE ROPE. THIS WILL AID YOUR CHILD IN CLIMBING AS WELL.
- 4: LIFT THE ROCK WALL ASSEMBLY, AND THREAD THE ROPE THROUGH THE FRONT OF THE BOTTOM ROCK WALL BOARD. MAKE SURE THE ROPE IS TIGHT, AND THEN TIE A KNOT IN THE ROPE BEHIND THE BOTTOM ROCK WALL BOARD. WHEN YOU LOWER THE ROCK WALL, THIS WILL ALLOW THE ROPE TO FULLY TIGHTEN.
- 5: ONCE THE ROPE IS TIED ON BOTH ENDS ATTEMPT TO WRAP THE ROPE AROUND YOUR HAND. IF THE ROPE WRAPS AROUND YOUR HAND IT IS TOO LOOSE. UNTIE ONE END AND RETIE THE ROPE UNTIL YOU CAN NO LONGER WRAP IT AROUND YOUR HAND.

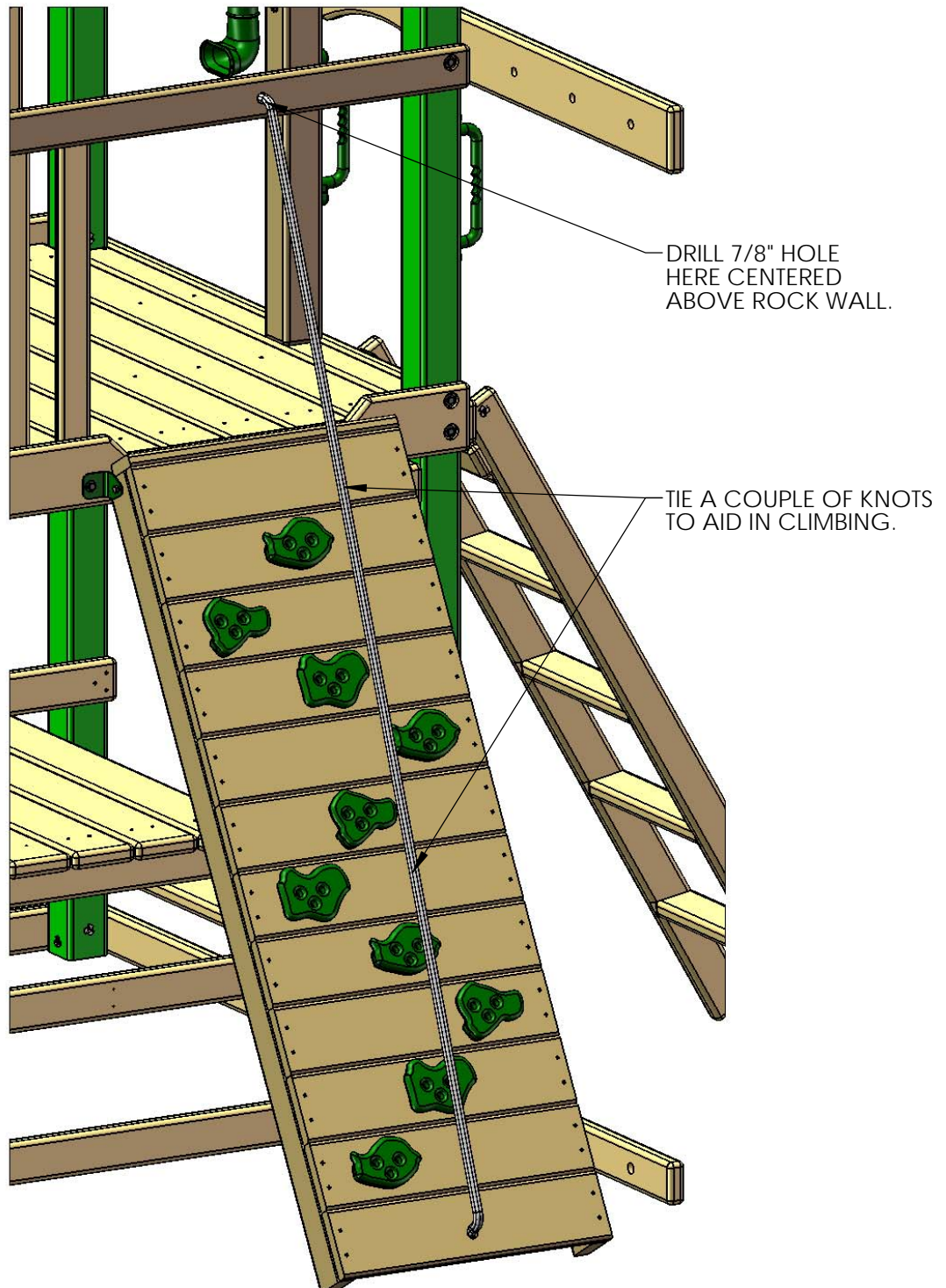

## STEP 77: ROPE LADDER ASSEMBLY

- 1: FIND SIX ROPE LADDER STEPS AND THE THREE 15' LENGTHS OF ROPE. MEASURE 30" FROM ONE SIDE OF EACH PIECE OF ROPE AND MAKE A MARK AT THIS LOCATION.
- 2: TIE A KNOT JUST **ABOVE** THE MARK THAT WAS MADE ON THE ROPE (SEE BELOW).
- 3: THREAD THE ROPE THROUGH THE HOLES OF THE 2 X 4 ROPE LADDER STEP. YOU MAY NEED TO TWIST THE ROPE TO GET IT THROUGH.

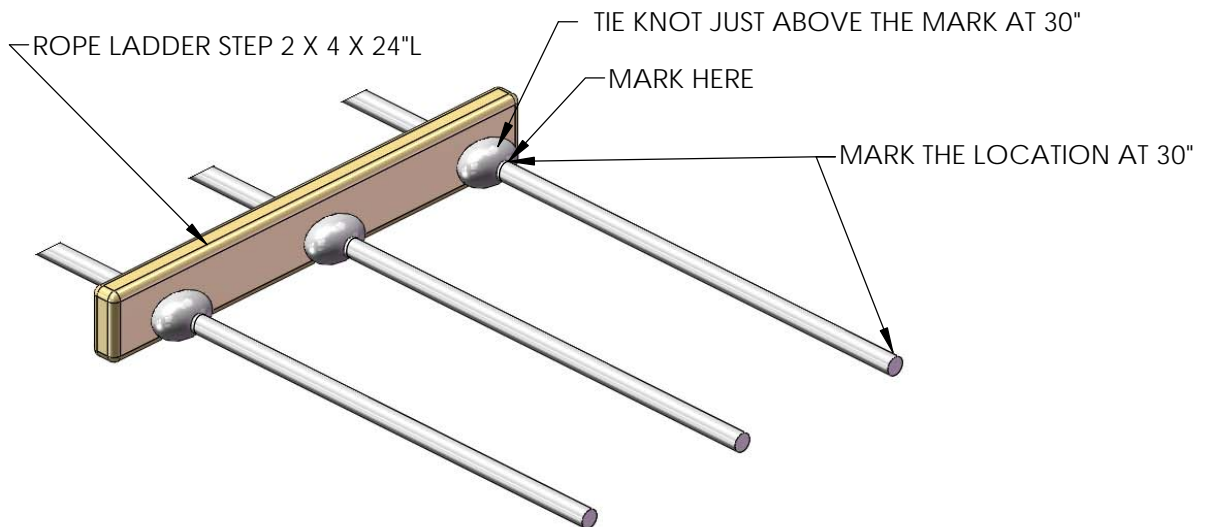

- 4: MAKE SURE THE ROPE LADDER STEP JUST INSTALLED IS RESTING AGAINST THE TIED KNOTS. (NOW SEE FIGURE BELOW) MEASURE 19" FROM THE TOP SIDE OF STEP AND MARK THIS LOCATION ONTO EACH ROPE.
- 5: TIE A KNOT **BELOW** EACH MARK THAT WAS MADE. THREAD EACH ROPE THROUGH THE HOLES IN THE NEXT ROPE LADDER STEP. THERE SHOULD BE APPROXIMATELY A 10" SPACE BETWEEN THE STEPS AFTER THE KNOTS ARE TIED.
- 6: CONTINUE THIS PROCESS UP THE ROPE, AND WHEN THE LAST STEP HAS BEEN PLACED, TIE A KNOT DIRECTLY ABOVE IT. THE LAST STEP TIED WILL BE THE TOP OF THE ROPE LADDER.

AFTER THE LAST STEP IS PLACED ON THE ROPES, TIE A KNOT IN EACH ROPE DIRECTLY ABOVE THE STEP.

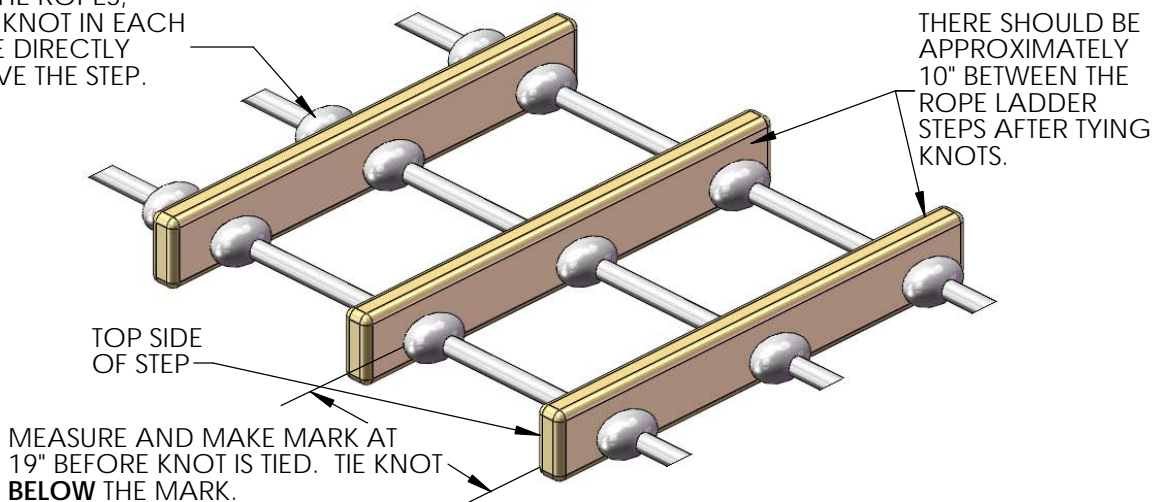



## STEP 78: ROPE LADDER

1: LOOK FOR THE BOARD THAT HAS KNOTS TIED ABOVE AND BELOW THE ROPE LADDER STEP. THIS WILL BE THE TOP OF THE ROPE LADDER.

2: THREAD THE TOP OF THE ROPE LADDER THROUGH THE HOLES IN THE ROPE LADDER SUPPORT, AND TIE A SECURE KNOT.

3: THREAD THE BOTTOM OF THE ROPE LADDER THROUGH THE HOLES IN THE ROPE LADDER RUNNER, AND TIE A SECURE KNOT.

4: ATTEMPT TO WRAP EACH ROPE AROUND YOUR HAND. IF A ROPE WRAPS AROUND YOUR HAND IT IS TOO LOOSE. UNTIE THE BOTTOM END AND RETIRE THE ROPE UNTIL YOU CAN NO LONGER WRAP IT AROUND YOUR HAND.

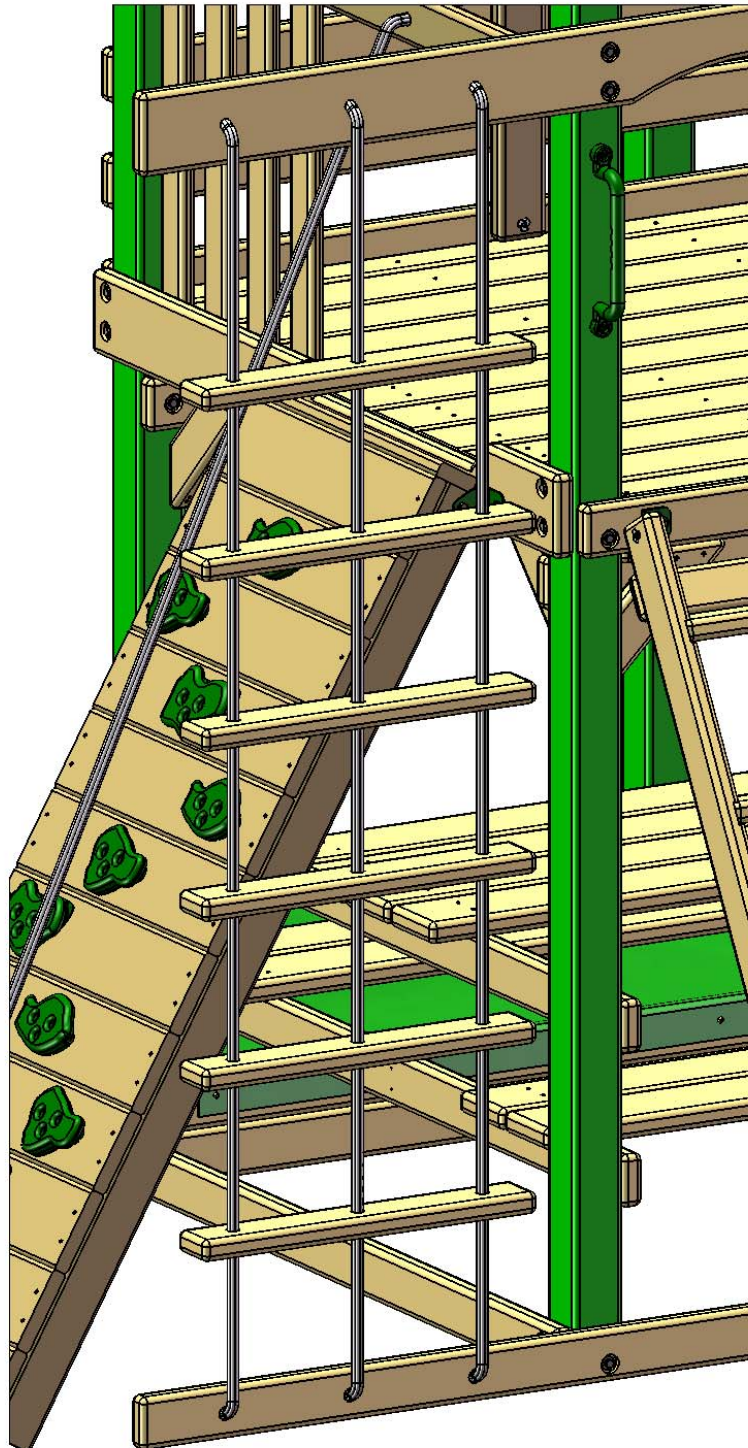

## STEP 79: TIC TAC TOE PANEL

- 1: ASSEMBLE THE TIC-TAC-TOE PANEL ACCORDING TO THE INSTRUCTIONS IN THE BOX. **IGNORE** STEP 6 & STEP 7 IN THE INSTRUCTIONS.
- 2: ATTACH THE TWO 1-3/8" X 1-5/8" X 10-1/2"L TIC-TAC-TOE BOARDS TO THE GREEN PLASTIC BRACKETS WITH THE 1"L PHILLIPS HEAD SCREWS PROVIDED IN THE TIC-TAC-TOE BOX. **IMPORTANT:** MAKE SURE THE TIC-TAC-TOE BOARD IS MOUNTED TO THE GREEN BRACKET OBSERVING THE 1-5/8" DIMENSION SHOWN BELOW.
- 3: CENTER THE UNIT ON THE PANEL SLATS ON THE ROCK WALL SIDE OF THE FORT.
- 4: MOUNT THE LOWER TIC-TAC-TOE BOARD 4" ABOVE THE DECK. ATTACH THE TIC-TAC-TOE BOARDS TO THE PANEL SLATS FROM OUTSIDE THE FORT WITH #8 X 2"L WOOD SCREWS.

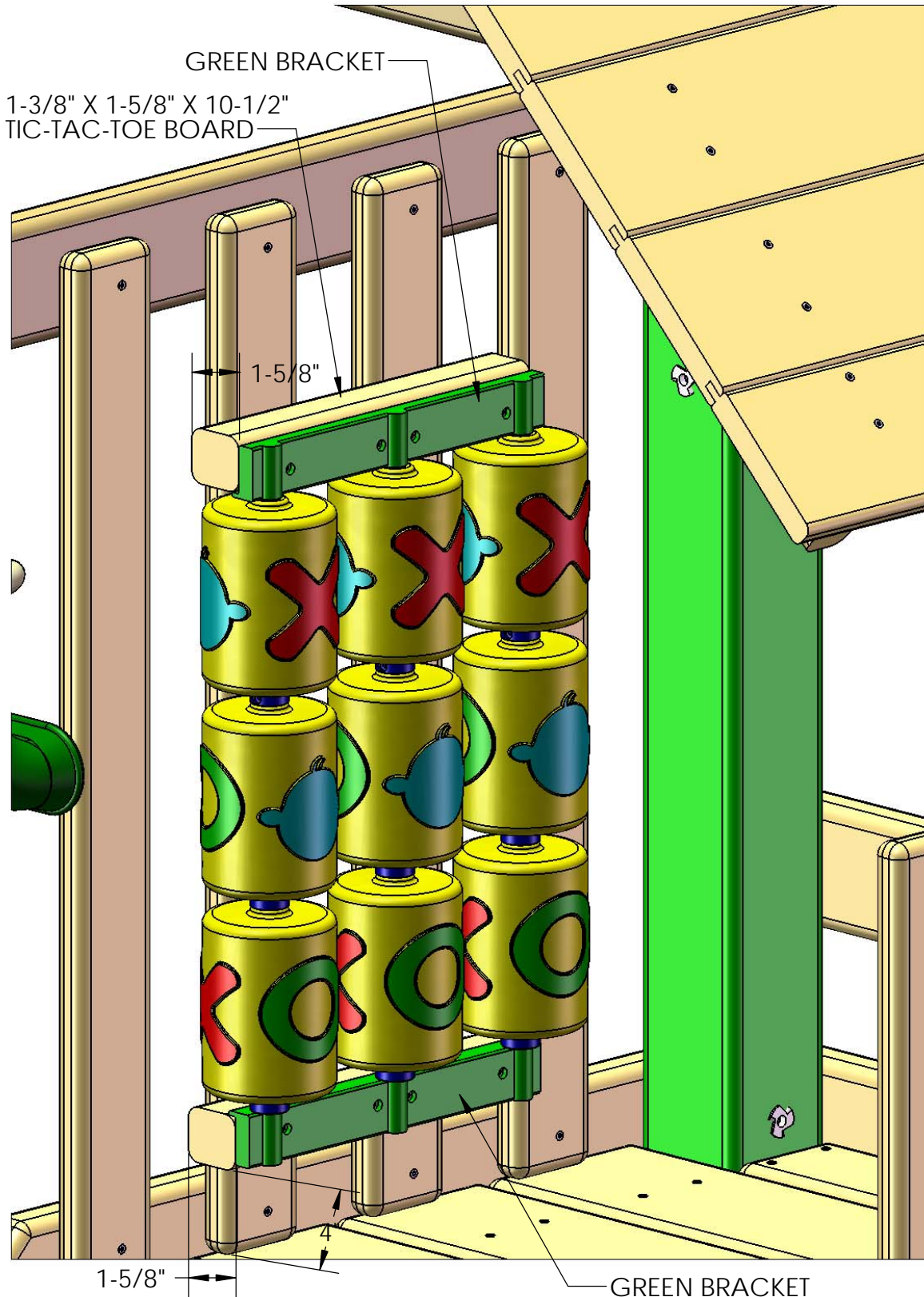

## STEP 80: ATTACHING THE RAD RIDE TO THE FORT

1: ASSEMBLE THE RAD RIDE ACCORDING TO THE INSTRUCTIONS PROVIDED. SEE BELOW FOR PLACEMENT OF YOUR SLIDE.

2: ONCE IN PLACE, TIGHTEN ALL HARDWARE ON THE SLIDE.

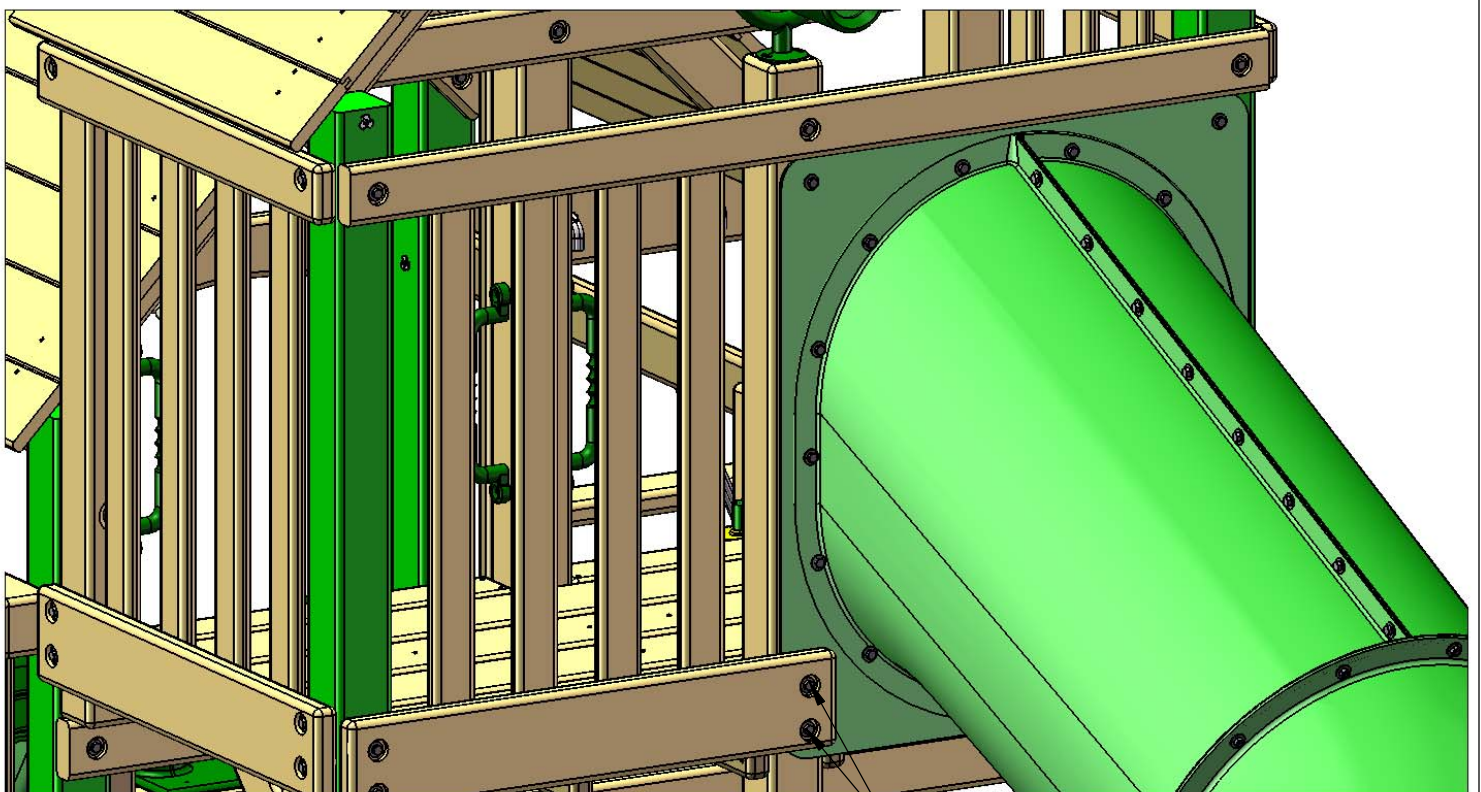
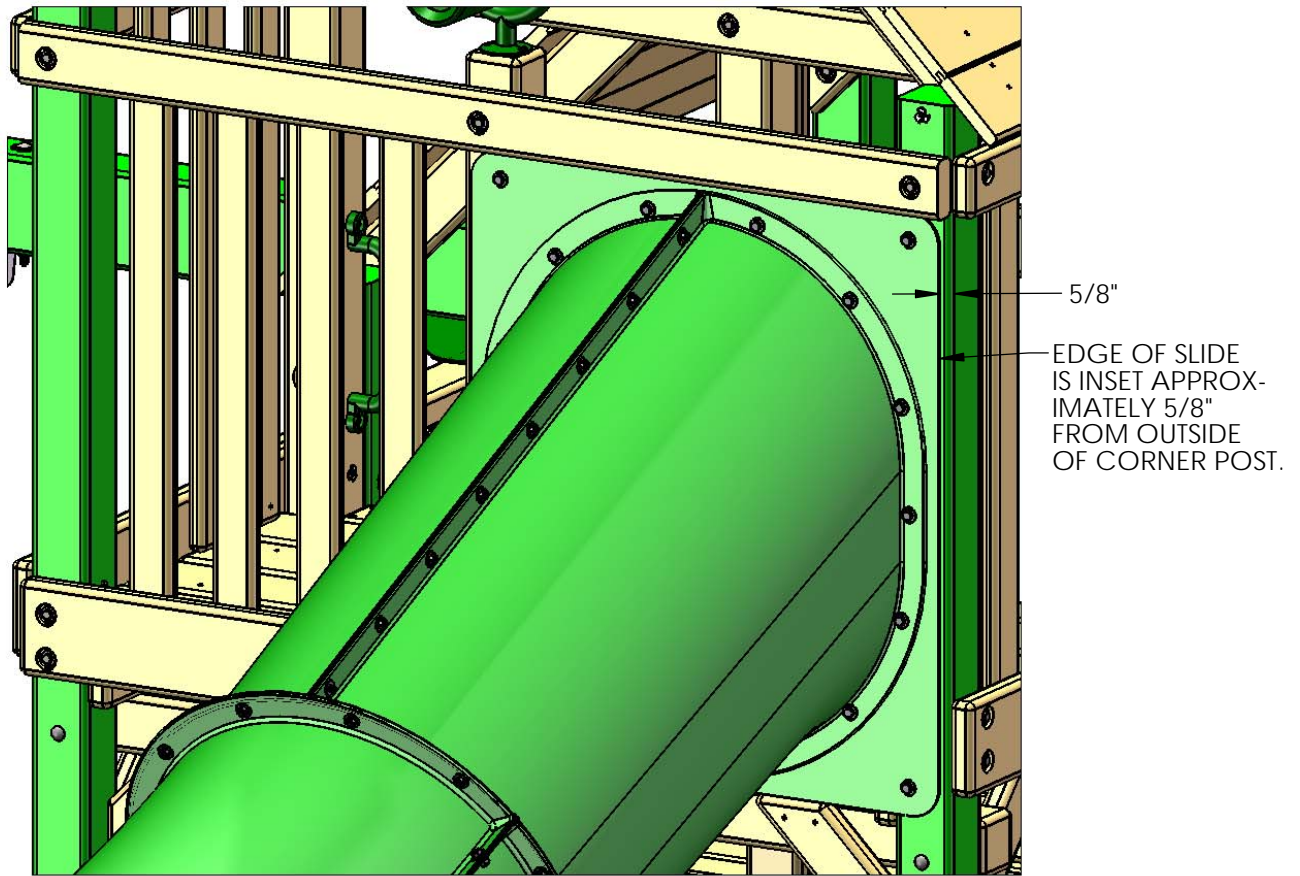

USE 5/16 X 3-1/2" LAG SCREWS AND 5/16" WASHERS IN THESE HOLES

# STEP 81: CHIMNEY AND DORMERS

1: ASSEMBLE AND INSTALL THE CHIMNEY AND DORMERS USING THE INSTRUCTIONS PROVIDED.

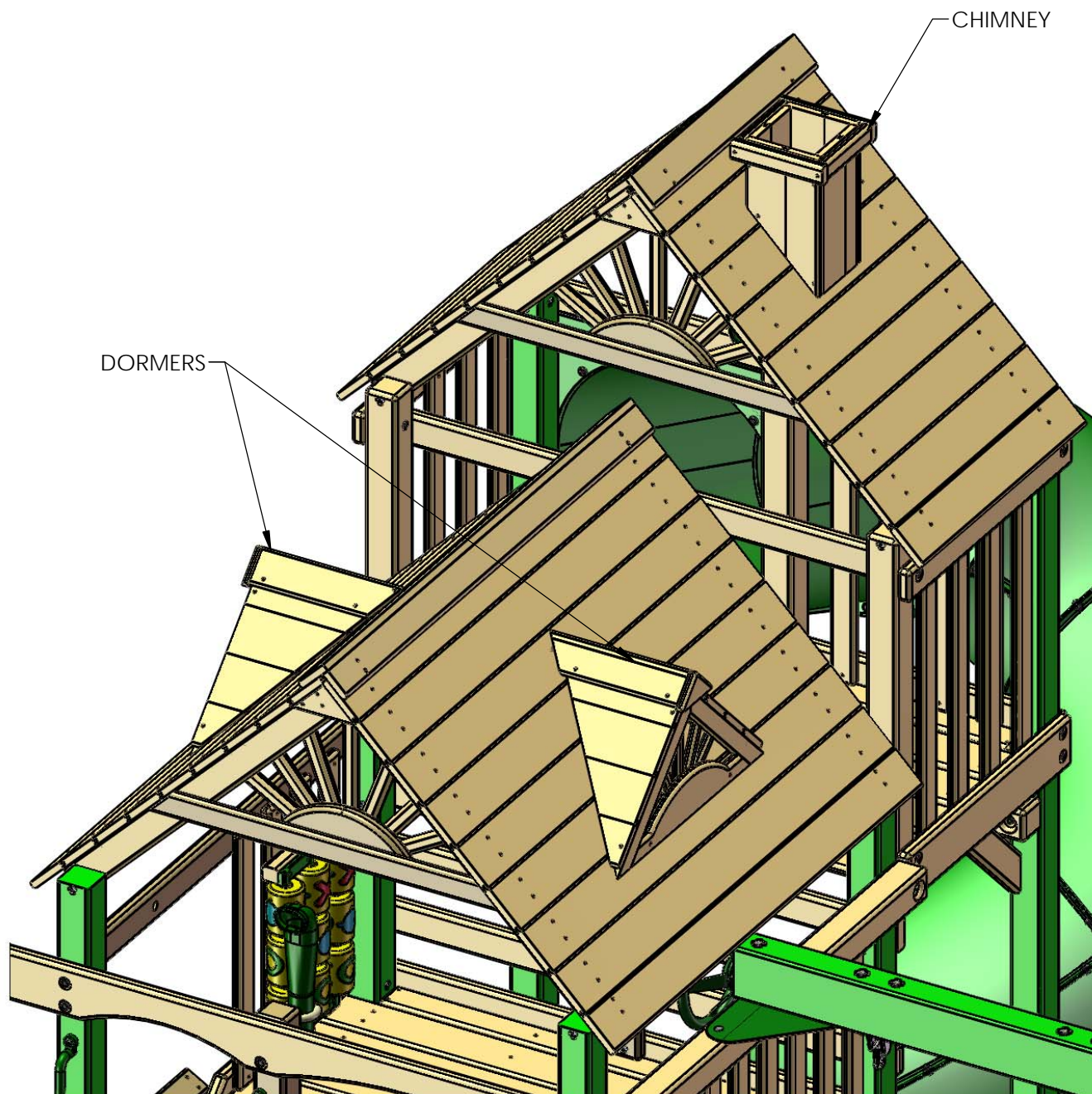

## STEP 82: GLIDER SWING ASSEMBLY

- 1: LINE UP THE HOLES OF THE SEAT WITH BOTH END HANDLE ASSEMBLIES.
- 2: MAKE SURE THAT THE FLAT SIDE OF THE SEAT IS FACING UP.
- 3: INSERT THE PROVIDED BOLTS THROUGH THE HOLES WITH A WASHER AND SECURE IT WITH A WASHER AND NUT.

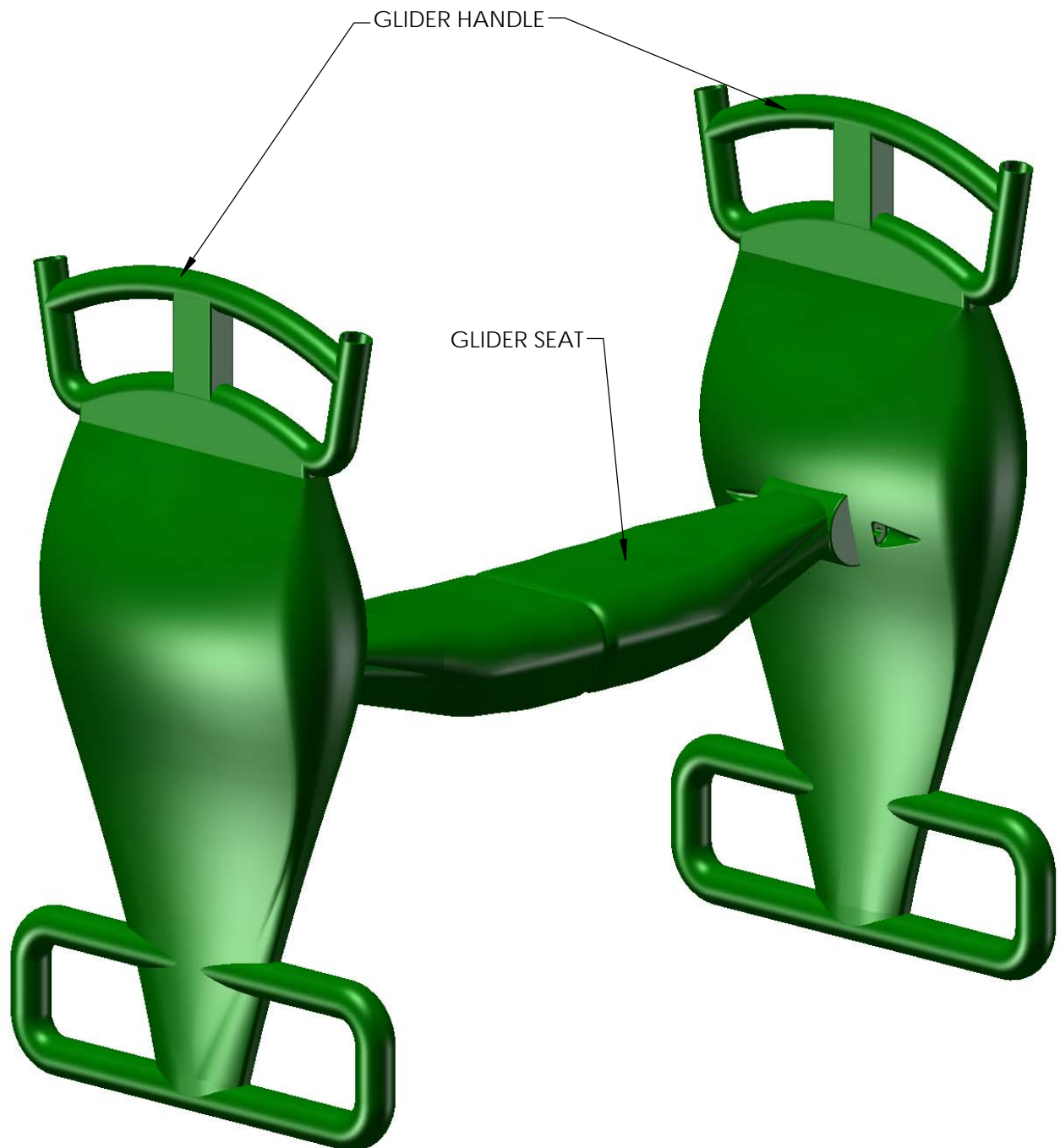

## STEP 83: HANGING THE SWINGS

- 1: START BY ATTACHING ONE SPRING CLIP TO EACH IRON DUCTILE ON THE SWING BEAM.
- 2: ATTACH ONE CHAIN PER ACCESSORY TO EACH SPRING CLIP.
- 3: ADJUST HEIGHT AS NEEDED BY CLIPPING CHAIN TO SPRING CLIP ON HIGHER OR LOWER CHAIN LINKS.

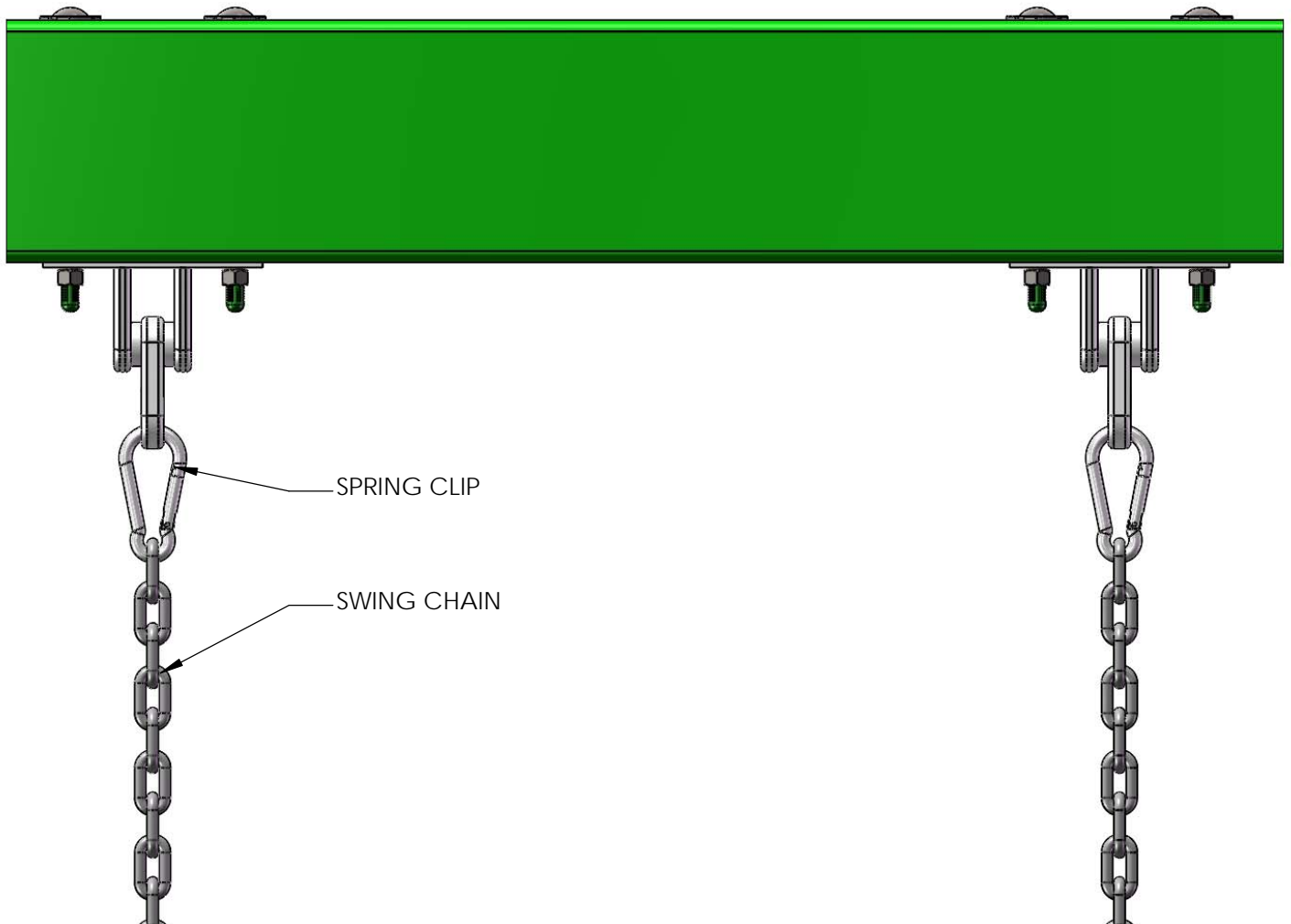

## STEP 84: FLAG KITS

1: PLACE THE FLAG BASES ON THE FRONT CORNER POSTS OF THE FORT AND ATTACH WITH THE HARDWARE PROVIDED WITH THE FLAGS.

2: INSERT THE MAST OF EACH FLAG INTO THE FLAG BASE.

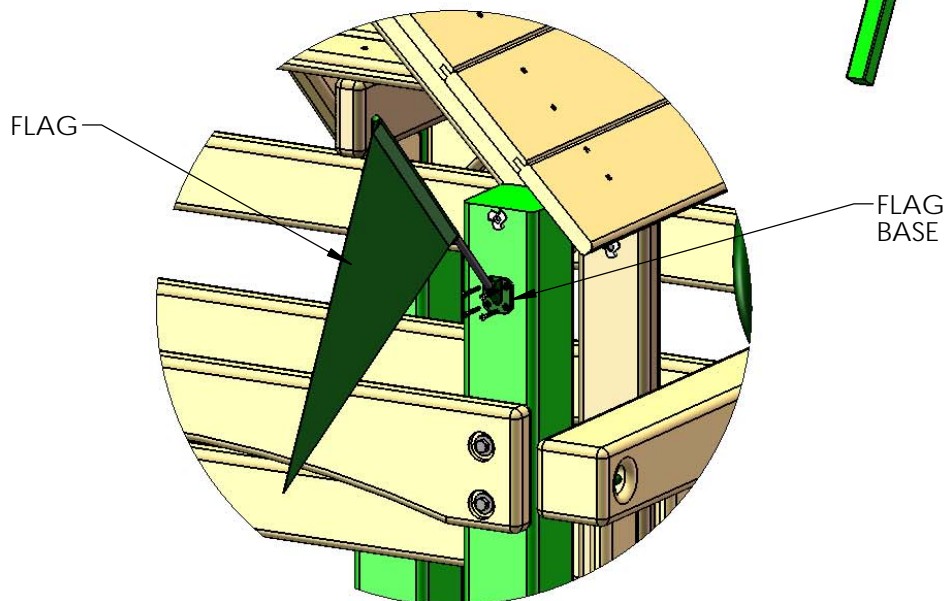
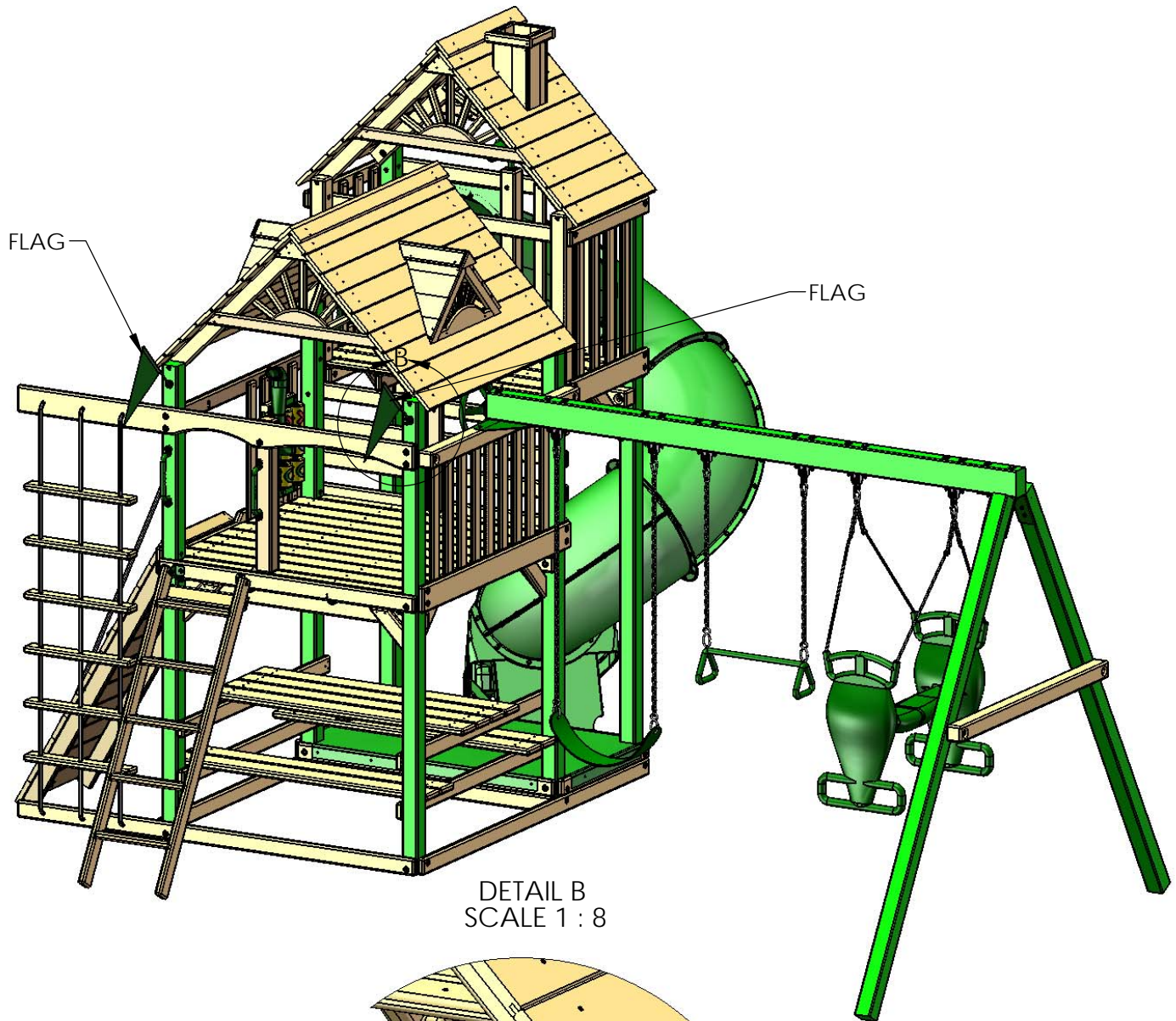

## PART II

# CLATTER BRIDGE WITH TARP FOR PLAY SET



5/16" X 3-1/2"  
HEX LAG  
SCREW  
QTY: 34

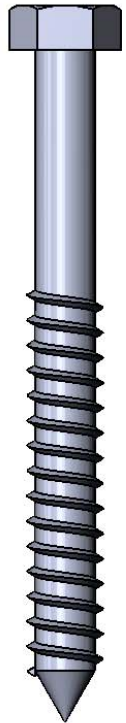

3/8 X 5"  
HEX LAG SCREW  
QTY: 4

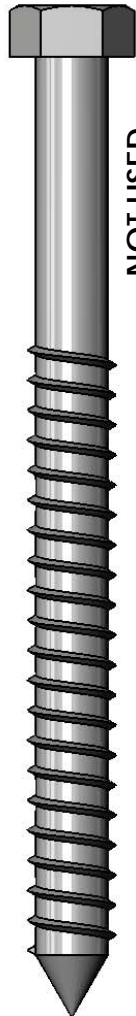

NOT USED

NOTE: THIS SHEET IS A COMBINATION OF  
11-1920 AND 11-0026 HARDWARE.

CHAIN  
QUICK LINK  
QTY: 2

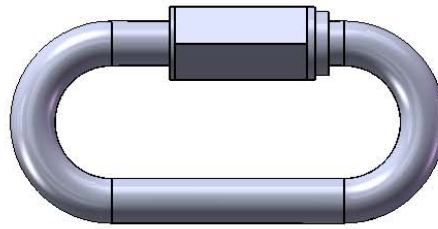

#14 X 1-1/4"  
PAN HEAD SCREW  
QTY: 7



#8 X 2"  
WOOD SCREW  
QTY: 90



#8 X 2-1/2"  
WOOD SCREW  
QTY: 20

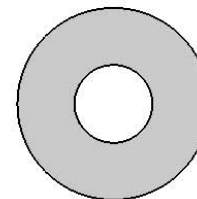

3/8" WASHER  
QTY: 4

NOT USED

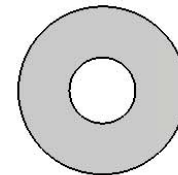

5/16" WASHER  
QTY: 144

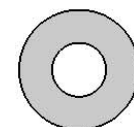

1/4" WASHER  
QTY: 7

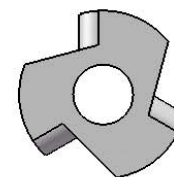

5/16" TEE NUT  
QTY: 56



#2 SQUARE  
DRIVE BIT  
QTY: 1



5/16 X 1-3/4"  
HEX BOLT  
QTY: 30



NOT USED

5/16 X 3-1/2"  
HEX BOLT  
QTY: 4

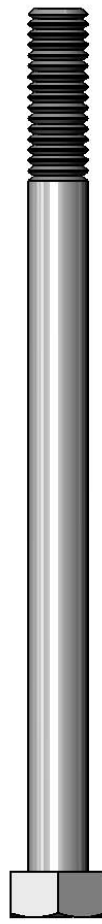

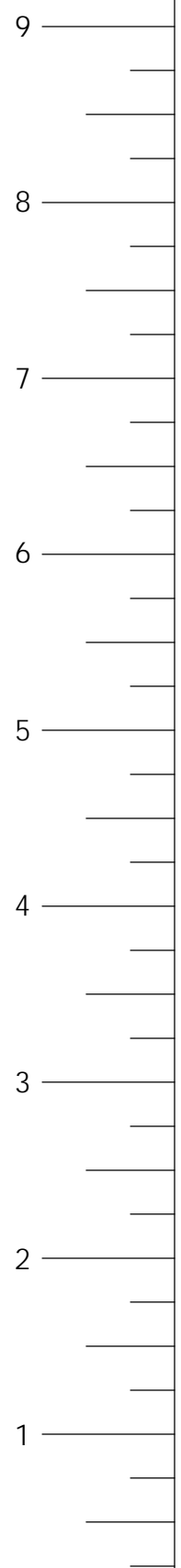

5/16" x 4-1/2"  
HEX BOLT  
QTY: 24

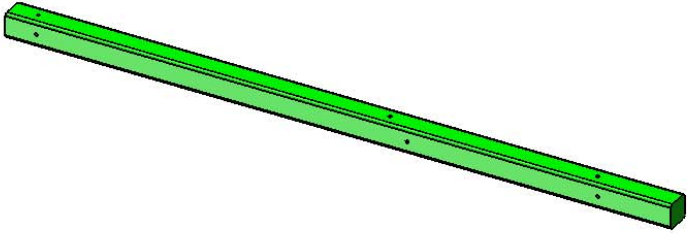
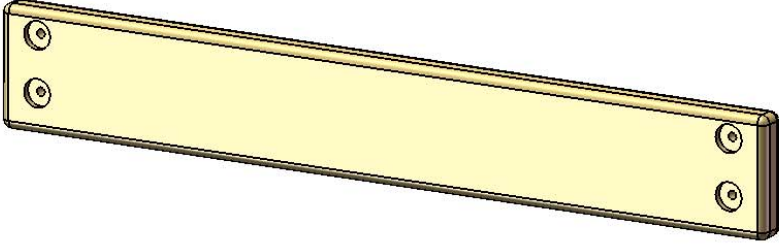
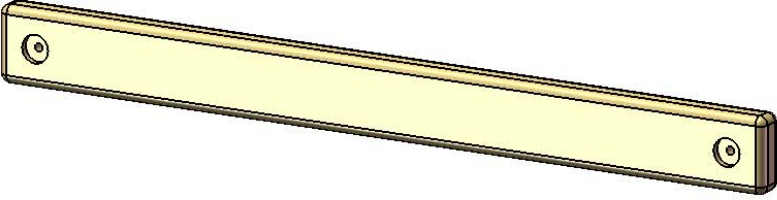
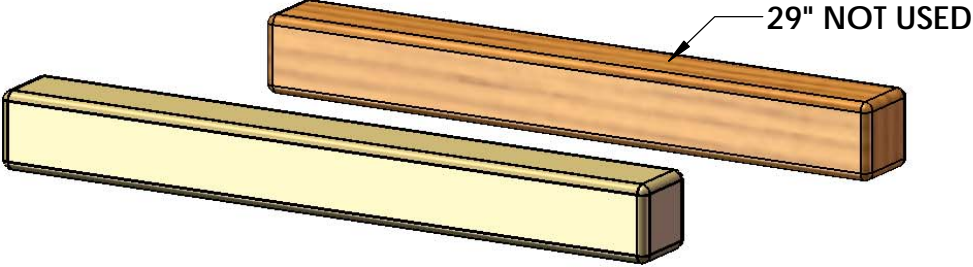
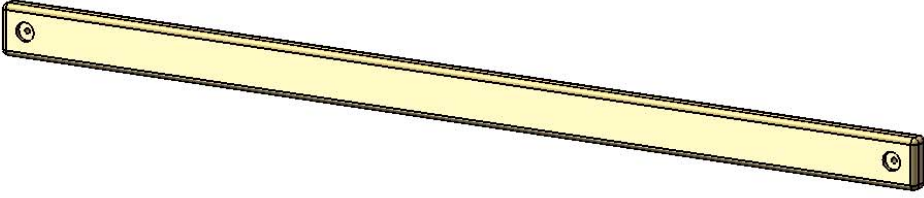
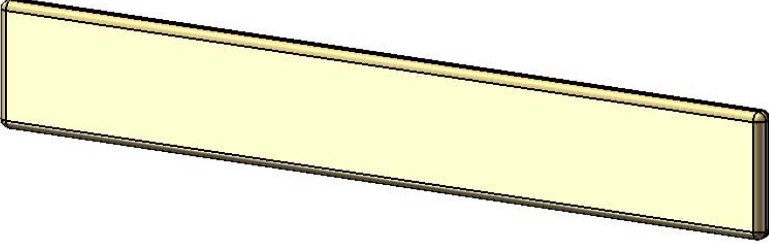
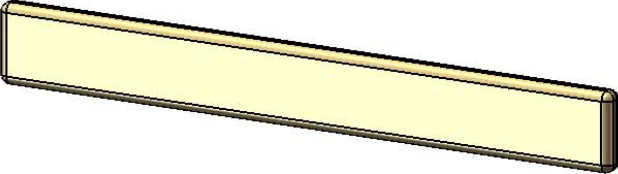

USE THE RULER TO THE RIGHT TO MEASURE YOUR BOLTS AND SCREWS. PICTURE VIEWS SHOWN  
ABOVE ARE 1:1 SCALE AND CAN BE USED TO MATCH BOLT AND SCREW SIZES.

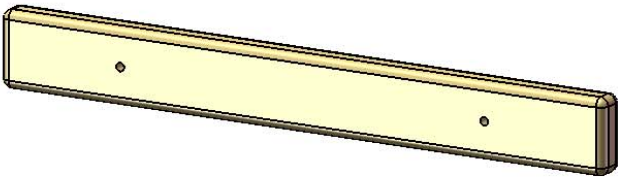
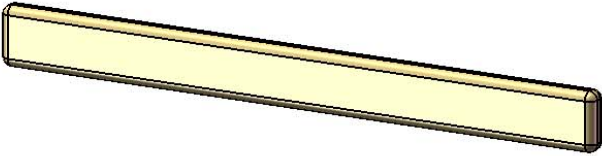
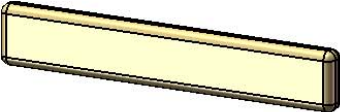
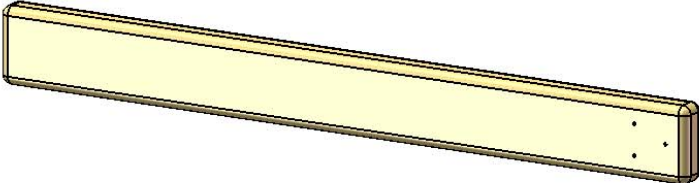
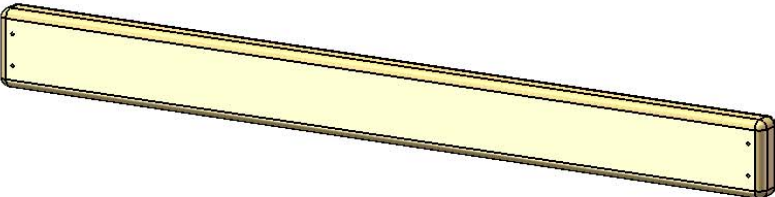
	PICTURE	DESCRIPTION	QTY.
<p>NOTE: THIS LIST IS A COMBINATION OF THE 106 AND 502 WOOD KITS.</p>		<p>4 x 4 x 96" CORNER POST</p>	<p><b>4</b></p>
		<p>2 X 6 X 36-3/4" SANDBOX BOARDS</p>	<p><b>6</b></p>
		<p>2 X 4 X 36-3/4" TOP PANEL/DECK SUPPORT/BOTTOM PANEL BOARD</p>	<p><b>8</b></p>
		<p>4 X 4 X 29" CENTER POST (NOT USED)</p> <p>4 X 4 X 31" CENTER POST</p>	<p><b>1</b></p> <p><b>1</b></p>
		<p>2 X 4 X 66" SAFETY RAIL</p>	<p><b>4</b></p>
		<p>5/4 X 6 X 36-11/16" DECK BOARD</p>	<p><b>5</b></p>
		<p>5/4 X 4 X 29-3/8" DECK SPACER</p>	<p><b>2</b></p>

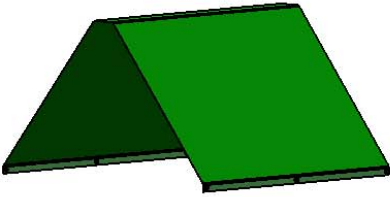
PICTURE	DESCRIPTION	QTY.
	2 X 4 X 29" BRIDGE DECK BOARD	<b>15</b>
	5/4 X 2-5/8" X 28-1/2" PANEL SLAT	<b>10</b>
	5/4 X 2-5/8" X 16" BRIDGE SLAT	<b>20</b>
	2 X 4 X 33" VERTICAL TARP SUPPORT	<b>2</b>
	2 X 4 X 36-3/4" TARP BOARD	<b>3</b>
	96" CHAIN SECTION	<b>2</b>
	802 TARP 57-1/2" X 34-1/4"	<b>1</b>
		<b>123</b>

# STEP 1: ATTACHING T-NUTS TO THE CORNER POSTS

- 1: THIS STEP IS CRITICAL TO BUILDING THE FORT PROPERLY. IF ANY MISTAKES ARE MADE HERE, YOU WILL NEED TO DIS-ASSEMBLE AND THEN RE-ASSEMBLE TO MAKE YOUR CORRECTIONS.
- 2: MAKE SURE HOLES ARE FREE OF ANY OBSTRUCTIONS. USE A BOLT TO CLEAN OUT ANY DEBRIS.
- 3: LAY OUT EACH OF THE 4 X 4 X 96" CORNER POSTS IN THE AREA YOU INTEND ON BUILDING THE TOWER OF THE CLATTER BRIDGE.
- 4: USE THE DIAGRAM BELOW TO CORRECTLY IDENTIFY AND ORIENT THE NECESSARY DIRECTION THE POSTS SHOULD FACE. NOTE LETTERS A, B, C AND D ARE FOR REFERENCE ONLY. YOUR POSTS ARE **NOT** LABELED WITH THESE LETTERS.
- 5: USE A HAMMER TO SEAT THE T-NUTS AFTER INSERTING THEM INTO THE HOLES SHOWN IN THE DIAGRAM BELOW.
- 6: THE BARREL OF THE T-NUT SHOULD GO IN THE HOLE FIRST. HAMMER THE T-NUT UNTIL IT IS FLUSH/ALMOST FLUSH TO THE CORNER POSTS.

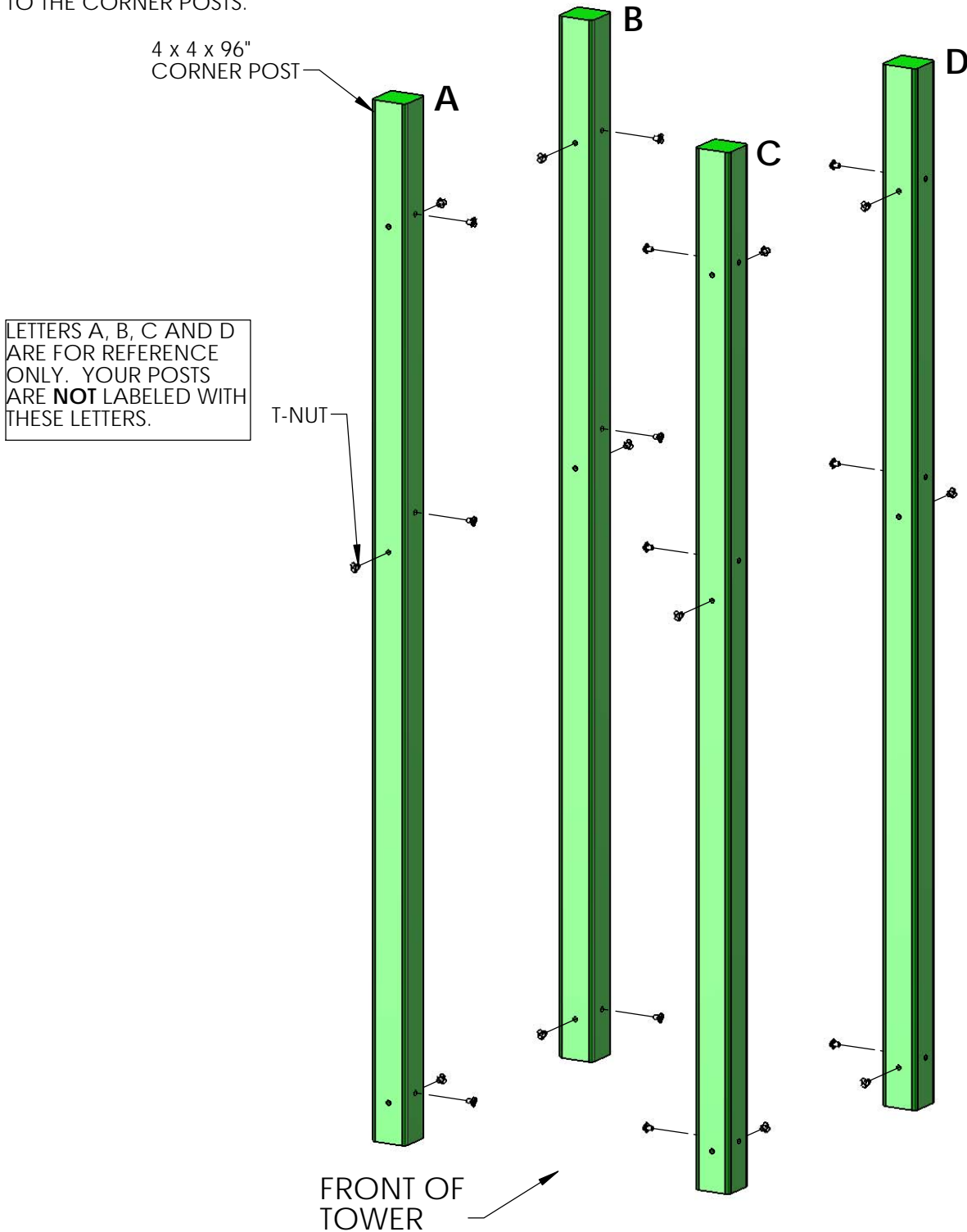

## STEP 2: ASSEMBLING THE RIGHT SIDE FRAME

- 1: LAY THE 2 X 6 X 36-3/4" SANDBOX BOARD ON TOP OF THE RIGHT SIDE CORNER POSTS AT THE BOTTOM OF THE CORNER POSTS. THE COUNTERSUNK HOLES IN THE SANDBOX BOARD MUST BE OFFSET UP.
- 2: USE 5/16 X 4-1/2" HEX BOLTS AND 5/16" WASHERS TO ATTACH THE TOP HOLES OF THE SANDBOX BOARD TO THE T-NUTS INSTALLED ON THE CORNER POSTS. THE BOTTOM HOLES WILL BE USED LATER.
- 3: LAY THE 2 X 6 X 36-3/4" BOTTOM PANEL BOARD ON TOP OF THE RIGHT SIDE CORNER POSTS IN THE MIDDLE OF THE CORNER POSTS. THE COUNTERSUNK HOLES IN THE BOTTOM PANEL BOARD MUST BE OFFSET UP.
- 4: USE 5/16 X 4-1/2" HEX BOLTS AND 5/16" WASHERS TO ATTACH THE TOP HOLES OF THE BOTTOM PANEL BOARD TO THE T-NUTS INSTALLED ON THE CORNER POSTS. THE BOTTOM HOLES WILL BE USED LATER.
- 5: LAY THE 2 X 4 X 36-3/4" TOP PANEL BOARD ON TOP OF THE RIGHT SIDE CORNER POSTS.
- 6: USE 5/16 X 4-1/2" HEX BOLTS AND 5/16" WASHERS TO ATTACH THE COUNTERSUNK HOLES OF THE TOP PANEL BOARD TO THE T-NUTS INSTALLED ON THE CORNER POSTS.
- 7: DO NOT INSTALL LAG SCREWS AT THIS TIME.

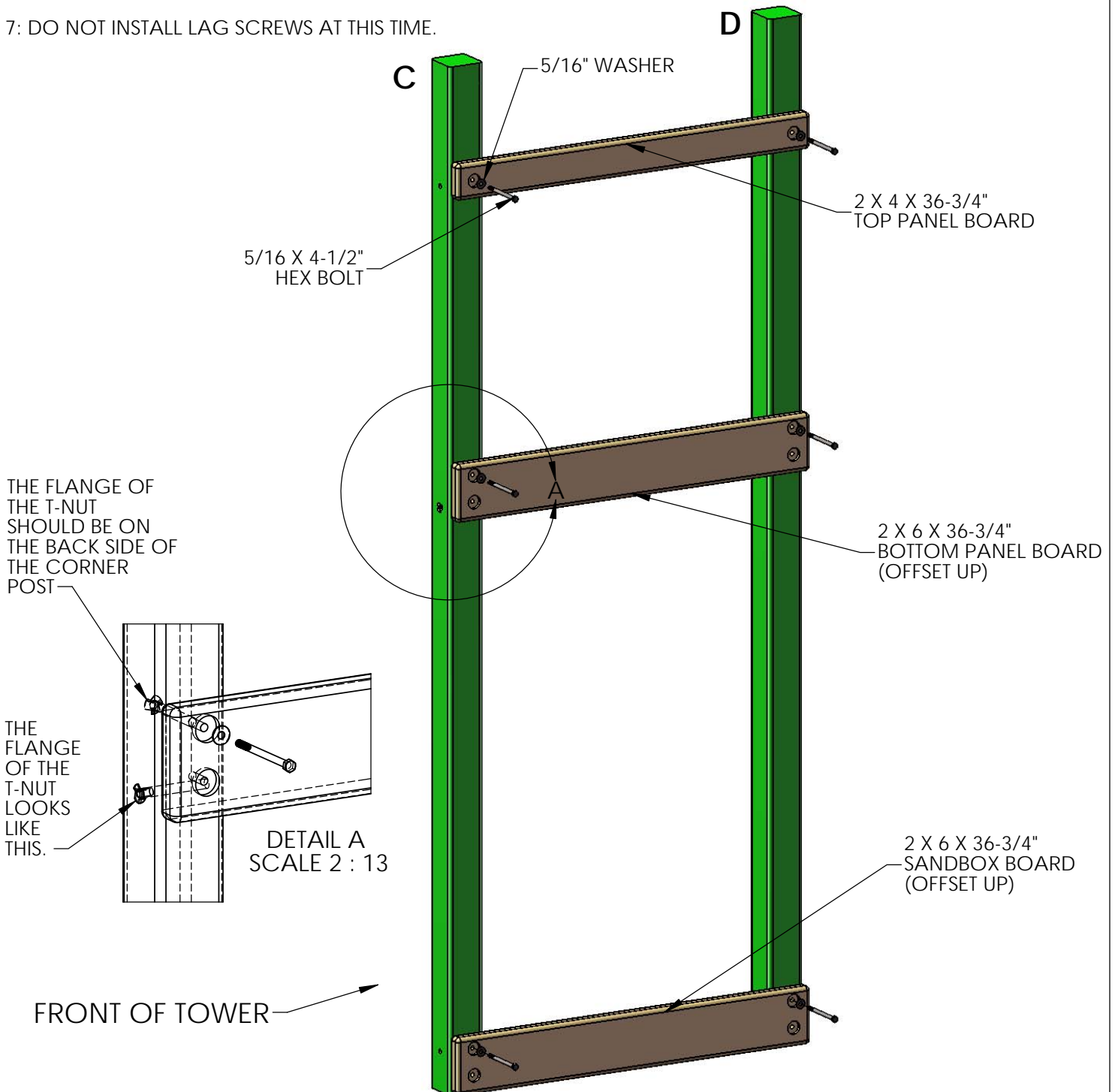

## STEP 3: ASSEMBLING THE LEFT SIDE FRAME

1: LAY THE 2 X 6 X 36-3/4" SANDBOX BOARD ON TOP OF THE LEFT SIDE CORNER POSTS AT THE BOTTOM OF THE CORNER POSTS. THE COUNTERSUNK HOLES IN THE SANDBOX BOARD MUST BE OFFSET UP.

2: USE 5/16 X 4-1/2" HEX BOLTS AND 5/16" WASHERS TO ATTACH THE TOP HOLES OF THE SANDBOX BOARD TO THE T-NUTS INSTALLED ON THE CORNER POSTS. THE BOTTOM HOLES WILL BE USED LATER.

3: LAY THE 2 X 6 X 36-3/4" BOTTOM PANEL BOARD ON TOP OF THE LEFT SIDE CORNER POSTS IN THE MIDDLE OF THE CORNER POSTS. THE COUNTERSUNK HOLES IN THE BOTTOM PANEL BOARD MUST BE OFFSET UP.

4: USE 5/16 X 4-1/2" HEX BOLTS AND 5/16" WASHERS TO ATTACH THE TOP HOLES OF THE BOTTOM PANEL BOARD TO THE T-NUTS INSTALLED ON THE CORNER POSTS. THE BOTTOM HOLES WILL BE USED LATER.

5: LAY THE 2 X 4 X 36-3/4" TOP PANEL BOARD ON TOP OF THE LEFT SIDE CORNER POSTS.

6: USE 5/16 X 4-1/2" HEX BOLTS AND 5/16" WASHERS TO ATTACH THE COUNTERSUNK HOLES OF THE TOP PANEL BOARD TO THE T-NUTS INSTALLED ON THE CORNER POSTS.

7: DO NOT INSTALL LAG SCREWS AT THIS TIME.

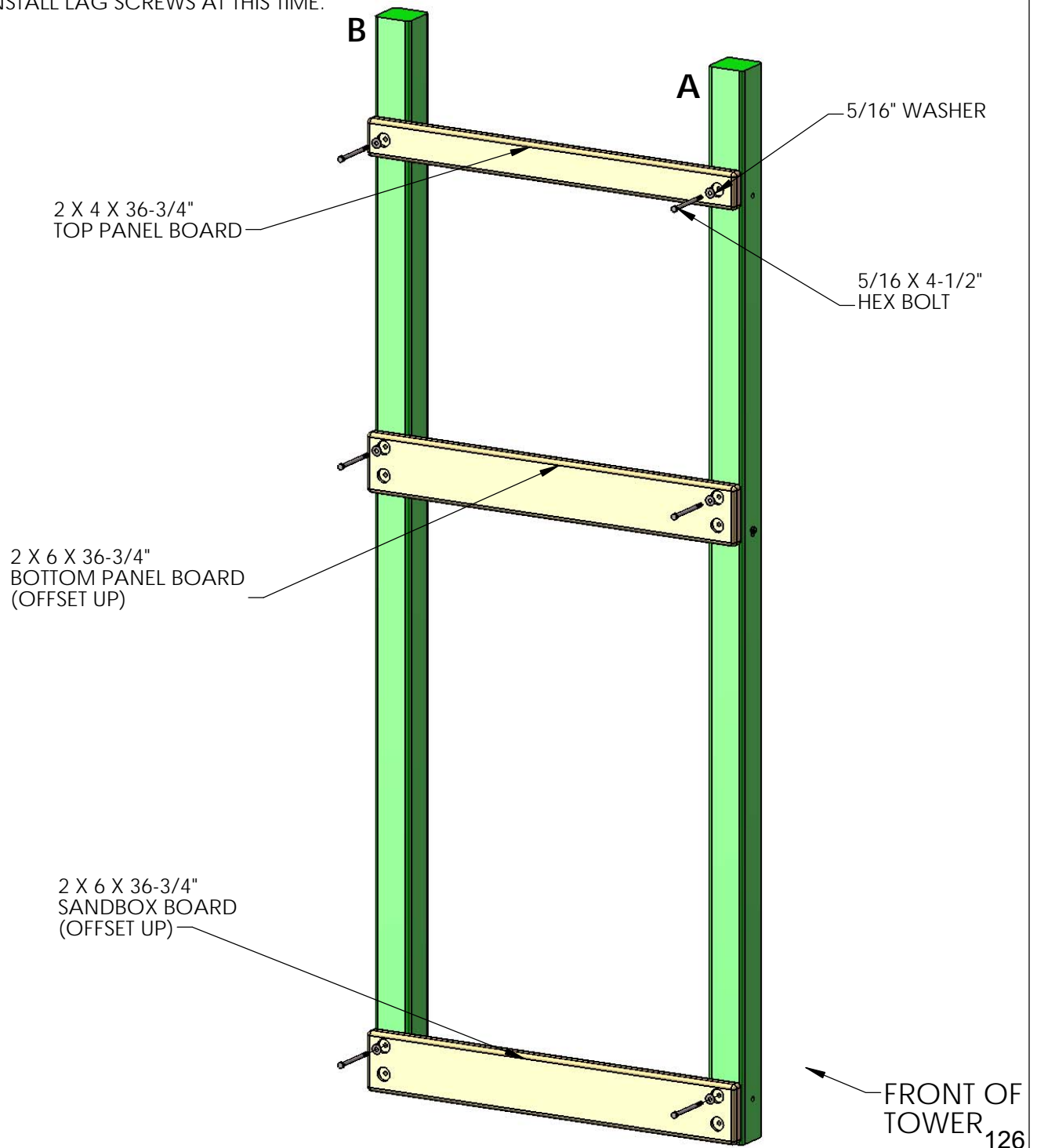

## STEP 4: DRILLING CHAIN HOLES

- 1: LOCATE **TWO** 2 X 4 X 36-3/4" BOTTOM PANEL/DECK SUPPORT BOARDS.
- 2: PLACE ONE OF THE BOARDS WITH THE COUNTERSUNK HOLES FACING UP OVER A SCRAP 2 X 4 BOARD. THE SCRAP BOARD WILL HELP PREVENT THE PADDLE BIT FROM SPLINTERING OUT THE BACK SIDE OF THE BOARD.
- 3: MEASURE AND MAKE A MARK AT THE LOCATIONS SHOWN BELOW.
- 4: DRILL A 1" DIAMETER HOLE WITH A PADDLE BIT AT EACH LOCATION THROUGH THE BOARD.
- 5: REPEAT SUBSTEPS 2 TO 4 FOR THE SECOND BOARD.

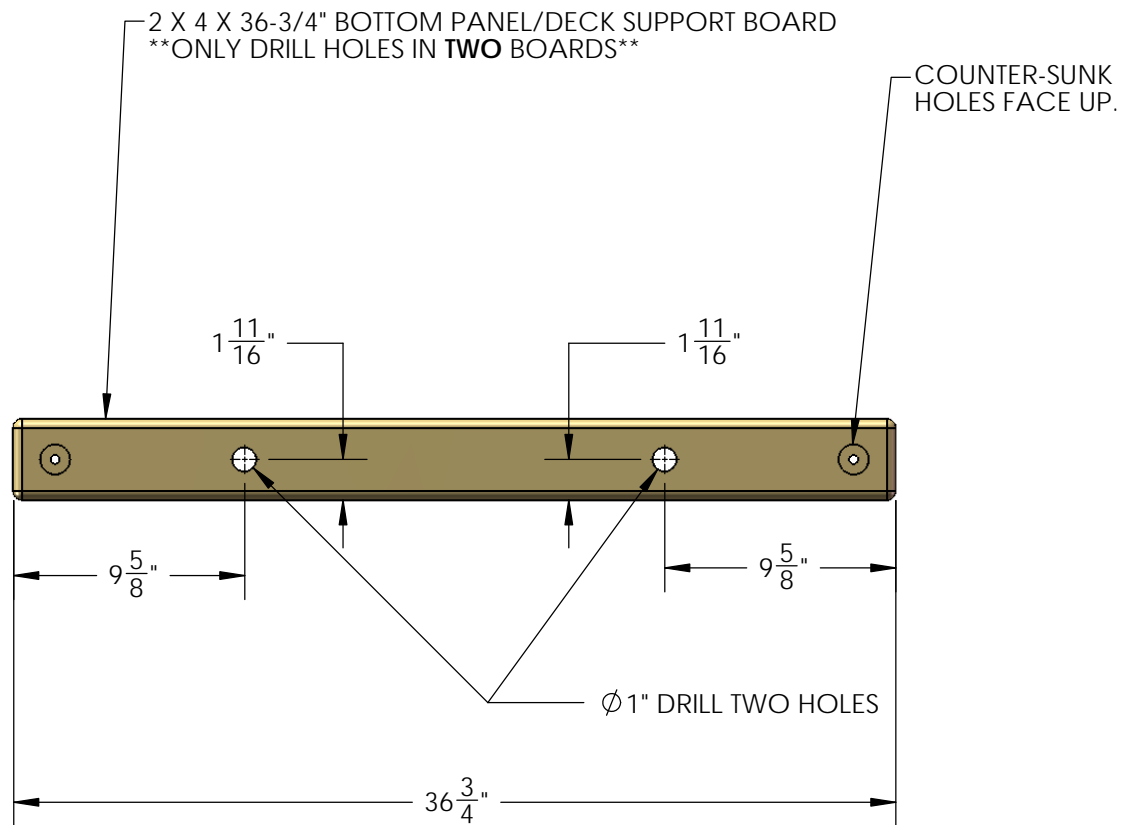

## STEP 5: DECK SUPPORTS

YOU WILL NEED AN EXTRA PERSON FOR THIS STEP.

1: WITH HELP, STAND UP THE LEFT AND RIGHT SIDE ASSEMBLIES.

2: FASTEN THE 2 X 4 X 36-3/4" DECK SUPPORTS TO THE HOLES AT 54-1/2" WITH 5/16 X 4-1/2" HEX BOLTS AND 5/16" WASHERS FROM THE INSIDE OF THE CORNER POST.

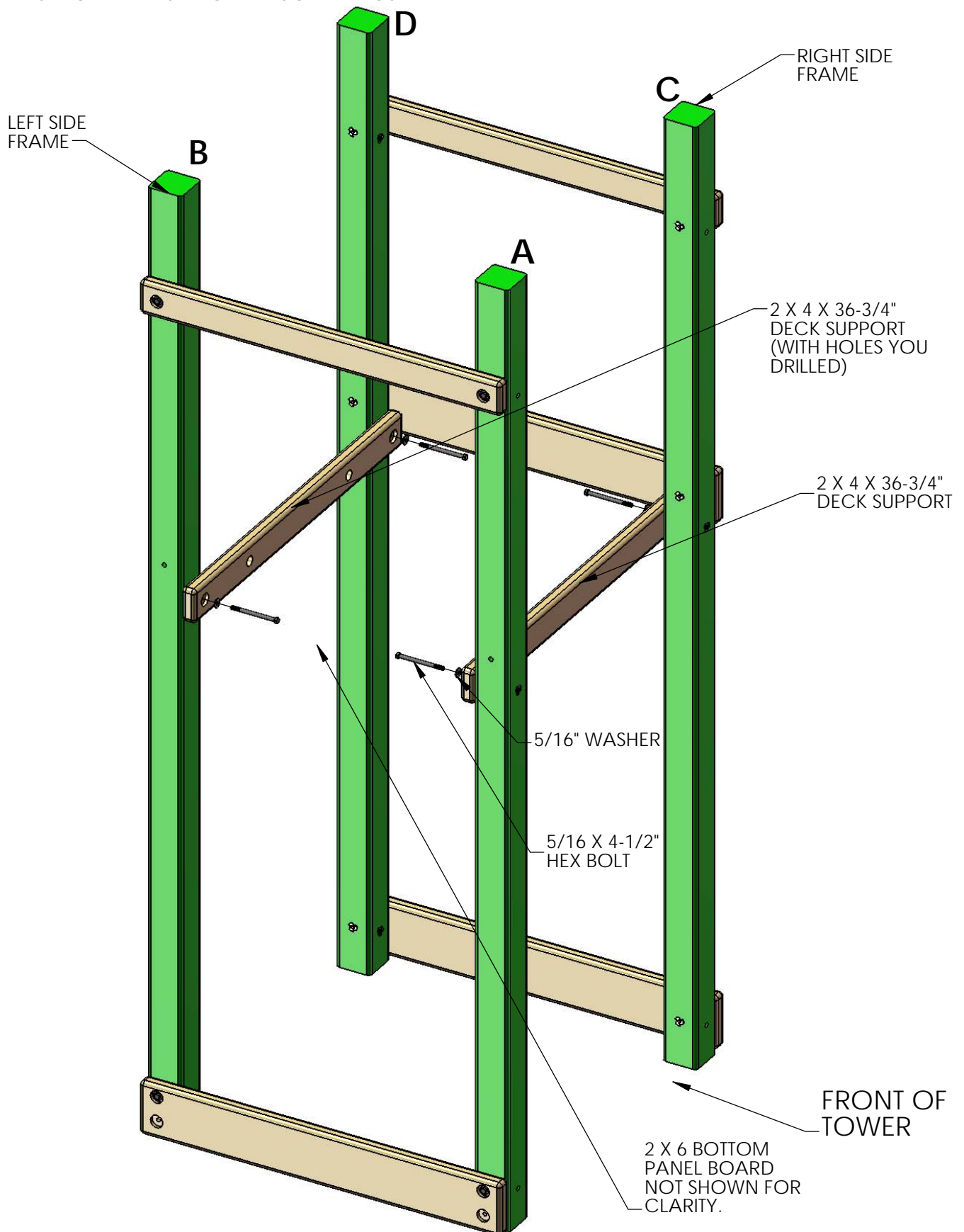



## STEP 6: FRONT FRAME ASSEMBLY

1: PLACE THE 2 X 6 X 36-3/4" SANDBOX BOARD ON THE FRONT OF THE CORNER POSTS. THE HOLES IN THE SANDBOX BOARD SHOULD BE OFFSET DOWN.

2: USE 5/16 X 4-1/2" HEX BOLTS AND 5/16" WASHERS TO ATTACH THE TOP HOLES OF THE SANDBOX BOARD TO THE T-NUTS INSTALLED ON THE CORNER POSTS. THE BOTTOM HOLES WILL BE USED LATER.

3: PLACE THE 2 X 4 X 36-3/4" TOP PANEL BOARD ON THE FRONT OF THE CORNER POSTS.

4: USE 5/16 X 4-1/2" HEX BOLTS AND 5/16" WASHERS TO ATTACH THE HOLES OF THE TOP PANEL BOARD TO THE T-NUTS INSTALLED ON THE CORNER POSTS.

5: DO NOT INSTALL LAG SCREWS AT THIS TIME.

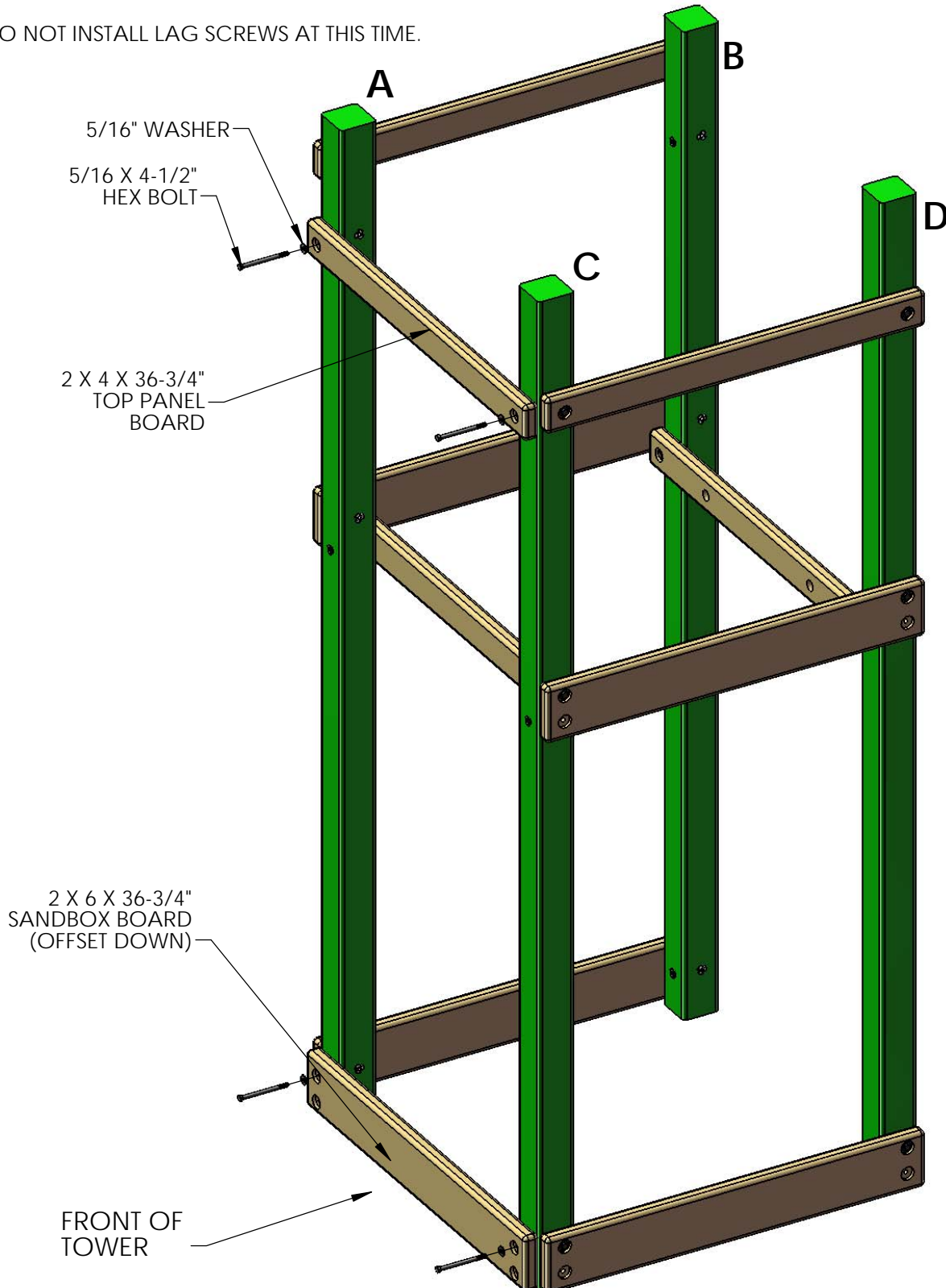

## STEP 7: REAR FRAME ASSEMBLY

1: PLACE THE 2 X 6 X 36-3/4" SANDBOX BOARD ON THE REAR OF THE CORNER POSTS. THE HOLES IN THE SANDBOX BOARD SHOULD BE OFFSET DOWN.

2: USE 5/16 X 4-1/2" HEX BOLTS AND 5/16" WASHERS TO ATTACH THE TOP HOLES OF THE SANDBOX BOARD TO THE T-NUTS INSTALLED ON THE CORNER POSTS. THE BOTTOM HOLES WILL BE USED LATER.

3: PLACE THE 2 X 4 X 36-3/4" TOP PANEL BOARD ON THE REAR OF THE CORNER POSTS.

4: USE 5/16 X 4-1/2" HEX BOLTS AND 5/16" WASHERS TO ATTACH THE HOLES OF THE TOP PANEL BOARD TO THE T-NUTS INSTALLED ON THE CORNER POSTS.

5: DO NOT INSTALL LAG SCREWS AT THIS TIME.

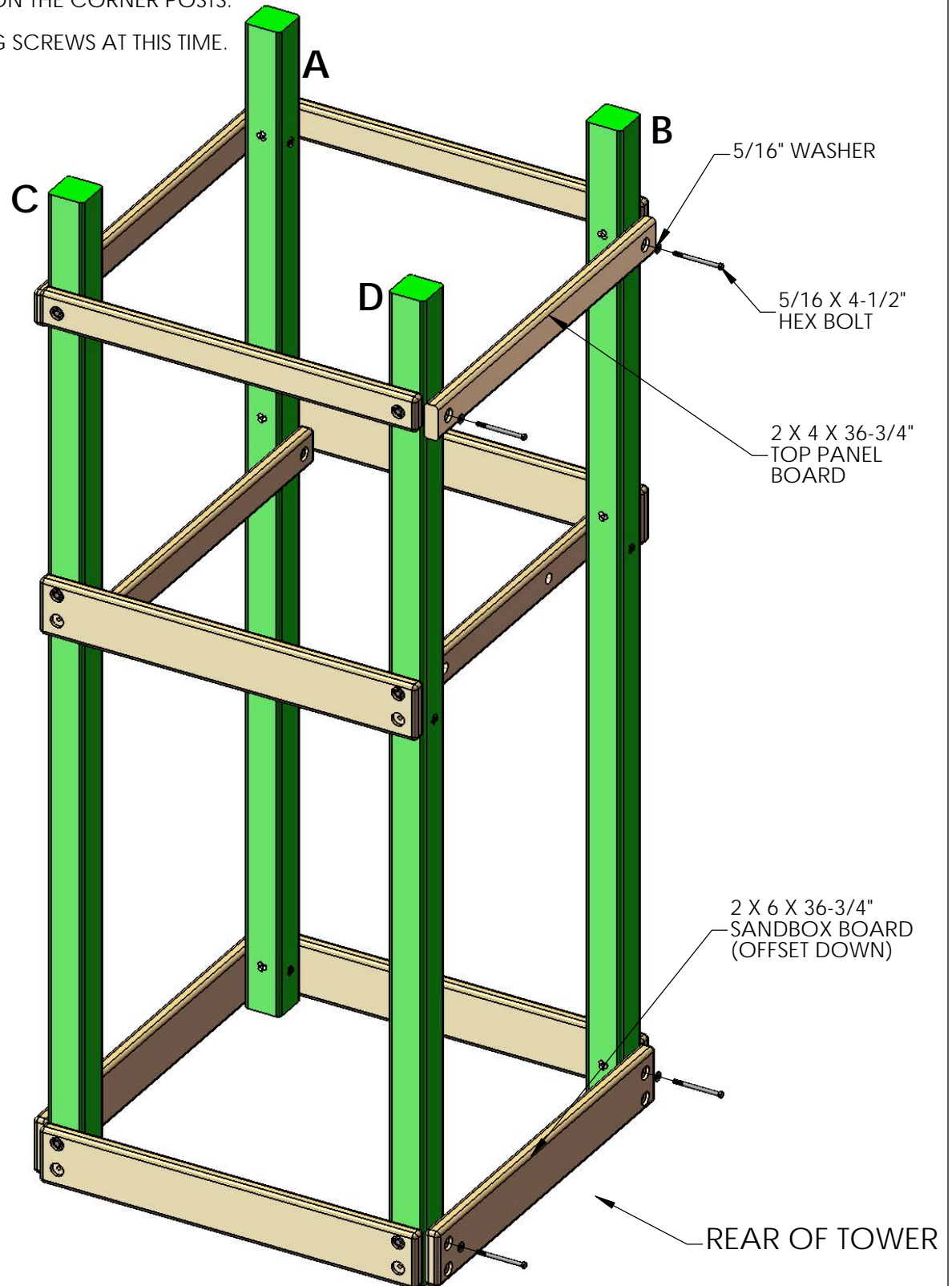

## STEP 8: LAG SCREWS

1: PLACE THE FRAME IN ITS FINAL POSITION AND FOLLOW THE PROCEDURES AT THE FRONT OF THE MANUAL TO LEVEL AND SQUARE THE STRUCTURE. TO SQUARE AND LEVEL THE DECK OF THE TOWER TO THE DECK OF THE FORT PLACE A DECK BOARD ACROSS THE 2 X 4'S. THEN PLACE A 2 X 4 X 66" BRIDGE RAIL ON TOP OF THE DECK BOARD AND ON TOP OF THE FORT DECK. PLACE A LEVEL ON TOP OF THE 66" BRIDGE RAIL, THEN MAKE THE DECKS LEVEL TO ONE ANOTHER.

2: ONCE THE FRAME IS LEVEL, SQUARE, AND SET INTO POSITION; GO BACK AND INSERT THE 5/16 X 3-1/2" LAG SCREWS AND 5/16" WASHERS IN THE REMAINING HOLES OF THE 2 X 6 PARTS SHOWN BELOW. NOTE: THERE WILL NOT BE ANY PREDRILLED HOLES IN THE CORNER POSTS FOR THE LAG SCREWS. LAG SCREWS ARE SELF-TAPPING.

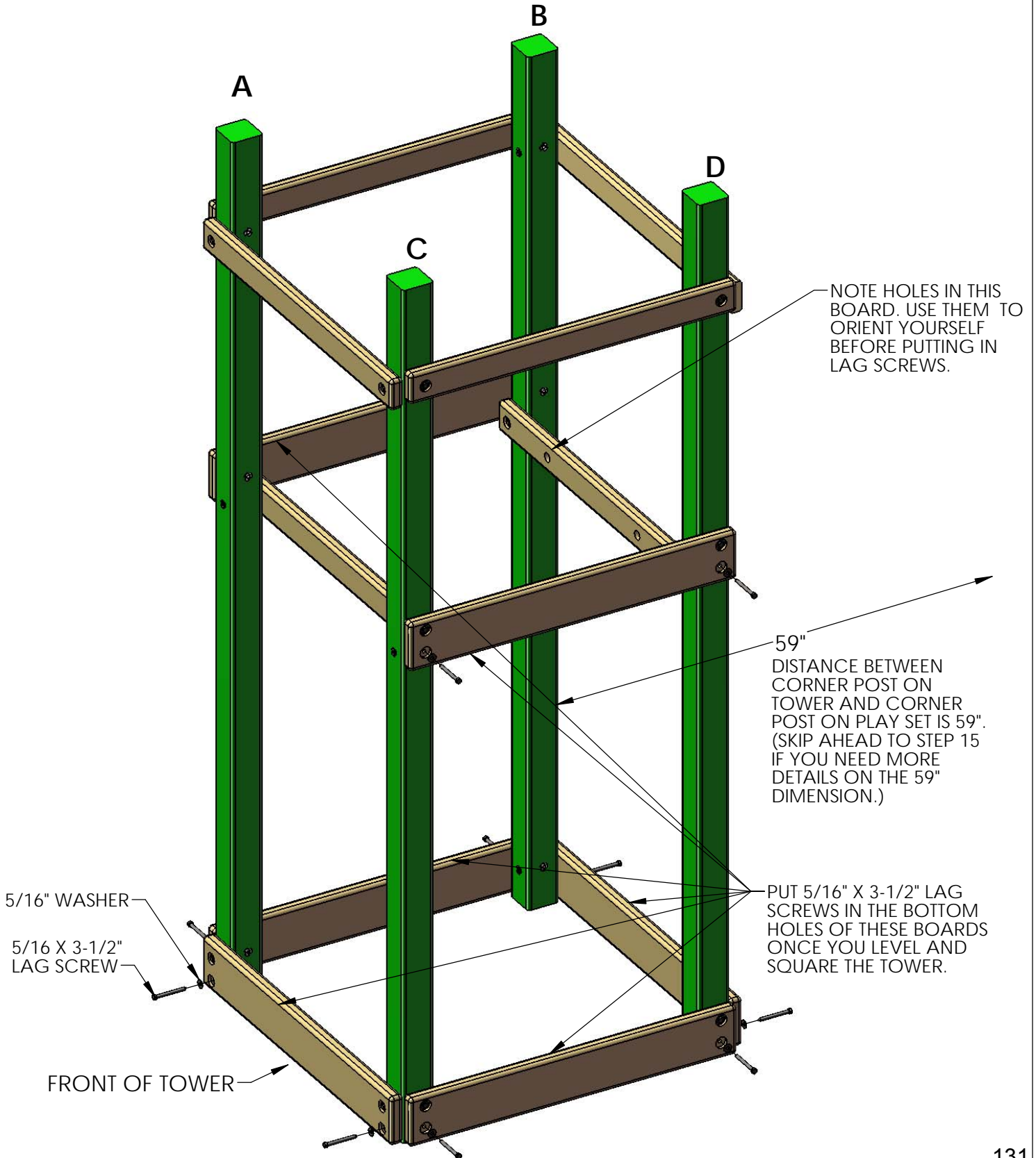

# STEP 9: DECK BOARDS

THE FOLLOWING STEP IS RECOMMENDED TO PREVENT POSSIBLE SPLITS IN THE WOOD

1: PRE-DRILL THE ENDS OF THE DECK SPACERS AND DECKBOARDS TO PREVENT INSTALLATION DAMAGE. PRE-DRILL BOTH ENDS WITH A 1/8" DRILL BIT USING THE DIMENSIONS SHOWN BELOW.

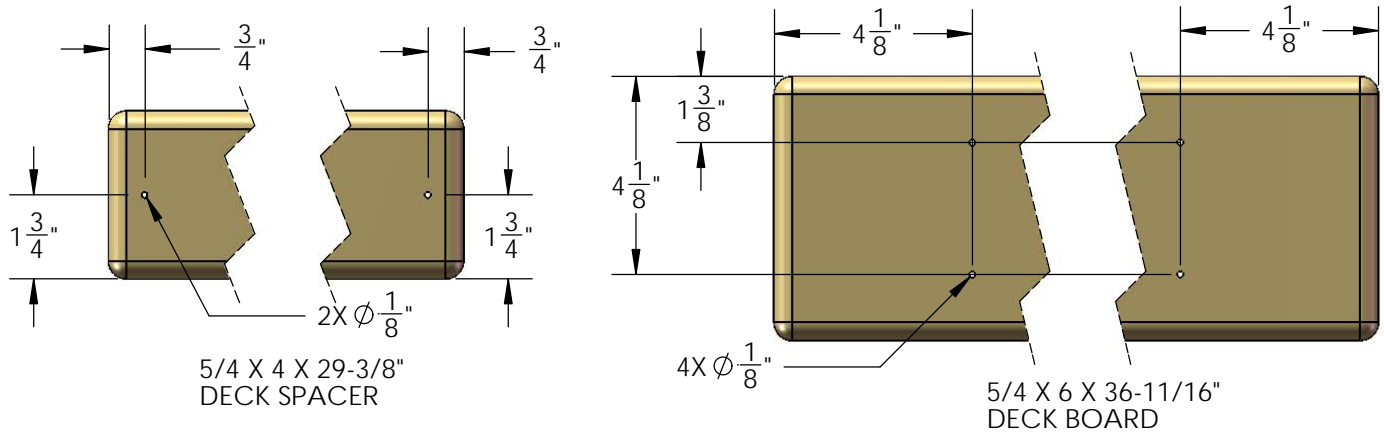

2: PLACE THE 5/4 X 4 X 29-3/8" DECK SPACERS BETWEEN THE CORNER POSTS. MAKE EACH DECK SPACER FLUSH TO THE INSIDE SURFACE OF THE 2 X 6. ATTACH EACH DECK SPACER TO THE DECK SUPPORTS WITH TWO 2" WOOD SCREWS. NOTE THE TOP OF THE SCREW HEAD SHOULD BE FLUSH WITH THE TOP OF THE DECK SPACER.

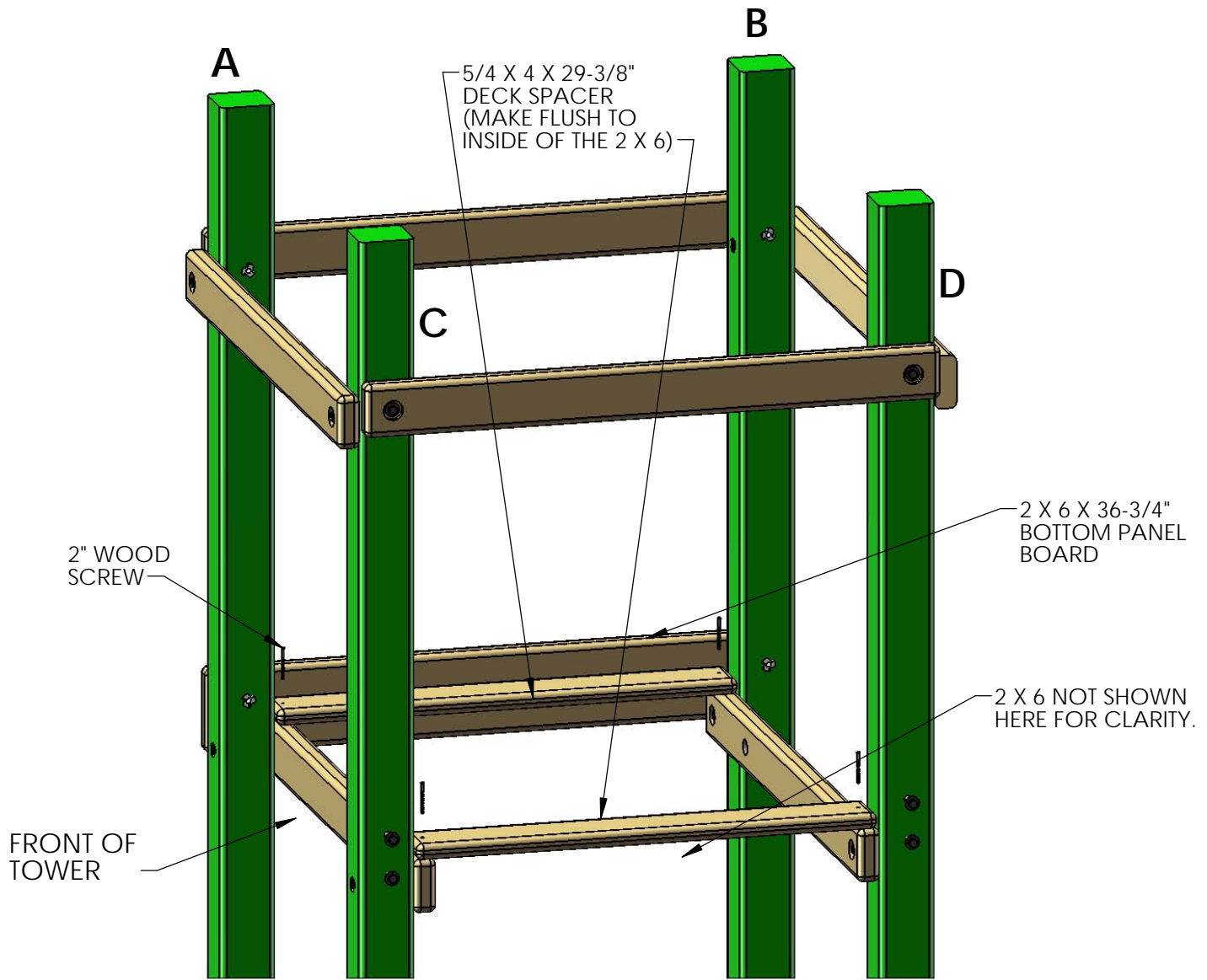

## STEP 10: FRONT FACE BOARD

1: PLACE THE 5/4 X 6 X 36-11/16" DECK BOARDS ON TOP OF THE DECK SUPPORTS. DO NOT FASTEN THE DECK BOARDS AT THIS TIME.

2: PLACE THE 2 X 4 X 36-3/4" BOTTOM PANEL BOARD AGAINST THE FRONT CORNER POSTS, AND LEVEL THE TOP OF THE BOARD WITH THE TOP OF THE DECK BOARDS.

3: FASTEN THE BOTTOM PANEL BOARD TO THE CORNER POSTS WITH 5/16 X 3-1/2" LAG SCREWS WITH 5/16" WASHERS.

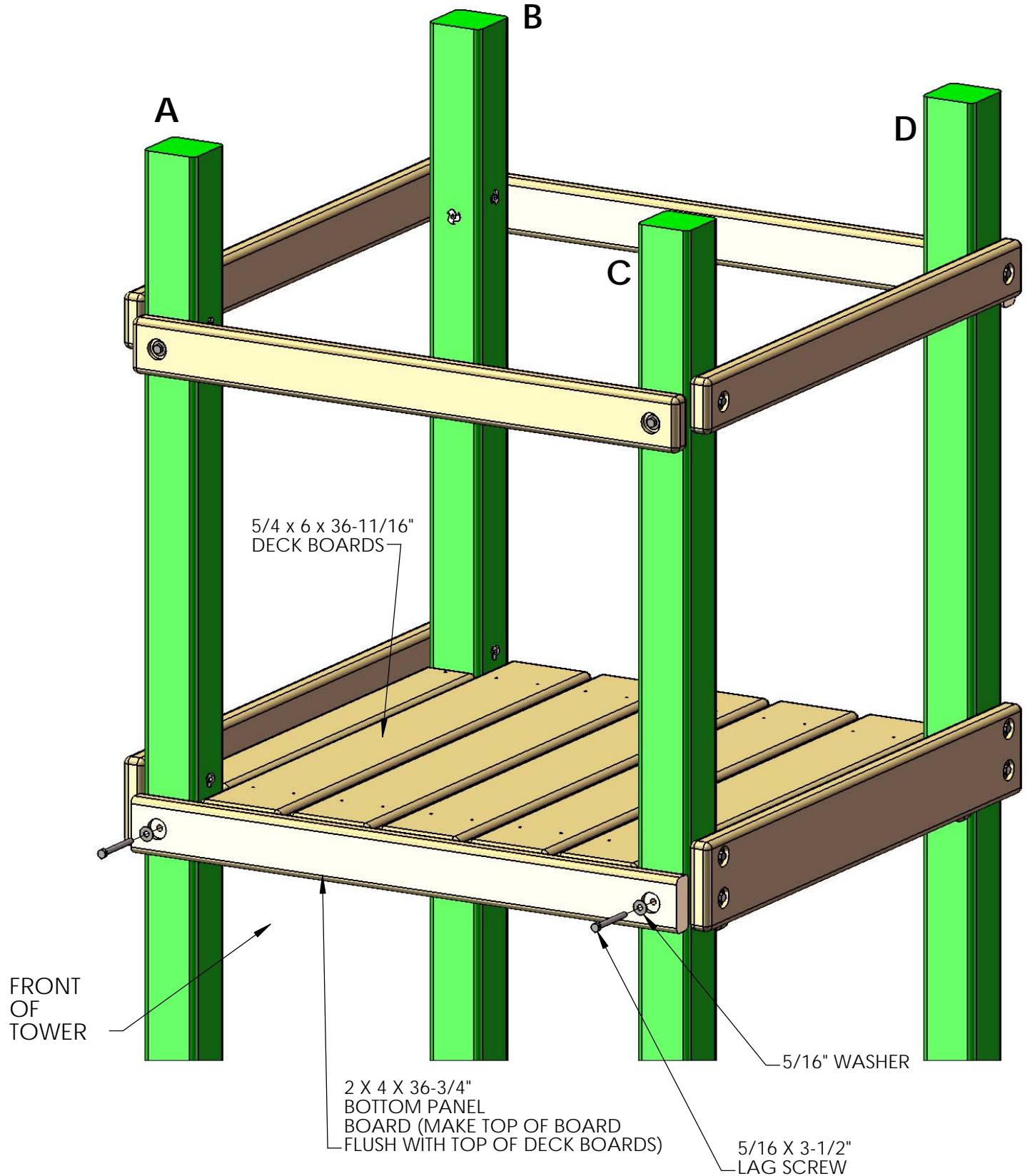

# STEP 11: DECK

1: INSTALL THE 5/4 X 6 X 36-11/16" DECK BOARDS. LEAVE A UNIFORM (APPROXIMATELY 5/16") SPACE BETWEEN THE DECK BOARDS. ATTACH THE DECK BOARDS TO THE DECK SUPPORTS WITH WITH 2" WOOD SCREWS.

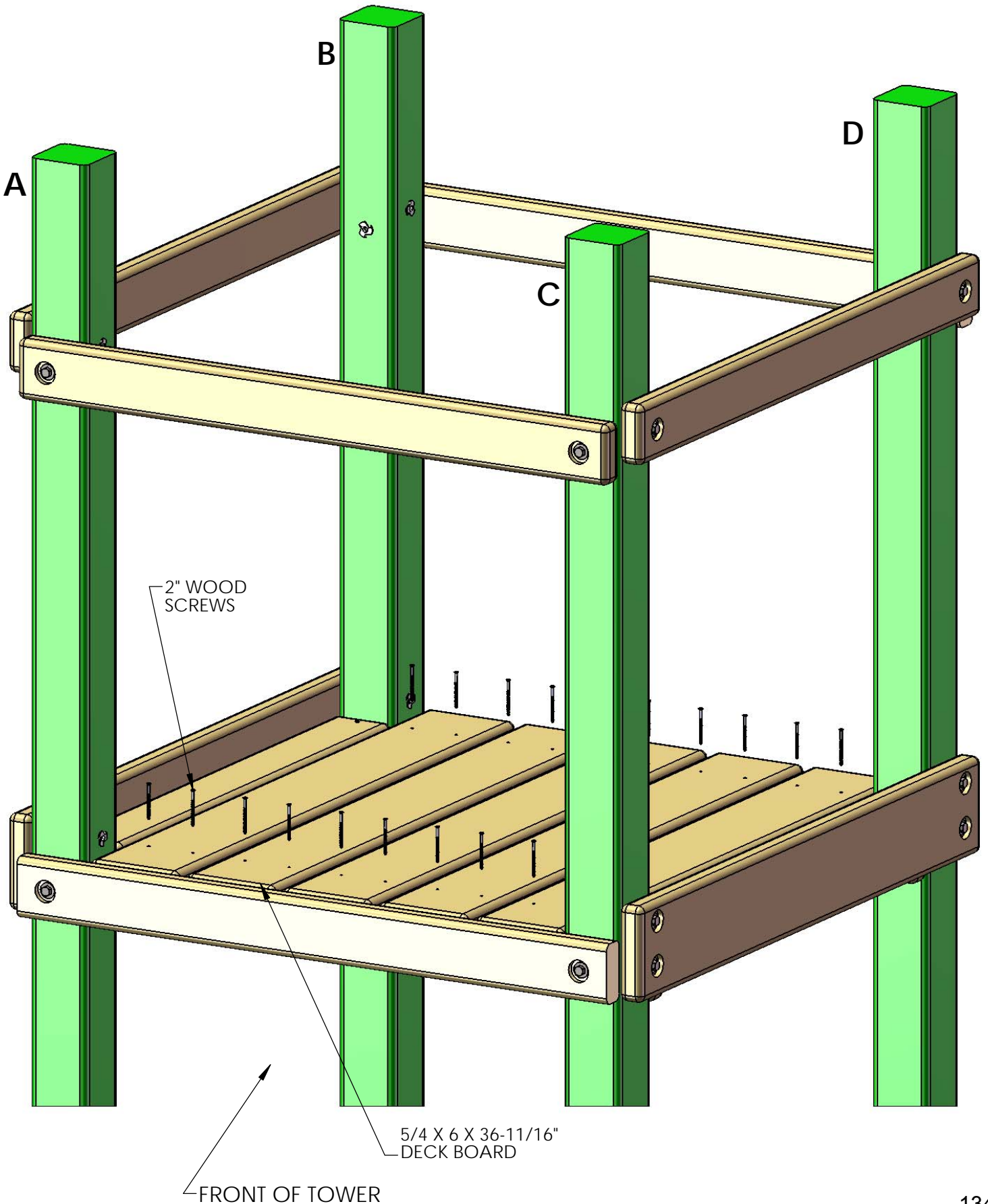

## STEP 12: REAR BOTTOM PANEL BOARD

1: PLACE THE 2 X 4 X 36-3/4" BOTTOM PANEL BOARD (WITH HOLES YOU DRILLED) AGAINST THE REAR CORNER POSTS, AND LEVEL THE TOP OF THE BOARD WITH THE TOP OF THE DECK BOARDS.

2: FASTEN THE BOTTOM PANEL BOARD TO THE CORNER POSTS WITH 5/16 X 3-1/2" LAG SCREWS WITH 5/16" WASHERS.

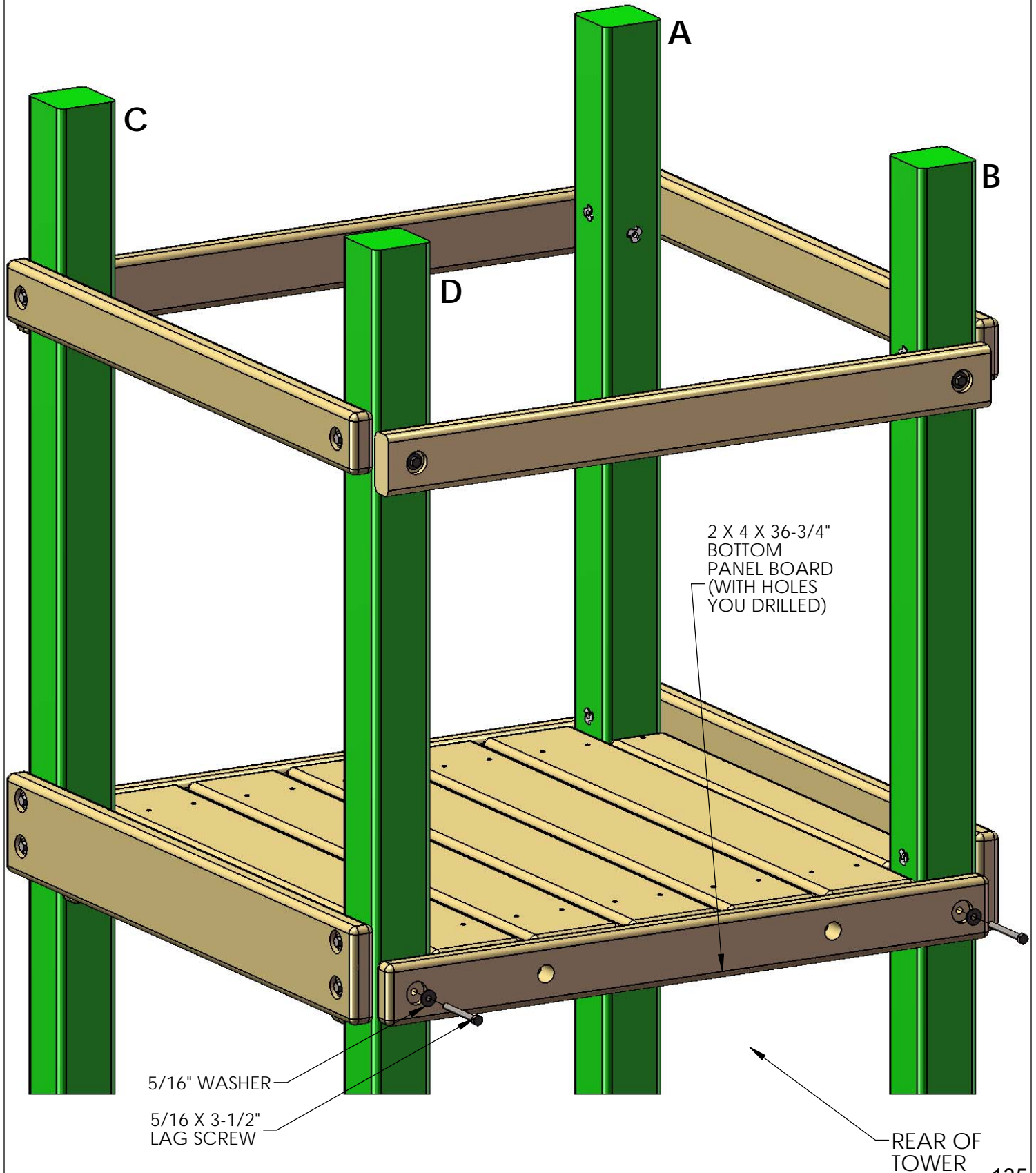

# STEP 13: PANEL SLATS

1: FIND TEN 5/4 X 3 X 28-1/2" PANEL SLATS.

2: PRE-DRILL THE PANEL SLATS 1" FROM EACH END ON CENTER WITH A 1/8" DRILL BIT. (SEE TOP LEFT PICTURE BELOW)

3: INSTALL THE FIRST PANEL SLAT 2-1/2" FROM THE CORNER POST. THEN INSTALL THE REMAINING FOUR PANEL SLATS 2-7/8" APART AS SHOWN IN THE PICTURE AT THE BOTTOM LEFT BELOW.

4: ATTACH THE PANEL SLATS WITH 2" WOOD SCREWS IN THE PRE-DRILLED HOLES TO THE RIGHT SIDE OF THE TOWER.

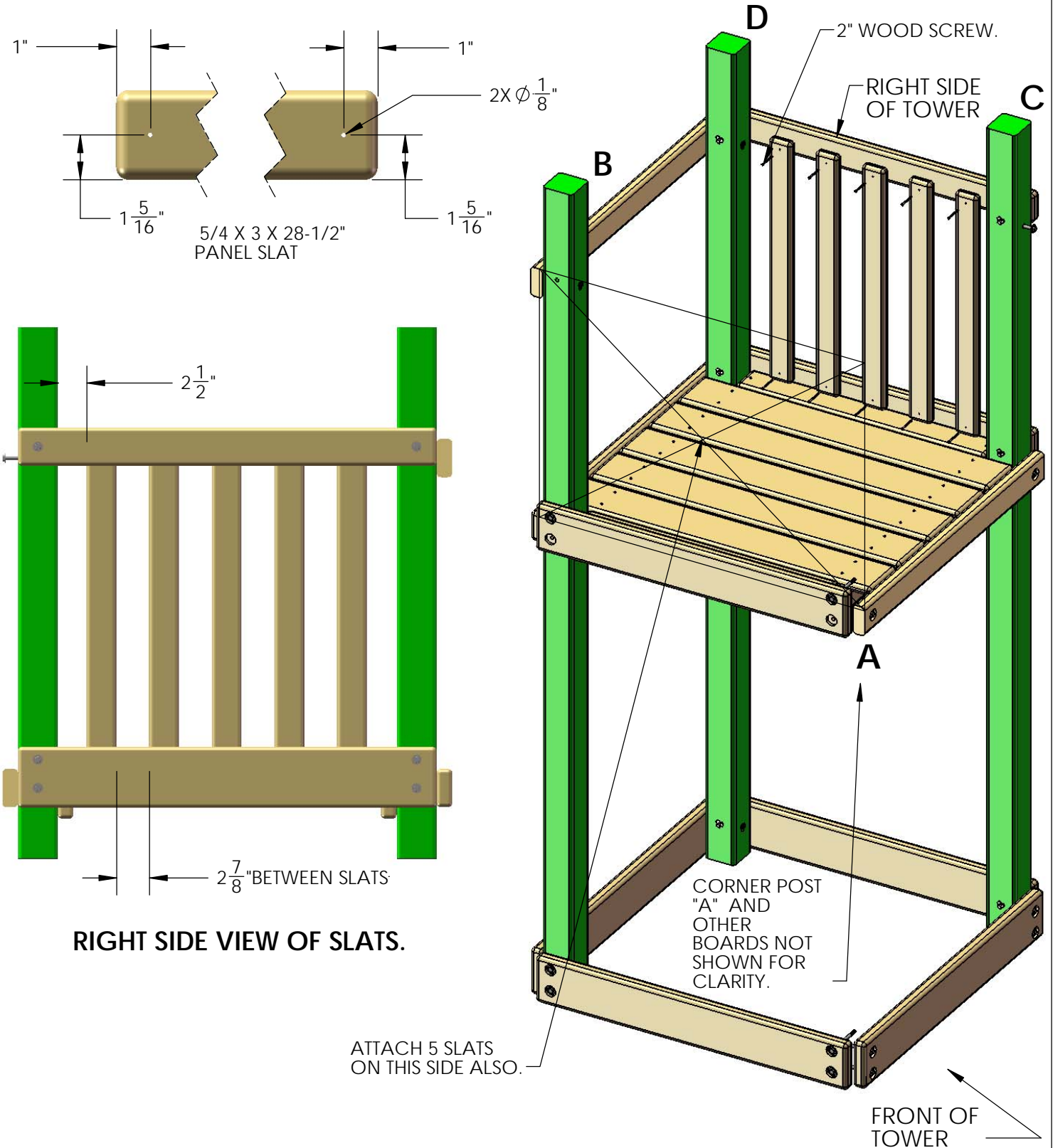



## STEP 14: BRIDGE RAILS

- 1: PLACE THE TOP SURFACE OF THE UPPER TWO 2 X 4 X 66" BRIDGE RAILS 5-1/2" BENEATH THE TOP SURFACE OF THE TOP PANEL BOARD. THE COUNTERSUNK HOLE IN THE END OF THE BRIDGE RAIL SHOULD FACE THE INSIDE. FASTEN THE BRIDGE RAIL TO THE CORNER POST WITH 5/16" X 3-1/2" LAG SCREWS WITH 5/16" WASHERS.
- 2: MEASURE 16" FROM THE TOP OF EACH BRIDGE RAIL AND MAKE A PENCIL MARK ON THE INSIDE OF THE CORNER POSTS.
- 3: PLACE THE BOTTOM OF EACH LOWER 2 X 4 X 66" BRIDGE RAIL ON THE MARK ON THE CORNER POST. FASTEN EACH BRIDGE RAIL TO THE CORNER POST WITH 5/16" X 3-1/2" LAG SCREWS WITH 5/16" WASHERS.

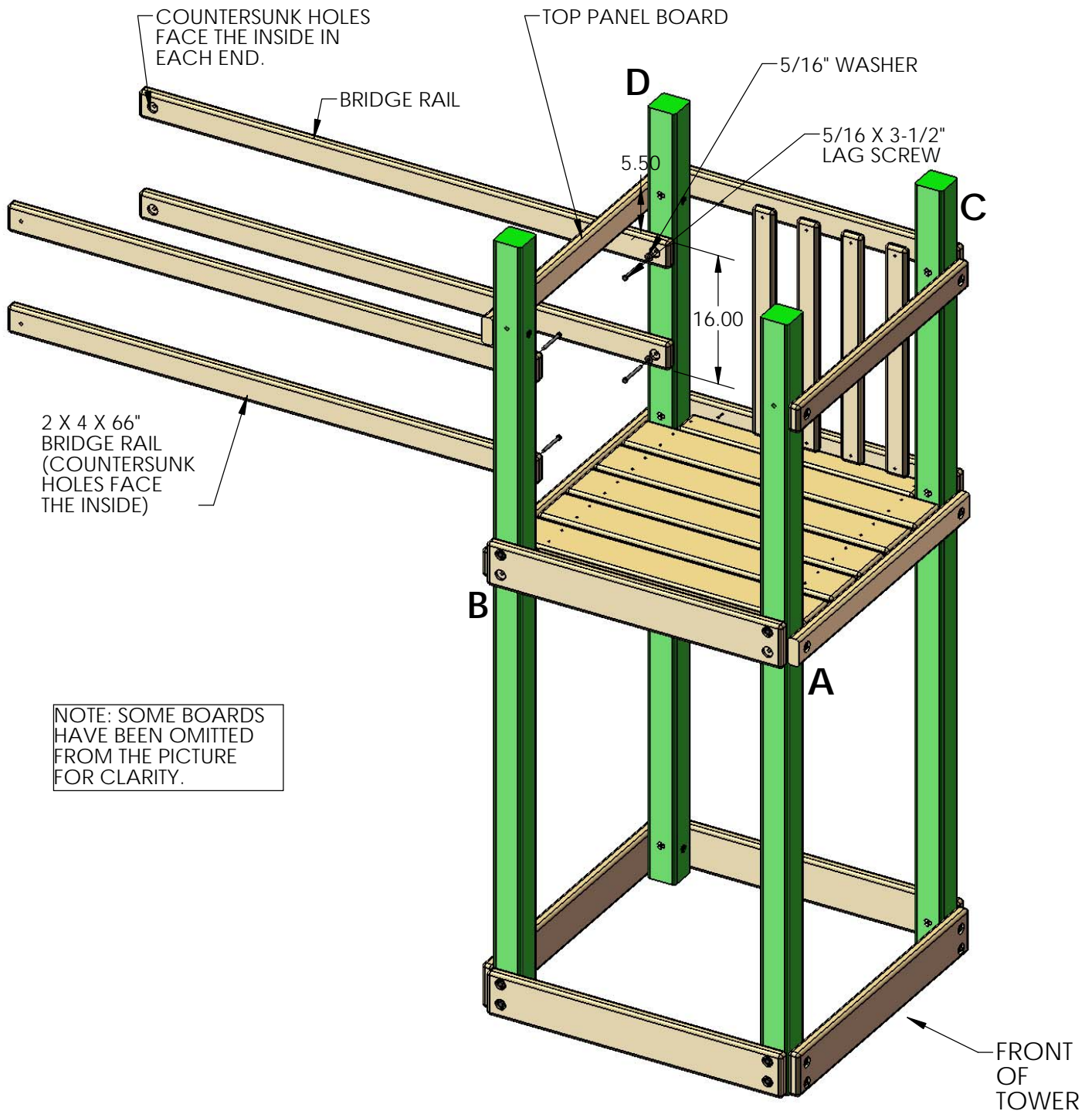

## STEP 15: BRIDGE RAILS TO PLAY SET

- 1: PLACE THE BRIDGE RAILS AGAINST THE GREEN CORNER POST AND CENTER CORNER POST ON THE PLAY SET.
- 2: LEVEL EACH TOP BRIDGE RAIL AND ATTACH THEM TO THE CORNER POSTS WITH 5/16" X 3-1/2" LAG SCREWS AND 5/16" WASHERS.
- 3: MAKE THE BOTTOM OF EACH LOWER BRIDGE RAIL 16" FROM THE TOP OF THE TOP BRIDGE RAIL.
- 4: ATTACH EACH LOWER BRIDGE RAIL TO THE CORNER POSTS WITH 5/16" X 3-1/2" LAG SCREWS AND 5/16" WASHERS.

ATTACH TOP AND LOWER BRIDGE RAILS TO CORNER POSTS ON EACH SIDE WITH 5/16" X 3-1/2" LAG SCREWS AND 3/8" WASHERS

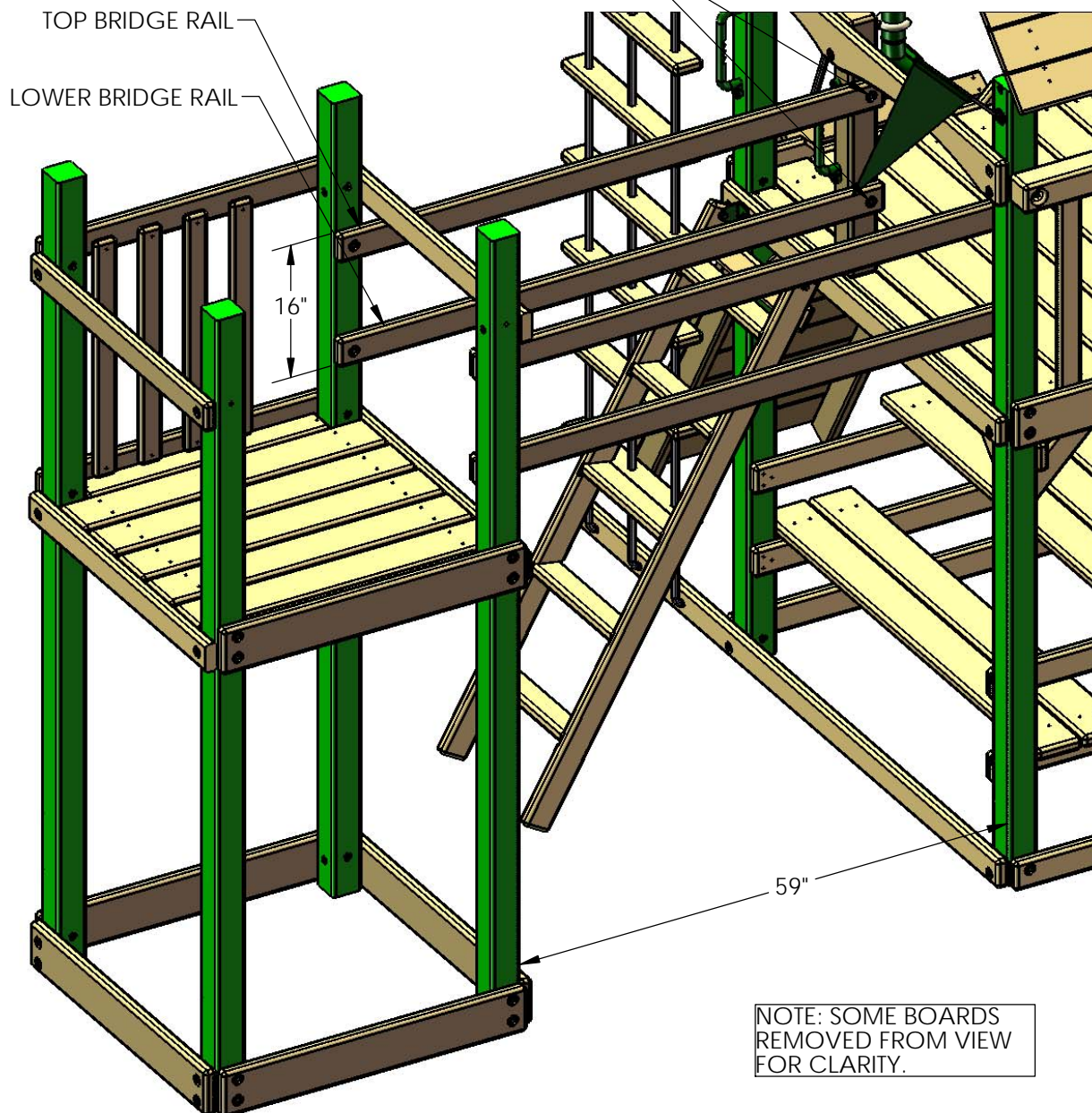

## STEP 16: BRIDGE RAIL SLATS

1. PRE-DRILL TWENTY 5/4 X 3 X 16" BRIDGE RAIL SLATS ON EACH END WITH A 1/8" DRILL BIT. (SEE TOP IMAGE BELOW)
2. PLACE THE BRIDGE RAIL SLATS 3" FROM THE FACE OF THE CORNER POSTS, AND ATTACH WITH 2" WOOD SCREWS. THE SLATS WILL MOUNT ON THE OUTSIDE OF THE BRIDGE RAILS.
3. ATTACH THE REMAINING SLATS TO THE UNIT WITH 3" SPACING BETWEEN THE SLATS.

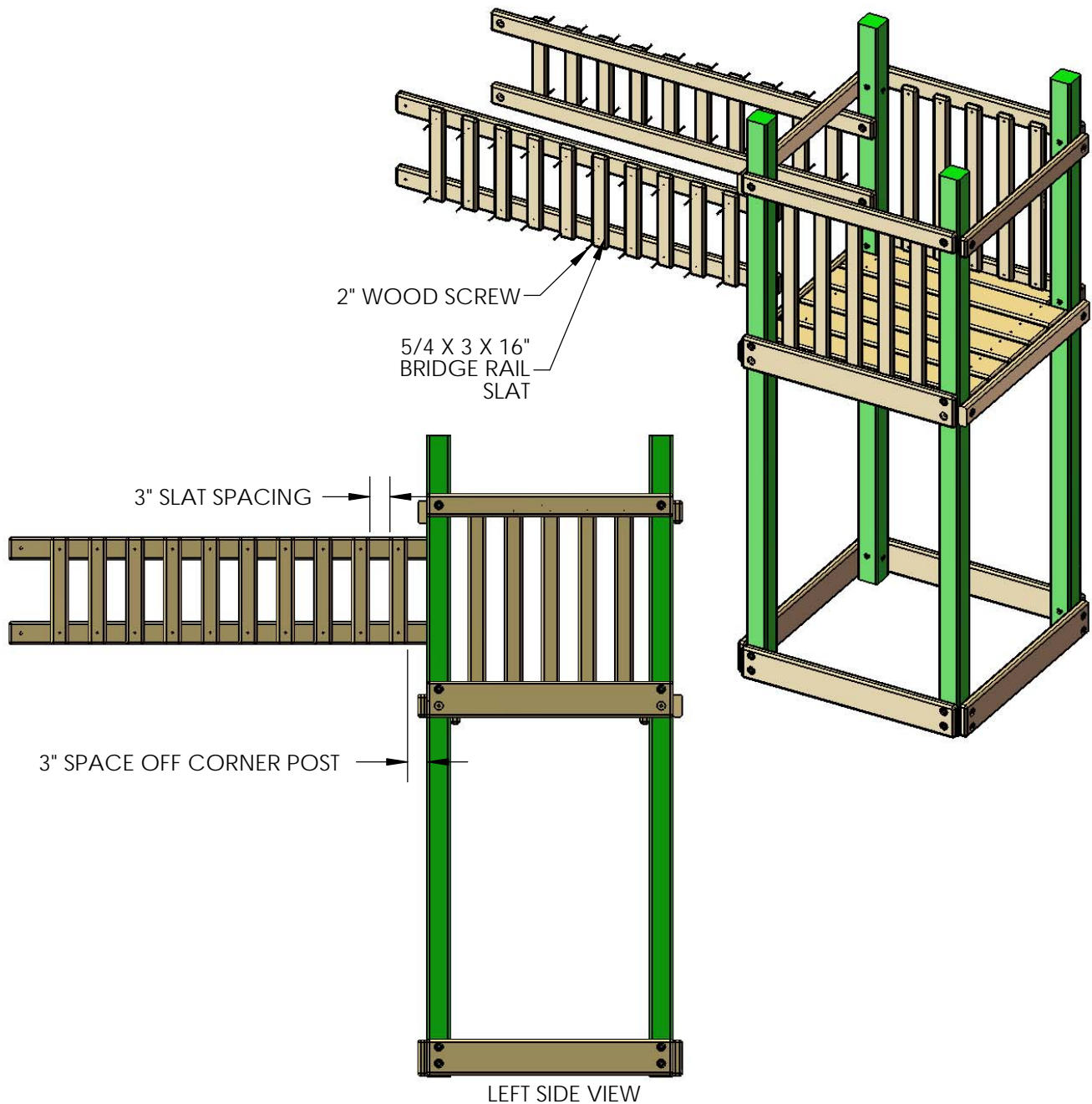
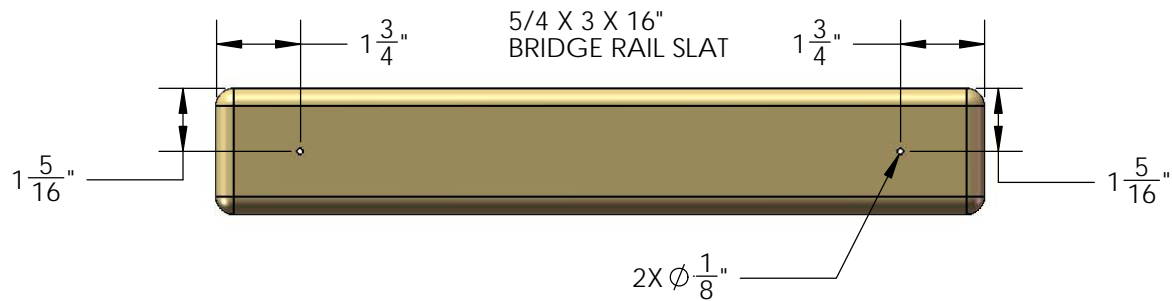

## STEP 17: BRIDGE DECK AND CHAIN ASSEMBLY

1: FIND FIFTEEN 2 X 4 X 29" BRIDGE DECK BOARDS AND INSERT T-NUTS INTO THE PRE-DRILLED HOLES. USE A HAMMER TO SEAT THE T-NUTS INTO THE BOARDS.

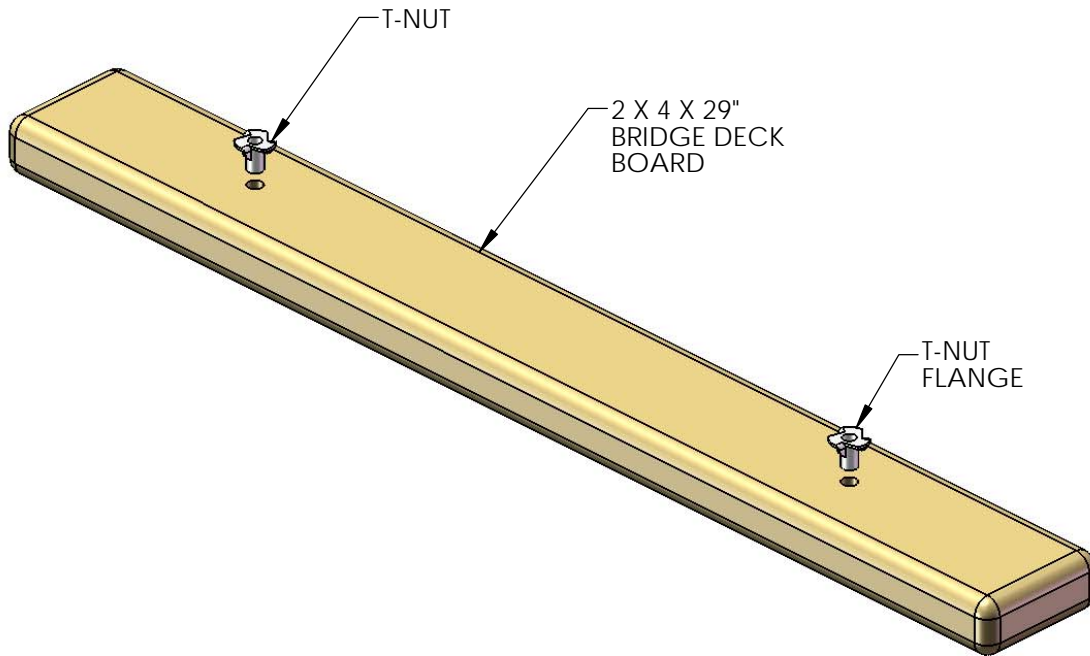

2: FLIP ALL 15 BRIDGE DECK BOARDS OVER SO THAT THE FLANGE OF THE T-NUT IS FACING DOWN. LAY THE BRIDGE DECK BOARDS OUT ON A FLAT SURFACE AS SHOWN BELOW.

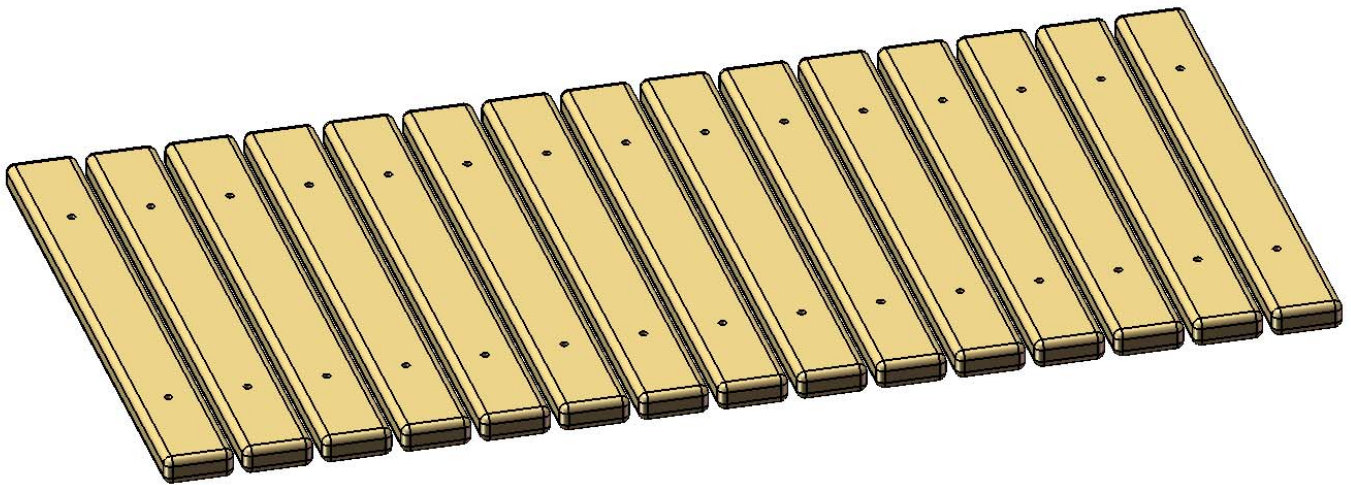

# STEP 18: BRIDGE DECK AND CHAIN ASSEMBLY

- 1: LOCATE TWO 96" CHAIN SECTIONS THAT SHIPPED WITH THE CLATTER BRIDGE.
- 2: PLACE THE CHAINS OVER THE HOLES IN THE BRIDGE DECK BOARDS AS SHOWN BELOW.
- 3: LINE UP THE 18TH LINK IN THE CHAINS WITH THE FIRST BRIDGE DECK BOARD HOLES.

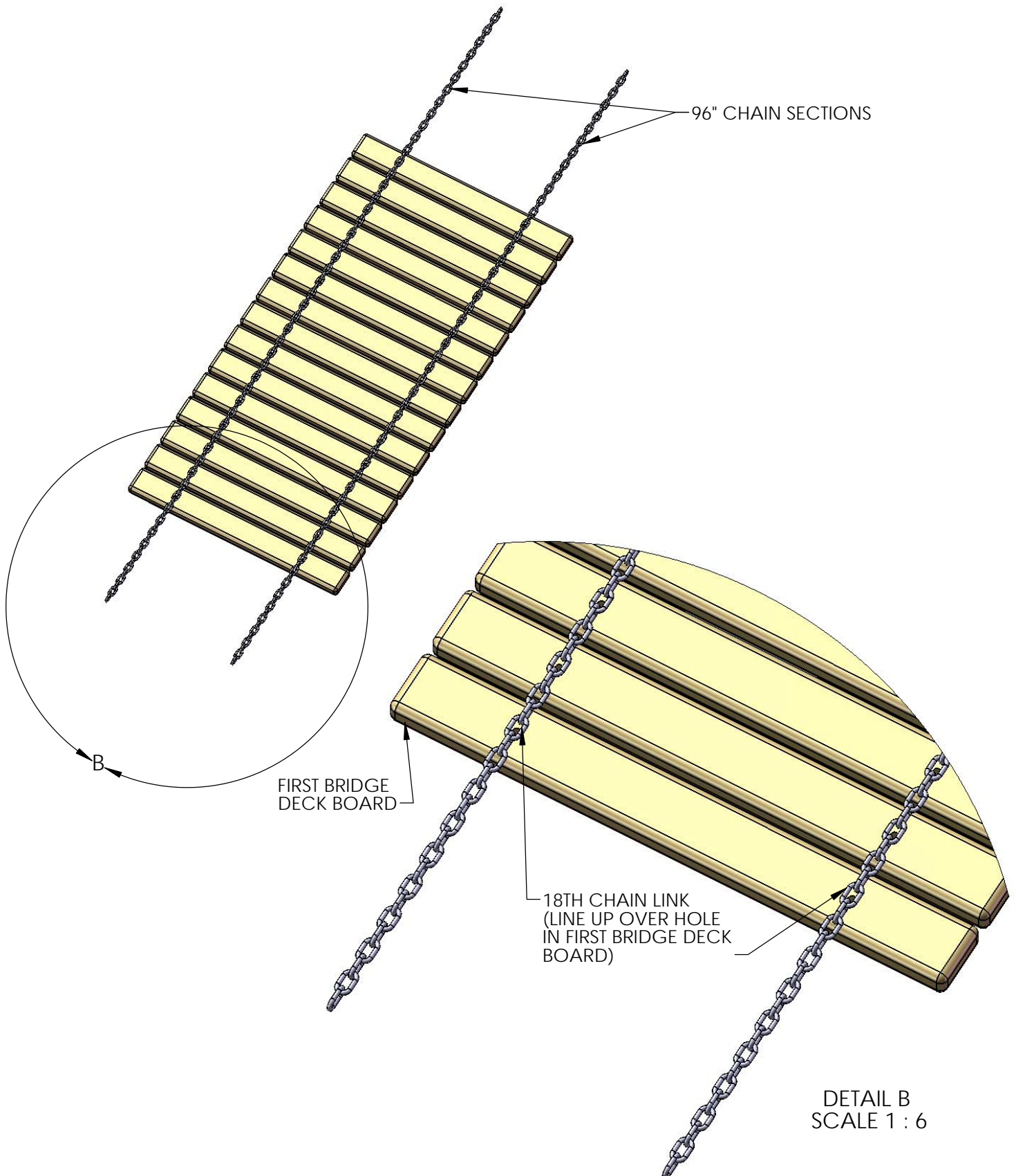

# STEP 19: BRIDGE DECK AND CHAIN ASSEMBLY

- 1: PLACE A 5/16" WASHER BETWEEN THE 18TH CHAIN LINK AND THE BRIDGE DECK BOARD.
- 2: PLACE A 5/16" X 1-3/4" HEX BOLT WITH 5/16" WASHER THROUGH THE 18TH CHAIN LINK, THEN THROUGH THE 5/16" WASHER, THEN THROUGH THE HOLE IN THE BRIDGE DECK BOARD AND SCREW IT INTO THE T-NUT. TIGHTEN THE BOLT BUT NOT SO TIGHT THAT YOU CRACK THE WOOD.
- 3: COUNT OVER 4 CHAIN LINKS FROM THE LAST HEX BOLT. AT THIS CHAIN LINK PLACE A 5/16" WASHER BETWEEN THE CHAIN LINK AND THE BRIDGE DECK BOARD. NOTE THAT THREE EMPTY CHAIN LINKS ARE BETWEEN THE BOLTS.
- 4: PLACE A 5/16" X 1-3/4" HEX BOLT WITH 5/16" WASHER THROUGH THE CHAIN LINK, THEN THROUGH THE 5/16" WASHER, THEN THROUGH THE HOLE IN THE BRIDGE DECK BOARD AND SCREW IT INTO THE T-NUT. TIGHTEN THE BOLT BUT NOT SO TIGHT THAT YOU CRACK THE WOOD.
- 5: REPEAT SUBSTEPS 3 & 4 UNTIL YOU HAVE SECURED THE CHAIN TO THE BRIDGE DECK BOARDS ALONG ONE SIDE. THEN START OVER WITH THE OTHER CHAIN AND REPEAT THIS ENTIRE PROCESS.

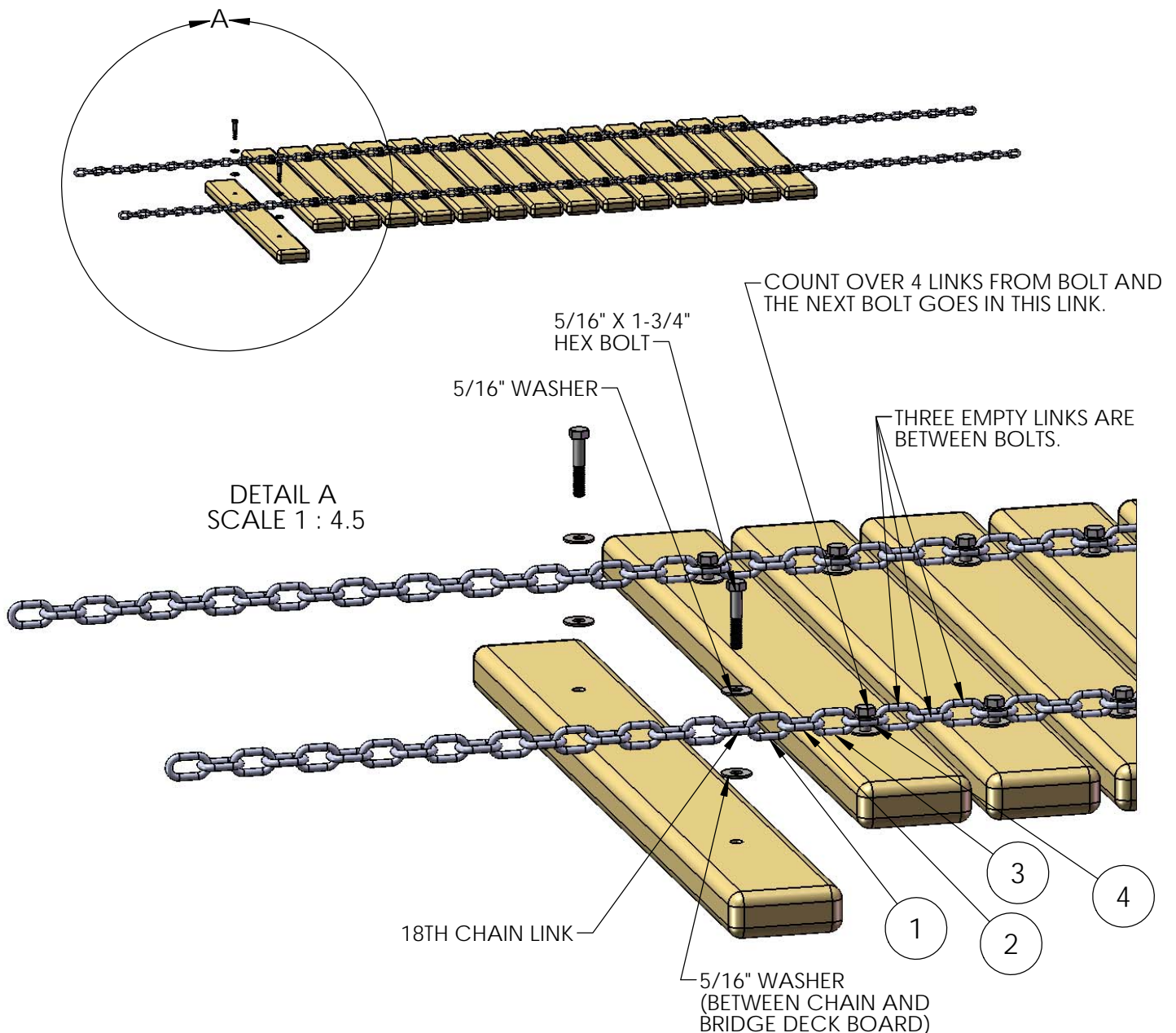

## STEP 20: BRIDGE DECK/CHAIN INSTALLATION

1: LAY THE BRIDGE DECK/CHAINS ASSEMBLY BETWEEN THE PLAY SET AND THE TOWER WITH THE CHAINS FACING THE GROUND. THREAD THE CHAIN ENDS IN THE BRIDGE DECK ASSEMBLY THROUGH THE HOLES IN THE BOTTOM PANEL BOARD AND DECK SUPPORT BOARD ON THE TOWER.

2: THERE SHOULD BE AT LEAST A 1" TO 1-3/4" GAP BETWEEN THE BRIDGE DECK BOARD AND THE BOTTOM PANEL BOARD ON THE TOWER. THIS MEANS THAT YOU WILL HAVE TO CONNECT THE ENDS OF THE CHAINS IN A MANNER TO ACHIEVE THE CORRECT GAP. GO UNDERNEATH THE TOWER DECK AND USE A QUICK LINK TO ATTACH THE CHAINS TOGETHER. IF YOU HAVE LOOSE ENDS OF THE CHAINS HANGING DOWN THREAD THEM THROUGH THE QUICK LINK TO KEEP THEM UP AND OUT OF THE WAY.



CHAIN MUST GO THROUGH TWO BOARDS NO EXCEPTIONS!!

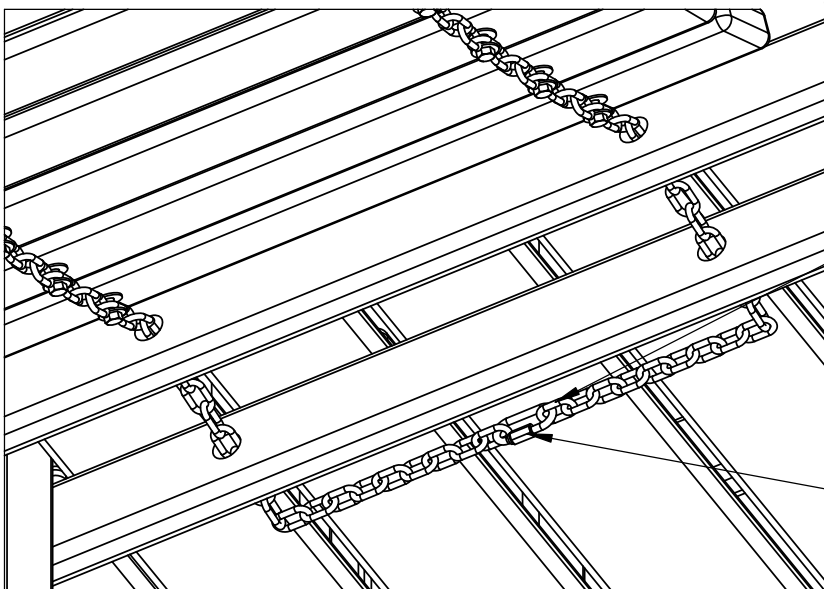

DETAIL A  
SCALE 1 : 6

NOTE: TO ACHIEVE THE CORRECT GAP YOU MAY NOT BE CONNECTING THE END LINK OF EACH CHAIN. FOR EXAMPLE YOU MAY HAVE TO CONNECT THE SECOND, THIRD OR FORTH LINKS TOGETHER.

QUICK LINK

## STEP 21: DRILLING HOLES IN FORT

1: MEASURE FOR THE HOLE LOCATIONS ON THE 2 X 4 X 58" BOTTOM PANEL BOARD AS SHOWN BELOW. NOTE THE BOTTOM PANEL BOARD WAS INSTALLED IN STEP 7 ON THE FRONT OF THE FORT.

2: USE A 1" DIAMETER SPADE (PADDLE BIT) OR AUGER STYLE BIT TO DRILL HOLES IN THE BOTTOM PANEL BOARD.

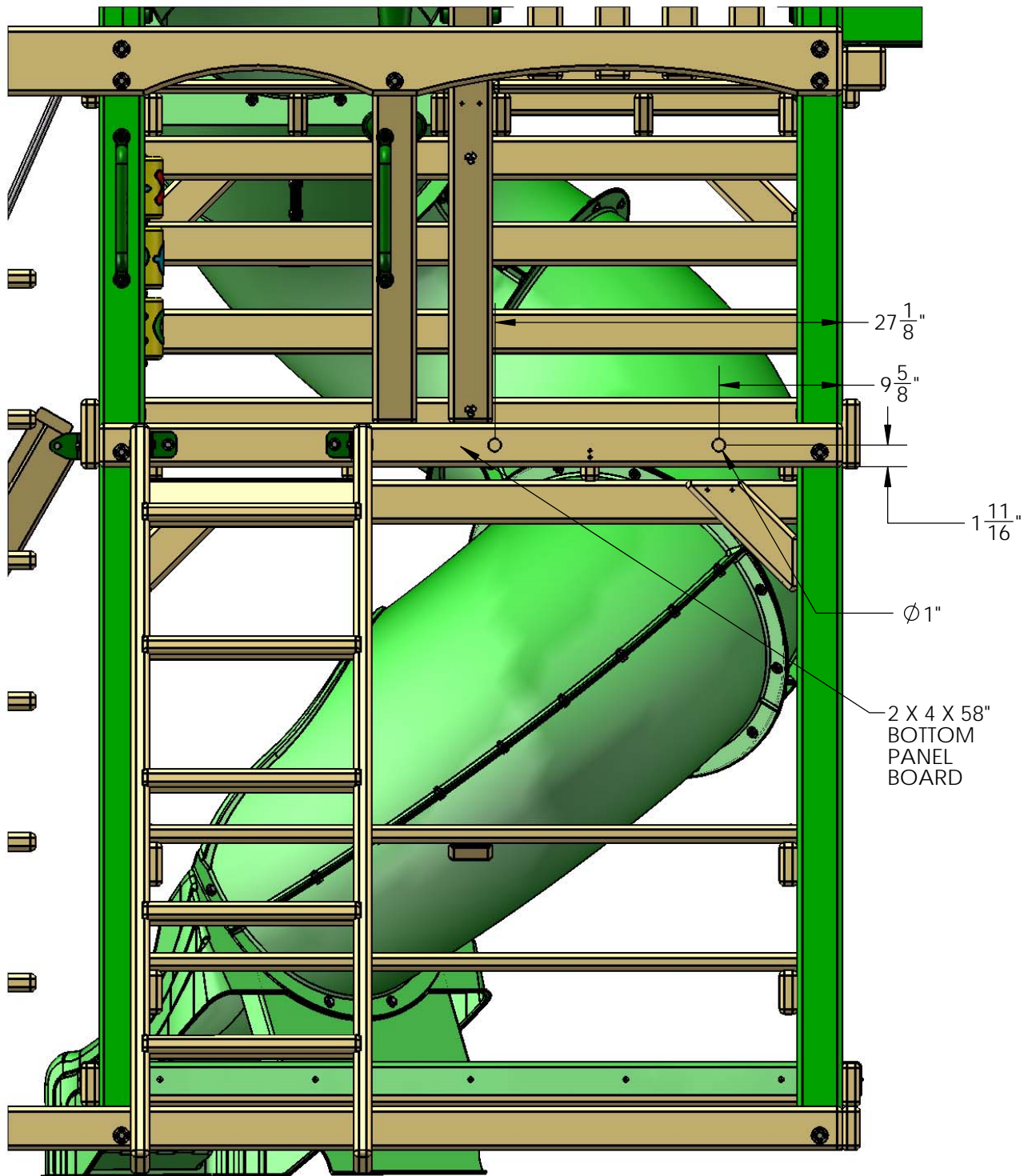

FRONT OF PLAY SET



## STEP 21A: DRILLING HOLES IN FORT

1: MEASURE AND MARK THE LOCATION SHOWN BELOW ON THE 2 X 4 X 58" LOWER DECK SUPPORT. THIS IS THE DECK SUPPORT THAT IS CLOSEST TO THE CLATTER BRIDGE SIDE OF THE PLAY SET. THE LOWER DECK SUPPORT WAS INSTALLED IN STEP 10.

2: DRILL A 1" DIAMETER HOLE IN THE DECK SUPPORT WITH A SPADE (PADDLE) BIT OR AUGER STYLE BIT.

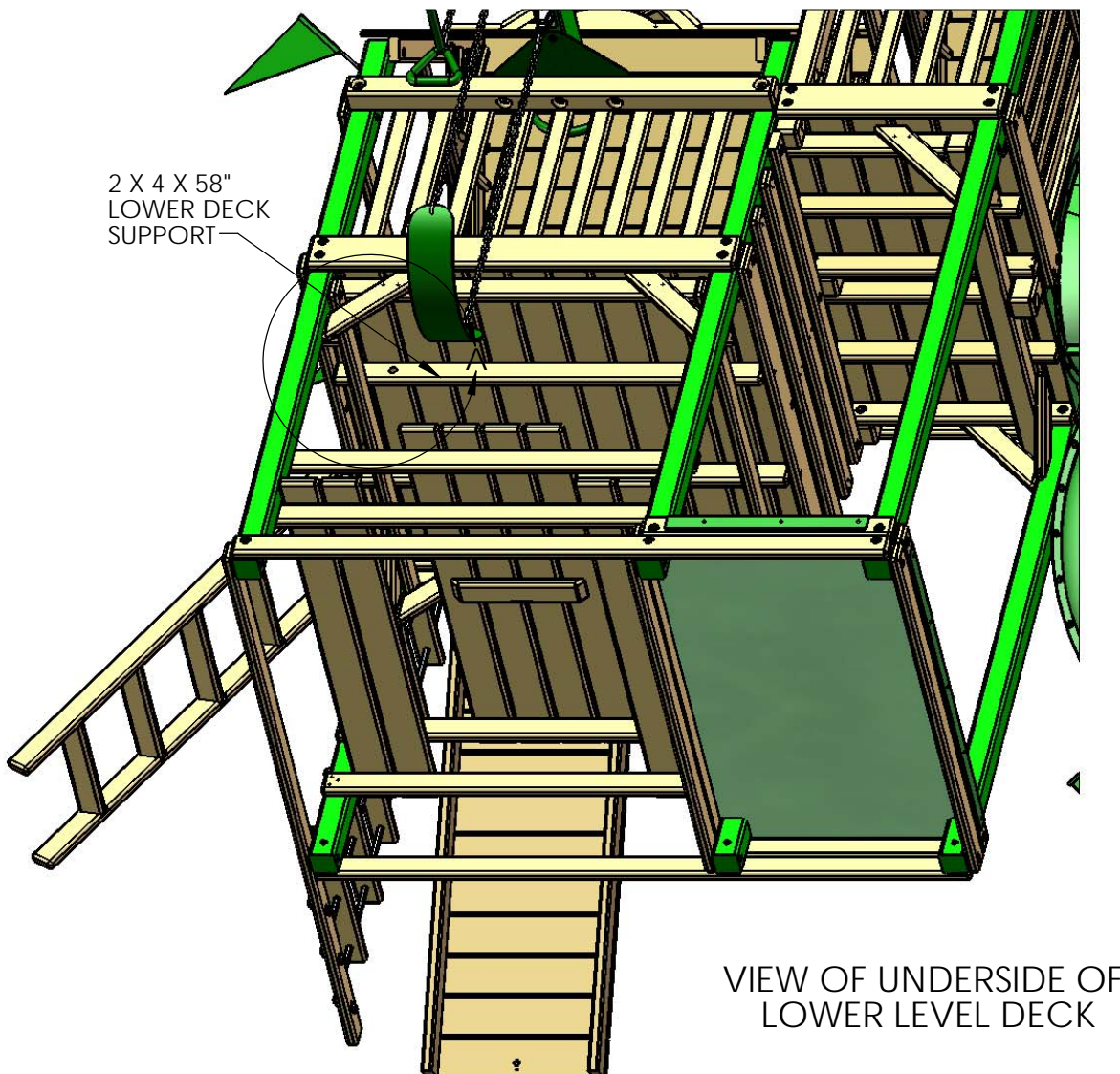
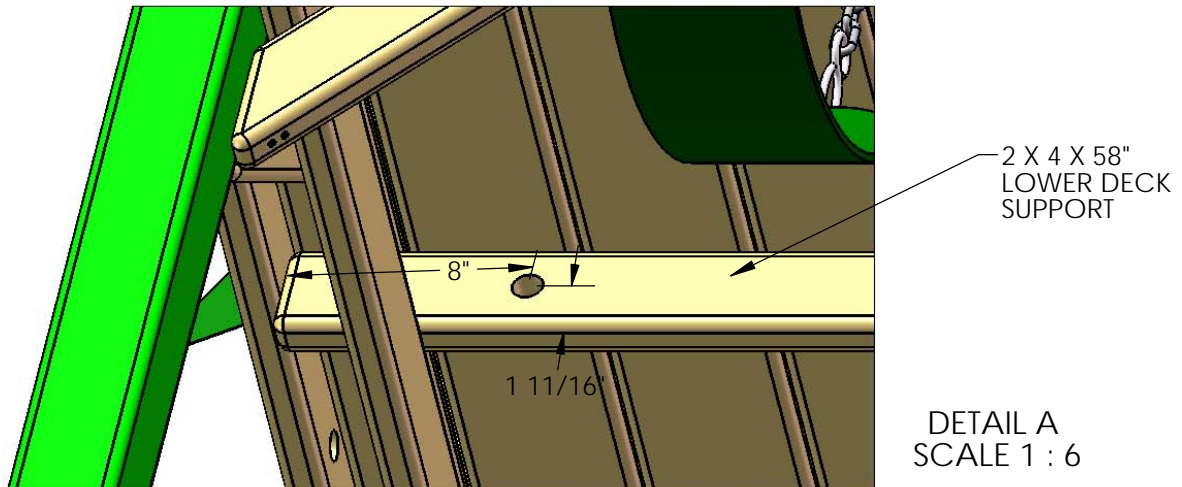

# STEP 22: BRIDGE DECK/CHAIN INSTALLATION

1: TWO PEOPLE MAY BE REQUIRED FOR THIS STEP.

2: THERE SHOULD BE AT LEAST A 1" TO 1-3/4" GAP BETWEEN THE BRIDGE DECK BOARD AND THE BOTTOM PANEL BOARD ON THE PLAY SET. THIS MEANS THAT YOU WILL HAVE TO CONNECT THE ENDS OF THE CHAINS IN A MANNER TO ACHIEVE THE CORRECT GAP. IN ORDER TO ACHIEVE THE GAP YOUR ASSISTANT MAY HAVE TO LIFT UP THE BRIDGE DECK ASSEMBLY WHILE YOU CONNECT THE CHAINS TOGETHER WITH THE QUICK LINK UNDER THE PLAY SET DECK. IF YOU HAVE LOOSE ENDS OF THE CHAINS HANGING DOWN THREAD THEM THROUGH THE QUICK LINK TO KEEP THEM UP AND OUT OF THE WAY.

3: THREAD THE CHAIN ENDS IN THE BRIDGE DECK ASSEMBLY THROUGH THE HOLES IN THE 2 X 4 X 58" BOTTOM PANEL BOARD AT THE FRONT OF THE PLAY SET. THREAD THE LEFT CHAIN THROUGH THE HOLE IN THE 2 X 4 X 58" LOWER DECK SUPPORT. CONNECT THE LEFT CHAIN TO THE RIGHT CHAIN WITH A QUICK LINK.

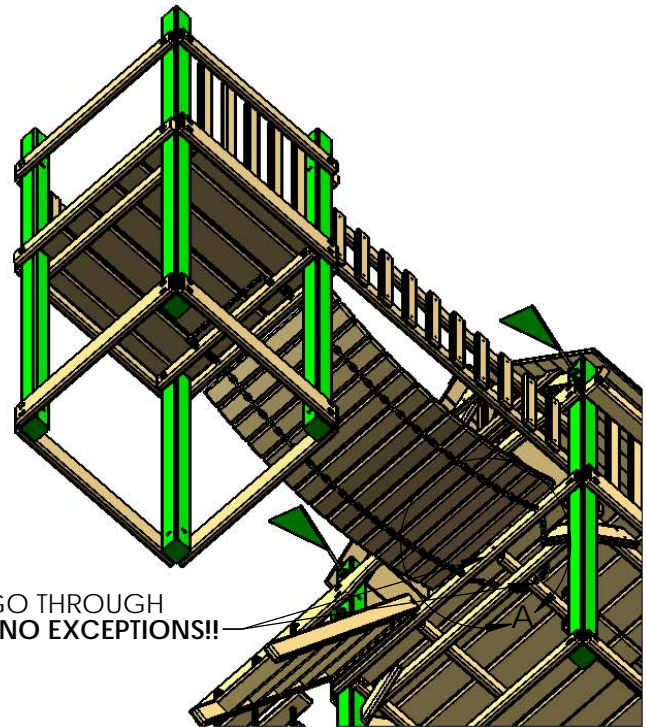
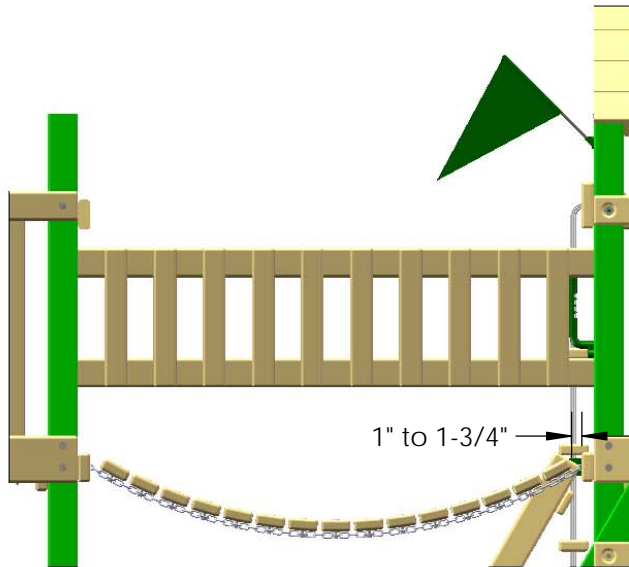

CHAIN MUST GO THROUGH TWO BOARDS **NO EXCEPTIONS!!**

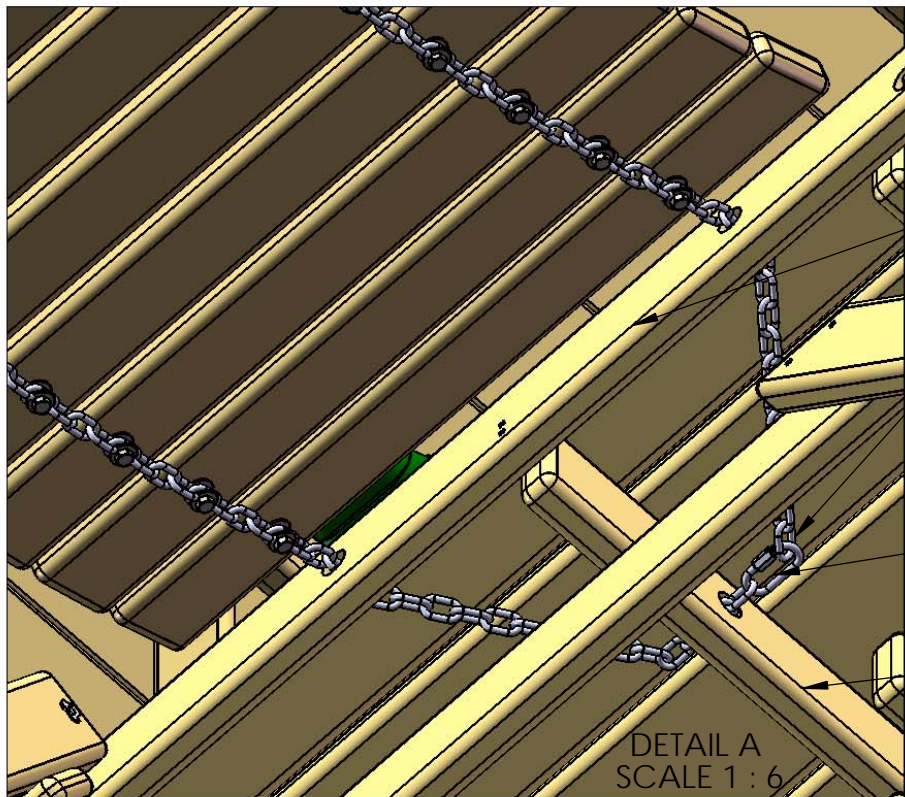

2 X 4 X 58"  
BOTTOM PANEL BOARD

NOTE: TO ACHIEVE THE CORRECT GAP YOU MAY NOT BE CONNECTING THE END LINK OF EACH CHAIN. FOR EXAMPLE YOU MAY HAVE TO CONNECT THE SECOND, THIRD, FORTH LINKS, ETC. TOGETHER.

QUICK LINK

2 X 4 X 58"  
LOWER DECK SUPPORT

DETAIL A  
SCALE 1 : 6

## STEP 23: VERTICAL TARP SUPPORTS

1: PLACE THE 2 X 4 X 33" VERTICAL TARP SUPPORTS ON THE INSIDE OF THE TOP PANEL BOARDS. THE END OF EACH VERTICAL TARP SUPPORT SHOULD BE FLUSH TO THE BOTTOM OF THE TOP PANEL BOARD. CENTER EACH VERTICAL TARP SUPPORT WITH THE CENTER OF THE TOP PANEL BOARD. SQUARE EACH VERTICAL TARP SUPPORT TO THE TOP PANEL BOARD.

2: ATTACH THE VERTICAL TARP SUPPORTS TO THE TOP PANEL BOARDS WITH 2-1/2" WOOD SCREWS.

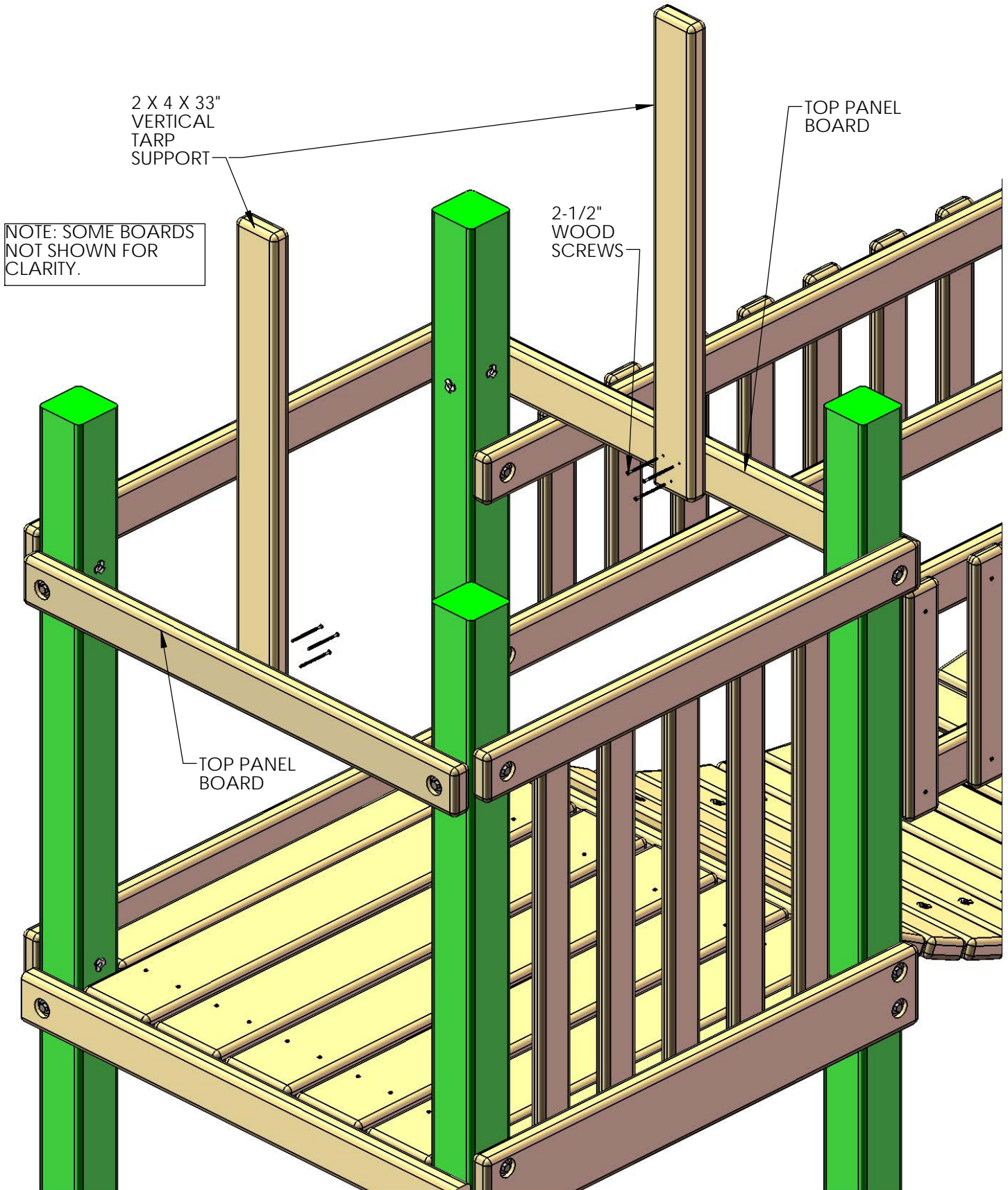

## STEP 24: TARP BOARDS

- 1: LOCATE THREE 2 X 4 X 36-3/4" TARP BOARDS.
- 2: PLACE ONE TARP BOARD ON TOP OF THE VERTICAL TARP SUPPORTS. THE END OF THE TARP BOARD SHOULD BE FLUSH WITH THE SIDES OF THE VERTICAL TARPS SUPPORTS.
- 3: ATTACH THE TARP BOARD TO THE VERTICAL TARP SUPPORTS WITH 2-1/2" WOOD SCREWS.
- 4: PLACE ONE TARP BOARD ON TOP OF THE CORNER POSTS. THE TARP BOARD SHOULD BE FLUSH TO THE OUTSIDE OF THE CORNER POST.
- 5: ATTACH THE TARP BOARD TO THE TOP OF THE CORNER POSTS WITH 2-1/2" WOOD SCREWS.
- 6: REPEAT SUBSTEPS 4 AND 5 TO INSTALL THE LAST TARP BOARD.

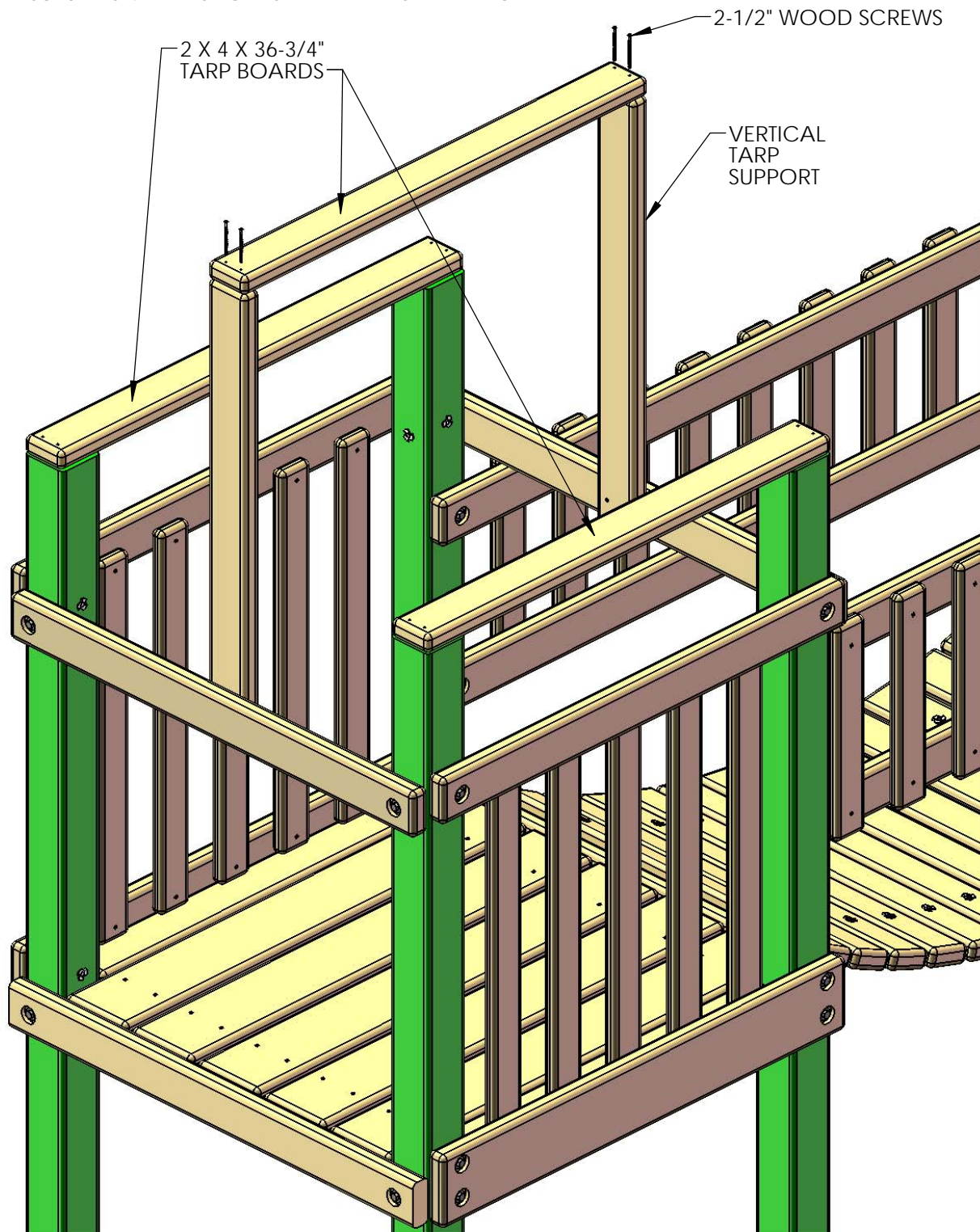

## STEP 25: CLATTER BRIDGE TARP

- 1: LOCATE THE 34-1/4" X 57-1/2" CLATTER BRIDGE TARP.
- 2: PLACE THE TARP OVER THE TOP OF THE TARP BOARD ON TOP OF THE VERTICAL TARP SUPPORTS.
- 3: THE TARP WILL OVERLAP THE SIDE OF THE TARP BOARDS ON TOP OF THE CORNER POSTS.
- 4: ATTACH THE TARP THROUGH THE GROMMETS TO THE TARP BOARDS WITH #14 X 1-1/4" PAN HEAD SCREWS AND 1/4" FLAT WASHERS.

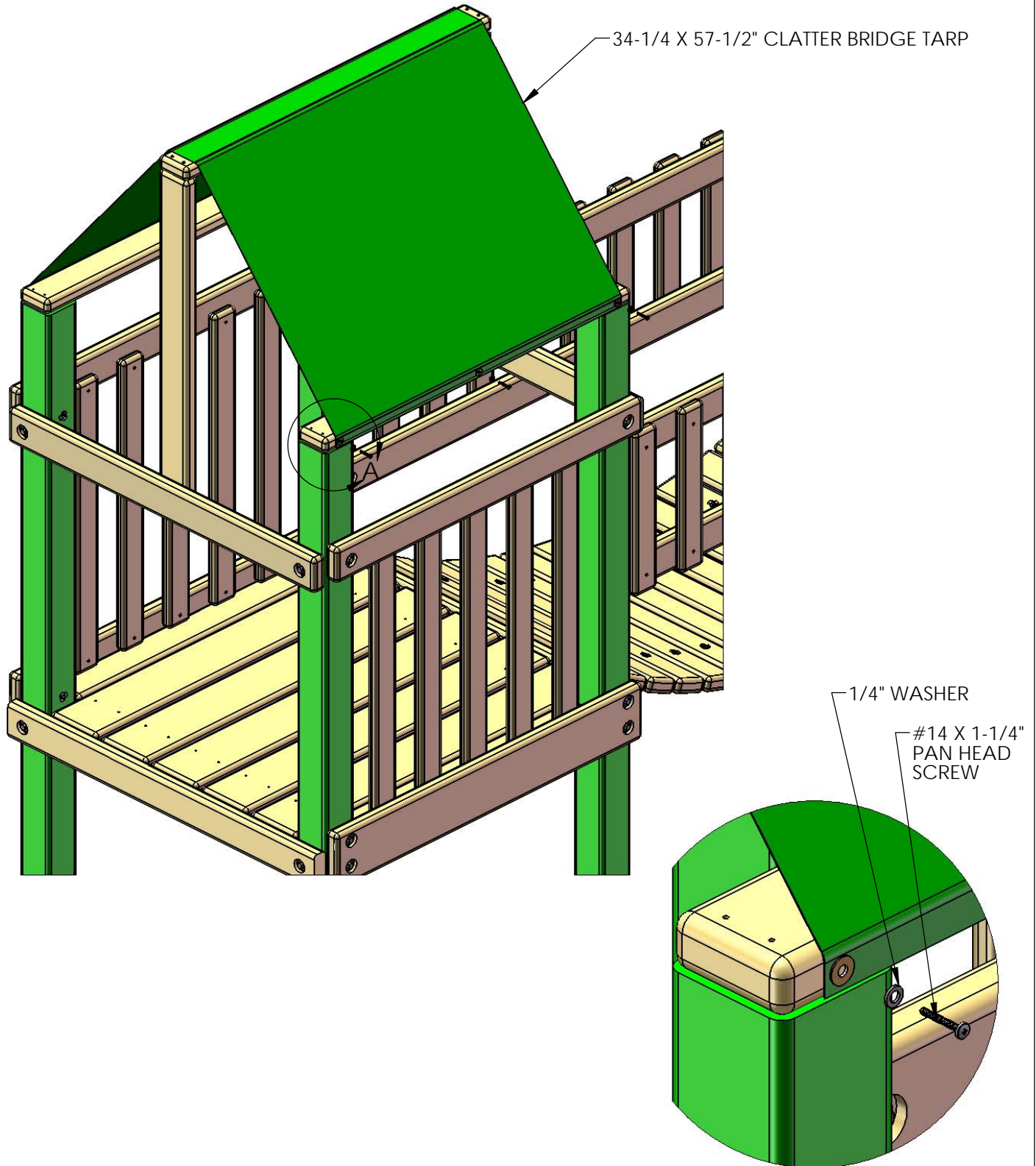

DETAIL A  
SCALE 1 : 3

## STEP 26: ATTACHING WAVE SLIDE

1: PLACE THE SLIDE IN THE OPENING OF THE CLATTER BRIDGE TOWER AS SHOWN WITH THE LIP OF THE SLIDE RESTING ON TOP OF THE DECK BOARDS.

2: ATTACH THE SLIDE TO THE DECK BOARDS WITH FOUR #14 X 1-1/4" PAN HEAD SCREWS  
**\*\*DO NOT OVERTIGHTEN\*\***

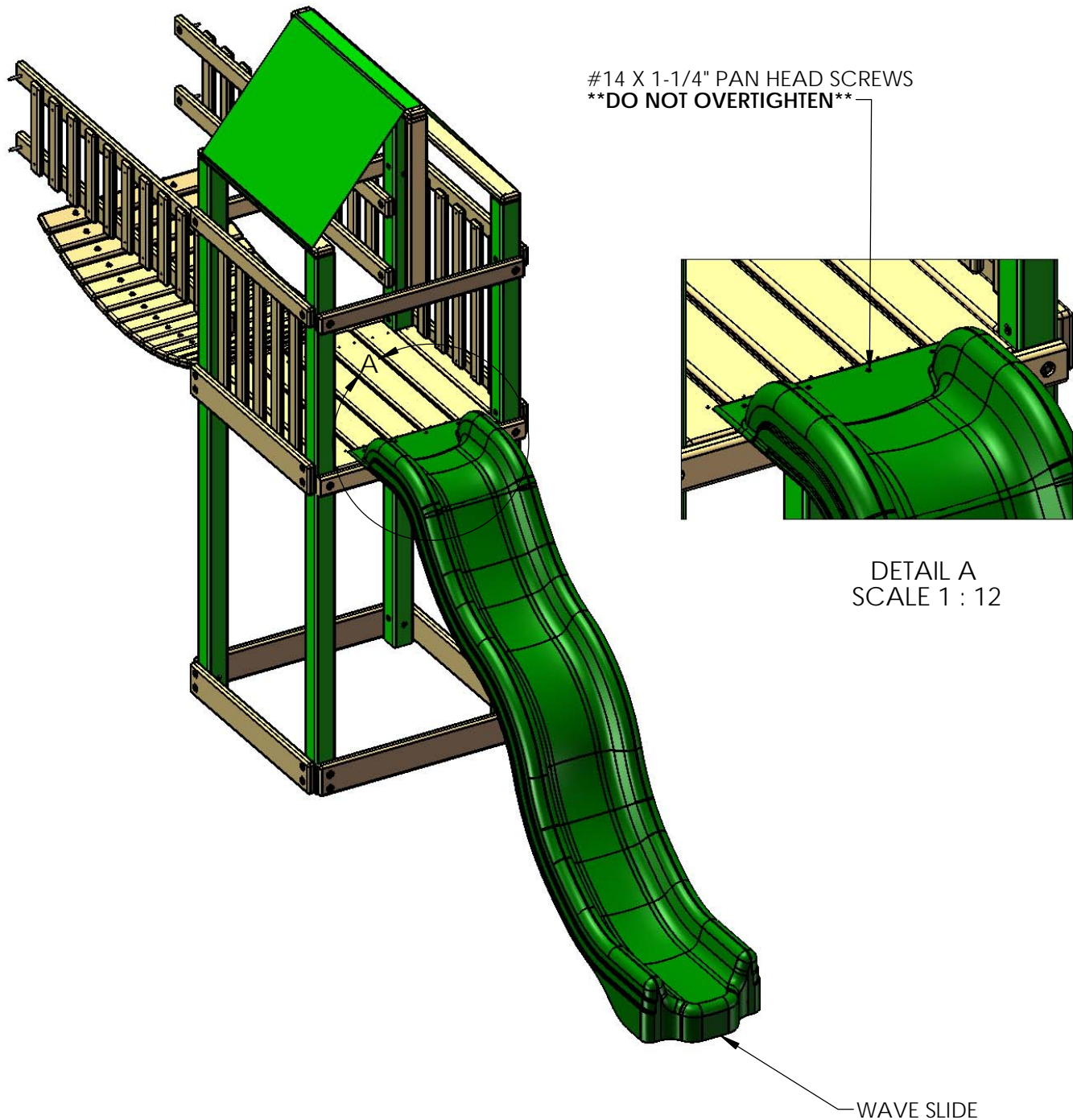

## STEP 27: TELESCOPE

1: PLACE ONE OF THE L-SHAPED TELESCOPE MOUNTING BRACKETS ON TOP OF THE 2 X 4 X 36-3/4" TOP PANEL BOARD.

2: ATTACH THE L-SHAPED BRACKET WITH TWO SCREWS PROVIDED WITH THE TELESCOPE.

3: PLACE THE BASE OF THE TELESCOPE IN THE CUT OUT AREA OF THE L-SHAPED BRACKET.

4: ATTACH ANOTHER L-SHAPED TELESCOPE MOUNTING BRACKET DIRECTLY ACROSS FROM THE PREVIOUSLY INSTALLED BRACKET AND SECURE WITH THE PROVIDED HARDWARE.

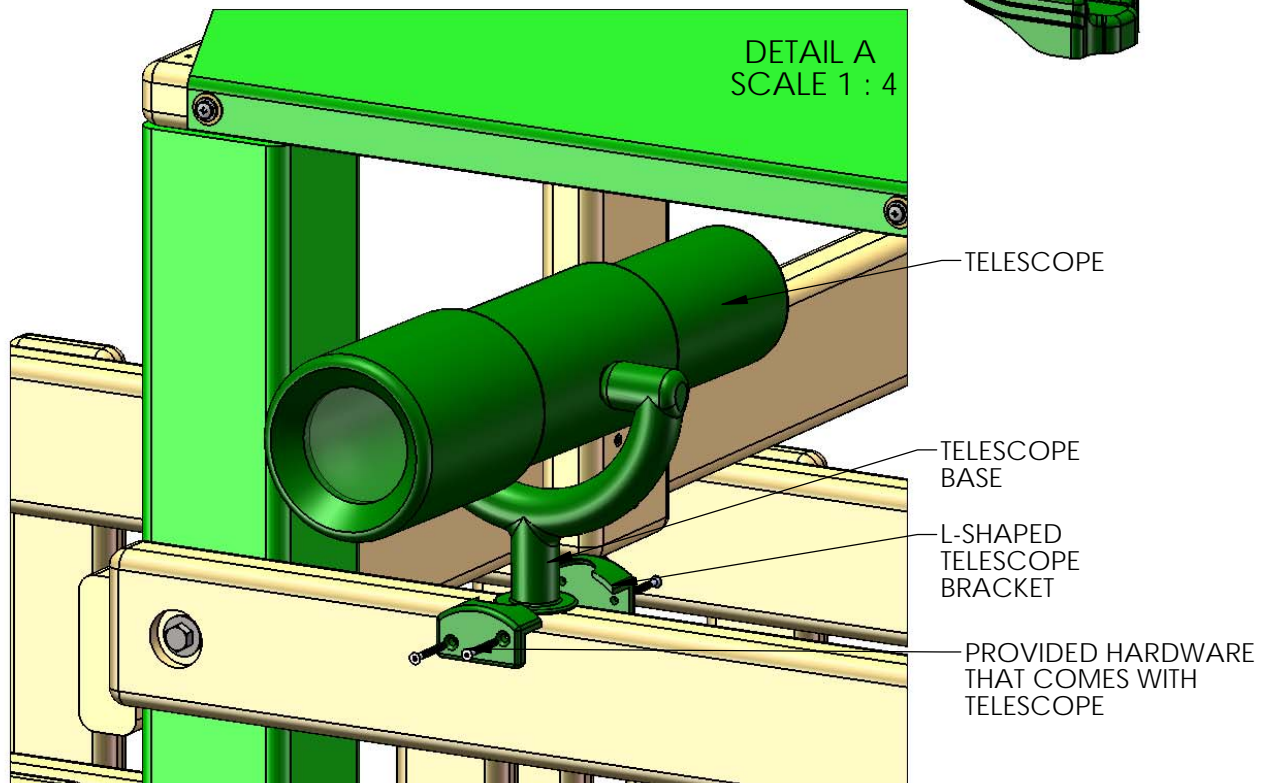
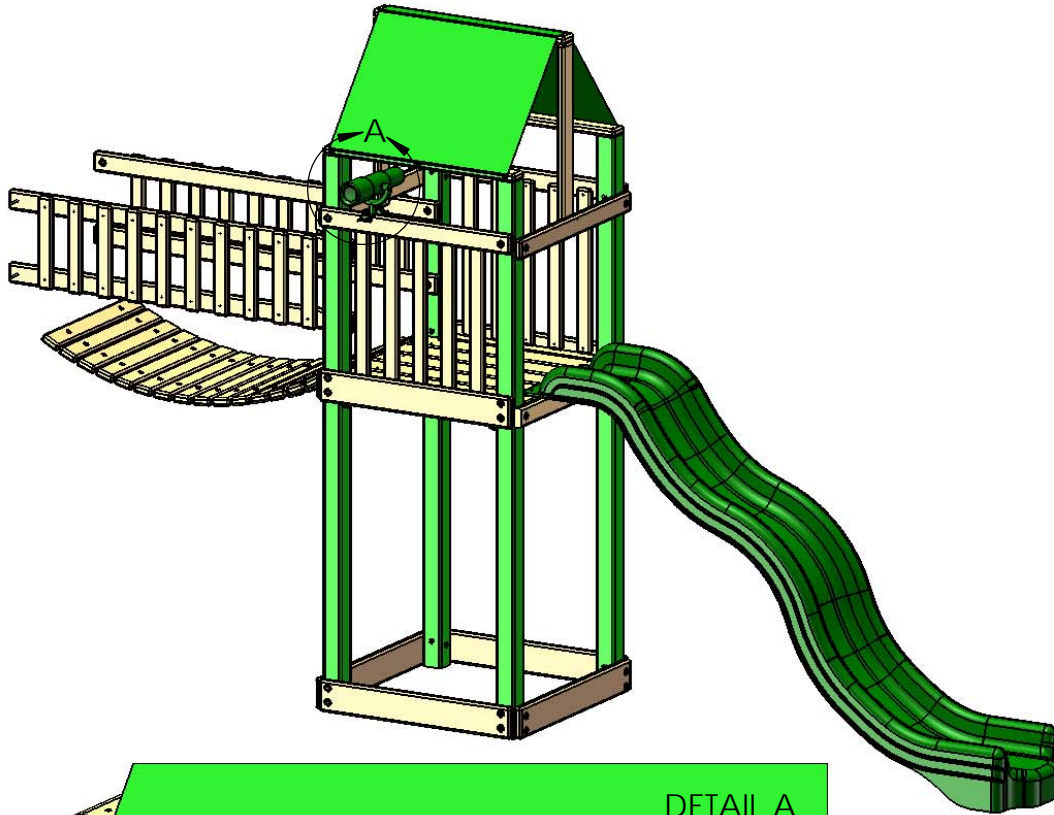

## STEP 28: NAME PLATE

1: FASTEN THE PLAY SET LOGO PLATE TO THE FRONT OF THE SWING BEAM WITH TWO 2-1/2" WOOD SCREWS.

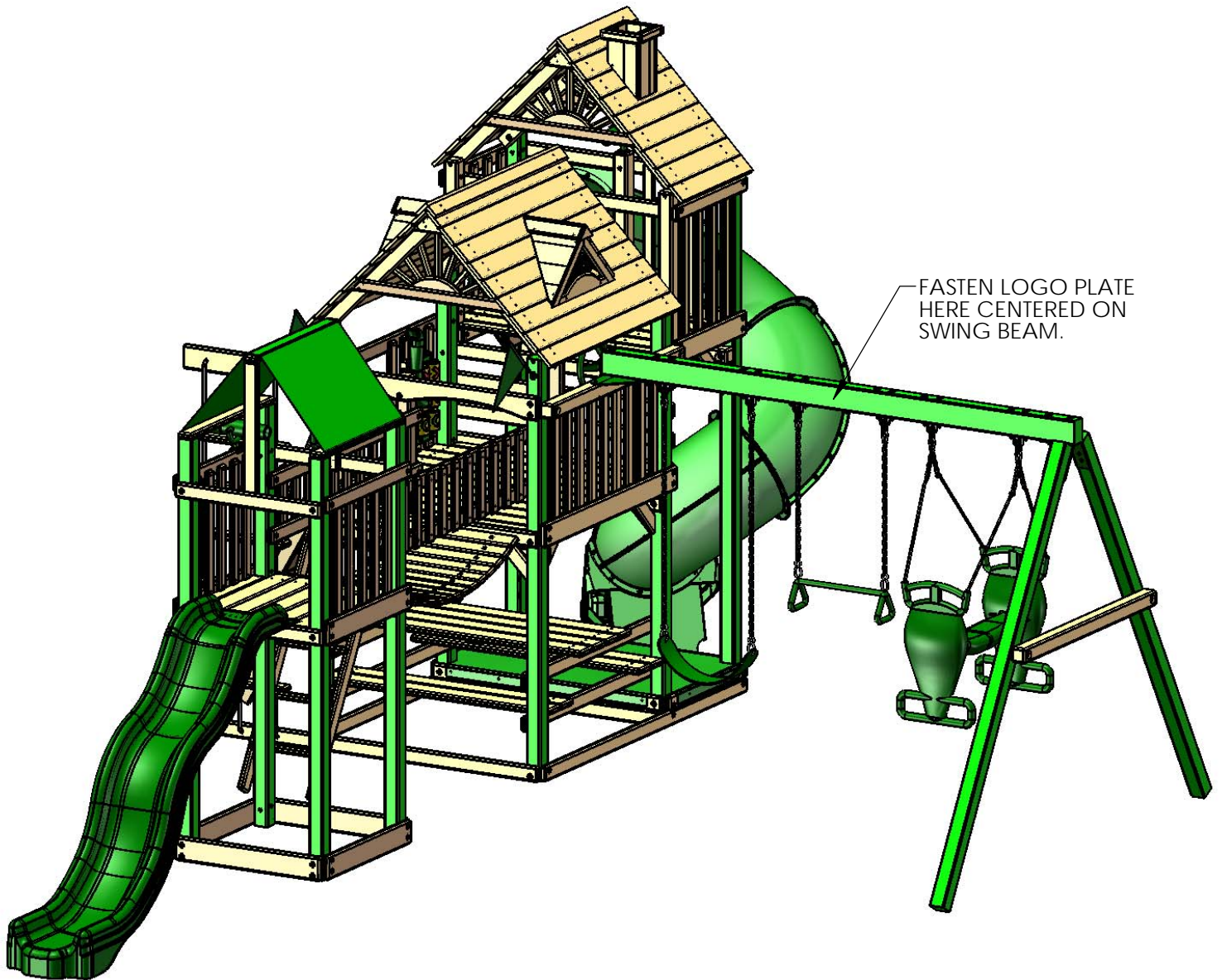



# WARRANTY REGISTRATION

- Treasure Trove -

Gorilla Playsets manufactures the finest quality products that are designed for outstanding strength and durability. We back our products with an unparalleled warranty. In the unlikely event that you will need to contact us about covered repairs, we must have a valid Warranty Registration on file.

3 EASY WAYS TO REGISTER	
OPTION 1	Fax this completed form to: <b>(678) 880-3329</b> <b>OR</b> Mail this completed form to: <b>Gorilla Playsets</b> <b>190 Etowah Industrial Court</b> <b>Canton, GA 30114</b>
OPTION 2	Complete the online registration form at: <a href="http://www.gorillaplaysets.com/register">http://www.gorillaplaysets.com/register</a>
OPTION 3	Scan this QR Code with your smart phone to complete the form using your phone 

## Where did you buy this product?:

Date of Purchase \_\_\_\_\_ Place of Purchase \_\_\_\_\_

## Your registration information:

Name: \_\_\_\_\_ Email: \_\_\_\_\_

Address: \_\_\_\_\_  
Street City State Zip

Please select your age?  18-30  31-40  41-50  51+

How old are your children?  2-3  4-5  6-7  8+

How would you rate the quality of this product?

★★★★★ Excellent

★★★★ Above Average

★★★ Average

★★ Below Average

★ Poor

Would you recommend this product to friends & family?  Yes  No

Comments: \_\_\_\_\_  
 \_\_\_\_\_  
 \_\_\_\_\_  
 \_\_\_\_\_