

gorilla

playsets



Retreat

ASSEMBLY MANUAL

Copyright © 2009 Gorilla Playsets
All Rights Reserved

Gorilla Playsets • 190 Etowah Industrial Court • Canton, GA 30114 • (800) 882-0272

8/JUN/2009 – Version 2.2.0

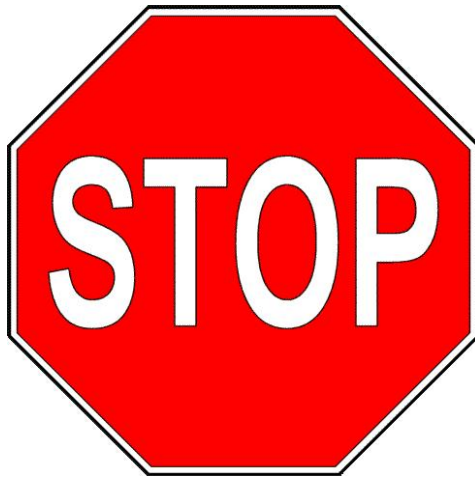

STOP...PLEASE READ!!

IF YOU HAVE MISSING OR DAMAGED PARTS OR NEED ASSISTANCE ASSEMBLING, PLEASE CALL gorilla playsets™ MANUFACTURING DIRECT.

(800) 882-0272

FACTORY HOURS – MON.–FRI., 8AM-5PM EST

DO NOT RETURN THIS PRODUCT TO THE RETAILER OR CONTACT THE RETAILER DIRECT. THE RETAILER DOES NOT STOCK COMPONENTS.

PLEASE RETAIN THESE INSTRUCTIONS FOR FUTURE REFERENCE. KEEP THEM IN A SAFE PLACE WHERE YOU CAN REFER TO THEM AS NEEDED.

CONTACT INFO:

**Gorilla Playsets
190 Etowah Industrial Court
Canton, GA 30114
Tel. (678) 880-3328
Fax. (678) 880-3329
custsrv@gorillaplaysets.com**



Blue Ridge Retreat

TABLE OF CONTENTS

Warranty and Safety Guidelines.....	4-10
Kit Contents and Tool List.....	11-30
Framing the play set.....	steps 1-6
Constructing deck.....	steps 7-10
Constructing rock wall and securing to fort.....	steps 11-15
Constructing ladder and securing to fort.....	steps 16-17
Framing the upper deck.....	steps 18-24
Constructing porch.....	steps 25-28
Constructing upper deck.....	steps 29-31
Installing panel slats.....	step 32
Swing beam construction.....	steps 33-42
Roof and sunburst construction.....	steps 43-50
Installing the picnic table.....	steps 51-53
Installing the wave slide.....	step 54
Installing safety handles.....	step 55
Installing the telescope.....	step 56
Constructing and installing the Rad Ride Slide.....	steps 57-64
Assembling and installing the Tic-Tac-Toe Panel.....	steps 65-67
Assembling and installing the chimney and dormers.....	steps 68-73
Customer registration card.....	105

**PLEASE READ OWNER'S MANUAL CAREFULLY BEFORE
STARTING ASSEMBLY!**

Thank you for choosing **gorilla playsets®** for your new backyard playground!

We've included everything you need, except tools, to build your very own professional looking playset. When complete, your new playset should far exceed the quality of playset kits from other build-your-own companies. Our engineers and design team have over 30 years of playground experience. What we've developed is a playset that doesn't compromise quality for simplicity. Yet you'll appreciate how quick and easy construction really is! Our playset kits are designed for children ages 3 to 11. **gorilla playsets®** believes every child should have a playset and with our kits they can! You can rest assured your new playset is safe, durable and designed to hold up to the elements. As parents ourselves, we know how important the security and well-being of our children is, and this shows in all of our products.

Each playset features our step-by-step 3D illustrated manual, patented powder coated swing beam bracket, heavy-duty swing belts with chains, slide(s), accessories, plus all the required hardware and pre-milled lumber.

Quality Lumber

At Gorilla Playsets, we use only the finest, hand selected lumber available. Whether you choose a playset made from our Premium Preserved Pine, Beautiful California Redwood, Western Red Cedar, or Asian Cedar you can be assured that our lumber is strong, durable, and conforms to the national standards for use in children's play equipment. It's this quality that allows us to offer a 10 year warranty on the lumber used in our play sets.

Premium Preserved Pine

Our Premium Preserved Pine is double kiln dried. We utilize this process to minimize shrinkage, warping, and cupping. Because our pine has been "pre-shrunk", the hardware used to assemble your playset will hold tight. Our preserved pine is clean, odorless, non-staining, and non-irritating to humans, animals, or plants. Gorilla's Preserved Pine uses one of the only exterior wood preservation systems that is EPA approved. Our pine lumber is preserved with a preservative system containing copper and azole compounds to protect against termite attack and fungal decay. Our Premium Preserved Pine can withstand harsh weather conditions and is effective for decades; making Gorilla Playsets the best choice in pine lumber built swing sets.

California Redwood and Western Red Cedar*

Our Beautiful California Redwood and Western Red Cedar playsets are a natural alternative to preserved lumber. California Redwood naturally resists decay caused by the environment or by insect infestation while Western Red Cedar is a preferred wood for purposes where an attractive appearance and resistance to weather is important. All California Redwood and Western Red Cedar Gorilla Playsets receive a factory stain and sealant process. To maintain this aesthetic appeal, it is recommended that you seal your redwood and cedar play set once per year.

Asian Cedar (*Cunninghamia Lanceolata*)

Our durable Asian Cedar playsets are low-maintenance, and maintain their beauty for many years. Asian Cedar has been harvested in Southeast Asia for more than 800 years, and is prized because it naturally repels pests, fungus, and rot. Asian Cedar is used indoors and out where durability is critical. Asian Cedar can be found throughout the U.S. in outdoor lawn furniture, and on children's play structures.

*Gorilla Playsets reserves the right to substitute Western Red Cedar with other species of similar characteristics due to market availability.

Limited Manufacturers Warranty

gorilla playsets® warrants this product to be free from defects in workmanship and materials, under normal use and conditions, for a period of 10 years for structural wood components and one year for all other components (i.e., hardware, plastics, tarps, rope ladder, etc.). Cosmetic defects that do not affect the structural integrity of the product, or natural defects of wood such as warping, checking or any other physical properties of wood that do not present a safety hazard, are not covered by this warranty.

gorilla playsets® will repair, or, at its discretion, replace any part within the stated warranty period that is defective in workmanship or materials. This decision is subject to verification of the defect upon delivery of the defective part to **gorilla playsets®** at 190 Etowah Industrial Court, Canton, Georgia 30114. Any part(s) returned to **gorilla playsets®** must include proof and date of purchase.

This warranty is valid only if the product is used for the purpose for which it was designed and installed at a residential, single-family dwelling. This warranty is void if the product is put to commercial or institutional use. This warranty does not cover (a) products which have been damaged by negligence, natural disasters, or accident by improper use, or which have been modified or repaired by unauthorized persons, (b) the cost of labor, or (c) the cost of shipping the product, any part, or any replacement product or part.

This warranty is valid only in the United States of America, is non-transferable and does not extend to the owners of the product subsequent to the original purchaser. **gorilla playsets®** disclaims all other representations and warranties of any kind, express, implied, statutory or otherwise, including the implied warranties of merchantability and fitness for a particular purpose. **gorilla playsets®** will not be liable for any incidental or consequential damages. Some states do not allow limitations on implied warranties or exclusion of incidental or consequential damages, so these restrictions may not be applicable to you. This warranty gives you specific legal rights. You may also have other rights that vary from state to state.

IMPORTANT SAFETY GUIDELINES

This product is intended for residential use only and not intended for use in any public setting. A safety surface such as mulch or recycled tire should be used under the play set to prevent injury from falls. Also a 6 foot safety zone should be used around the entire playset.

As with any home project, good judgment and respect for power tools will greatly reduce the risk of injury. **gorilla playsets®** recommends you follow all tool manufacturers' safety guidelines. Always wear eye protection and safety gloves to prevent injury. In several phases of construction two people may be required for lifting and securing of lumber. While playset is being constructed, please keep children off the equipment until the project is complete. Bolts and screw heads should be checked regularly for tightness. The ground ladder, rope ladder, slide, swings and other areas where children spend a majority of their playtime should be checked more frequently.

gorilla playsets® shall not be liable for incidental, indirect or consequential damages or injuries that result from the building and/or playing on our playsets. Adult supervision is recommended anytime a playset is being used.

WEIGHT LIMITS FOR GORILLA PLAYSETS

- FORT PLATFORMS: 800 LBS. TOTAL WEIGHT
- SWING BELTS: 175 LBS.
- GLIDER SWINGS: 70 LBS. PER CHILD
- TRAPEZE: 125 LBS.
- FULL BUCKET SWING: 50 LBS.
- TODDLER BUCKET SWING: 50 LBS.
- INFANT SWING: 35 LBS.
- TIRE SWING: 125 LBS. TOTAL WEIGHT
- ROPE LADDER: 75 LBS.
- ROCK WALL: 150 LBS.
- ALL SLIDES: 125 LBS.

Gorilla Playsets recommends that the weight limits for all components must not be exceeded. Failure to adhere to these and other safety guidelines could result in damage to the playset and injury to the users.

Safety and Maintenance Tips for Your New Play Set:

NOTE: Your children's safety is our #1 concern. Observing the following statements and warnings reduces the likelihood of serious or fatal injury. Please review these safety rules regularly with your children.

- This playset is designed for the use of 4 occupants who have a combined weight **not exceeding** 800 pounds on the elevated floor, 3 occupants who have a combined weight of 525 pounds on the swing area, for a total Unit capacity of 5 occupants who have a combined weight of 1325. (this weight is not including the picnic table area)
- On-site adult supervision is **required**.
- Teach children **not** to walk close to, in front of, behind, or between moving swings or other moving playground equipment.
- Teach children to sit in and **never** stand on swings
- Teach children **not** to twist the chains and ropes and not to loop them over the swing beam, since this may reduce the strength of the chain or rope.
- Teach children **not** to jump from swings or other playground equipment in motion.
- Teach children to **not push** empty seats. The seat may hit them and cause serious injury.
- Teach children to sit in the center of the swings with their full weight on the seats.
- Teach children **not** to use the equipment in a manner other than intended.
- Teach children to **always** go down slides feet first. Never slide headfirst.
- Teach children to **look** before they slide to make sure no one is at the bottom.
- Teach children to **never** run up a slide, as this increases their chances of falling.
- The parents should have the children **dress appropriately** with well-fitting shoes. Loose clothing such as scarves and ponchos should not be worn. Always take off, tie up or tuck in cords and drawstrings on children's clothing. These things can get caught on playground equipment and strangle a child.
- Teach children **not** to climb when the equipment is wet.
- Teach children to **never** jump from a fort deck. They should always use the ladder, ramp or slide.
- Teach children to **never** crawl or walk across the top of monkey bars.
- Teach children to **never** crawl on top of a fort roof.
- Verify that any suspended climbing ropes, chains, or cables are secured at both ends and that they cannot be looped around an adult hand.
- Teach children **not** to attach items to the playground equipment that are not specifically designed for use with the equipment, such as, but not limited to, jump ropes, clothesline, pet leashes, cables and chain as they may cause a strangulation hazard.
- Teach children to **never** use Monkey Bar when swings or glider are installed.
- Teach children to **never** wrap their legs around swing chain.
- Teach children to **never** slide down the swing chain.

WARNING: Children must NOT use this playset until unit has been completely assembled and inspected by an adult to insure set has been properly installed and anchored.

Safety and Maintenance Tips for Your New Play Set: (continued)

Playgrounds should be inspected on a regular basis. If any of the following conditions are noted, they should be removed, corrected, or repaired immediately to prevent injuries.

- Hardware that is loose, worn or that has protrusions or projections
- Exposed equipment footings
- Scattered debris, litter, rocks, or tree roots
- Splinters, large cracks, and decayed wood components.
- Deterioration and corrosion on structural components, which connect to the ground
- Missing or damaged equipment components, such as handholds, guardrails, swing seats.
- Check all nuts and bolts frequently during the usage season and tighten as required. (But not so tight that you crack the wood) We recommend you check the swing beam and hardware often due to wood expansion and contraction. It is particularly important that this procedure be followed at the beginning of each season.
- Remove plastic swing seats and take indoors or do not use when the temperature drops below 32°F.
- Oil all metallic moving parts monthly during the usage period.
- Check all coverings for bolts and sharp edges twice monthly during usage season to be certain they are in place. Replace when necessary. It is especially important to do this at the beginning of each new season.
- Check swing seats, ropes, cables and chains monthly during usage season for evidence of deterioration. Replacement should be made of any swing seat that has developed cracks in the plastic seats or has exposed metal in the edges of the swing seat. If there are already exposed metal inserts on the edge of the seat, immediately remove the seats and chains to prevent serious injury. Ropes, cables and chains should be removed and replaced if excessive wear is found. Contact Gorilla Playsets for warranted replacement parts.
- For rusted areas on metallic members such as monkey bars, hand supports brackets, etc.; sand and repaint, using a non lead-based paint meeting the requirements of Title 16 CRF Part 1303.
- Inspect wood parts monthly. The grain of the wood sometimes will lift in the dry season causing splinters to appear. Light sanding may be necessary to maintain a safe playing environment. If you are treating your playset with stain regularly, it will help prevent severe checking/splitting and other weather damage.
- Once or twice a year, depending on your climate conditions, you must apply some type of protection (sealant) to the wood of your unit. Prior to the application of sealant, lightly sand any "rough" spots on your set. Please note this is a requirement of your warranty.
- Creating and maintaining the playset on a level location is very important. As your children play, your playset will slowly dig its way into the soil, and it is very important that it settles evenly. Make sure the play set is level and true once each year or at the beginning of each play season.
- Rake the surface periodically to prevent compaction and maintain appropriate depths.

Disposal Instructions: When the playset use is no longer desired, it should be disassembled and disposed of in such way that no unreasonable hazards will exist at the time the unit is discarded.

Play Set Surfacing Recommendations:

Below are some of the recommendations that the U.S. Consumer Product Safety Commission (CPSC) offers from its *Handbook for Public Playground Safety*. The guide can be downloaded in full at www.cpsc.gov/cpsc/pub/pubs/325.pdf

1. Protective Surfacing - Since almost 60% of all injuries are caused by falls to the ground, protective surfacing under and around all playground equipment is the most critical safety factor on playgrounds.

Certain manufactured synthetic surfaces also are acceptable; however, test data on shock absorbing performance should be requested from the manufacturer.

Asphalt and concrete are unacceptable. They do not have any shock absorbing properties. Similarly, grass and turf should not be used. Their ability to absorb shock during a fall can be reduced considerably through wear and environmental conditions.

Certain loose-fill surfacing materials are acceptable. Surfacing materials are acceptable, such as the types and depths shown in the table.

Fall Heights and Materials

Material	Uncompressed Depth			Compressed Depth to 9" (228mm)
	6" (152mm)	9" (228mm)	12" (304mm)	
Wood Chips	7' (2.13m)	10' (3.05m)	11' (3.35m)	10' (3.05m)
Double-Shredded bark mulch	6' (1.83m)	10' (3.05m)	11' (3.35m)	7' (2.13m)
Engineered Wood Fibers	6' (1.83m)	7' (2.13m)	>12' (3.66m)	6' (1.83m)
Fine Sand	5' (1.52m)	5' (1.52m)	9' (2.74m)	5' (1.52m)
Coarse Sand	5' (1.52m)	5' (1.52m)	6' (1.83m)	4' (1.22m)
Fine Gravel	5' (1.52m)	7' (2.13m)	10' (3.05m)	6' (1.83m)
Medium Gravel	5' (1.52m)	5' (1.52m)	6' (1.83m)	5' (1.52m)
Shredded Tires*	10-12' (3.0-3.6m)	N/A	N/A	N/A

*This data is from tests conducted by independent testing laboratories on a 6-inch depth of uncompressed shredded tire samples produced by four manufacturers. The tests reported critical heights, which varied from 10 feet to greater than 12 feet. It is recommended that persons seeking to install shredded tires as a protective surface request test data from the supplier showing the critical height of the material when it was tested in accordance with ASTM F1292.

It should be recognized that all injuries due to falls cannot be prevented no matter what surfacing material is used.

2. Fall Zones - A fall zone, covered with a protective surfacing material, is essential under and around equipment where a child might fall. This area should be free of other equipment and obstacles onto which a child might fall. Stationary climbing equipment and slides should have a fall zone extending a Minimum of 6' in all directions from the perimeter of the equipment.

Swings should have a fall zone extending a minimum of 6' from the outer edge of the support structure on each side. The fall zone in front and back of the swing should extend out a minimum distance of twice the height of the swing as measured from the ground to the top of the swing support structure.

LEVELING YOUR FORT DURING ASSEMBLY

- Complete the steps which will be the basic frame of the fort {i.e. four corner posts with base (sand box boards) and deck supports}
- Position in the most level area chosen for the playset, keeping in mind the location and size of the swing beam, ladder, slides, etc. that extend off the fort.
- Once the frame is in the final position, check for vertical and horizontal levelness to determine which side(s) will need to be dug into the ground to level the play set.
- With a shovel, score the ground around the outside edges of the sandbox boards on the 'high' side of the fort. This is the area that will be dug in. Make sure to score deep enough; the scored lines will be your digging template.
- Push the frame off and away from the scored area, far enough to dig and remove dirt to reach the appropriate depth.
- Dig a channel along the scored line(s) for the base of the fort (corner post and sandbox boards) to rest into. Dig the channel(s) to the same level depth. The bottom of the channel(s) should be level to each other so your frame doesn't teeter or rock because the channel(s) are uneven.
- Once you have removed enough grass and dirt, slide/push the frame into the channel(s). Place a level on the vertical and horizontal boards of the frame to determine if enough soil, or too much, was removed.
- Repeat this process until the basic frame is plumb and level and in its final position before completing the rest of the assembly.
- Measure to make sure fort is square.

Important: if you require a channel depth of more than 6", then we recommend you have your play set area professionally graded before completing assembly.

Example play area:

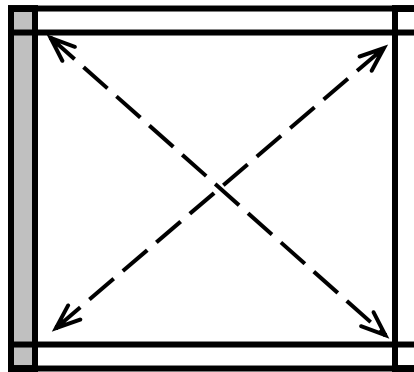
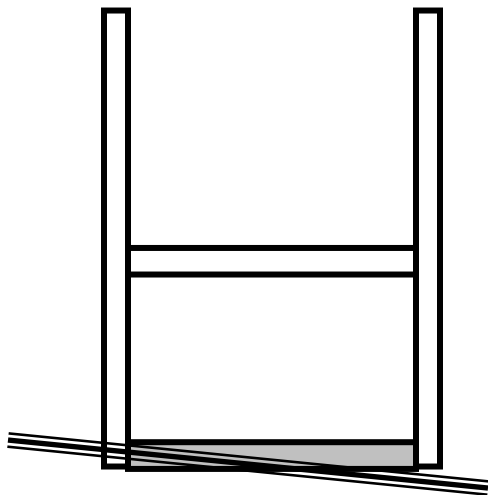

THE DIAGONAL MEASUREMENTS SHOULD BE THE SAME FROM CORNER POST TO CORNER POST. IF NOT, ADJUST FORT SO THAT THE DISTANCE IS EQUAL.

 = AREA TO BE SCORED AND CHANNIELED FOR LEVELNESS

Blue Ridge Retreat

KIT CONTENTS

COMPONENTS

Description	Qty	Check List
(Swings, Slides, Accessories)		
Swingbelts w/ Chains	2	_____
10ft. Radical Wave Slide	1	_____
Rad Ride Slide	1	_____
Trapeze Swing	1	_____
Glider Swing	1	_____
Telescope	1	_____
Safety Handles	2	_____
Tic-Tac-Toe Panel	1	_____
Chimney	1	_____
Dormer	2	_____
Retreat Assembly Manual	1	_____

Description
(Fort Hardware) *see following pages*

Description
(Swing Beam Hardware) *see following pages*

Description
(Wood Components) *see following pages*

REQUIRED TOOL LIST

- Standard or Cordless Drill w/ Phillips Bit (#2 square bit provided)
- Extension Cord (if using standard drill)
- Locking Pliers (Vise Grips, For Carriage Bolts)
- 1/8" Drill Bit Level
- 3/8" Drill Bit Tape Measure
- 7/8" Paddle Bit Hammer
- 1/2" Wrench and Socket Pencil
- 1/2" Deep Well Socket Shovel
- 9/16" Deep Well Socket Rubber Mallet
- 9/16" Wrench and Socket

Please familiarize yourself with the manual, parts/components and general construction process of your new playset before getting started.

SITE PLAN:

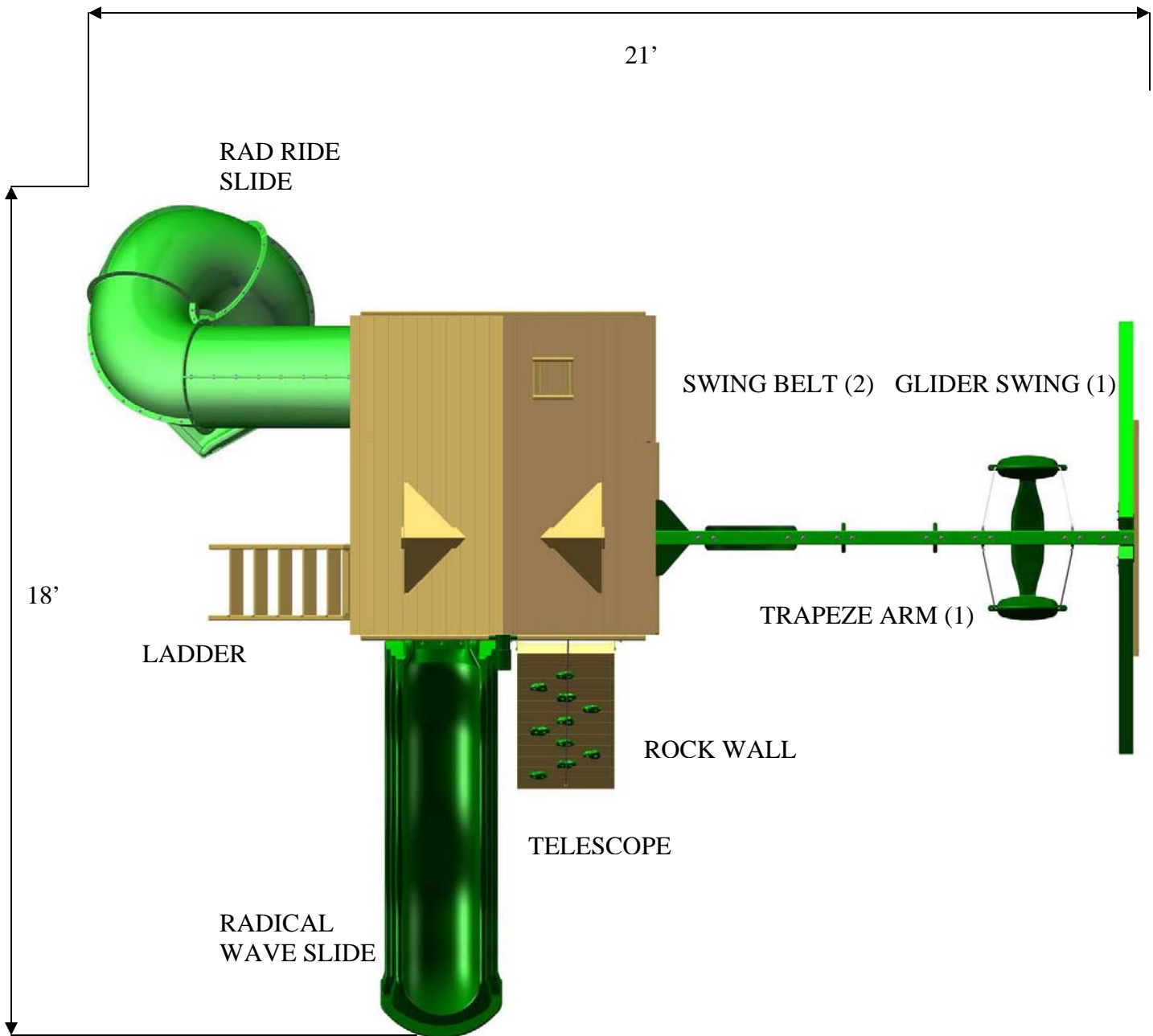

Playset height: 13' 6"

Approximate assembly time:

16-18 Hours

{ 6 foot unobstructed safety perimeter around playset recommended }

Helpful Installation Hints

- Depending on your experience, assembly of Gorilla playsets can take as little as 6 hours up to 24 hours, depending on size, after inventory of parts; therefore, we recommend you set aside a full two days for assembly.
- Identify all of the parts for your playset. Empty each box and lay out boards so you can see each part. Your instruction book will have detailed drawings that will make it easy for you to recognize individual parts. Keep all hardware and metal parts separate from wooden pieces.
- After everything is laid out, check carefully to ensure all parts are present. Make sure there are no broken boards.
- Find an area to sort your hardware. It is best to open the hardware on a solid surface so that you do not lose any pieces in the grass. This will save time and familiarize you with all the different pieces in the hardware bag.
- Important note: Wood has some natural defects such as knots, surface cracks, etc... We reject parts that are structurally defective. We use a high quality lumber in our structures; however, you should inspect each part for splinters or rough spots and sand them smooth to prevent injury.
- After familiarizing yourself with all of the components, read all instructions thoroughly. Reading instructions after you have studied the parts will help you understand more clearly the installation process, and help to eliminate unnecessary mistakes.
- Pay close attention to the diameter and length of each bolt and screw.
- Never tighten hardware completely at first. It helps to have some adjustment for bolt alignment while you are attaching parts together. After everything is square, tighten each joint.
- After the main unit is assembled it is critical that the floor is **level** and **square**. If the main frame is not level, the walls and floor will be out of square.
- After you complete installation, make sure every bolt, screw, and nut is tight, and every board is secure. Wood will expand and contract with the seasons.
- Check all bolt connections and swing hangers FREQUENTLY.
- Place the set on level ground, not less than 6ft from any structure or obstruction such as a fence, garage, house, overhanging branches, laundry lines, or electrical wires.

READ! VERY IMPORTANT!

If you are missing parts or have questions regarding the installation of our quality product PLEASE call us directly at the factory **(1-800-882-0272)**. Our trained staff will be happy to assist you.

Customer service hours:

Monday thru Friday 8AM – 5PM EST

E-mail: custsrv@gorillaplaysets.com

General Info To Review Before Installation

This page is a list of definitions and explanations used throughout our instructions to aid you in the assembly of your playset.

Offset Holes- Throughout the installation procedures we will refer to parts with offset holes. This refers to the orientation of the holes on the board. An offset hole is one that is closer to one side than it is the other or in other words, it is not centered on the board. In the procedures you will be instructed to attach the boards with the holes offset up or with the holes offset down. This refers to which side of the board the hole/holes should be closer to. Offset holes up= hole/holes will be closer to the top of the board. Offset holes down= hole/holes will be closer to the bottom of the board. Note: some parts do not have offset holes, but instead the holes are on center. Therefore there will not be any reference to how to offset these parts.

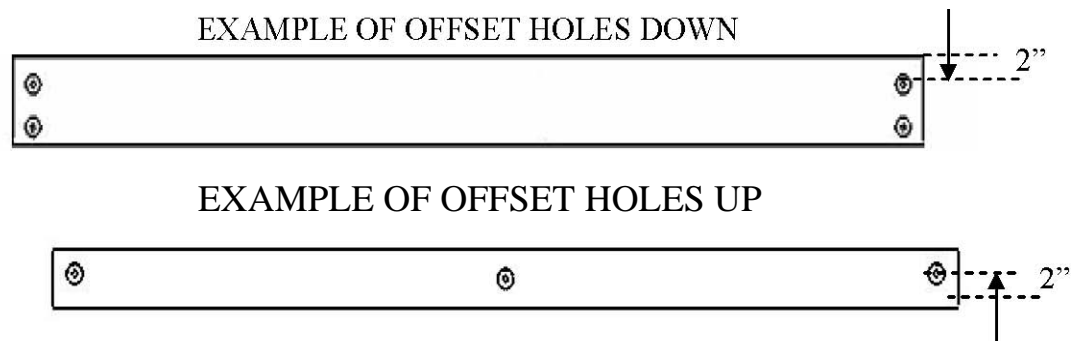

Counter-sunk holes- Many of the parts that will be used have counter-sunk holes. A counter-sunk hole is one that surrounds one side of a thru hole, but does not extend through the wood it's self. When using a counter-sunk hole the bolt will be inserted through the thru hole and either the head of the bolt and washer or nut and washer will occupy the counter sunk hole.

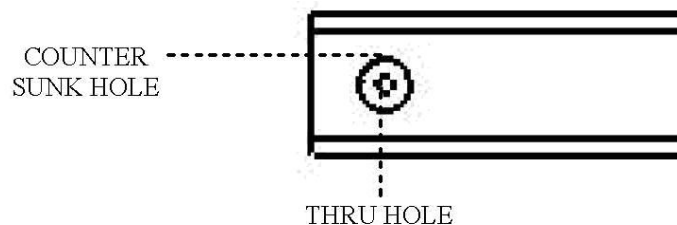

Lag Screws- Lag screws are used in the construction of our playsets to enhance the structural integrity of the unit. There will not be predrilled holes in the post for lag screw installation. Lag screws are self-tapping, though if you are using a manual socket wrench it may be necessary to tap the head of the lag screw with a hammer. You should also be sure to tighten the lags completely. Power tools such as an impact wrench or power drill should have enough torque to drive the lag screws without using a hammer, but make sure not to over tighten as this can cause the threads to "strip out" in the post.

Common installation practice
Installing T-nuts

When installing T-nuts into the wood, use a smooth faced hammer to set the face of the T-nut flush into the wood.

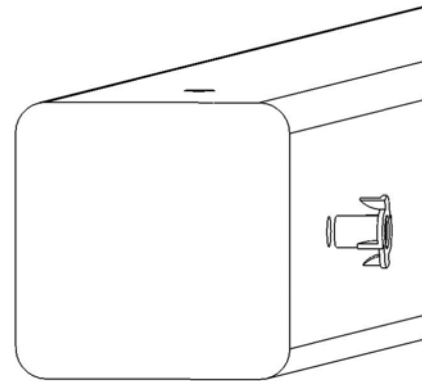
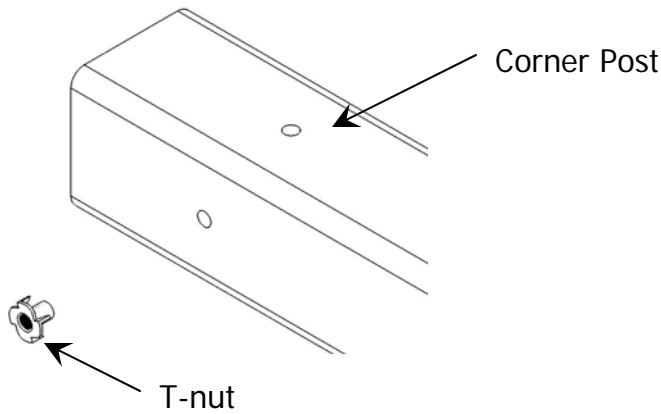

Insert the barrel of the T-nut into the predrilled hole. Using a smooth faced hammer, drive the T-nut until the face of the T-nut is flush to the wood.

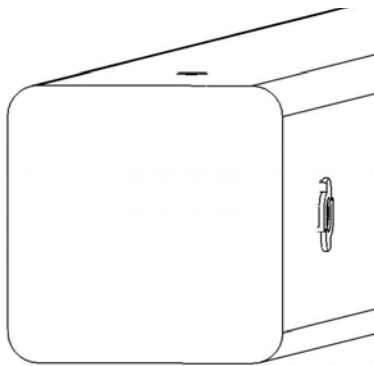

This picture shows the T-nut insert and installed flush to the wood.

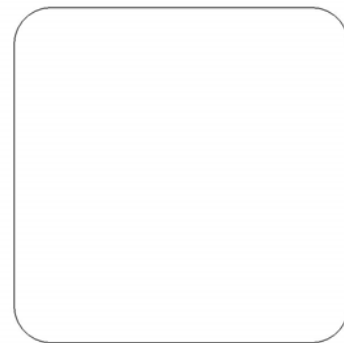

This picture shows an end view of the T-nut insert and installed flush to the wood.
WARNING: DO NOT EMBED THE TOP OF THE T-NUT INTO THE FACE OF THE WOOD

Cross Section end views, you are looking at an X-ray view of the post and T-nut. The barrel of the T-nut is in the corner post the line is the face of the wood.

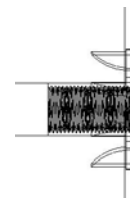

Flush
Correct



#14 X 1-1/4"
PAN HEAD SCREW
QTY: 40

#8 X 1-1/4"
WOOD SCREW
QTY: 2



#8 X 1-1/2"
WOOD SCREW
QTY: 350



#8 X 2"
WOOD SCREW
QTY: 240



#8 X 2-1/2"
WOOD SCREW
QTY: 65



1/4" WASHER
QTY: 40

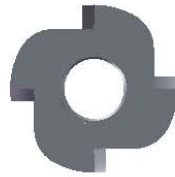

5/16" TEE NUT
QTY: 60



5/16" LOCK NUT
QTY: 107



3/8" LOCK NUT
QTY: 22

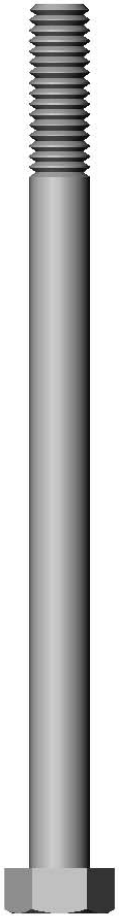

5/16 X 4-1/2"
HEX BOLT
QTY: 54



5/16 X 1-1/2"
HEX BOLT
QTY: 8



5/16 X 3/4"
HEX BOLT
QTY: 107

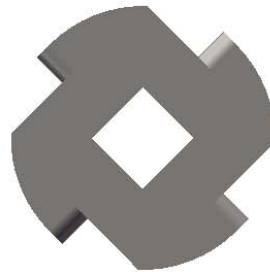

TORQUE WASHER
QTY: 18



1/2" WASHER
QTY: 2

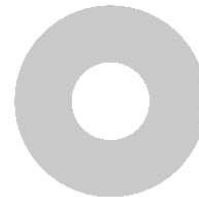

3/8" WASHER
QTY: 45



5/16" WASHER
QTY: 345

9

8

7

6

5

4

3

2

1

USE THE RULER TO THE RIGHT TO MEASURE YOUR BOLTS AND SCREWS. PICTURE VIEWS SHOWN ABOVE ARE 1:1 SCALE AND CAN BE USED TO MATCH BOLT AND SCREW SIZES.

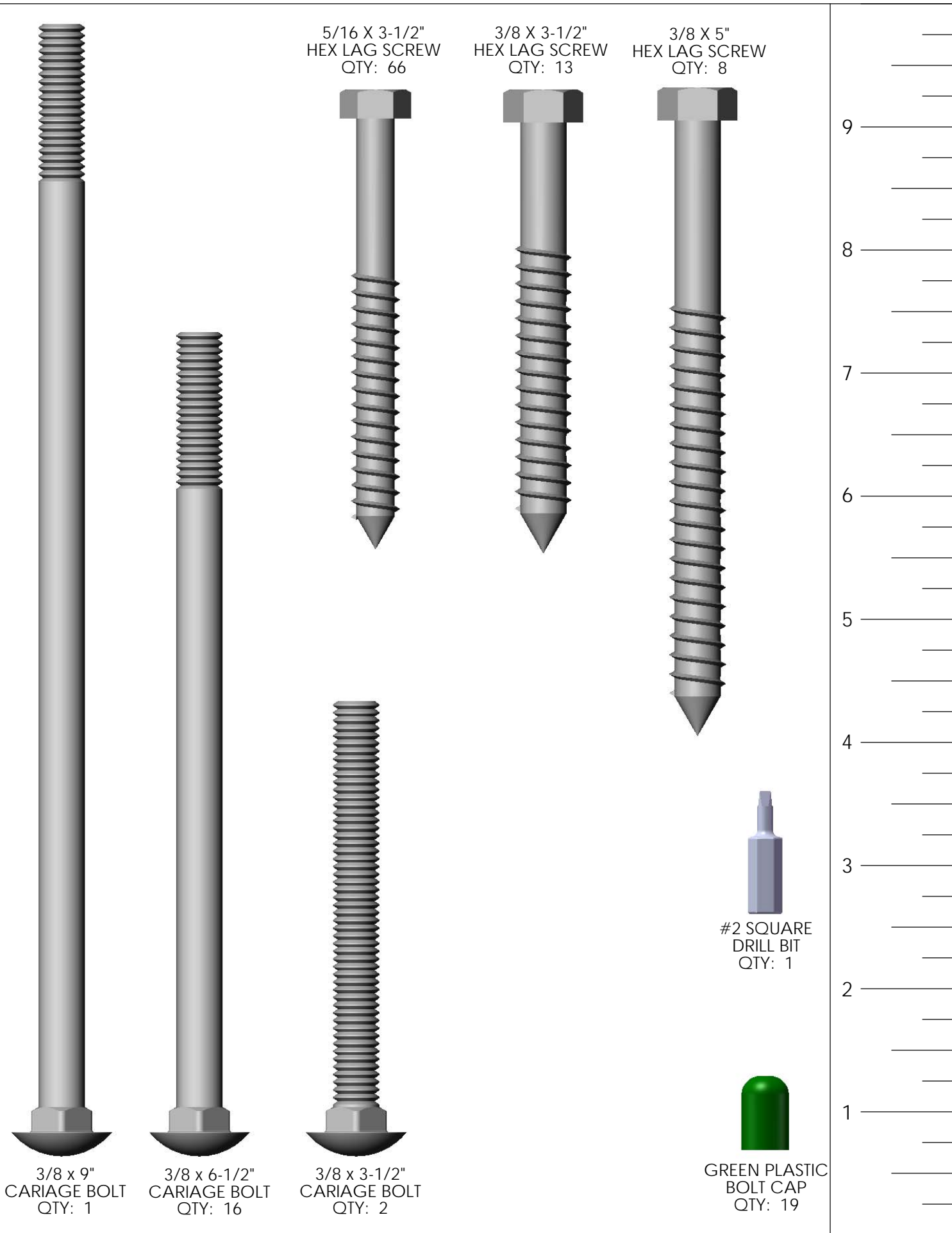



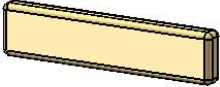
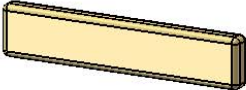
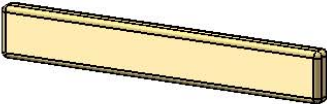
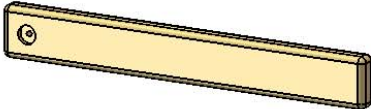
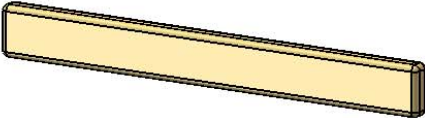
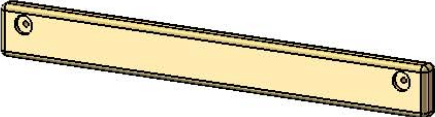
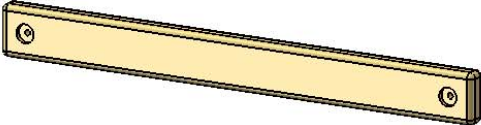

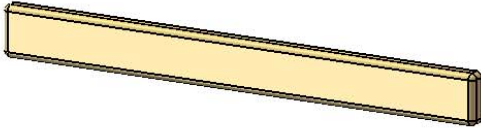
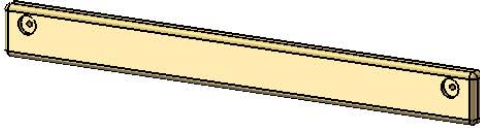
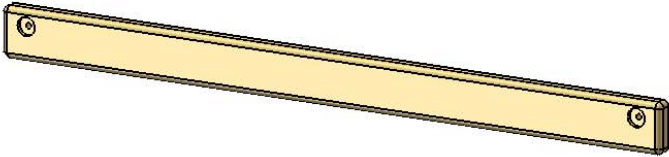
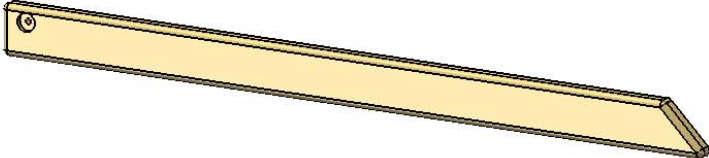
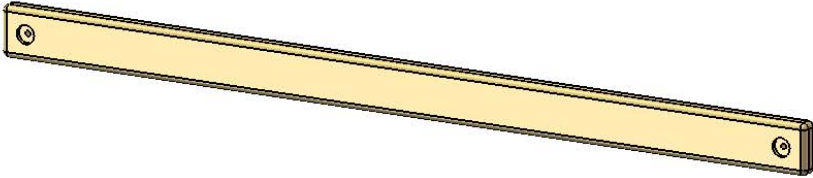
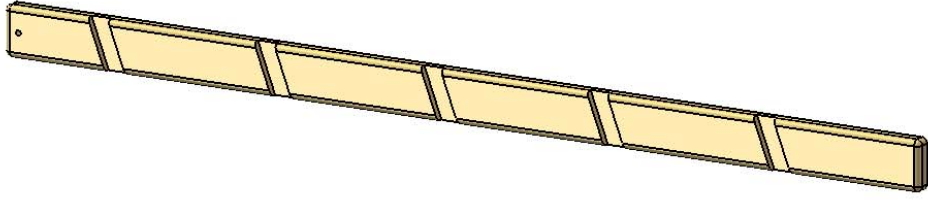
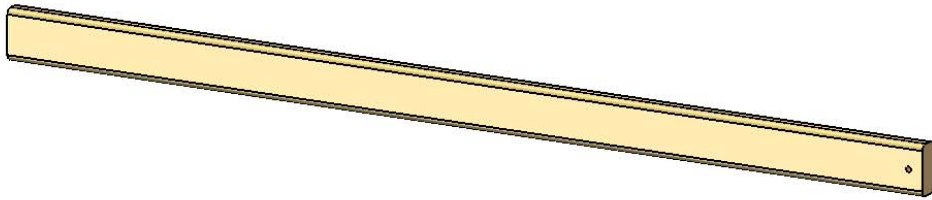
USE THE RULER TO THE RIGHT TO MEASURE YOUR BOLTS AND SCREWS. PICTURE VIEWS SHOWN ABOVE ARE 1:1 SCALE AND CAN BE USED TO MATCH BOLT AND SCREW SIZES.

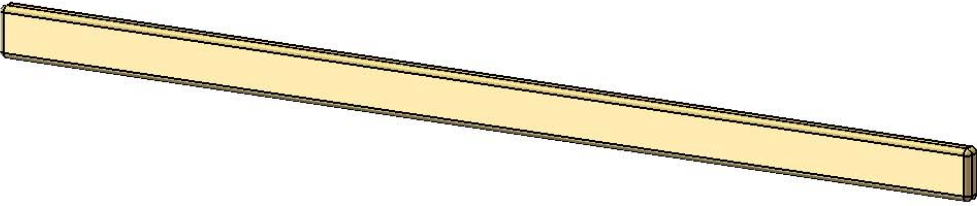
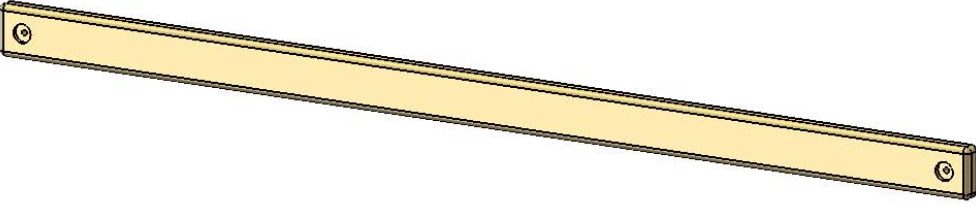
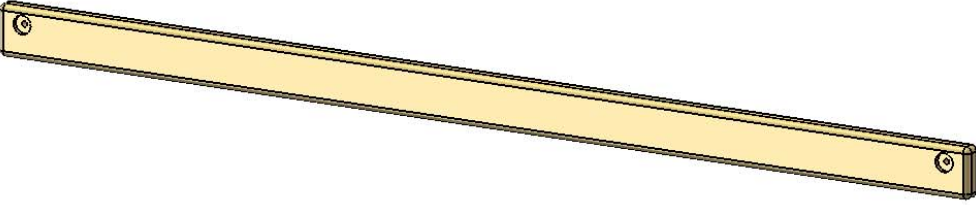
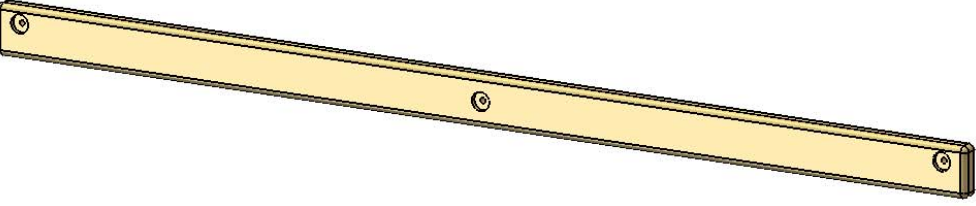
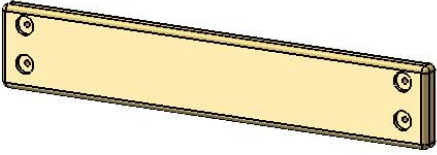
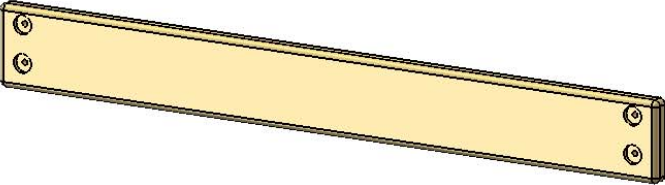
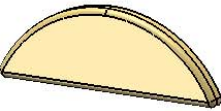
PICTURE	DESCRIPTION	QTY.
	2 X 4 X 15" PICNIC TABLE TOP SUPPORT	2
	2 X 4 X 17" LADDER STEP	5
	2 X 4 X 23" PICNIC TABLE BENCH SUPPORT	2
	2 X 4 X 26" LADDER SIDE BOTTOM PANEL BOARD	1
	2 X 4 X 30" PICNIC TABLE VERTICAL SUPPORT	2
	2 X 4 X 30 ³ / ₄ " UPPER LEVEL CENTER DECK SUPPORT; UPPER LEVEL TOP PANEL BOARD	3
	2 X 4 X 34" UPPER DECK SUPPORT	4

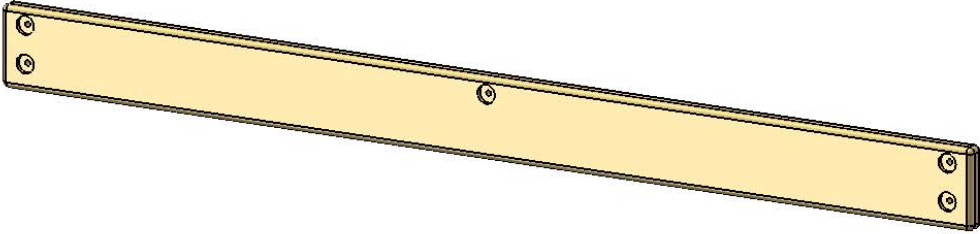
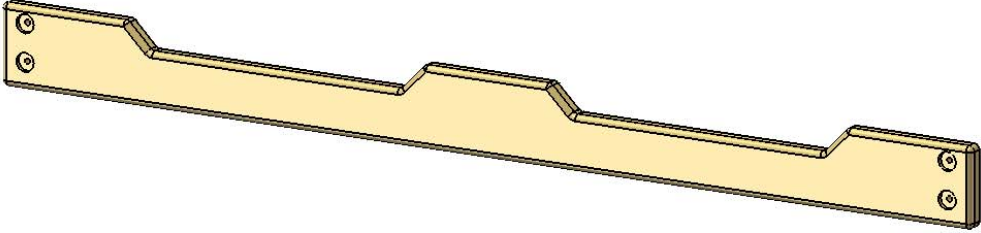
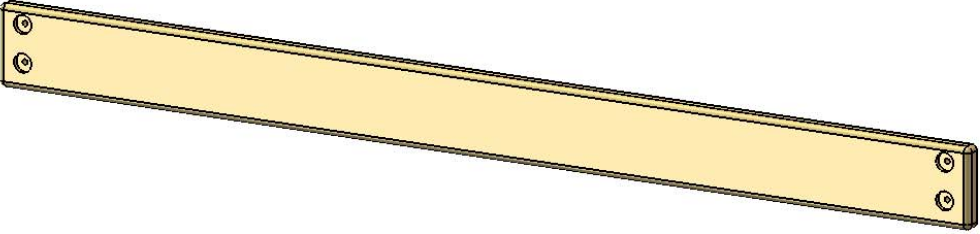
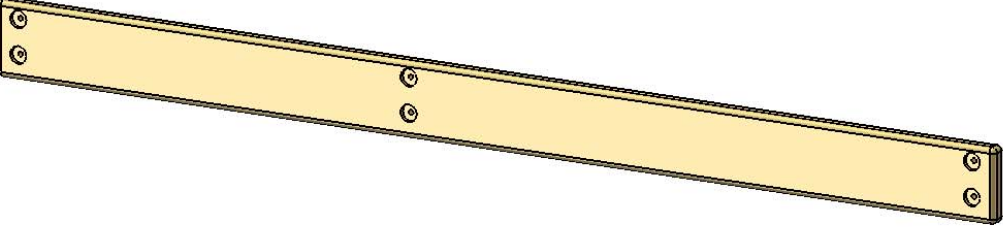
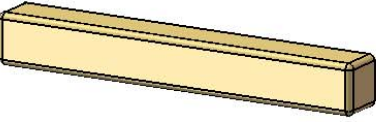
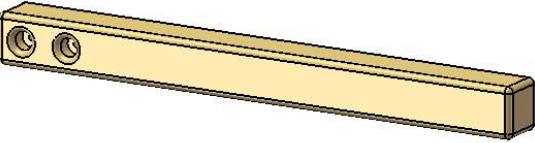
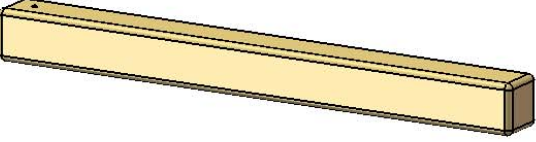

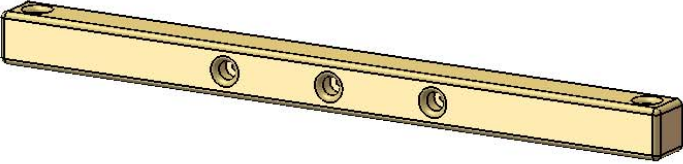
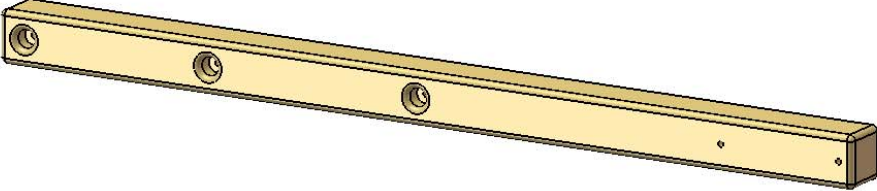

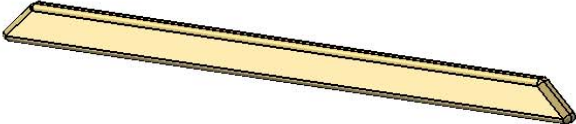
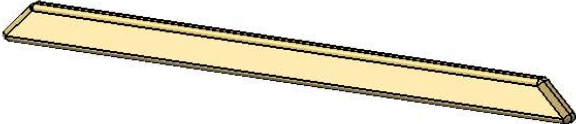
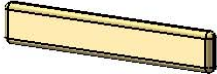
PICTURE	DESCRIPTION	QTY.
	2 X 4 X 34" PORCH CENTER DECK SUPPORT	1
	2 X 4 X 34" PORCH TOP SIDE PANEL BOARD	2
	2 X 4 X 47 ¹ / ₂ " TOP AND BOTTOM PANEL BOARD	2
	2 X 4 X 51" ROOF SUPPORT (LEFT AND RIGHT SIDE)	4
	2 X 4 X 58" SWING LEG CROSS-MEMBER	1
	2 X 4 X 66" LADDER SIDE (LEFT AND RIGHT)	2
	2 X 4 X 66" ROCK WALL SIDE	2

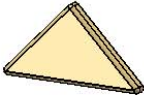
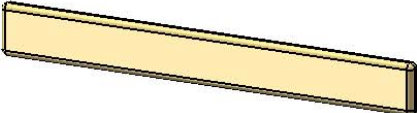
PICTURE	DESCRIPTION	QTY.
	2 X 4 X 70" CENTER DECK SUPPORT	1
	2 X 4 X 70" CENTER DECK SUPPORT; PORCH DECK SANDBOX BOARD	3
	2 X 4 X 70" FRONT TOP PANEL BOARD; REAR PORCH TOP PANEL BOARD	2
	2 X 4 X 70" UPPER LEVEL TOP PANEL BOARD; UPPER LEVEL STEPS	7
	2 X 6 X 30 ³ / ₄ " TOP LEVEL BOTTOM PANEL BOARD	1
	2 X 6 X 47 ¹ / ₂ " LOWER LEVEL BOTTOM PANEL BOARD	2
	2 X 6 X 16" HALF SUN	3

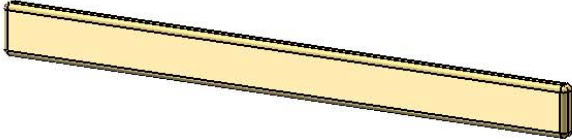
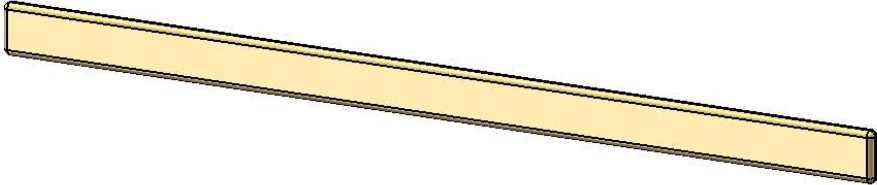
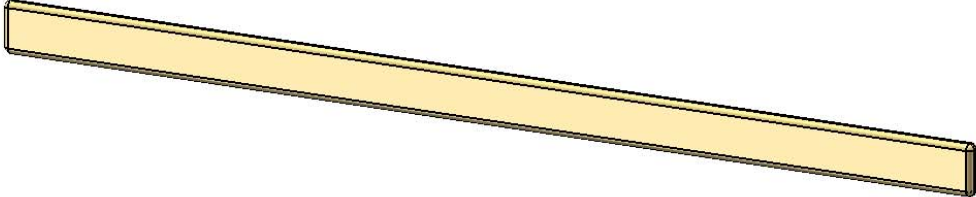
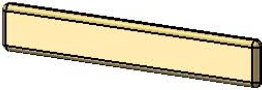
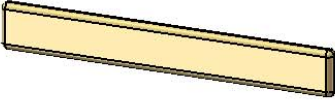
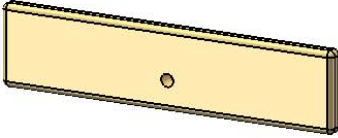
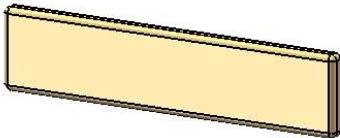

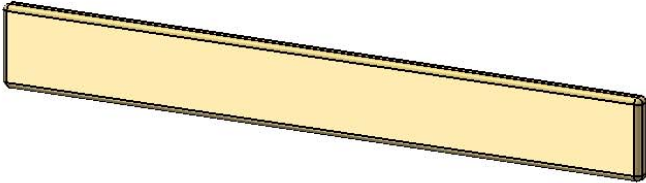
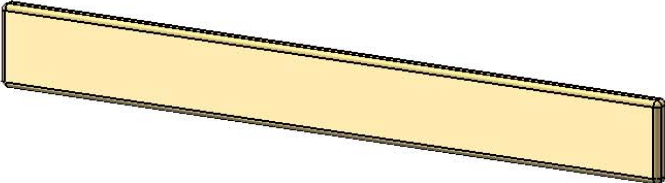
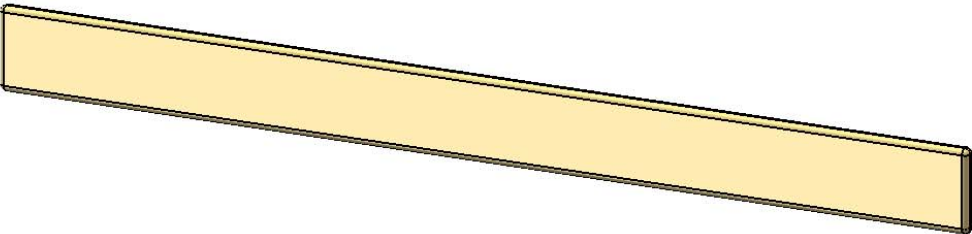
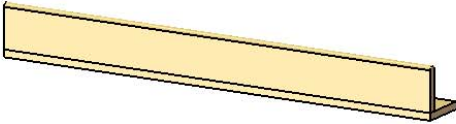
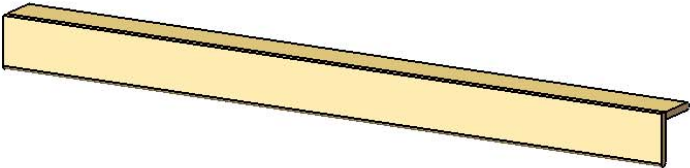
PICTURE	DESCRIPTION	QTY.
	2 X 6 X 70" REAR BOTTOM PANEL BOARD	2
	2 X 6 X 70" FRONT FACE BOARD	1
	2 X 6 X 70" SANDBOX BOARD	2
	2 X 6 X 70" SIDE SANDBOX BOARD BOARD (LEFT AND RIGHT)	2
	4 X 4 X 25 ¹ / ₂ " FRONT CENTER POST	1
	4 X 4 X 37" CENTER LAG POST	1
	4 X 4 X 37" TOP LEVEL REAR CENTER POST	1

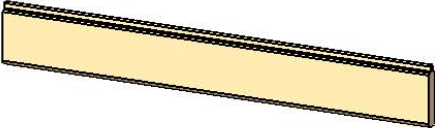
PICTURE	DESCRIPTION	QTY.
	4 X 4 X 47 $\frac{1}{2}$ " SWING BEAM MOUNT	1
	4 X 4 X 61 $\frac{1}{2}$ " CORNER LAG POST (LEFT AND RIGHT)	2
	$\frac{5}{4}$ X 2 X 10" SMALL RAY	18
	$\frac{5}{4}$ X 2 X 16" LARGE RAY	3
	$\frac{5}{4}$ X 3 X 42" SUN SUPPORT	3
	$\frac{5}{4}$ X 4 X 15" PORCH PANEL SLAT	22
	$\frac{5}{4}$ X 4 X 28" PANEL SLAT	29
	$\frac{5}{4}$ X 6 X 10" TRIANGLE ROOF SUPPORT	3
	$\frac{5}{4}$ X 4 X 29 $\frac{3}{4}$ " DECK SPACER	4

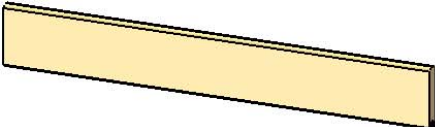
PICTURE	DESCRIPTION	QTY.
	$\frac{5}{4} \times 4 \times 40\frac{5}{8}$ DECK SPACER	2
	$\frac{5}{4} \times 4 \times 62\frac{3}{4}$ DECK SPACER	3
	$\frac{5}{4} \times 4 \times 69\frac{7}{8}$ DECK SPACER	1
	$\frac{5}{4} \times 3 \times 18\frac{1}{2}$ LADDER BACK	1
	$\frac{5}{4} \times 3 \times 23\frac{7}{8}$ ROCK WALL TOP CAP	1
	$\frac{5}{4} \times 6 \times 23\frac{7}{8}$ BOTTOM ROCK WALL BOARD	1
	$\frac{5}{4} \times 6 \times 23\frac{7}{8}$ ROCK WALL BOARD	11

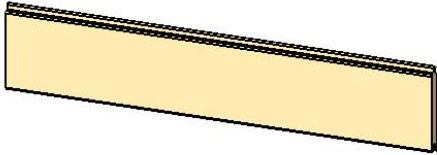
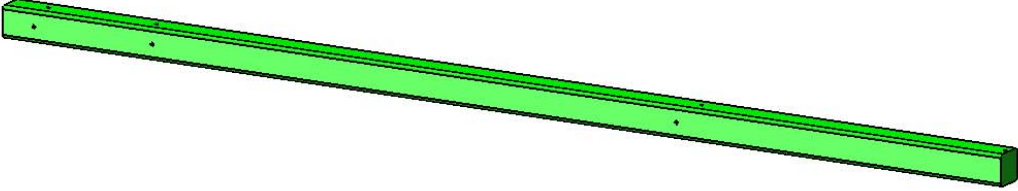
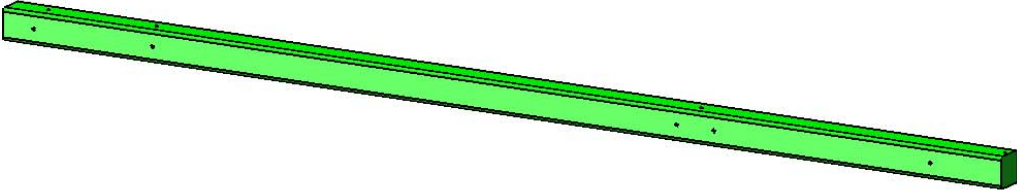
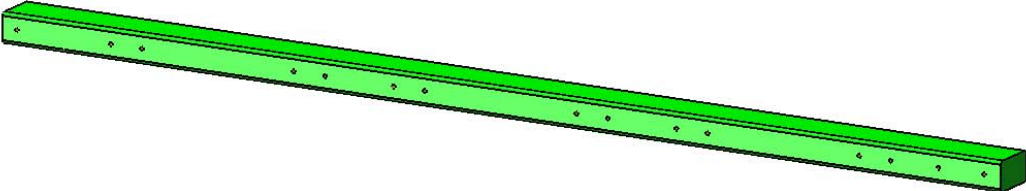
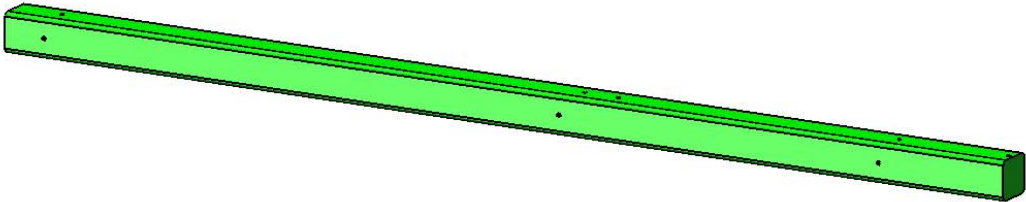
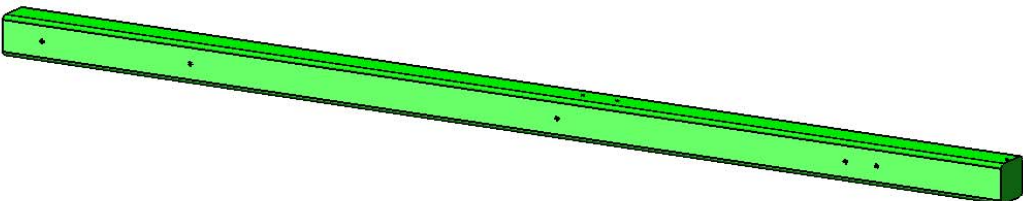
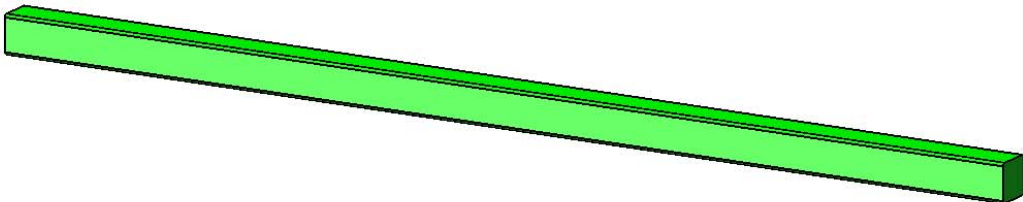
PICTURE		DESCRIPTION	QTY.
		$\frac{5}{4}$ X 6 X 46" PICNIC TABLE SEATS AND TOP	3
		$\frac{5}{4}$ X 6 X $47\frac{1}{2}$ " DECK BOARD	11
		$\frac{5}{4}$ X 6 X $69\frac{7}{8}$ " DECK BOARD	8
		$30\frac{3}{4}$ " ROOF PEAK	1
		$47\frac{1}{2}$ " ROOF PEAK	1
		1 X 4 X $30\frac{3}{4}$ " ROOF FINISHER	2
		1 X 4 X $47\frac{1}{2}$ " ROOF FINISHER	2
		1 X 4 X $30\frac{3}{4}$ " ROOF STARTER	2
		1 X 4 X $47\frac{1}{2}$ " ROOF STARTER	2

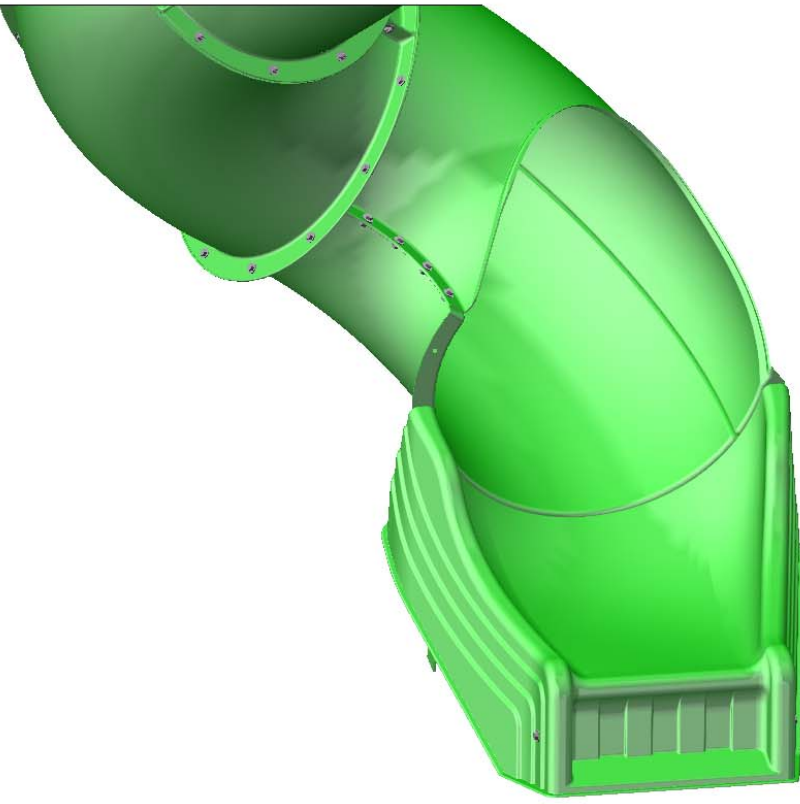
PICTURE		DESCRIPTION	QTY.
		1 X 6 X 30 ³ / ₄ " ROOF BOARD	18
		1 X 6 X 47 ¹ / ₂ " ROOF BOARD	18
		PLASTIC COATED 4 X 4 X 120" LEFT SIDE REAR CORNER POST	1
		PLASTIC COATED 4 X 4 X 120" RIGHT SIDE REAR CORNER POST	1
		PLASTIC COATED 4 X 6 X 120" SWING BEAM	1
		PLASTIC COATED 4 X 4 X 96" FRONT CORNER POST	2
		PLASTIC COATED 4 X 4 X 96" MIDDLE CORNER POST	2
		PLASTIC COATED 4 X 4 X 96" SWING LEG	2

PICTURE	DESCRIPTION	QTY.
	<p>10' WAVE SLIDE</p>	<p>1</p>
	<p>RAD RIDE TUBE SLIDE</p>	<p>1</p>
	<p>SWINGS W/CHAINS</p> <p>TRAPEZE BAR W/CHAINS</p>	<p>2</p> <p>1</p>

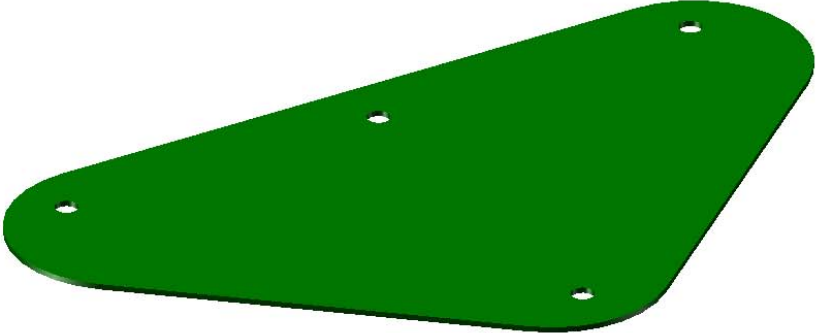
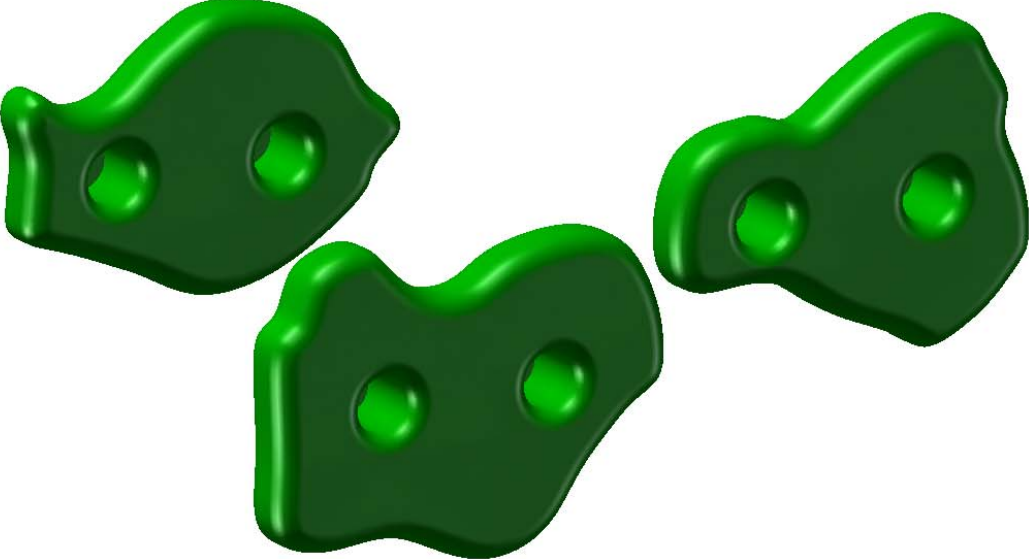
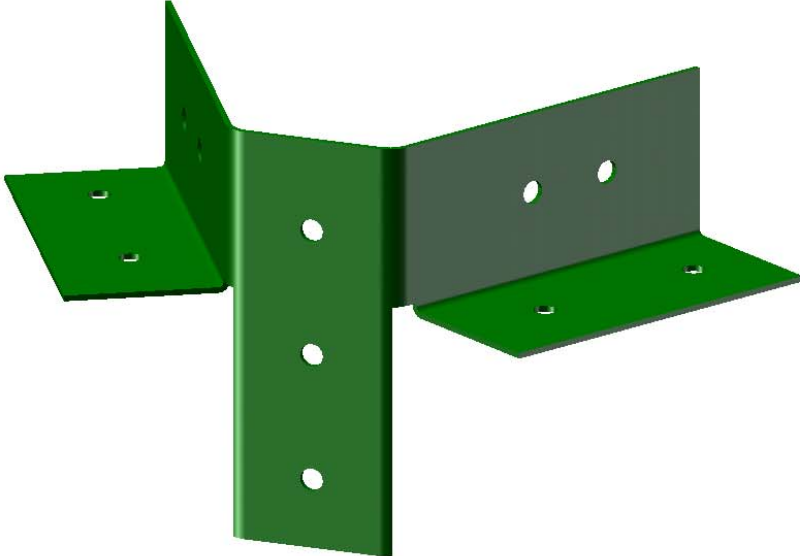
PICTURE	DESCRIPTION	QTY.
	SWING PLATE	1
	CLIMBING ROCKS	10
	A-FRAME SWING LEG BRACKET	1
NOT SHOWN	HARDWARE BOX INSTRUCTIONS	1 EA.

PICTURE

DESCRIPTION

QTY.

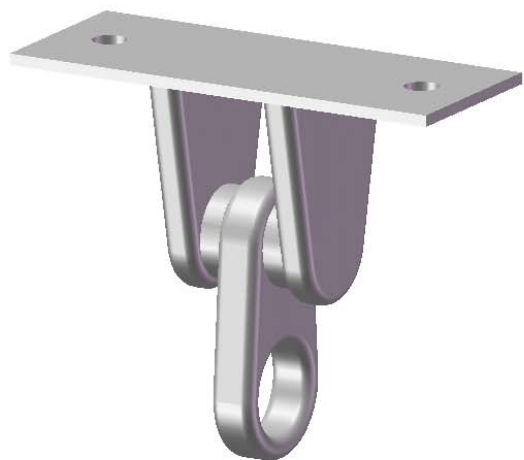

IRON
DUCTILE
SWING
HANGERS

6



TELESCOPE

1

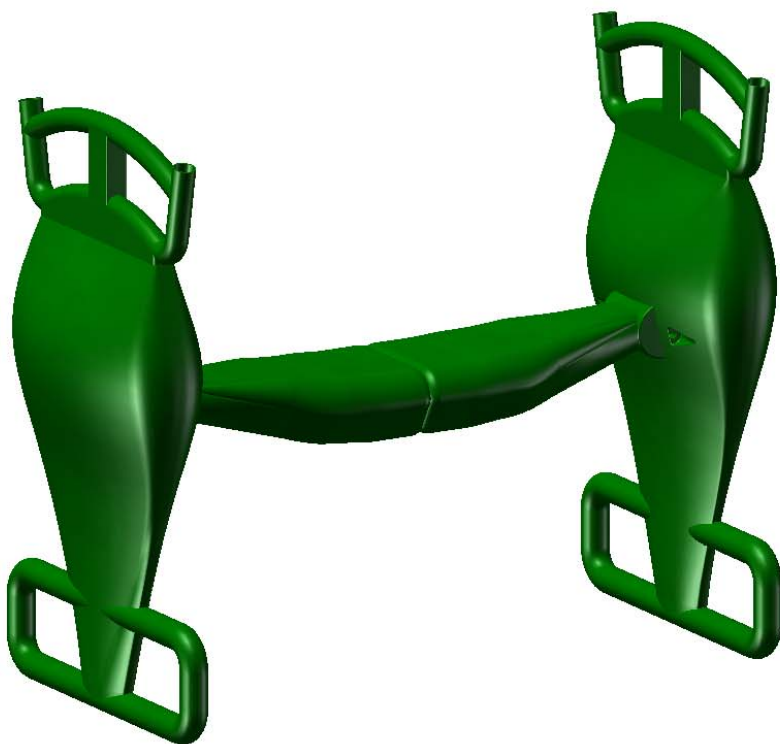

GLIDER
SWING

1

PICTURE	DESCRIPTION	QTY.
	SAFETY HANDLES	2
	1 $\frac{1}{2}$ " X 1 $\frac{1}{2}$ " GREEN BRACKET	4
	SPRING CLIP	6
	10' ROPE	1

PICTURE

DESCRIPTION

QTY.

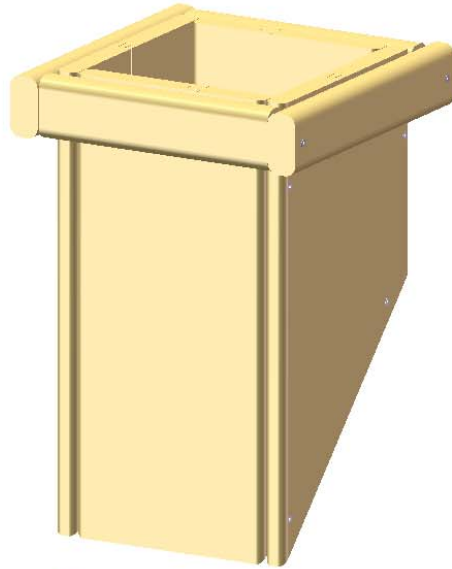

UNASSEMBLED
CHIMNEY

1

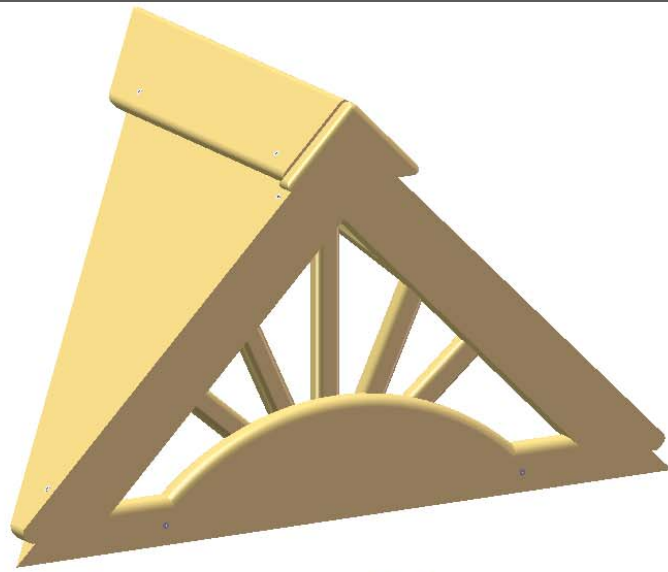

UNASSEMBLED
DORMER

2



TIC-TAC-TOE
PANEL

1

STEP 1A: LEFT SIDE CORNER POSTS

INSERT T-NUTS INTO THE HOLES AS SHOWN BELOW AND SET WITH A HAMMER, FLUSH TO THE SURFACE OF THE CORNER POSTS. T-NUTS MUST BE INSTALLED AT THE PROPER ORIENTATION. MAKE SURE YOUR CORNER POSTS ARE FACING THE PROPER DIRECTION BEFORE INSTALLING T-NUTS.

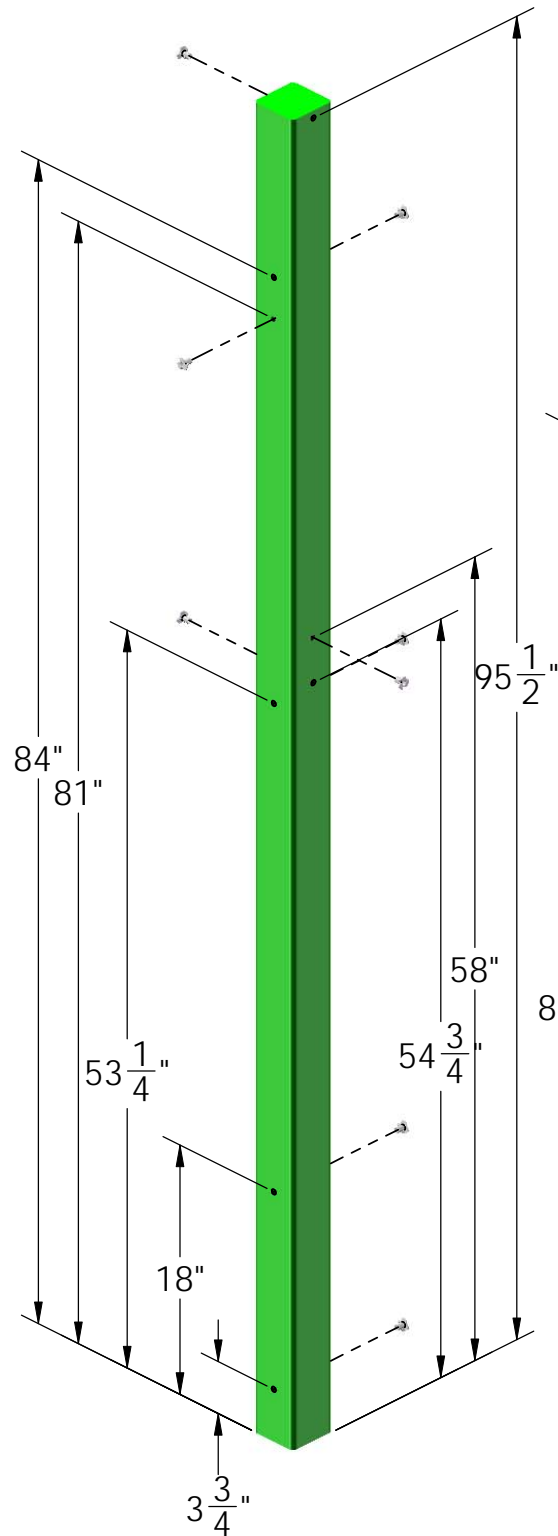

LEFT MIDDLE CORNER POST

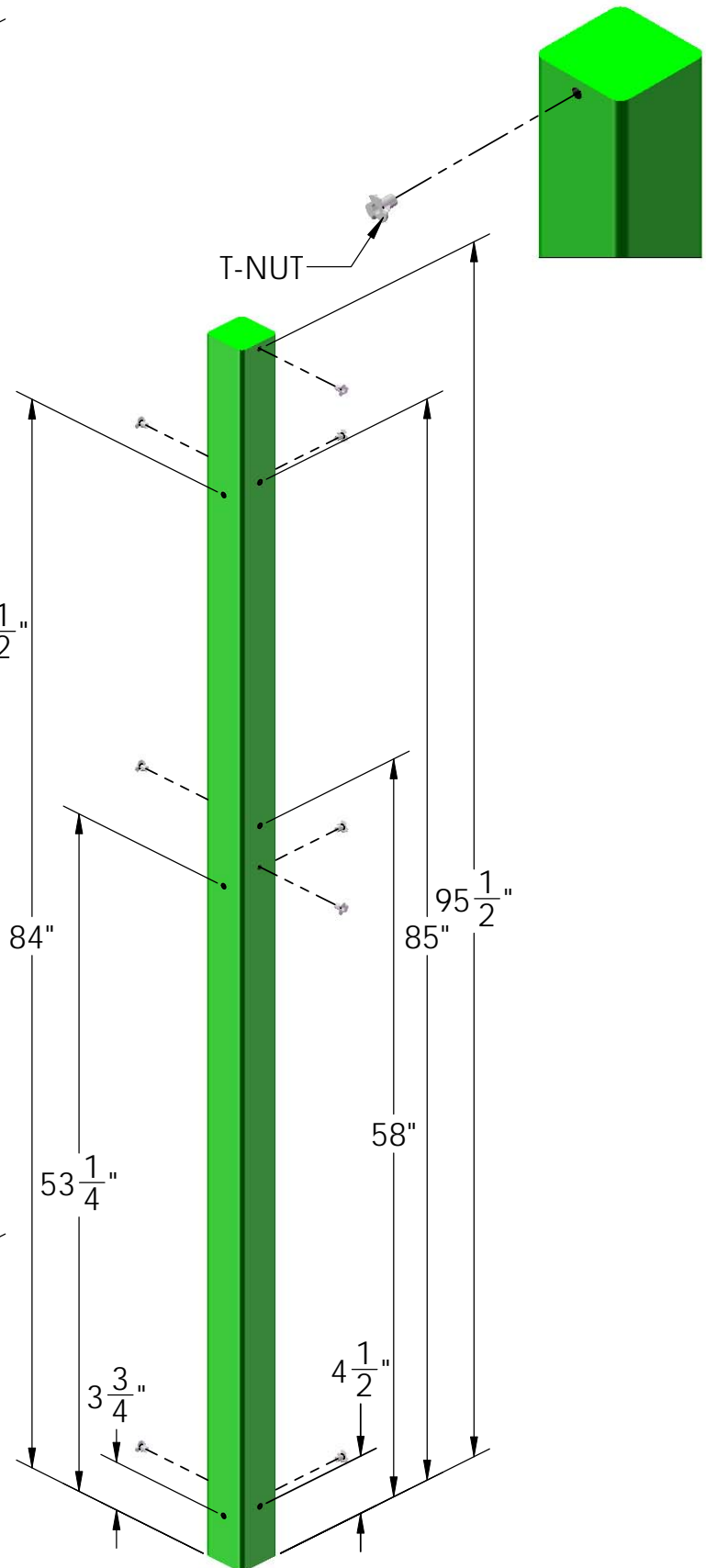

LEFT FRONT CORNER POST

STEP 1B: RIGHT SIDE CORNER POSTS

INSERT T-NUTS INTO THE HOLES AS SHOWN BELOW AND SET WITH A HAMMER, FLUSH TO THE SURFACE OF THE CORNER POSTS. T-NUTS MUST BE INSTALLED AT THE PROPER ORIENTATION. MAKE SURE YOUR CORNER POSTS ARE FACING THE PROPER DIRECTION BEFORE INSTALLING T-NUTS.

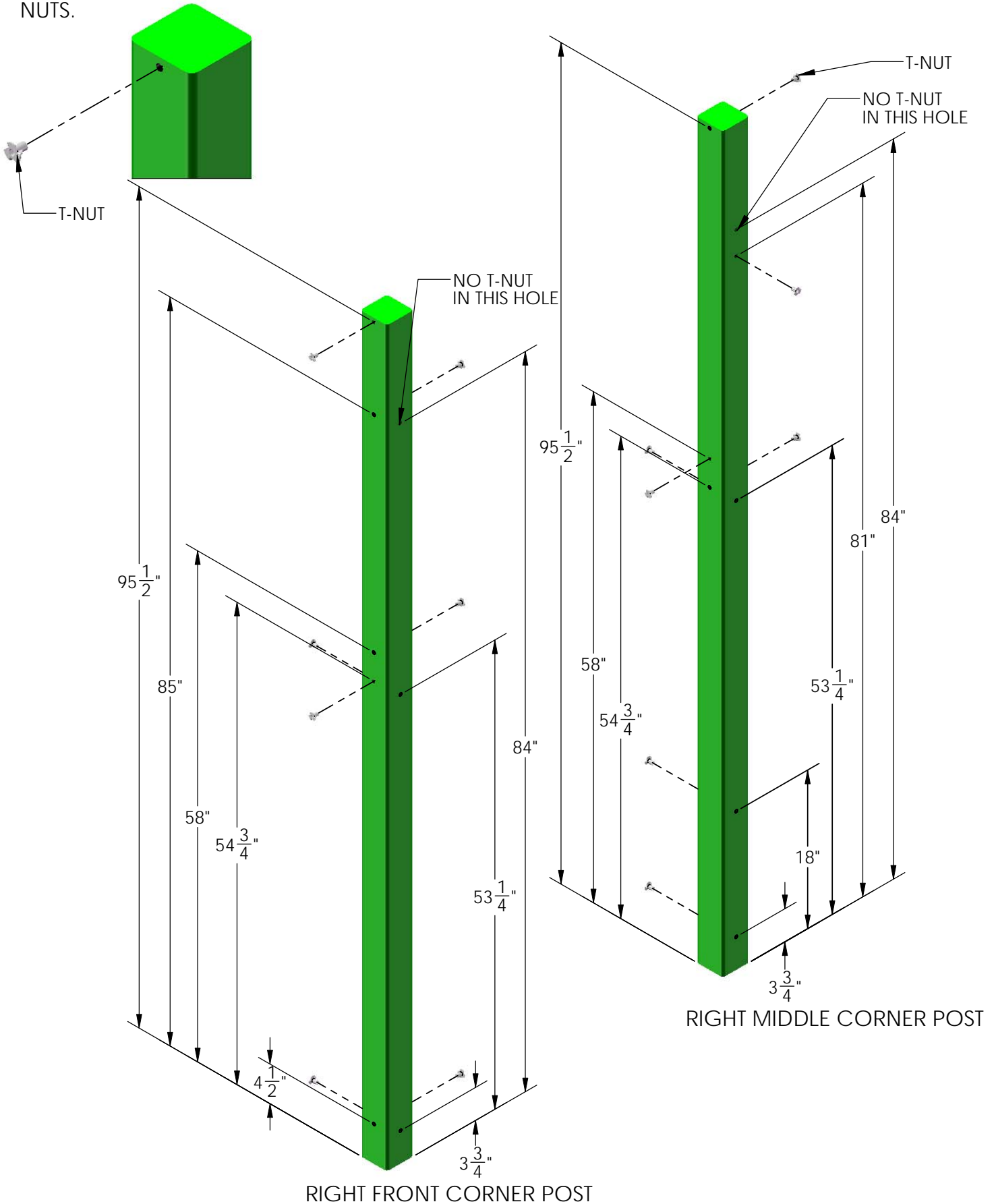

STEP 2: LEFT SIDE WALL ASSEMBLY

1: WITH THE OFFSET HOLES DOWNWARD, LAY ONE 2 X 6 X 78" SANDBOX BOARD ON TOP OF ONE FRONT CORNER POST AND ONE MIDDLE CORNER POST. NOTE THE ORIENTATION OF THE T-NUTS ON THE CORNER POSTS AND THE POSITIONING OF THE CORNER POST ON THE SANDBOX BOARD.

2: USE 5/16 X 4-1/2" HEX BOLTS AND 5/16" WASHERS TO ATTACH THROUGH THE TOP HOLE OF THE SANDBOX BOARD, THROUGH THE HOLES AT 3-3/4" ON THE CORNER POSTS, AND INTO THE T-NUTS INSTALLED IN STEP #1. THE T-NUTS WILL BE ON THE OPPOSITE SIDE OF THE CORNER POSTS AS THE SANDBOX BOARDS. (NOTE: THE BOTTOM HOLE OF THE SANDBOX BOARD WILL NOT BE USED AT THIS TIME)

3: ATTACH THE 2 X 6 X 47-1/2" BOTTOM PANEL BOARD WITH 5/16 X 4-1/2" HEX BOLTS AND 5/16" WASHERS TO THE CORNER POST WITH HOLES OFFSET UP THROUGH THE BOTTOM HOLE OF THE 2 X 6, THROUGH THE HOLES AT 53-1/4", AND INTO THE PREVIOUSLY INSTALLED T-NUT. (NOTE: THE TOP HOLES OF THE BOTTOM PANEL BOARD WILL NOT BE USED AT THIS TIME.)

4: ATTACH THE 2 X 4 X 47-1/2" TOP PANEL BOARD WITH 5/16 X 4-1/2" HEX BOLTS AND 5/16" WASHERS WITH THE HOLES OFFSET DOWN THROUGH THE HOLES AT 84" AND INTO THE T-NUTS.

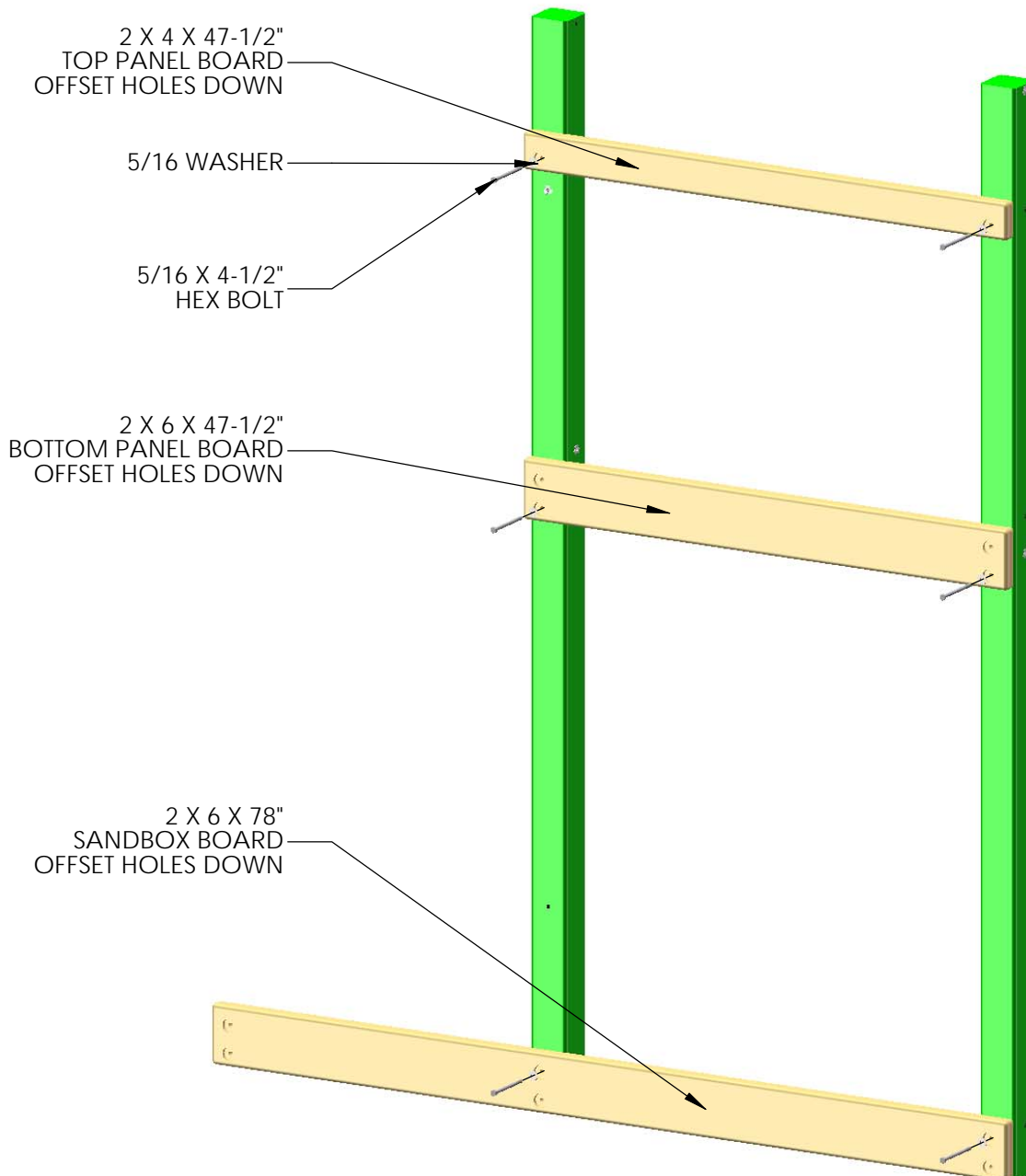

STEP 3: RIGHT SIDE WALL ASSEMBLY

1: ATTACH THE REMAINING 2 X 6 X 78" SANDBOX BOARD ON TOP OF ONE FRONT CORNER POST AND ONE MIDDLE CORNER POST AS PREVIOUSLY EXPLAINED IN THE LEFT SIDE WALL CONSTRUCTION.

2: ATTACH THE 2 X 6 X 47-1/2" BOTTOM PANEL BOARD AS EXPLAINED IN THE LEFT SIDE WALL CONSTRUCTION.

3: ATTACH THE 4 X 4 X 47-1/2" SWING BEAM MOUNT WITH 3/8 X 6-1/2" CARRIAGE BOLTS AND 1/2" WASHERS THROUGH THE HOLES AT 84", THROUGH THE SWING BEAM MOUNT, AND ATTACHED TO 3/8" LOCKNUTS AND WASHERS (AS SHOWN BELOW). (NOTE THE ORIENTATION OF THE HOLES ON THE SWING BEAM MOUNT BELOW)

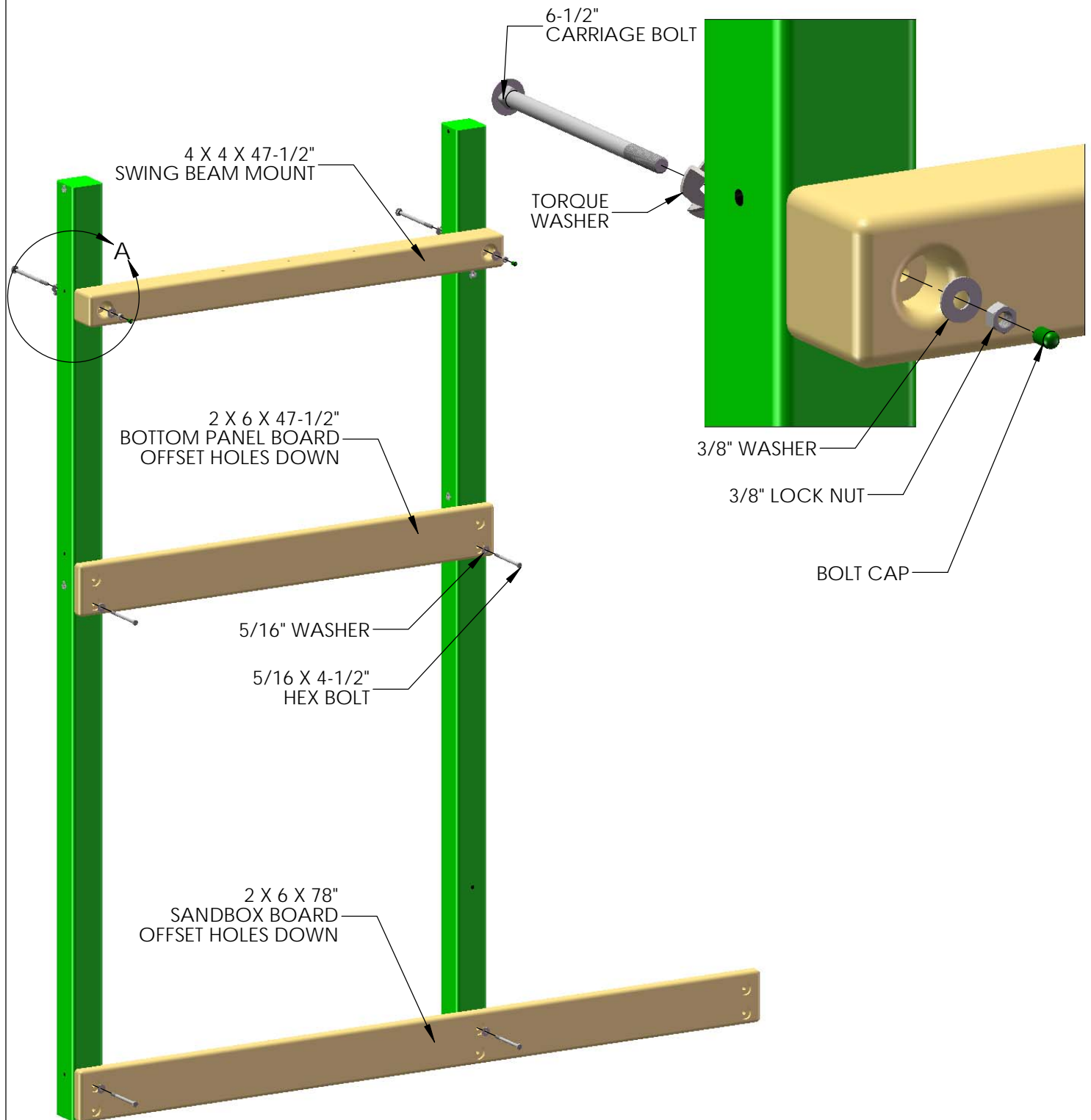

STEP 4: DECK SUPPORTS

1. INSERT 5/16 X 4-1/2" HEX HEAD BOLTS AND 5/16" WASHERS THROUGH THE 2 X 4 X 70" DECK SUPPORTS, THROUGH THE HOLES AT 54-3/4", AND INTO THE T-NUTS INSTALLED IN STEP #1.
2. PLACE THE 2 X 4 X 70" PORCH DECK SANDBOX BOARD FLUSH TO THE BOTTOM OF THE PREVIOUSLY INSTALLED SANDBOX BOARDS AND TO THE INSIDE OF THE CORNER POST. ATTACH IT TO THE CORNER POSTS WITH TWO 5/16 X 3-1/2" LAG SCREWS AND 5/16" WASHERS.

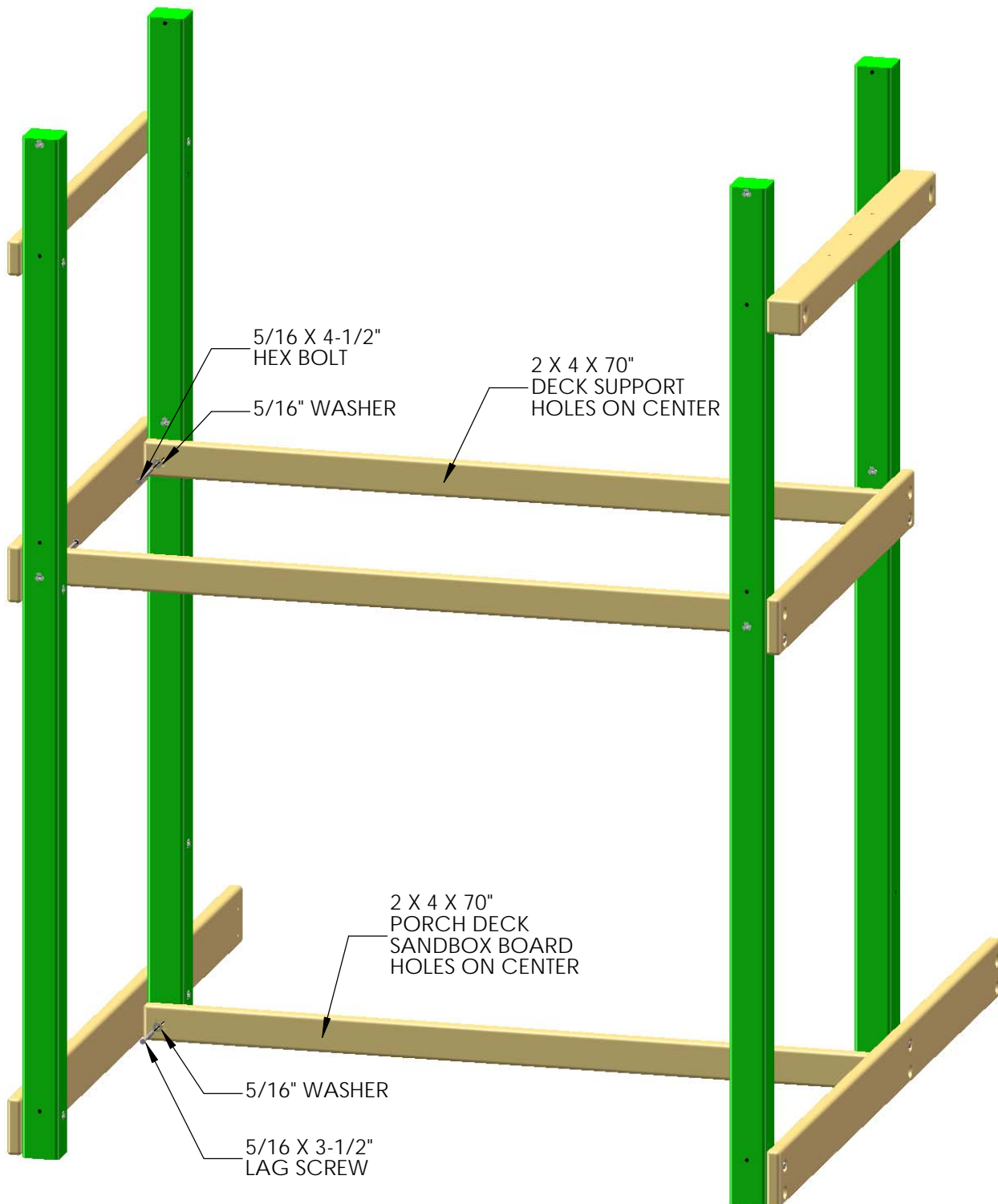

STEP 5: PANEL BOARDS

1: ATTACH THE 2 X 4 X 47-1/2" BOTTOM PANEL BOARD ON TOP OF THE RIGHT SIDE BOTTOM PANEL BOARD WITH TWO 5/16 X 3-1/2" LAG SCREWS.

2: ATTACH THE 2 X 6 X 70" FRONT FACE BOARD TO THE FRONT CORNER POSTS WITH 5/16 X 4-1/2" HEX BOLTS AND 5/16" WASHERS THROUGH THE TOP HOLE OF THE FRONT FACE BOARD, THROUGH THE HOLES AT 58", AND INTO THE PREVIOUSLY INSTALLED T-NUTS. (NOTE: THE BOTTOM HOLES OF THE FRONT FACE BOARD WILL NOT BE USED AT THIS TIME)

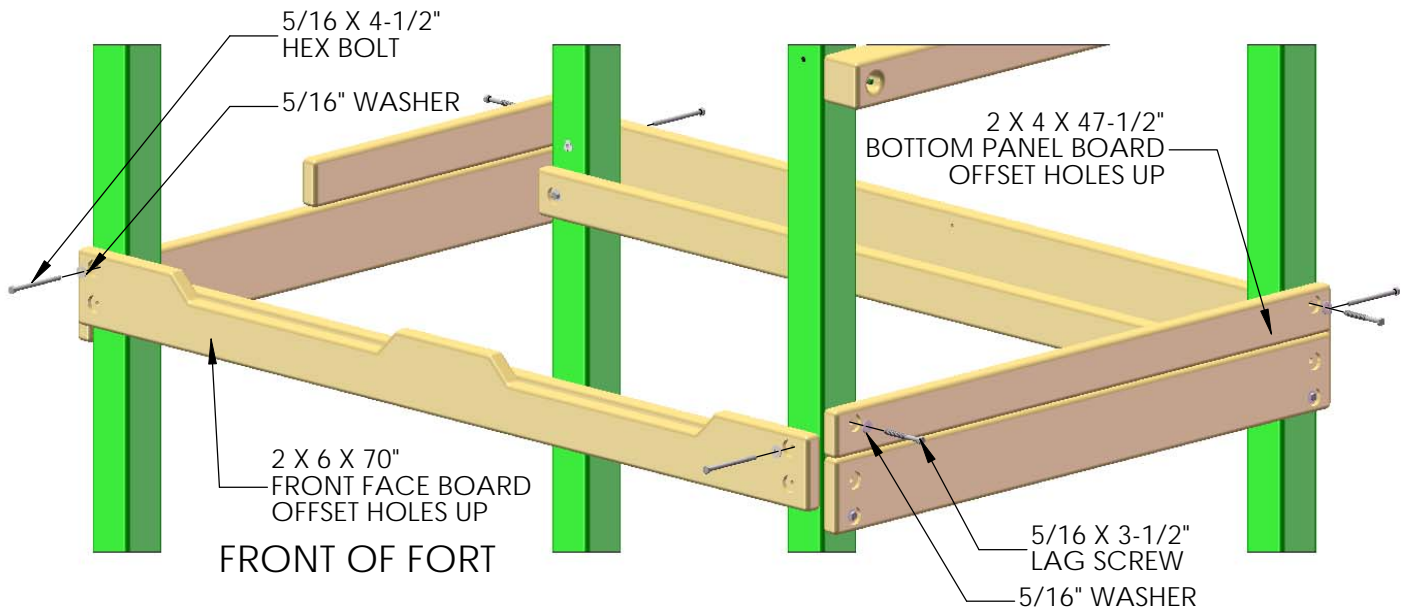

3: PLACE THE 2 X 4 X 26" LADDER SIDE BOTTOM PANEL ON TOP OF THE LEFT SIDE BOTTOM PANEL BOARD AND FLUSH TO THE OUTSIDE OF THE CORNER POST. ATTACH IT WITH ONE 5/16 X 3-1/2" LAG SCREW AND 5/16" WASHER AS SHOWN BELOW.

4: ATTACH THE 2 X 6 X 70" BACK PANEL BOARD TO THE MIDDLE CORNER POSTS WITH 5/16 X 4-1/2" HEX BOLTS AND 5/16" WASHERS THROUGH THE TOP HOLE OF THE BACK PANEL BOARD, THROUGH THE HOLES AT 58", AND INTO THE PREVIOUSLY INSTALLED T-NUTS. (NOTE: THE BOTTOM HOLES WILL NOT BE USED AT THIS TIME)

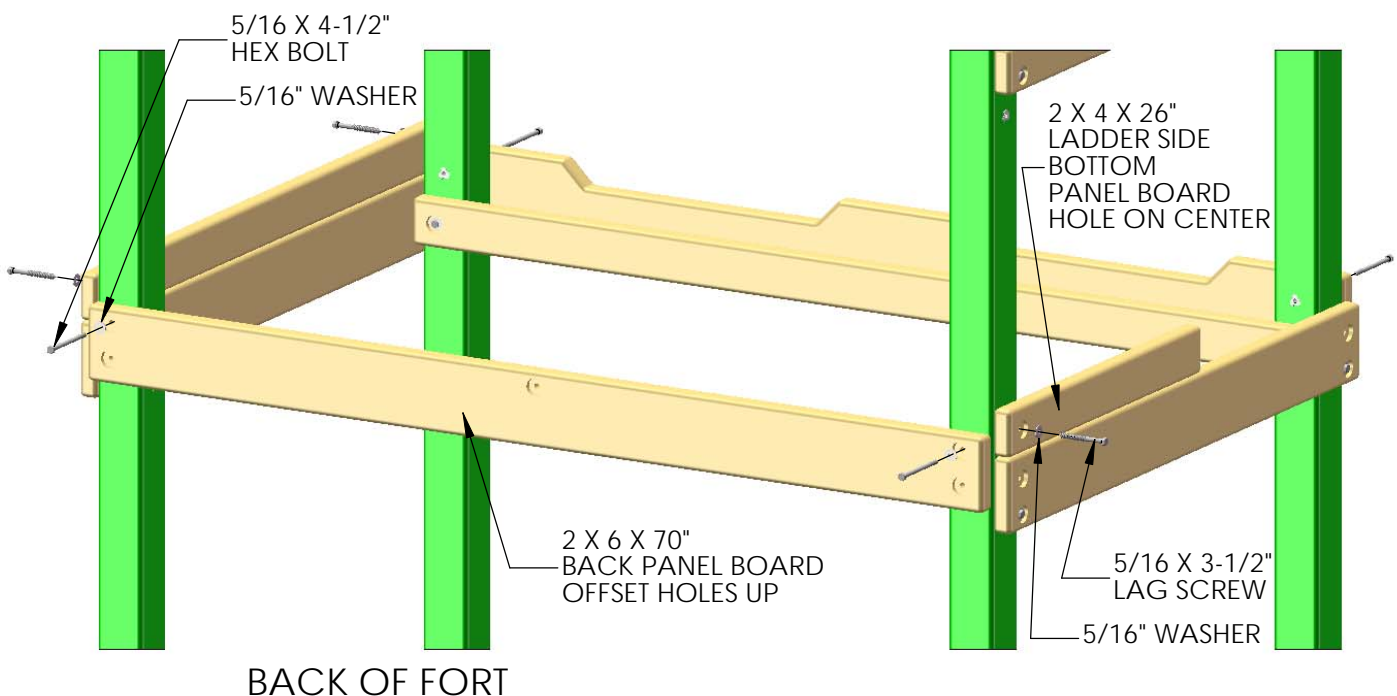

STEP 6: COMPLETING THE FRAME

1: ATTACH THE 2 X 6 X 70" SANDBOX BOARD WITH HOLES OFFSET UP TO THE FRONT CORNER POSTS WITH 5/16 X 4-1/2" HEX BOLTS AND 5/16" WASHERS THROUGH THE TOP HOLES OF THE SANDBOX BOARD, THROUGH THE HOLES AT 4-1/2", AND INTO THE PREVIOUSLY INSTALLED T-NUTS. (THE BOTTOM HOLES WILL NOT BE USED AT THIS TIME)

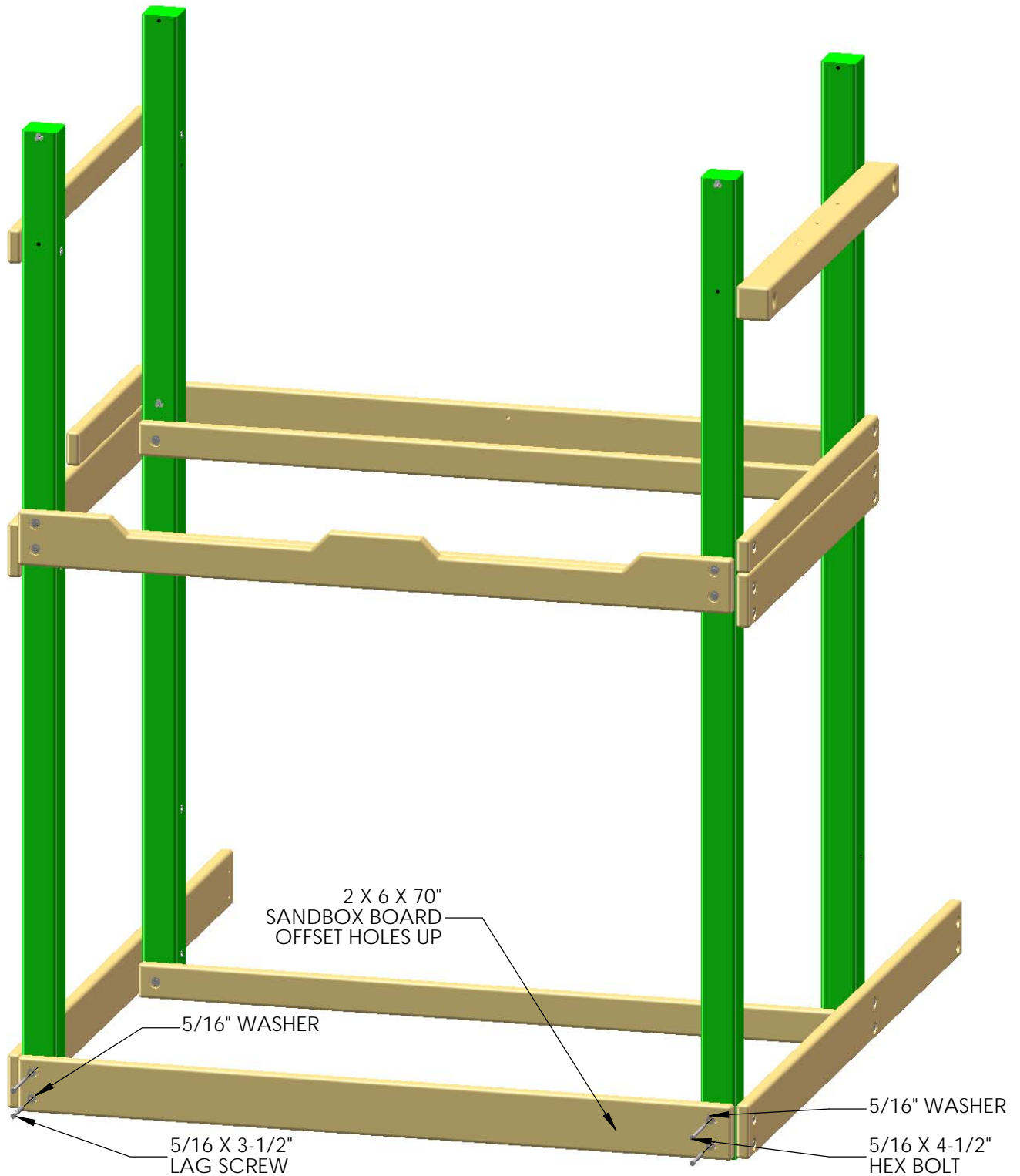

2: ONCE THE FRAME IS LEVEL, SQUARE, AND SET INTO POSITION YOU MAY GO BACK THROUGH AND INSERT THE 5/16 X 3-1/2" LAG SCREWS AND 5/16" WASHERS IN ALL OF THE REMAINING HOLES OF THE PREVIOUSLY INSTALLED 2 X 6 PARTS. NOTE: THERE WILL NOT BE ANY PRE- DRILLED HOLES IN THE CORNER POSTS FOR THESE LAG SCREWS. LAG SCREWS ARE SELF-TAPPING.

STEP 7: LOWER LEVEL DECK

1: YOU WILL NEED TO PREDRILL THE ENDS OF THE DECK BOARDS TO PREVENT INSTALLATION DAMAGE. PREDRILL BOTH ENDS WITH A 1/8" DRILL BIT USING THE DIMENSIONS BELOW. DRILL A HOLE IN THE CENTER OF ALL DECK BOARDS.

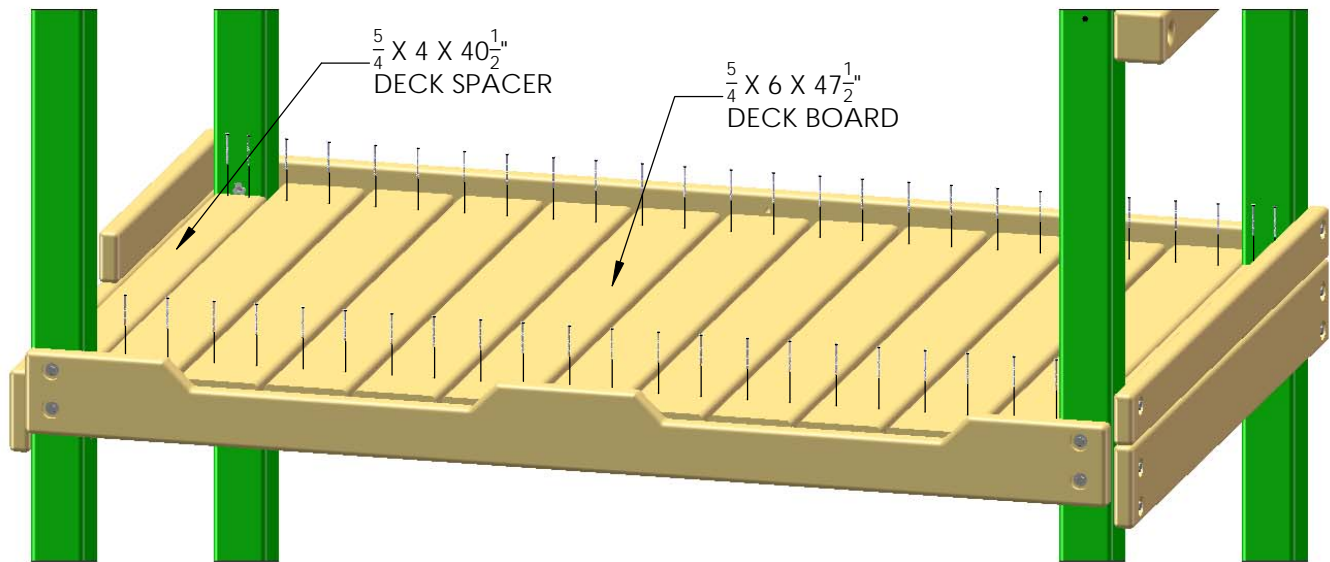
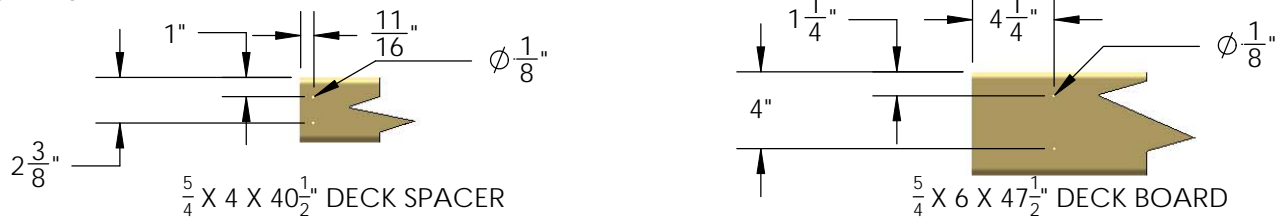

2: PLACE THE 40-1/2" DECK SPACERS BETWEEN THE FRONT AND MIDDLE CORNER POSTS. SECURE THE DECK SPACERS TO THE DECK SUPPORTS WITH 2" WOOD SCREWS THROUGH THE PRE-DRILLED HOLES.

3: PLACE THE ELEVEN 47-1/2" DECK BOARDS MAKING SURE THAT THEY ARE EVENLY SPACED. SECURE WITH TWO 2" WOOD SCREWS PER SIDE. **PLACE ALL DECK BOARDS ACROSS THE DECK BEFORE FASTENING.**

4: FIND THE CENTER POINT OF THE DECK SPACERS ON EACH END OF THE DECK AND MARK THIS POINT.

5: CENTER THE CENTER DECK SUPPORT ON THE MARKS AND POSITION IT FLUSH TO THE DECK BOARDS. SECURE THE CENTER DECK SUPPORT WITH 2-1/2" WOOD SCREWS THROUGH THE OUTSIDE OF THE BOTTOM PANEL BOARDS AND INTO THE ENDS OF THE CENTER DECK SUPPORT. ATTACH THE CENTER OF THE DECK BOARDS TO THE CENTER DECK SUPPORT FROM THE TOP WITH 2" WOOD SCREWS THROUGH THE DECK BOARDS AND INTO THE TOP OF THE 2 X 4 X 70".

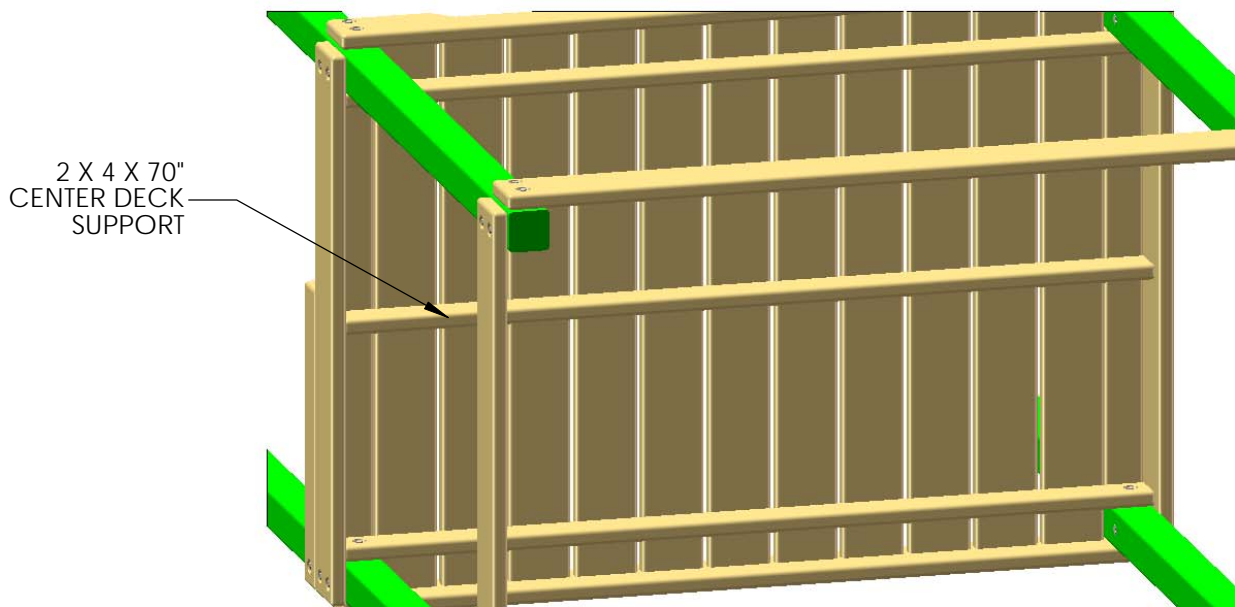

VIEW SHOWN FROM UNDERNEATH FORT

STEP 8: FRONT TOP PANEL BOARD

1: FIND THE 2 X 4 X 70" FRONT TOP PANEL BOARD.

2: ATTACH THE FRONT TOP PANEL BOARD TO THE FRONT CORNER POSTS WITH 5/16 X 4-1/2" HEX BOLTS AND 5/16" WASHERS WITH HOLES OFFSET UP THROUGH THE HOLES AT 85" AND INTO THE T-NUTS.

NOTE: THE 7/8" THROUGH HOLE SHOULD BE TO THE RIGHT SIDE OF THE FORT.

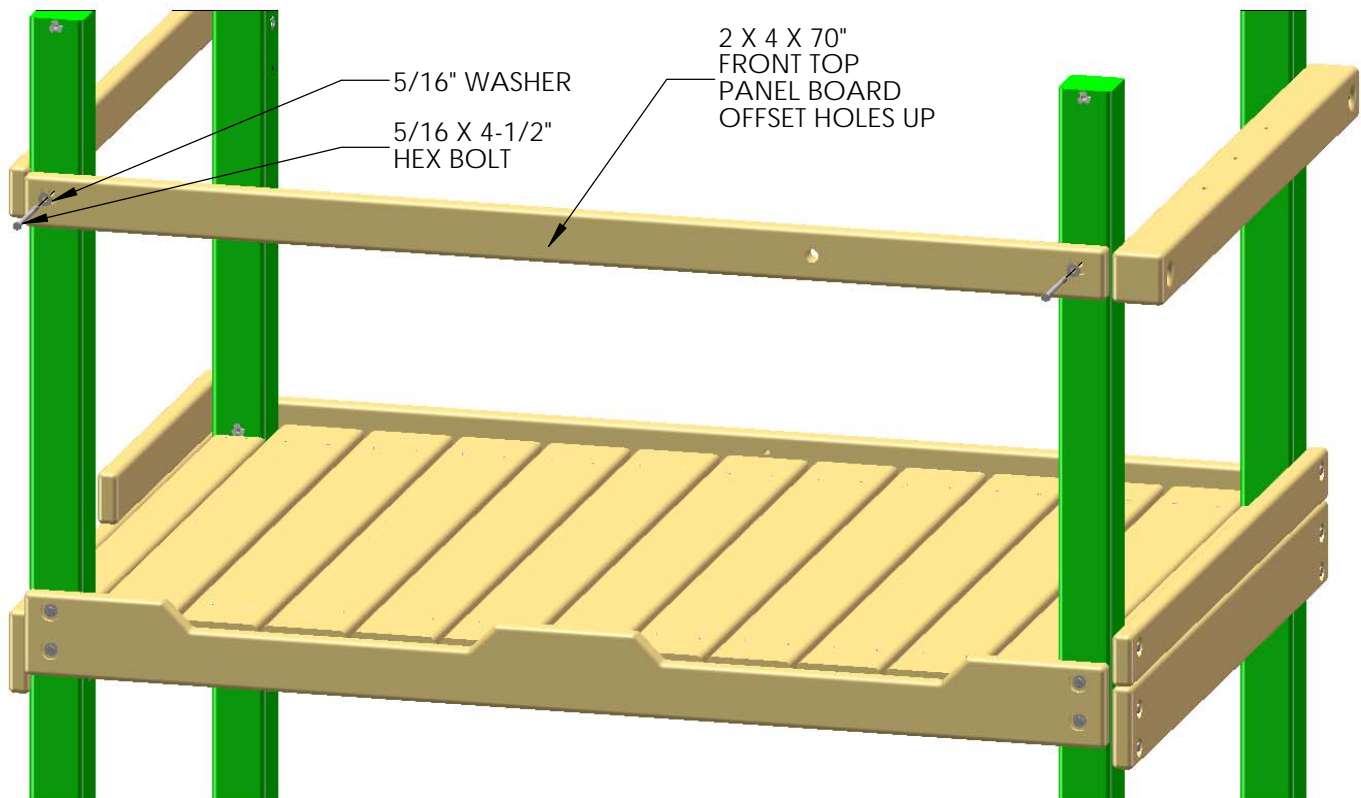

STEP 9: CENTER POST

1: FIND THE 4 X 4 X 25-1/2" CENTER POST.

2: CENTER THE CENTER POST TO THE CENTER OF THE REAR BOTTOM PANEL BOARD, AND ATTACH WITH A 5/16 X 3-1/2" LAG SCREW AND A 5/16" WASHER FROM THE BACK; THROUGH THE HOLE IN THE REAR BOTTOM PANEL BOARD; INTO THE CENTER POST.

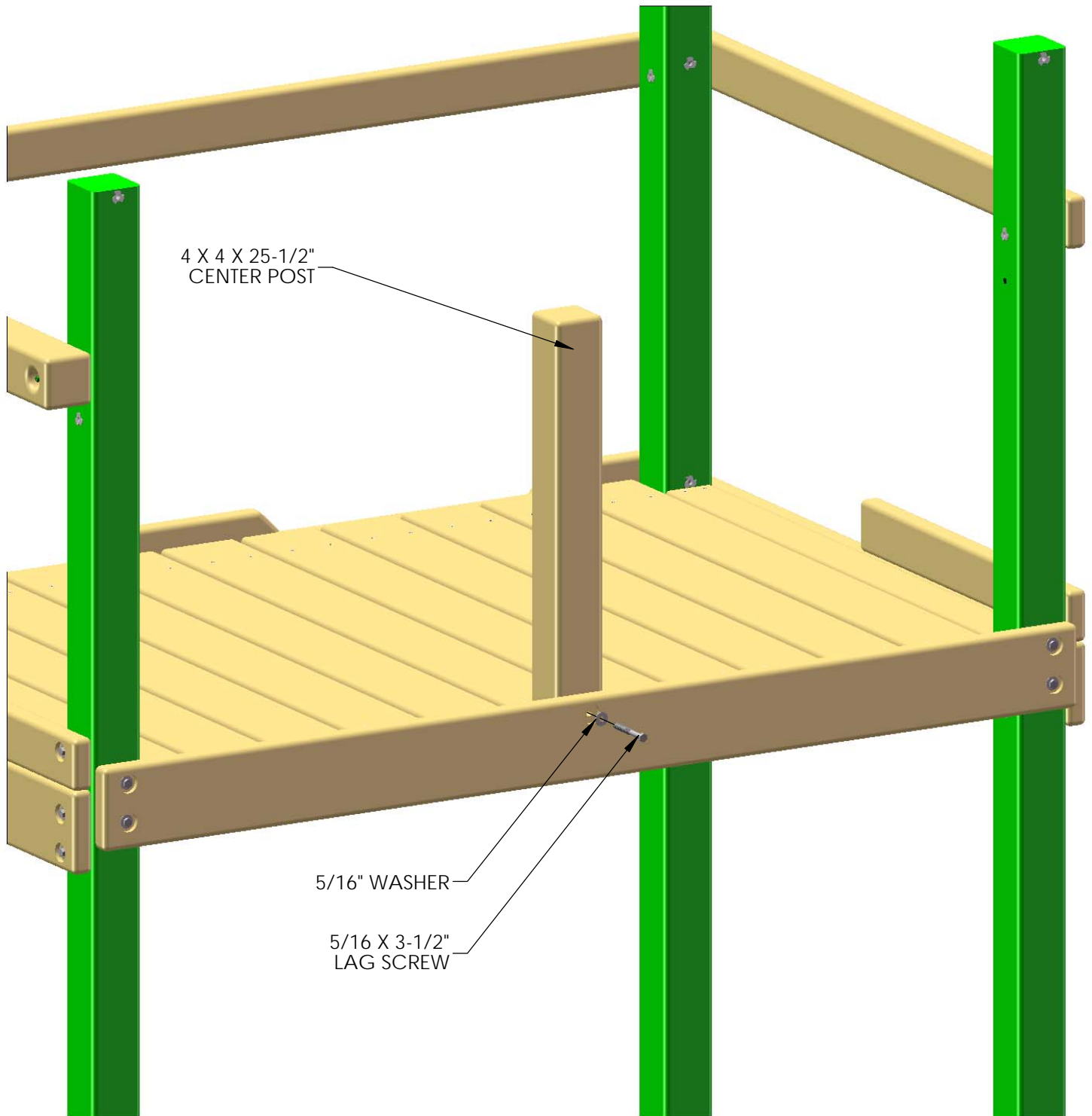

STEP 10: STEP BOARDS

- 1: FIND FOUR 2 X 4 X 70" 3 HOLE PANEL BOARDS.
- 2: PLACE ONE PANEL BOARD ON TOP OF THE DECK TO THE INSIDE OF THE REAR WALL. USE A 2 X 4 AS A SPACER FOR THE NEXT THREE AS SHOWN IN **FIGURE A**.
- 3: ATTACH THE 3 HOLE PANEL BOARDS TO THE CORNER AND CENTER POSTS WITH THREE 5/16 X 3-1/2" LAG SCREWS AND 5/16" WASHERS PER BOARD.

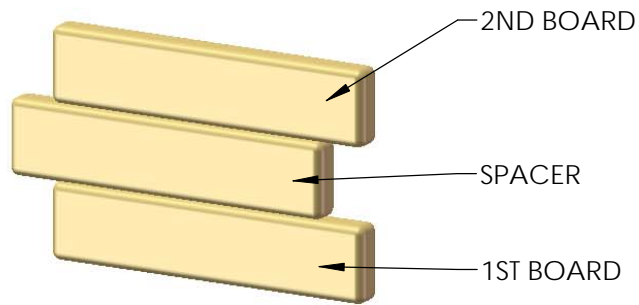
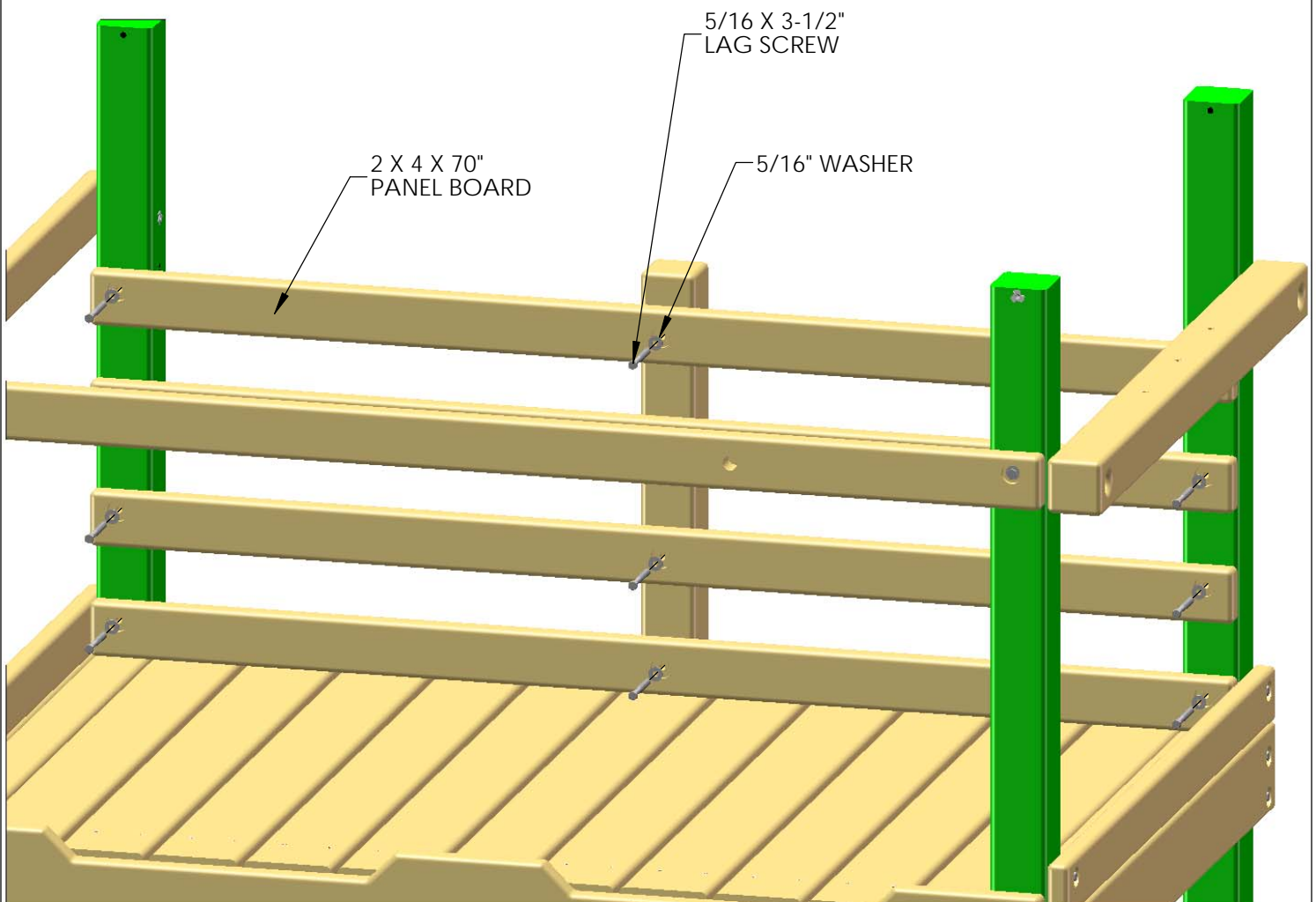
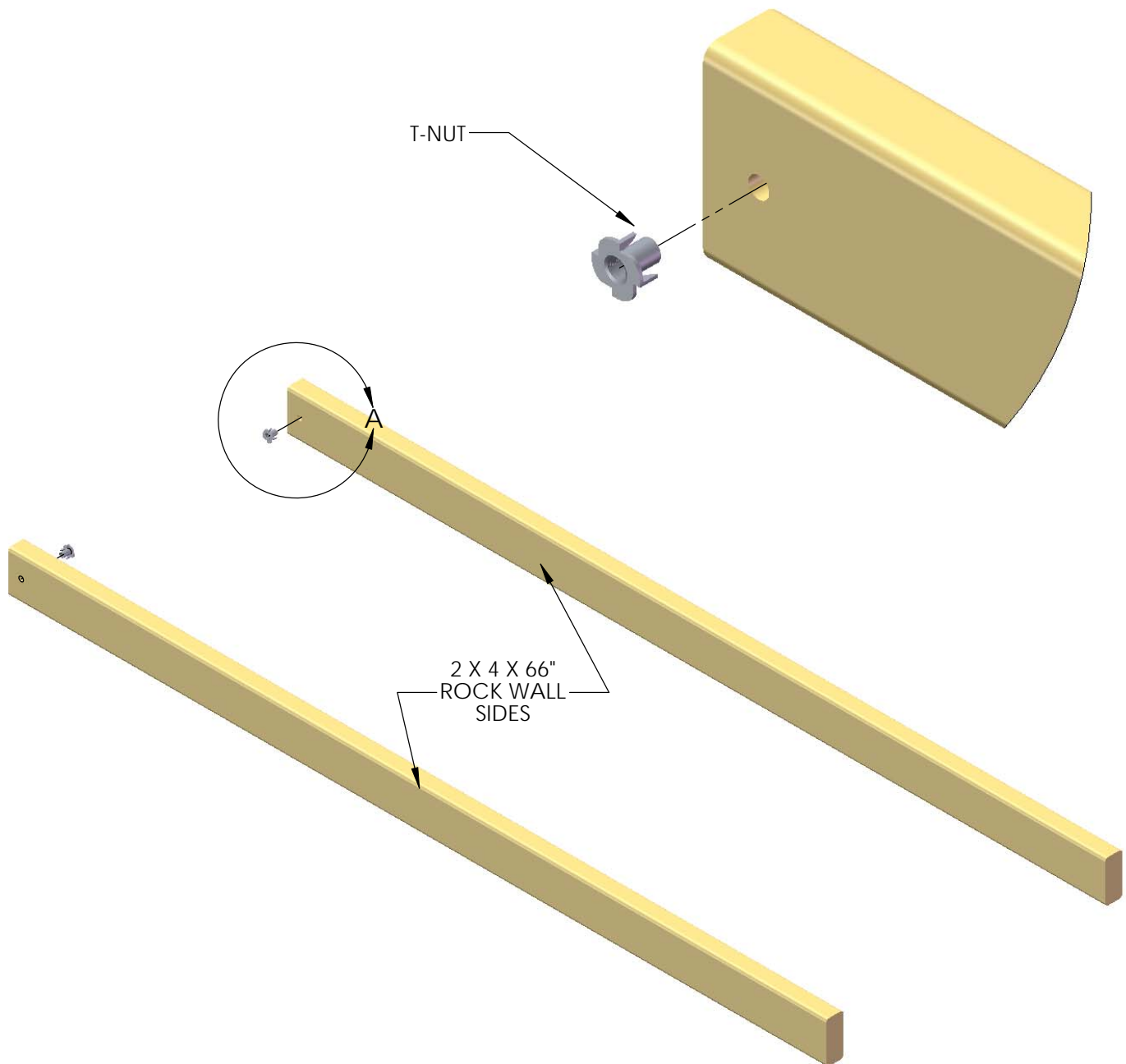

FIGURE A



STEP 11: ROCK WALL

- 1: FIND TWO 2 X 4 X 66" ROCK WALL SIDES.
- 2: POSITION THE ROCK WALL SIDES SO THAT THE HOLES IN THE BOARDS ARE BOTH FACING THE SAME WAY.
- 3: INSERT T-NUTS INTO THE INSIDE OF THE ROCK WALL SIDES AND SET WITH A HAMMER.



STEP 12: ROCK WALL

- 1: FIND ELEVEN 5/4 X 6 X 23-7/8" ROCK WALL BOARDS, AND ONE 5/4 X 6 X 23-7/8" BOTTOM ROCK WALL BOARD(1 HOLE).
- 2: STARTING FROM THE TOP, PLACE ONE ROCK WALL BOARD ON TOP OF THE ROCK WALL SIDES, FLUSH TO THE TOP OF THE ROCK WALL SIDES, AND ATTACH WITH TWO 2" WOOD SCREWS IN EACH SIDE.
- 3: CONTINUE DOWN THE ROCK WALL WITH THE REMAINING ROCK WALL BOARDS, FASTENING EACH BOARD WITH TWO 2" WOOD SCREWS ON EACH END.
- 4: THE FINAL BOARD WILL BE THE BOTTOM ROCK WALL BOARD WITH ONE HOLE. ATTACH WITH TWO 2" WOOD SCREWS PER SIDE.
- 5: IN SOME CASES, THERE WILL BE EXCESS LENGTH ON THE ROCK WALL SIDES. THIS IS DUE TO MILLING VARIATIONS, AND IS ALSO USED TO HELP LEVEL THE ROCK WALL SIDES ON UNEVEN GROUND.
- 6: ROCK WALL SIDES MAY NOT BE EVEN WITH THE BOTTOM ROCK WALL BOARD DUE TO MILLING VARIATIONS AND WOOD SHRINKAGE.

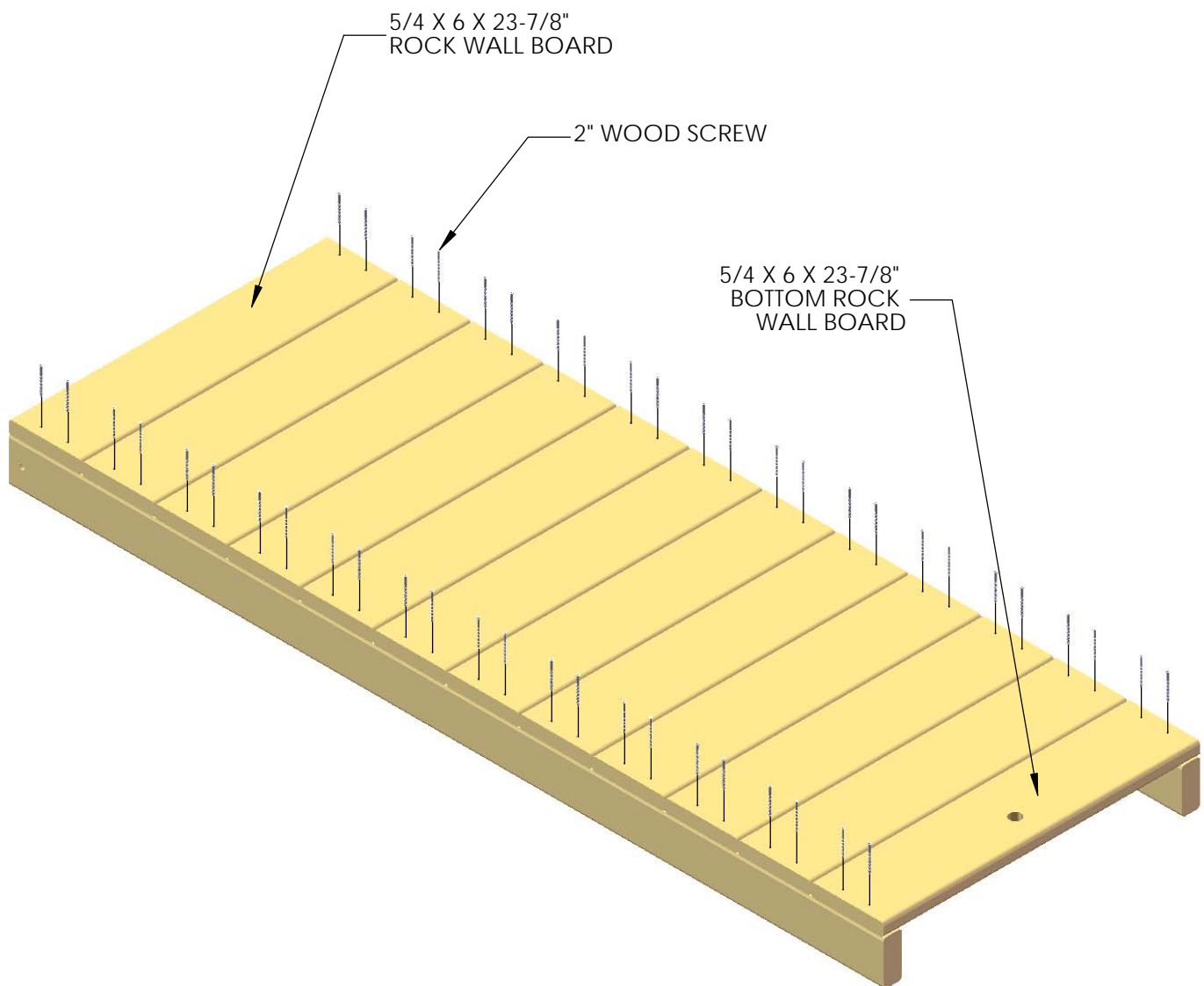

STEP 13: ROCK WALL

1: FASTEN THE 90° GREEN BRACKET TO THE ROCK WALL SIDES WITH 5/16" X 1-1/2" HEX BOLTS AND 5/16" WASHERS.

2: DO NOT FULLY TIGHTEN THE HEX BOLTS INTO THE T-NUTS AT THIS TIME.

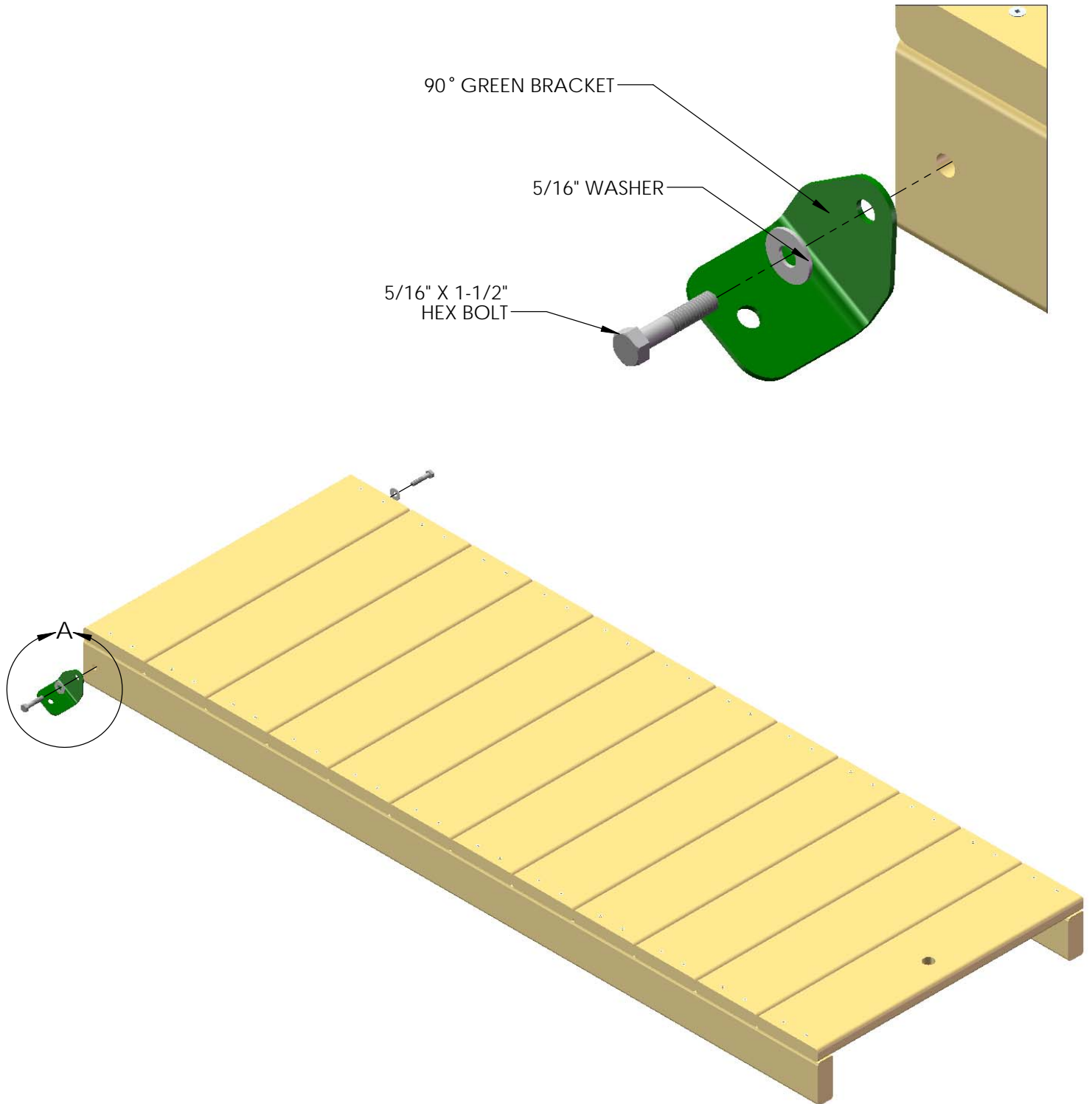

STEP 14: ROCK WALL

1: FIND TEN ROCKS AND TWENTY 1-1/4" PAN HEAD SCREWS.

2: MOUNT THE ROCKS IN A STAGGERED MANNER ON THE ROCK WALL BOARDS. TWO PAN HEAD SCREWS WILL SECURE EACH ROCK TO THE WALL.

NOTE: THE IMAGE SHOWN BELOW IS A GENERIC ARRANGEMENT OF ROCKS ON THE ROCK WALL. YOUR ACTUAL CONFIGURATION MAY BE DIFFERENT THAT WHAT YOU SEE BELOW. ROCKS CAN BE ARRANGED IN ANY PATTERN AS LONG AS THEY WILL ALLOW PROPER ACCESS TO THE FORT. BE CREATIVE!

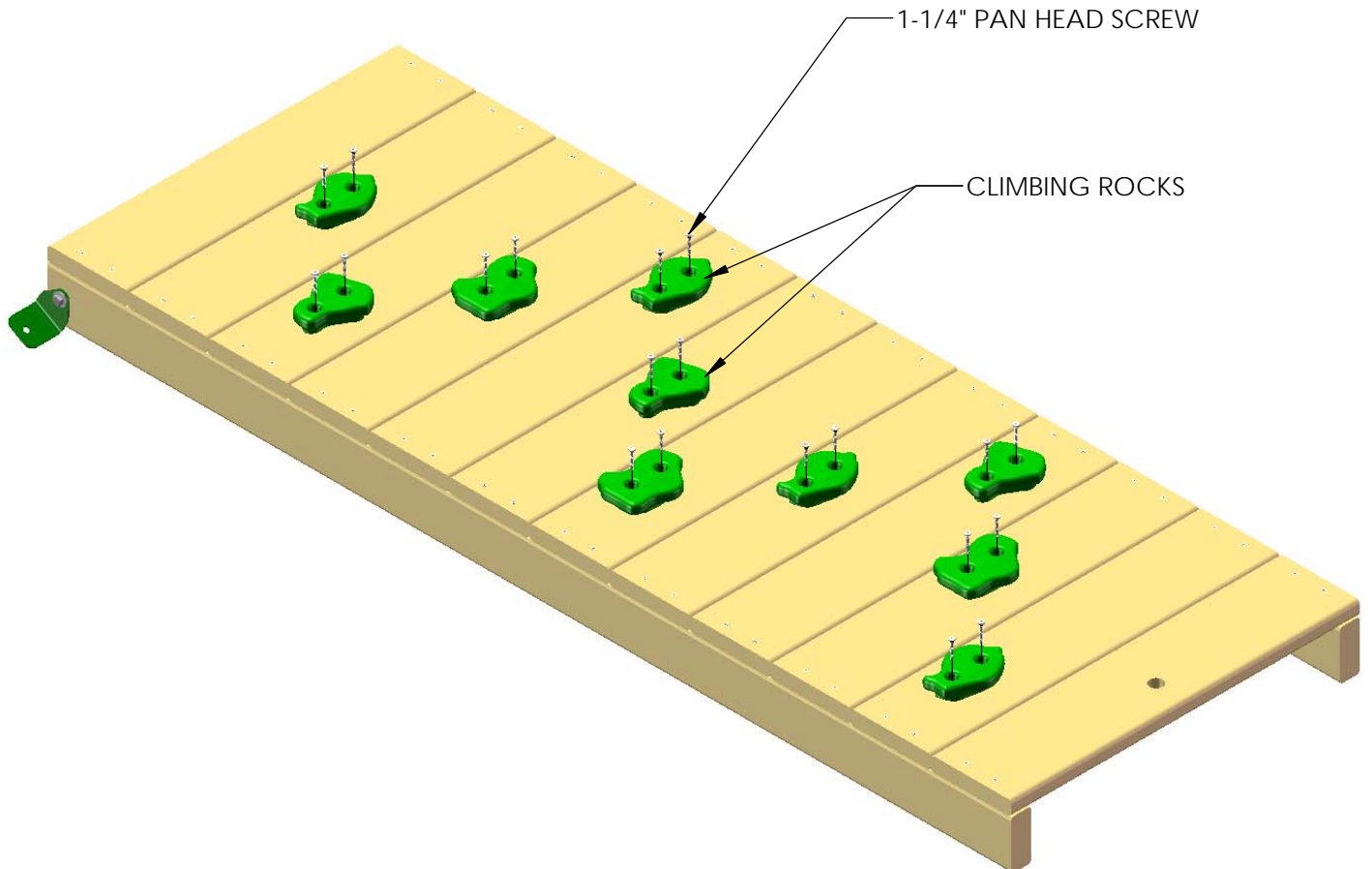

3: PLACE THE 5/4 X 3 X 23-7/8" ROCK WALL TOP CAP ON TOP OF THE ROCK WALL SIDES. FASTEN THE ROCK WALL TOP CAP TO THE ROCK WALL SIDES WITH 2" WOOD SCREWS.

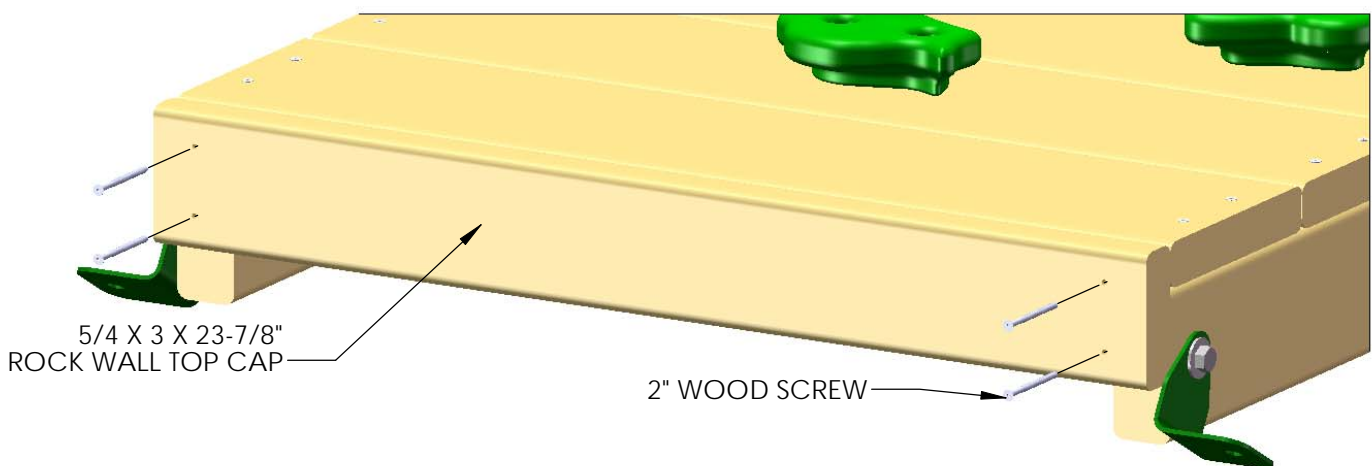

STEP 15: ROCK WALL

- 1: PLACE THE ROCK WALL INTO POSITION ON THE FORT AS SHOWN BELOW. USING THE 90° BRACKETS AS A TEMPLATE; DRILL A 3/8" HOLE THROUGH THE FRONT FACE BOARD.
- 2: FROM THE UNDERSIDE OF THE DECK, INSERT A T-NUT INTO THE BACK SIDE OF THE 3/8" HOLES ON THE FRONT FACE BOARD.
- 3: ATTACH THE ROCK WALL WITH 5/16 X 1-1/2" HEX BOLTS AND 5/16" WASHERS.
- 4: WHEN THE BRACKETS ARE SECURE, AND THE ROCK WALL IS IN ITS FINAL POSITION; TIGHTEN THE 5/16 X 1-1/2" BOLTS ON THE ROCK WALL SIDES.
- 5: THREAD ROPE THROUGH THE HOLE ABOVE THE ROCK WALL. TIE A SECURE KNOT ON THE INSIDE OF THE TOP PANEL BOARD.
- 6: THREAD THE OPPOSITE END OF THE ROPE THROUGH THE HOLE IN THE BOTTOM ROCK WALL BOARD; PULL TIGHT AND TIE A KNOT BEHIND THE ROCK WALL, MAKING SURE THE ROPE IS TIGHT.

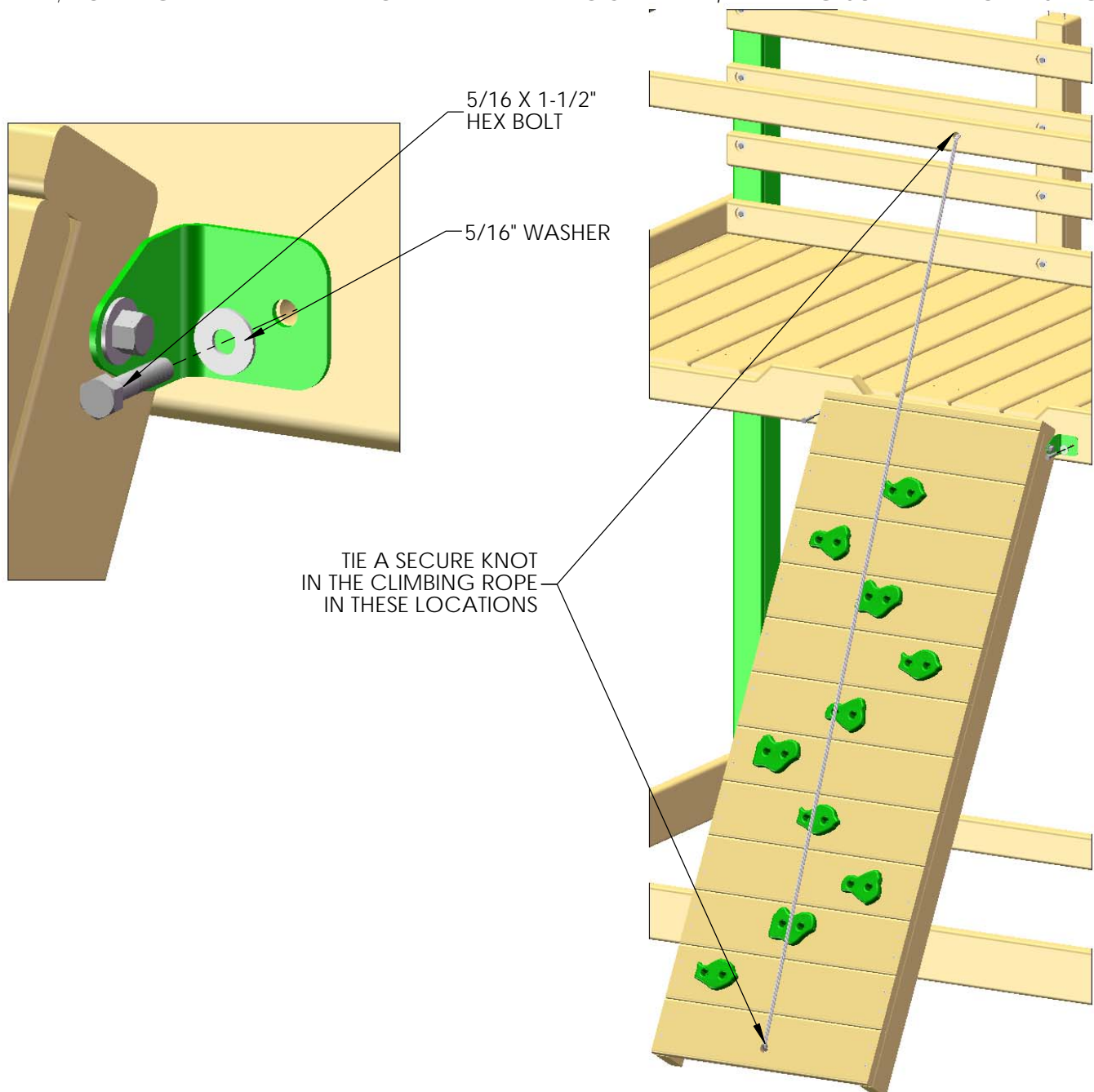

STEP 16: LADDER

1: FIND TWO 2 X 4 X 66" LADDER SIDES.

2: POSITION THE LADDER SIDES SO THAT THE SLOTS IN THE BOARDS ARE FACING EACH OTHER AND ARE PARALLEL.

3: INSERT T-NUTS INTO THE OUTSIDE OF THE LADDER SIDES AND SET WITH A HAMMER.

2 X 4 X 66"
LADDER SIDE

T-NUT

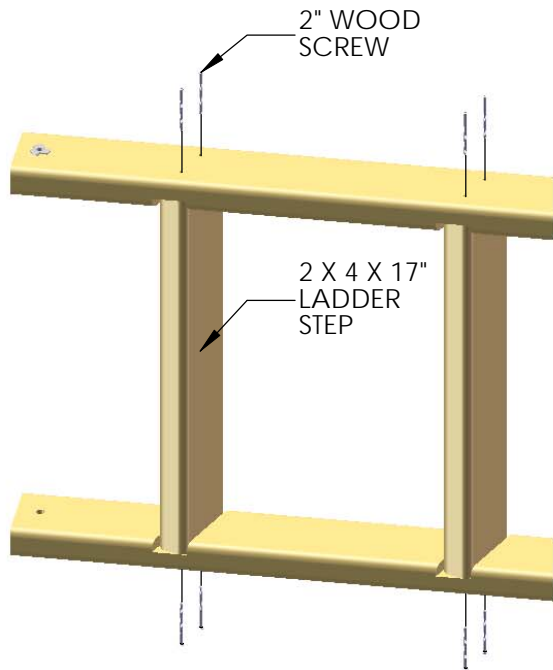
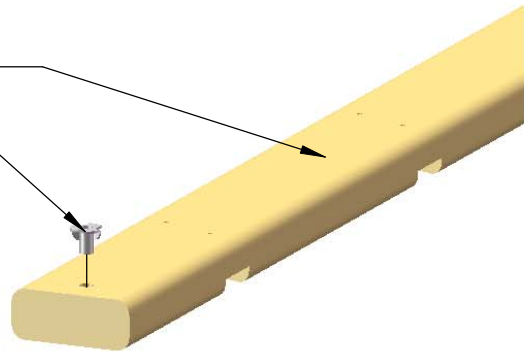

2" WOOD
SCREW

2 X 4 X 17"
LADDER
STEP

4: FIND FIVE 2 X 4 X 17" LADDER STEPS.

5: PLACE THE STEPS INTO THE SLOTS ON THE LADDER SIDES, AND FASTEN WITH 2" WOOD SCREWS.

6: CAREFULLY TURN THE LADDER OVER AND PUT THE SCREWS INTO THE OTHER SIDE.

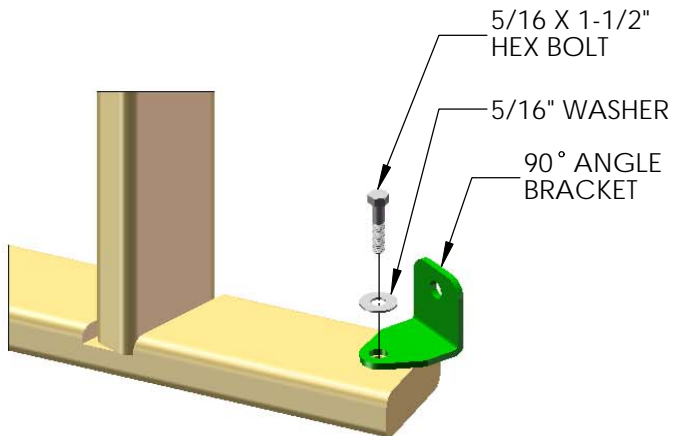

5/16 X 1-1/2"
HEX BOLT

5/16" WASHER

90° ANGLE
BRACKET

7: INSTALL THE 90° ANGLE BRACKETS TO THE INSIDE OF THE LADDER RAILS WITH 5/16 X 1-1/2" BOLTS, 5/16 WASHERS, INTO THE 5/16" T-NUTS.

8: INSTALL THE 5/4 X 3 X 18-3/4" LADDER BACK ABOVE THE TOP STEP OF THE LADDER WITH TWO 2" WOOD SCREWS PER SIDE.

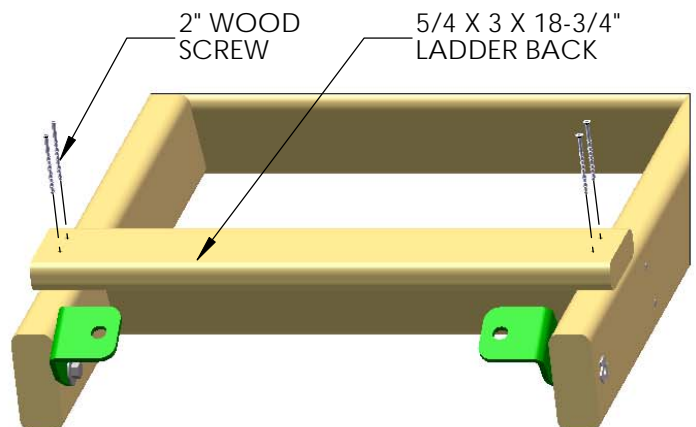

2" WOOD
SCREW

5/4 X 3 X 18-3/4"
LADDER BACK

STEP 17: ATTACHING THE LADDER TO THE FORT

1: CENTER THE LADDER ASSEMBLY TO THE OPENING ON THE LEFT SIDE OF THE FORT.

2: MOUNT THE LADDER TO THE OPENING. ALIGN BRACKETS 1/2" UP FROM THE BOTTOM OF THE 2 X 6 BOTTOM PANEL BOARD. MARK AND DRILL TWO 3/8" HOLES. INSTALL TWO 5/16" T-NUTS ON THE BACK SIDE OF THE BOARD. INSTALL THE LADDER WITH TWO 5/16 X 1-1/2" BOLTS AND 5/16" WASHERS INTO THE T-NUTS.

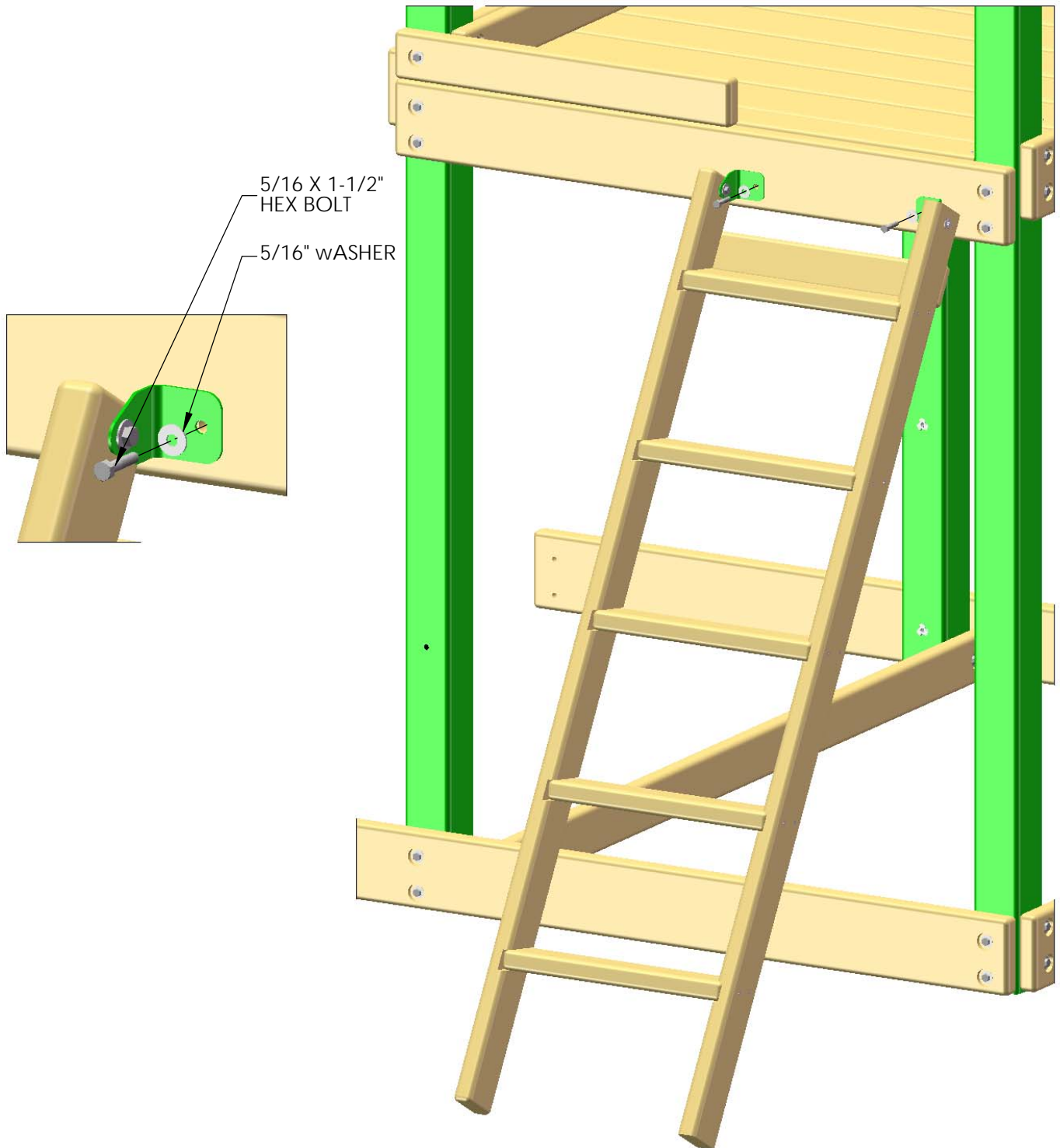

STEP 18: LAG POSTS

1: MAKE SURE THAT THE T-NUTS FROM STEP #1 ARE INSTALLED IN THE HOLES AT 95-1/2" ON THE MIDDLE CORNER POSTS.

2: PLACE THE RIGHT HAND CORNER LAG POST ON TOP OF THE BACK PANEL BOARD ON THE SWING BEAM SIDE OF THE FORT AND THE LEFT HAND CORNER LAG POST ON THE OPPOSITE SIDE OF THE FORT. MAKE SURE THE CORNER LAG POSTS ARE FLUSH TO THE CORNER POSTS AND ATTACH WITH 3/8 X 5" LAG SCREWS AND 3/8" WASHERS AS SHOWN BELOW.

3: MEASURE DOWN FROM THE TOP OF THE CENTER POST 6-3/4" AND MARK THIS POINT. THE BOTTOM OF THE CENTER LAG POST WILL ALIGN WITH THIS POINT. INSTALL THE POST WITH 3/8 X 5" LAG SCREWS AND 3/8" WASHERS.

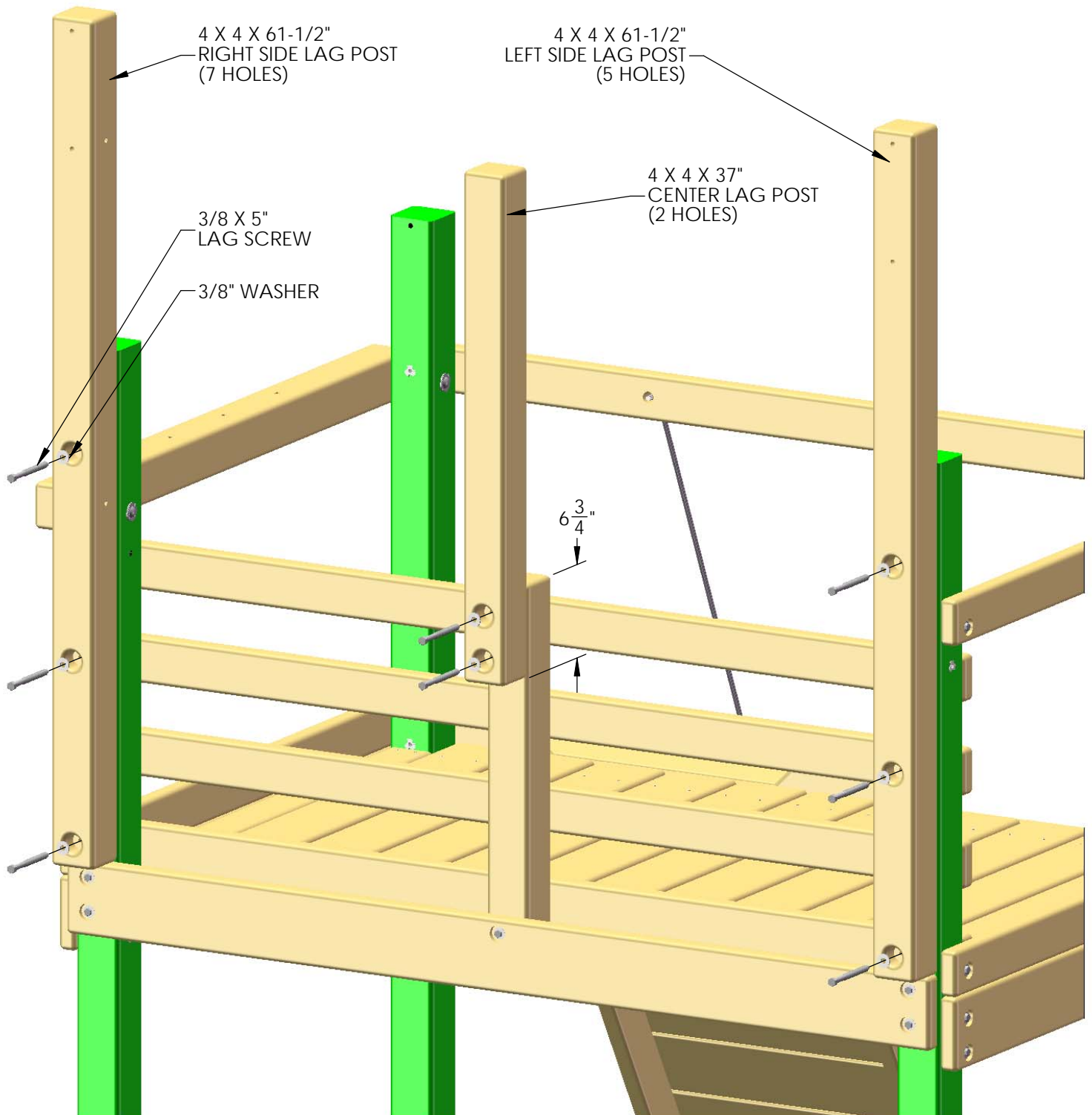

STEP 19: UPPER DECK SUPPORTS

1: FIND THE TWO 2 X 4 X 34" TOP LEVEL DECK SUPPORTS.

2: ATTACH THE TOP LEVEL DECK SUPPORTS TO THE MIDDLE CORNER POSTS FROM THE INSIDE THROUGH THE HOLES AT 81" WITH 5/16 X 4-1/2" HEX BOLTS AND 5/16" WASHERS.

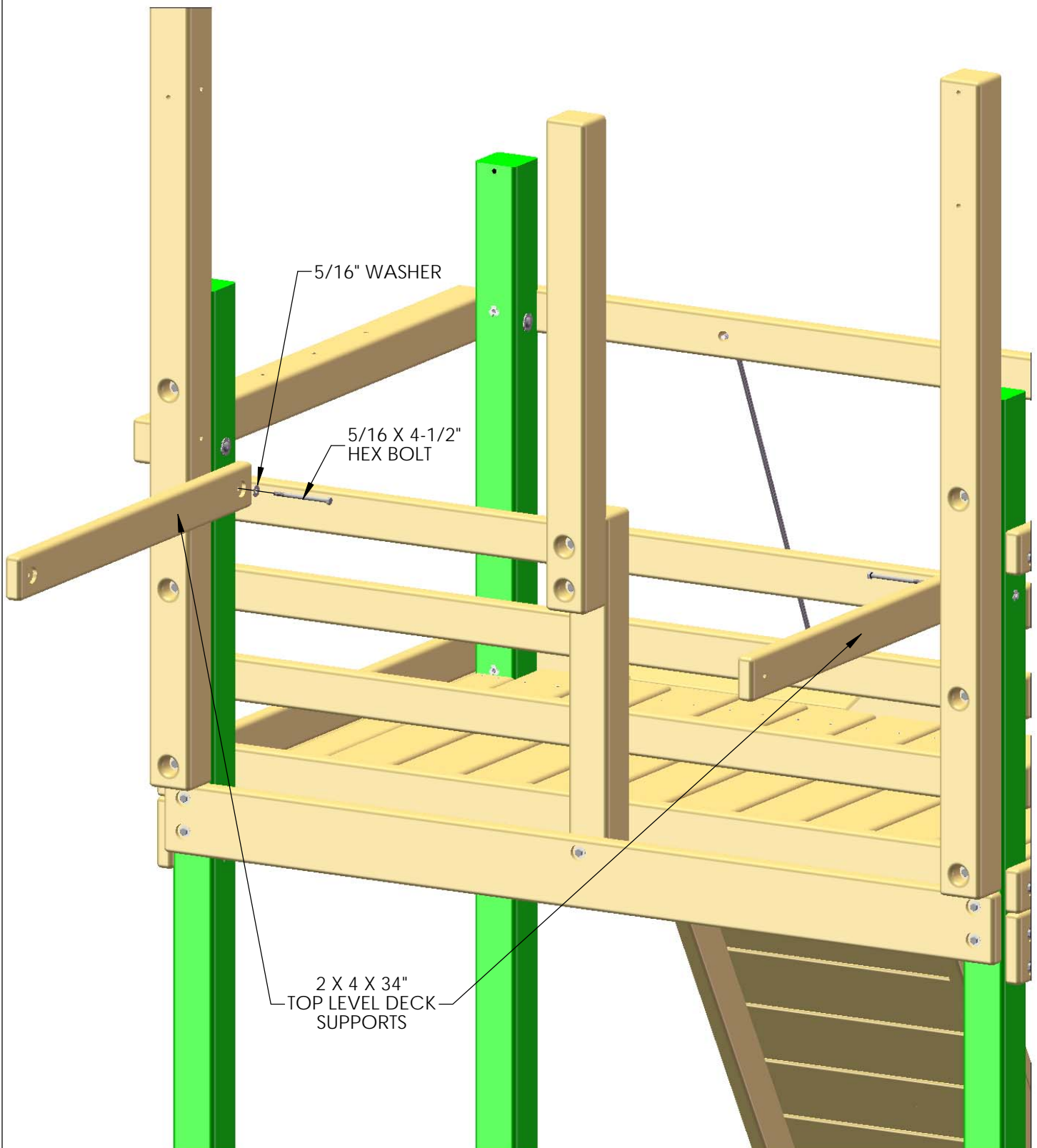

STEP 20: REAR CORNER POST T-NUTS

1: INSERT T-NUTS INTO THE HOLES AS SHOWN BELOW AND SET WITH A HAMMER, FLUSH TO THE SURFACE OF THE CORNER POSTS.

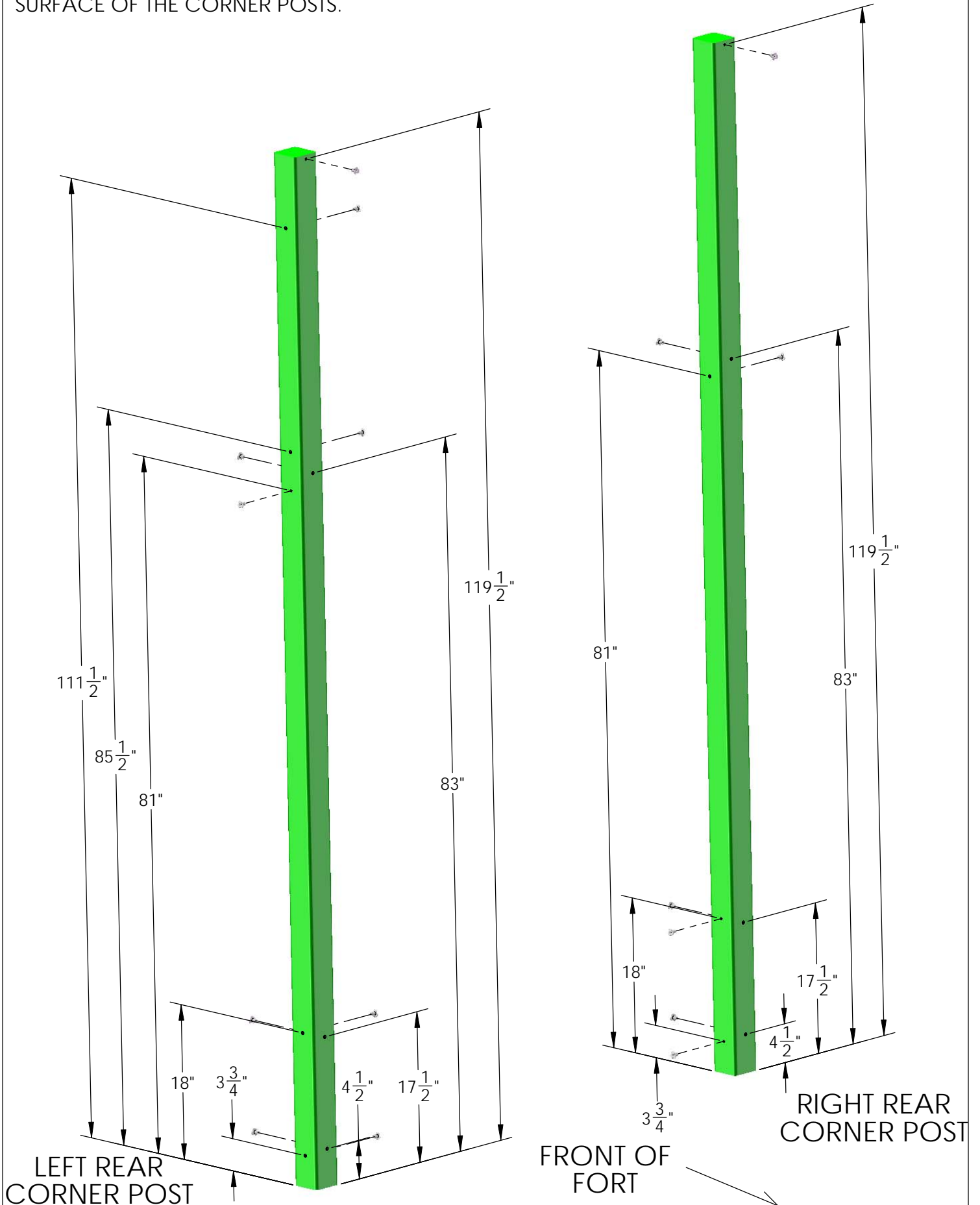

STEP 21: REAR CORNER POSTS

1: ATTACH THE BACK CORNER POSTS TO THE 78" SANDBOX BOARDS WITH 5/16 X 4-1/2" HEX BOLTS AND WASHERS THROUGH THE TOP HOLE OF THE SANDBOX BOARD, THROUGH THE HOLE AT 3-3/4" ON THE CORNER POST, INTO THE T-NUT ON THE BACK SIDE.

2: ATTACH THE POSTS TO THE 2 X 4 X 34" TOP LEVEL DECK SUPPORTS WITH 5/16 X 4-1/2" HEX BOLTS AND 5/16" WASHERS FROM THE INSIDE THROUGH THE 2 X 4, THROUGH THE HOLES AT 81", INTO THE T-NUT ON THE OUTSIDE.

3: INSERT A 5/16 X 3-1/2" LAG SCREW AND 5/16" WASHER INTO THE BOTTOM HOLE OF THE SANDBOX BOARDS.

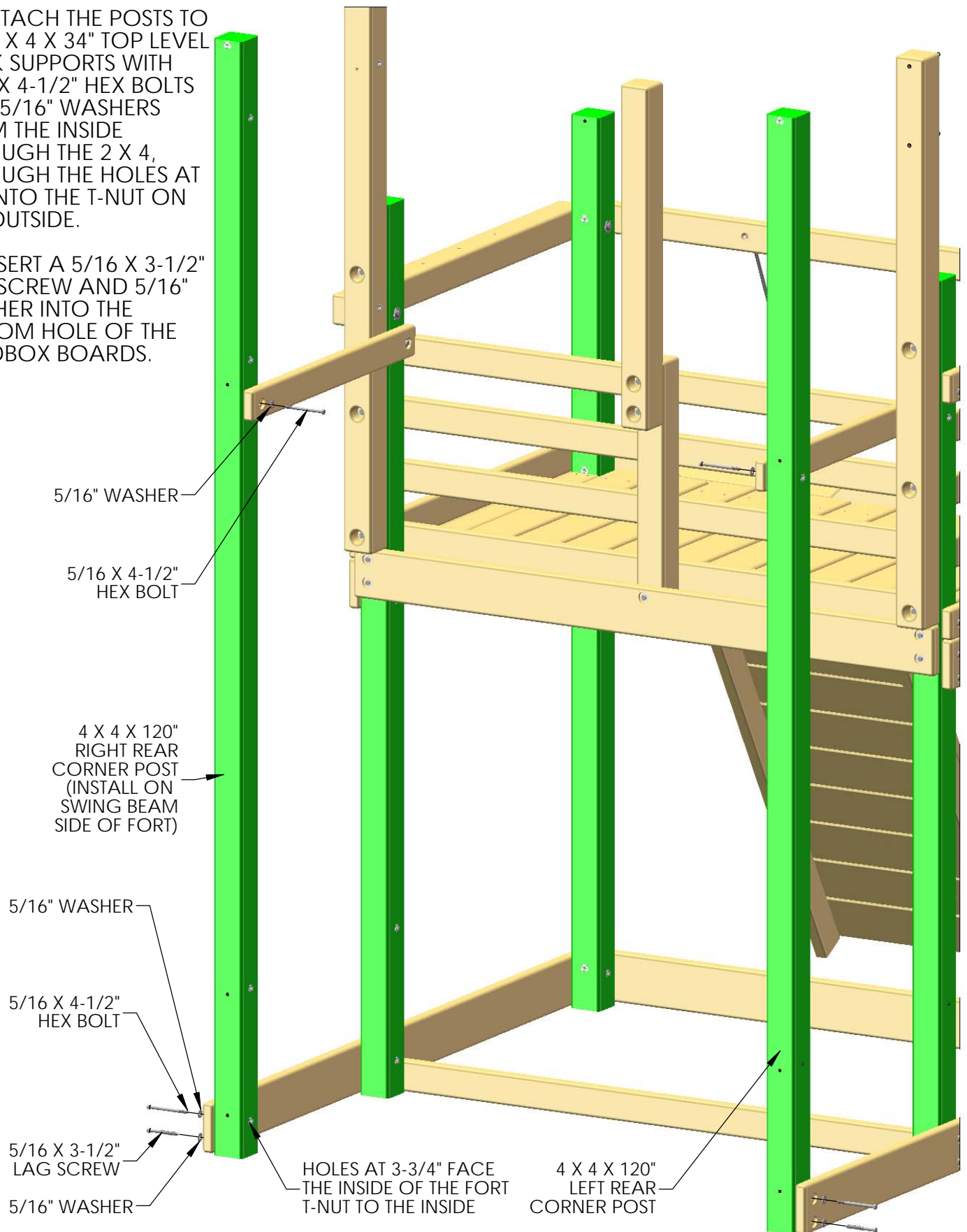

STEP 22: BACK PANEL BOARD

1: ATTACH THE 2 X 6 X 70" REAR BOTTOM PANEL BOARD TO THE REAR CORNER POST WITH OFFSET HOLES DOWN WITH TWO 5/16 X 4-1/2" HEX BOLTS AND 5/16" WASHERS THROUGH THE BOTTOM HOLES OF THE BACK PANEL BOARD, THROUGH THE HOLES AT 83", INTO THE T-NUTS ON THE BACK SIDE. INSERT 5/16 X 3-1/2" LAG SCREWS AND 5/16" WASHERS THROUGH THE TOP HOLES OF THE BACK PANEL BOARD.

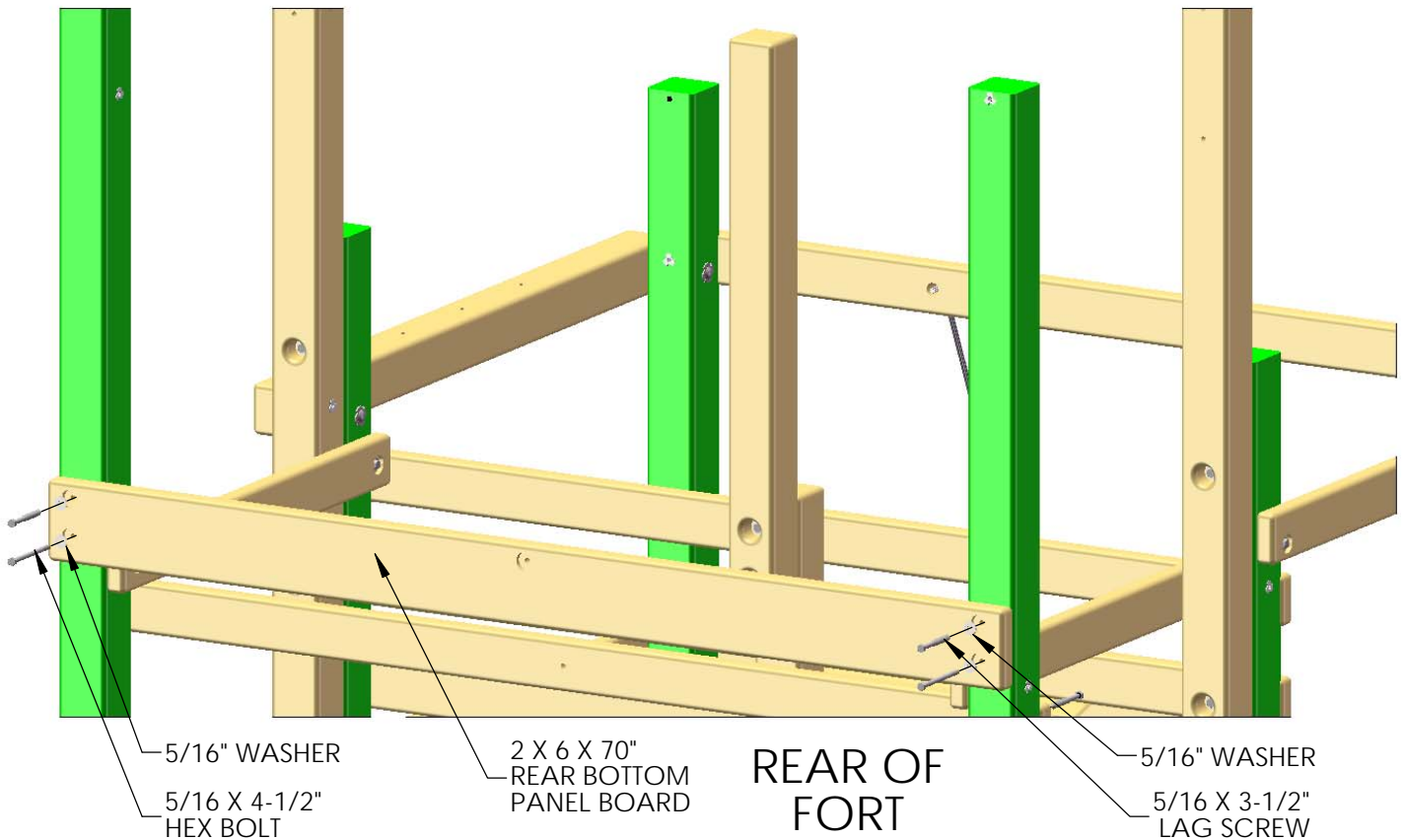

2: PLACE THE 2 X 4 X 70" 3-HOLE FLUSH TO THE BOTTOM OF THE TOP LEVEL DECK SUPPORTS AND THE REAR CORNER POSTS. ATTACH IT WITH TWO 5/16 X 3-1/2" LAG SCREWS AND 5/16" WASHERS.

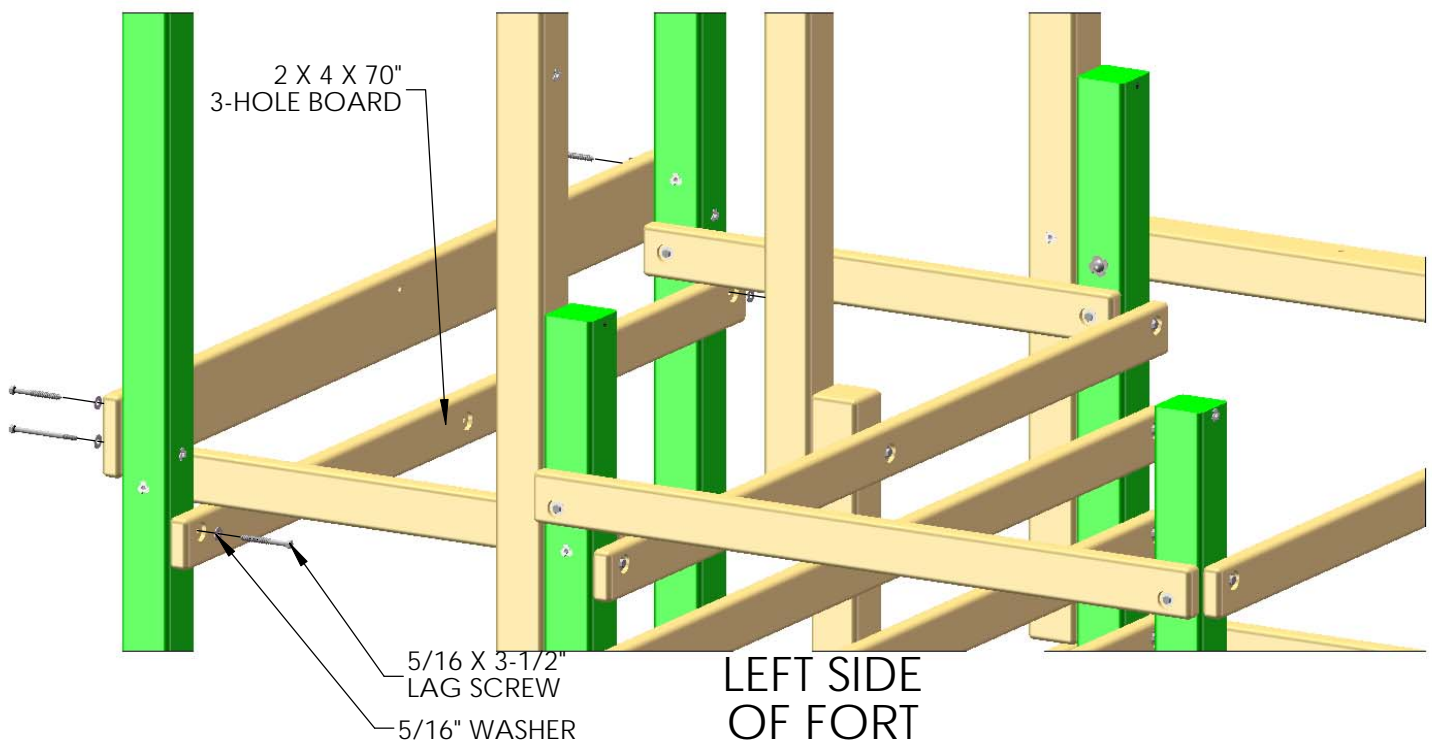

STEP 23: TOP LEVEL REAR CENTER POST

1: INSTALL A T-NUT ON THE OUTSIDE OF THE TOP LEVEL REAR CENTER POST. ATTACH THE 2 X 4 X 70" 3 HOLE TO THE 4 X 4 X 37" TOP LEVEL REAR CENTER POST WITH A 5/16 X 4-1/2" HEX BOLT AND 5/16" WASHER FROM THE INSIDE THROUGH THE 2 X 4, INTO THE T-NUT.

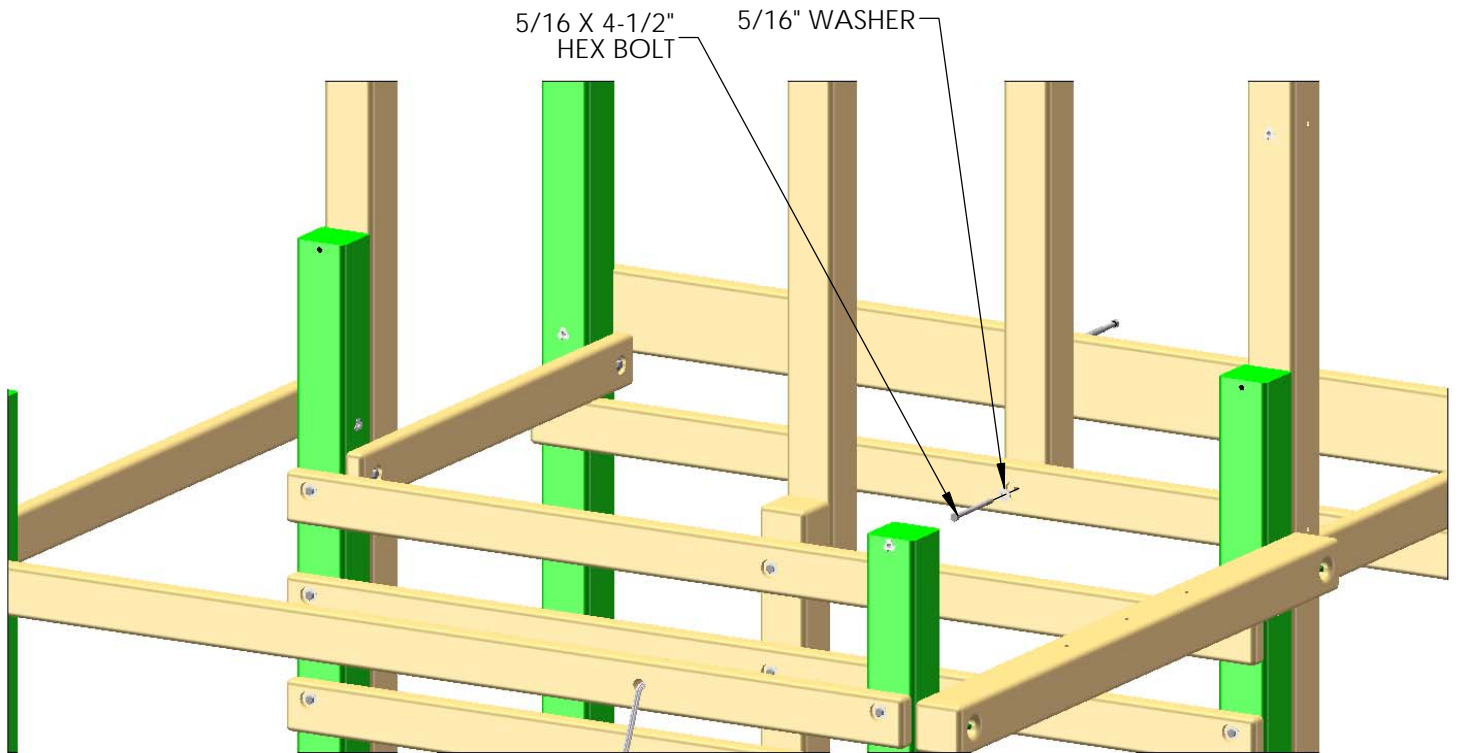

2: MAKE SURE THE CENTER POST IS SQUARE AND ATTACH WITH A 5/16 X 3-1/2" LAG SCREW WITH 5/16" WASHER THROUGH THE CENTER HOLE OF THE TOP LEVEL REAR PANEL BOARD.

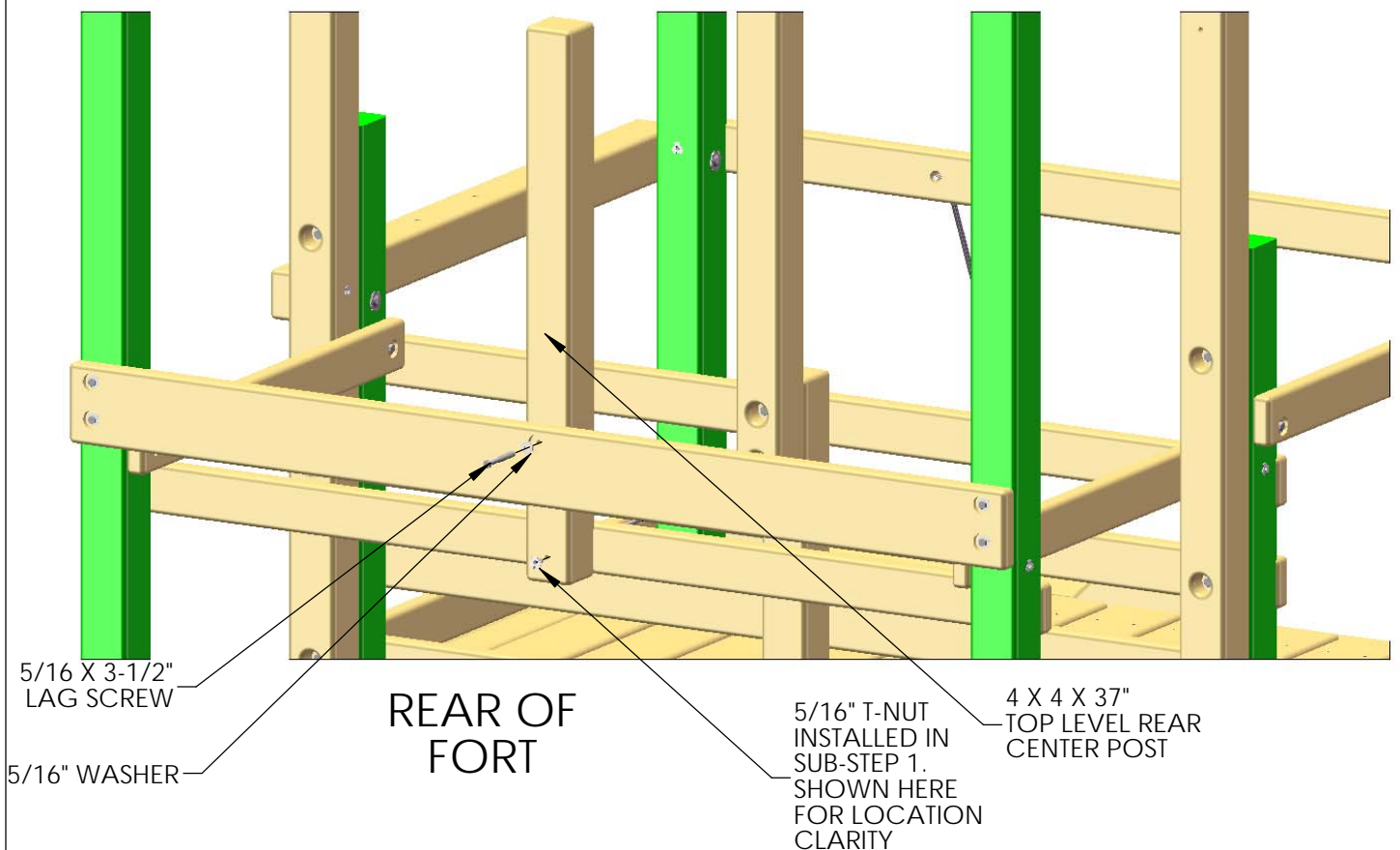

STEP 24: TOP LEVEL CENTER DECK SUPPORT

1: ATTACH THE 2 X 4 X 30-3/4" CENTER DECK SUPPORTS TO THE CENTER POST WITH 5/16 X 3-1/2" LAG SCREWS AND 5/16" WASHERS.

NOTE: THE OFFSET HOLES MUST BE UP ON ONE SIDE AND DOWN ON THE OTHER TO PREVENT INTERFERENCE.

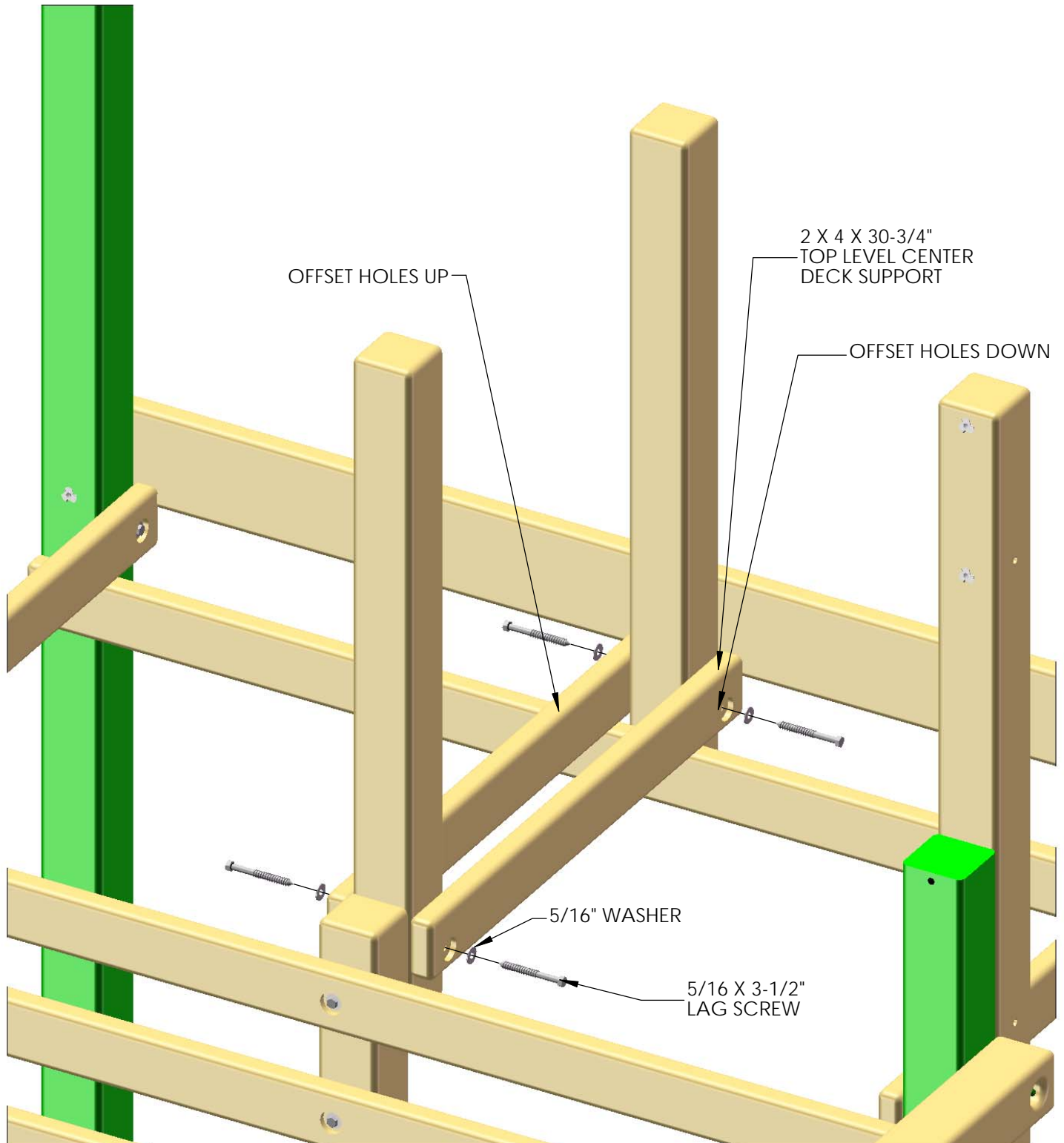

STEP 25: PORCH DECK SUPPORTS

1: ATTACH THE TWO 2 X 4 X 34" PORCH DECK SUPPORTS FLUSH TO THE BOTTOM OF THE REAR CORNER POSTS WITH 5/16 X 3-1/2" LAG SCREWS AND 5/16" WASHERS.

2: ATTACH THE 2 X 6 X 70" SANDBOX BOARD TO THE REAR CORNER POSTS WITH 5/16 X 4-1/2" HEX BOLTS AND 5/16" WASHERS THROUGH THE TOP HOLES OF THE SANDBOX BOARD OFFSET UP, THROUGH THE HOLES AT 4-1/2". INSERT 5/16 X 3-1/2" LAG SCREWS AND 5/16" WASHERS THROUGH THE BOTTOM HOLES OF THE SANDBOX BOARD.

3: FIND THE CENTER OF THE SANDBOX BOARD AND MARK THIS POSITION. CENTER THE 2 X 4 X 34" PORCH CENTER DECK SUPPORT ON THE MARK AND ATTACH IT WITH TWO 2-1/2" WOOD SCREWS ON EACH END THROUGH THE OUTSIDE OF THE SANDBOX BOARD AND INTO THE END OF THE 2 X 4.

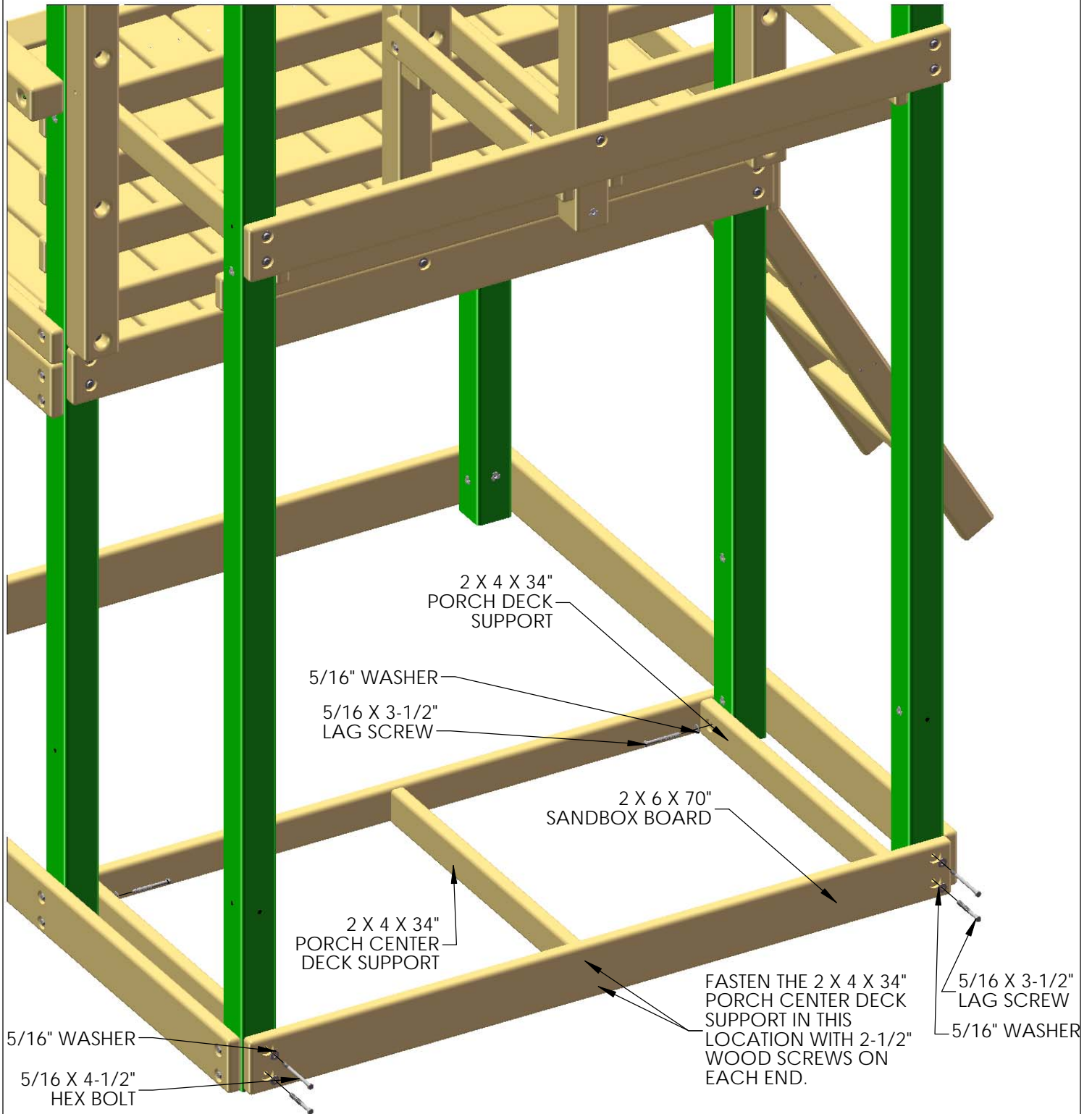

STEP 26: PORCH DECK

1: DRILL HOLES IN THE BOARDS ON EACH SIDE AS SHOWN BELOW WITH A 1/8" DRILL BIT TO PREVENT INSTALLATION DAMAGE. THE HOLES AT 31-3/8" AND 34-15/16" ARE THE CENTER HOLES AND ONLY NEED TO BE DRILLED ONCE.

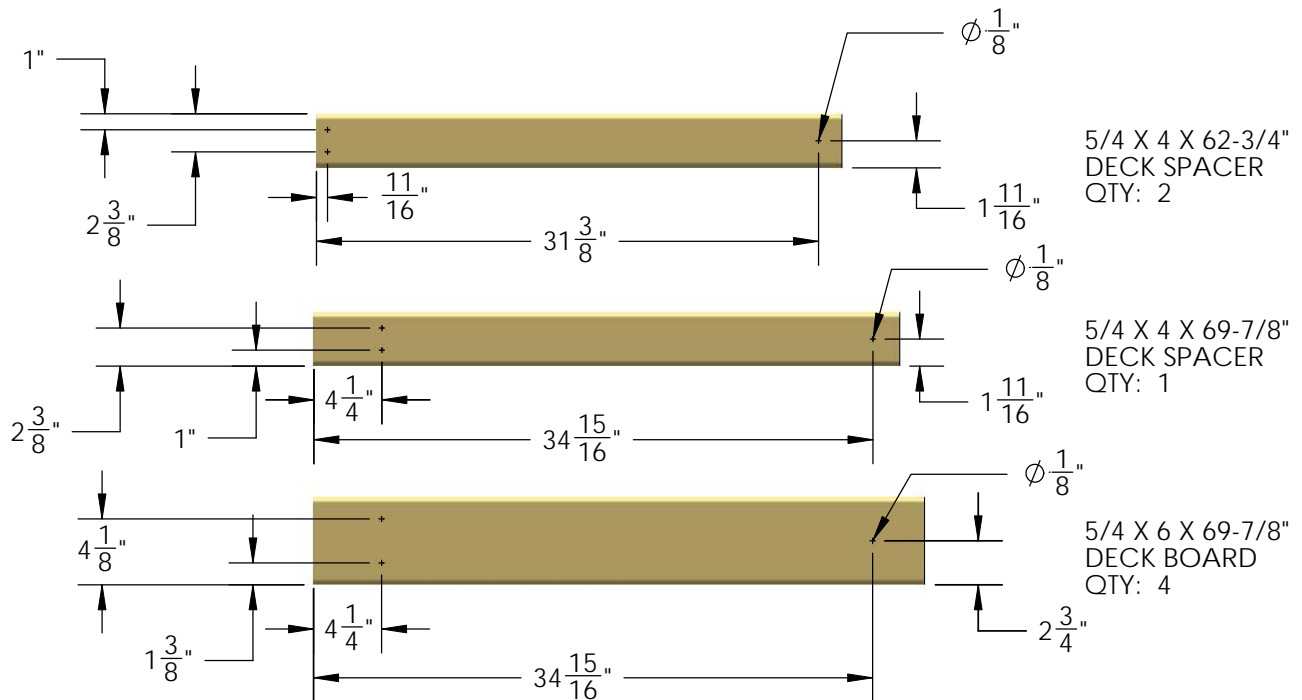

2: PLACE THE DECK SPACERS BETWEEN THE CORNER POST AND ON TOP OF THE PORCH DECK SUPPORTS. ATTACH WITH 2" WOOD SCREWS PER SIDE THROUGH THE HOLES DRILLED IN THE PART.

3: PLACE THE FOUR DECK BOARDS AND ONE LOWER DECK SPACER ACROSS THE TOP OF THE PORCH DECK SUPPORTS. EVENLY SPACE THESE BOARDS AND ATTACH THEM WITH TWO 2" WOOD SCREWS PER SIDE THROUGH THE HOLES DRILLED IN THE PART.

4: ATTACH THE DECK BOARDS TO THE PORCH CENTER DECK SUPPORT WITH 2" WOOD SCREWS.

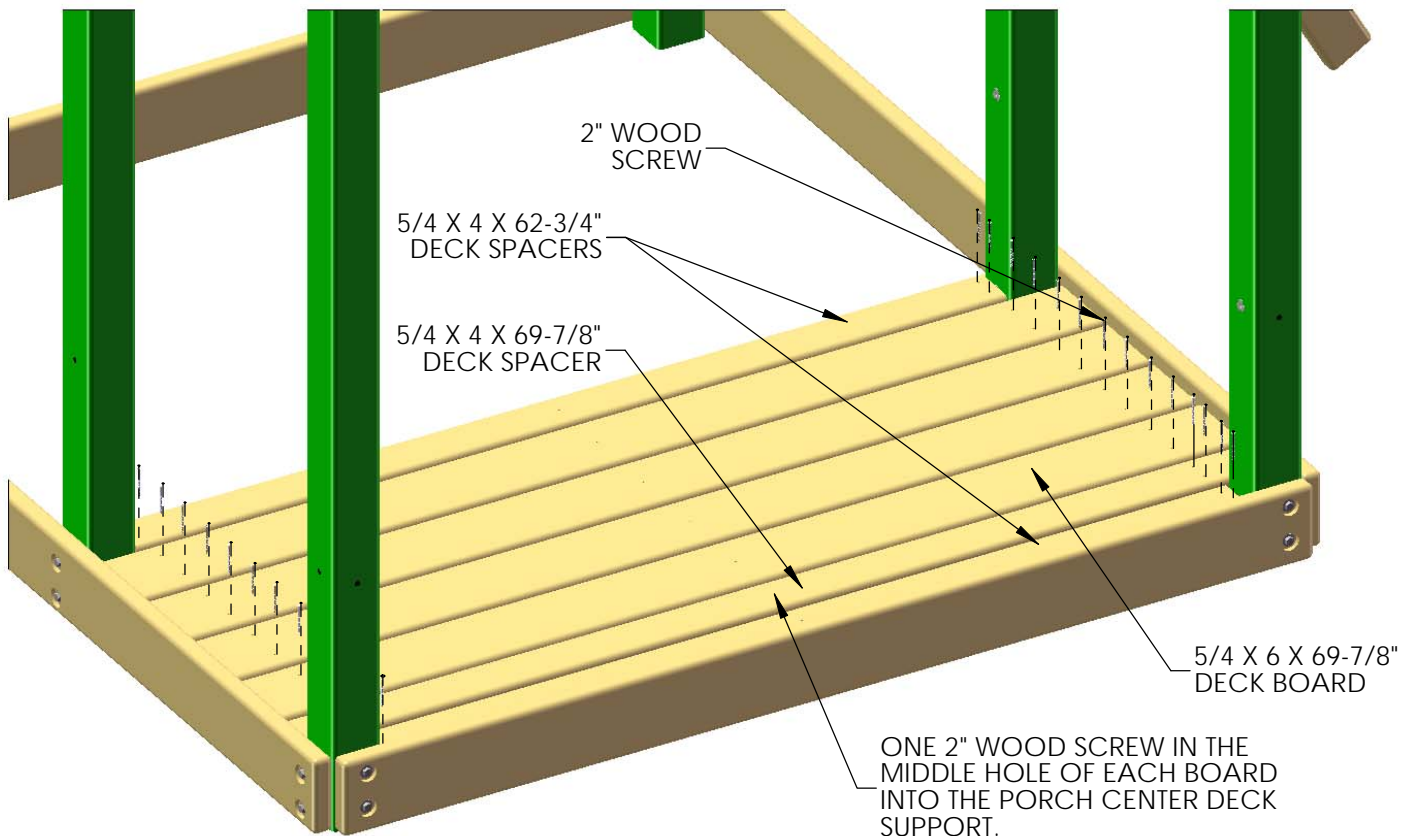

STEP 27: PORCH RAILS

1: ATTACH THE 2 X 4 X 34" PORCH SIDE TOP PANEL BOARDS WITH THE HOLES OFFSET DOWN WITH 5/16 X 4-1/2" HEX BOLTS AND 5/16" WASHERS THROUGH THESE HOLES AND THE HOLES AT 18" ON THE MIDDLE CORNER POSTS.

2: ATTACH THE 2 X 4 X 70" PORCH TOP PANEL BOARD TO THE REAR CORNER POSTS WITH HOLES OFFSET DOWN WITH 5/16 X 4-1/2" HEX BOLTS AND 5/16" WASHERS THROUGH THESE HOLES.

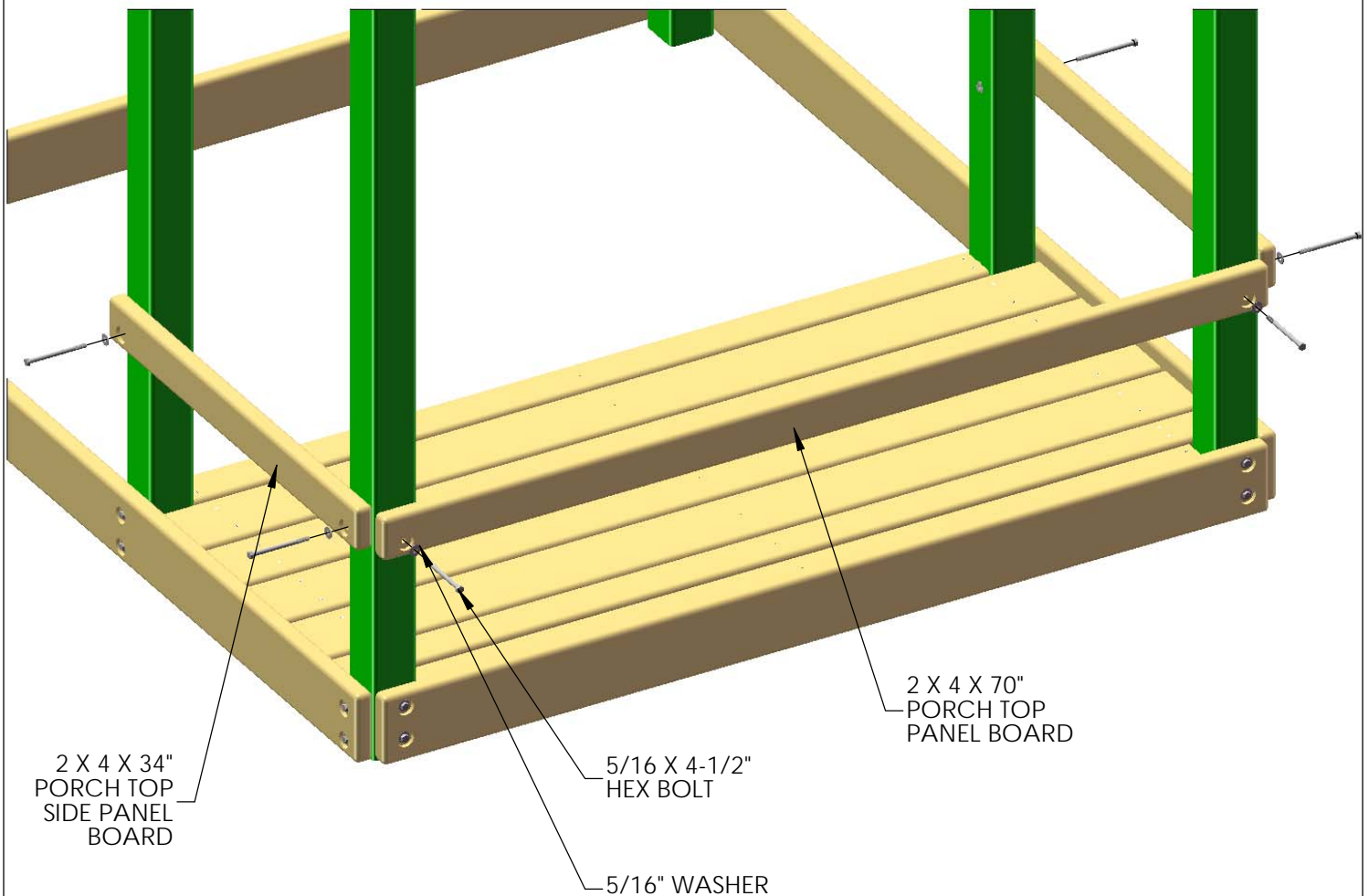

STEP 28: PORCH PANEL SLATS

1: PREDRILL EACH BOARD 1/2" FROM EACH END ON CENTER WITH A 1/8" DRILL BIT.

2: THE SLATS WILL BE POSITIONED ON TOP OF THE DECK BOARDS BETWEEN THE PORCH TOP PANEL BOARDS AND THE SANDBOX BOARDS. THEY SHOULD BE SPACED BETWEEN THE CORNER POSTS USING A SLAT AS A SPACER (2-5/8"). ATTACH THE SLATS TO THE TOP PANEL BOARDS AND SANDBOX BOARDS WITH 2" WOOD SCREWS THROUGH THE HOLES.

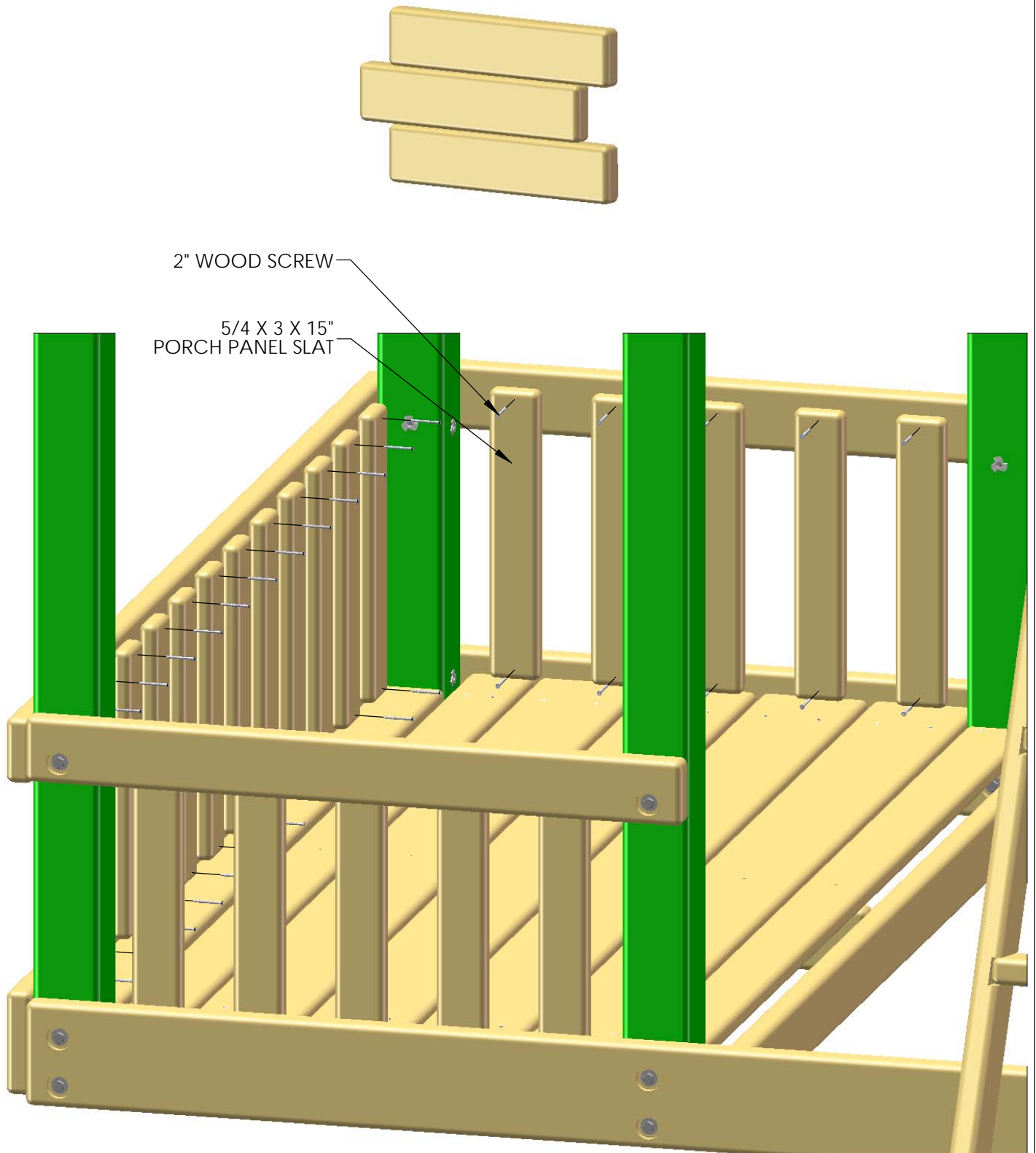

STEP 29: TOP LEVEL SIDE BOTTOM PANEL BOARD

- 1: INSERT A 5/16" T-NUT INTO THE HOLE AT 26-1/4" FROM THE BOTTOM OF THE RIGHT HAND CORNER LAG POST.
- 2: ATTACH THE 30-3/4" BOTTOM PANEL BOARD WITH THE HOLES OFFSET UP WITH 5/16 X 4-1/2" HEX BOLTS AND 5/16" WASHERS THROUGH THE TOP HOLE, THROUGH THE BACK CORNER POST AND CORNER LAG POST, AND INTO T-NUTS INSTALLED.
- 3: PLACE A 5/16 X 3-1/2" LAG SCREW WITH A 5/16" WASHER INTO THE BOTTOM HOLES OF THE TOP LEVEL SIDE BOTTOM PANEL BOARD.

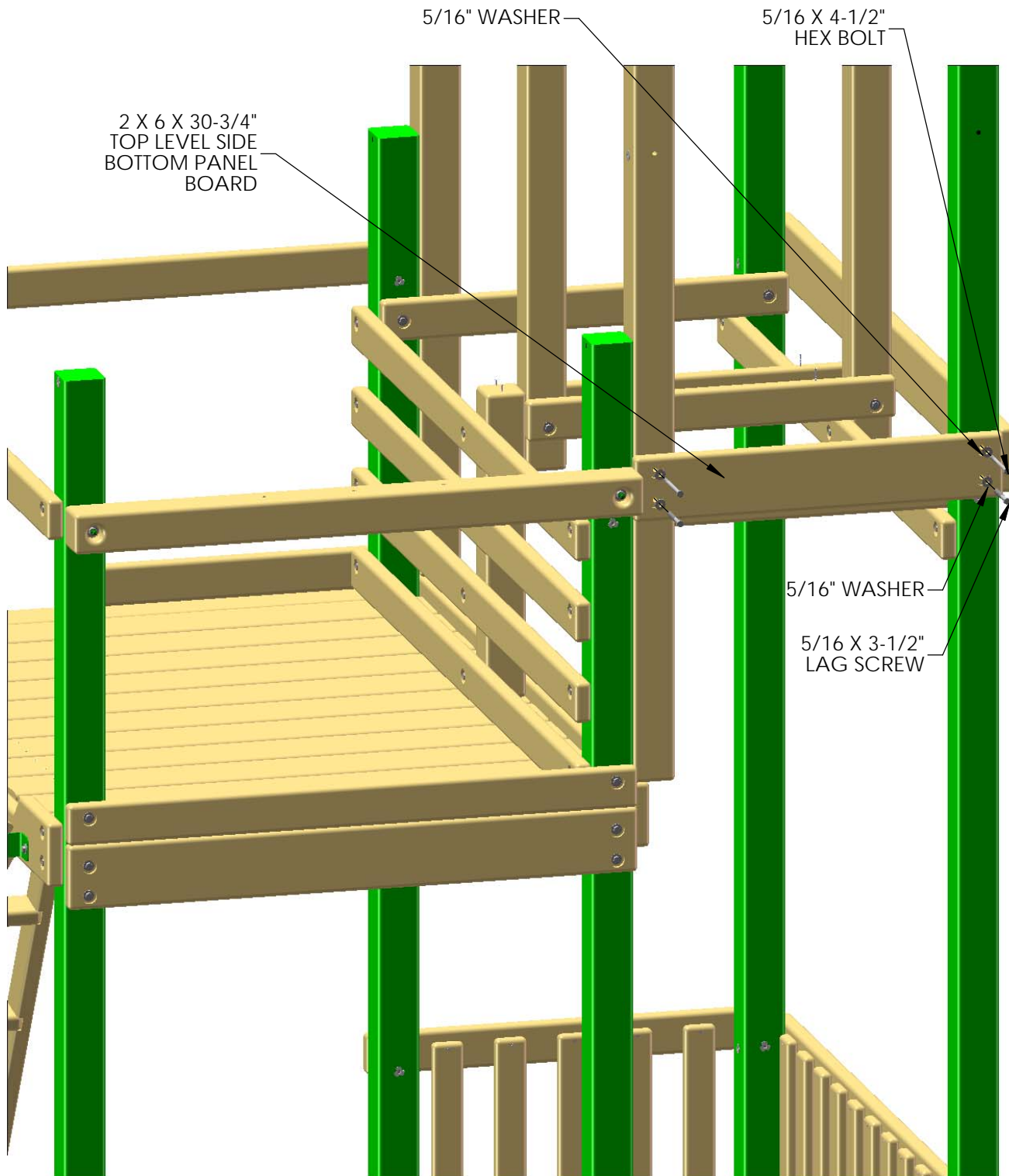

STEP 30: UPPER DECK

1: DRILL HOLES IN THE BOARDS ON EACH SIDE AS SHOWN BELOW WITH A 1/8" DRILL BIT TO PREVENT INSTALLATION DAMAGE.

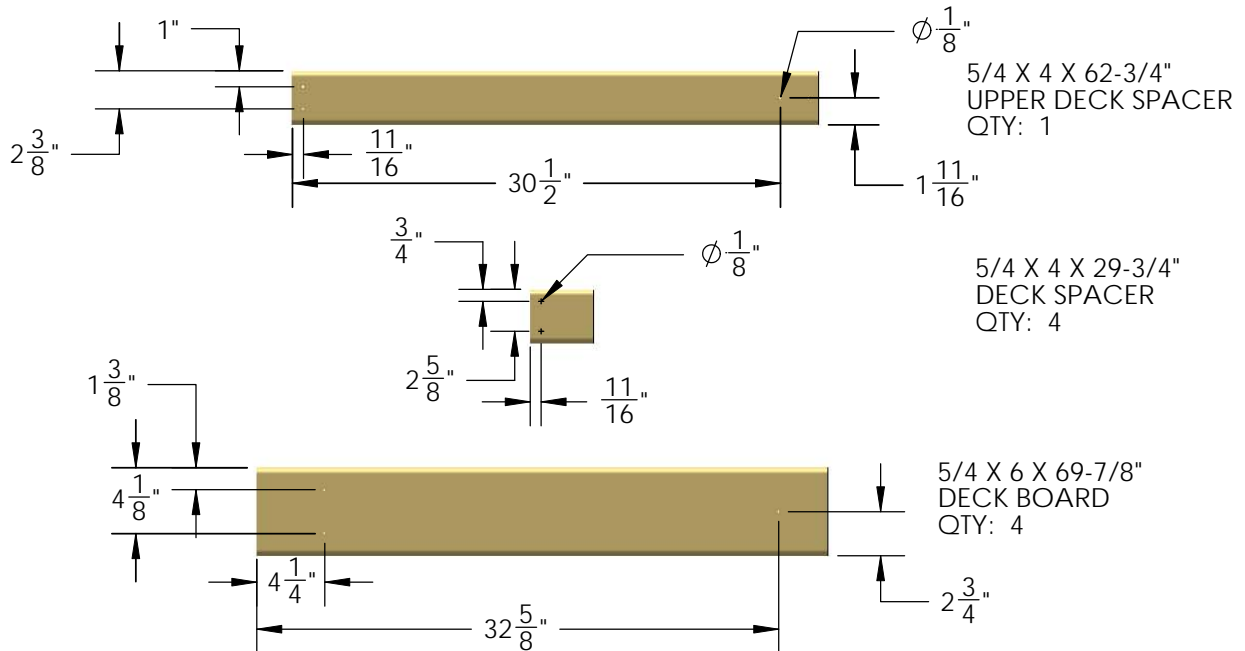

2: PLACE THE DECK SPACERS BETWEEN THE CORNER POSTS AND CENTER POSTS. ATTACH WITH 2" WOOD SCREWS PER SIDE THROUGH THE HOLES DRILLED IN THE PART.

3: PLACE THE FOUR DECK BOARDS ACROSS THE TOP OF THE UPPER DECK SUPPORTS. EVENLY SPACE THESE BOARDS AND ATTACH THEM WITH TWO 2" WOOD SCREWS PER SIDE THROUGH THE HOLES DRILLED IN THE PART.

4: ATTACH THE UPPER DECK SPACER BETWEEN THE MIDDLE CORNER POSTS AND IN FRONT OF THE CENTER LAG POST WITH 2" WOOD SCREWS.

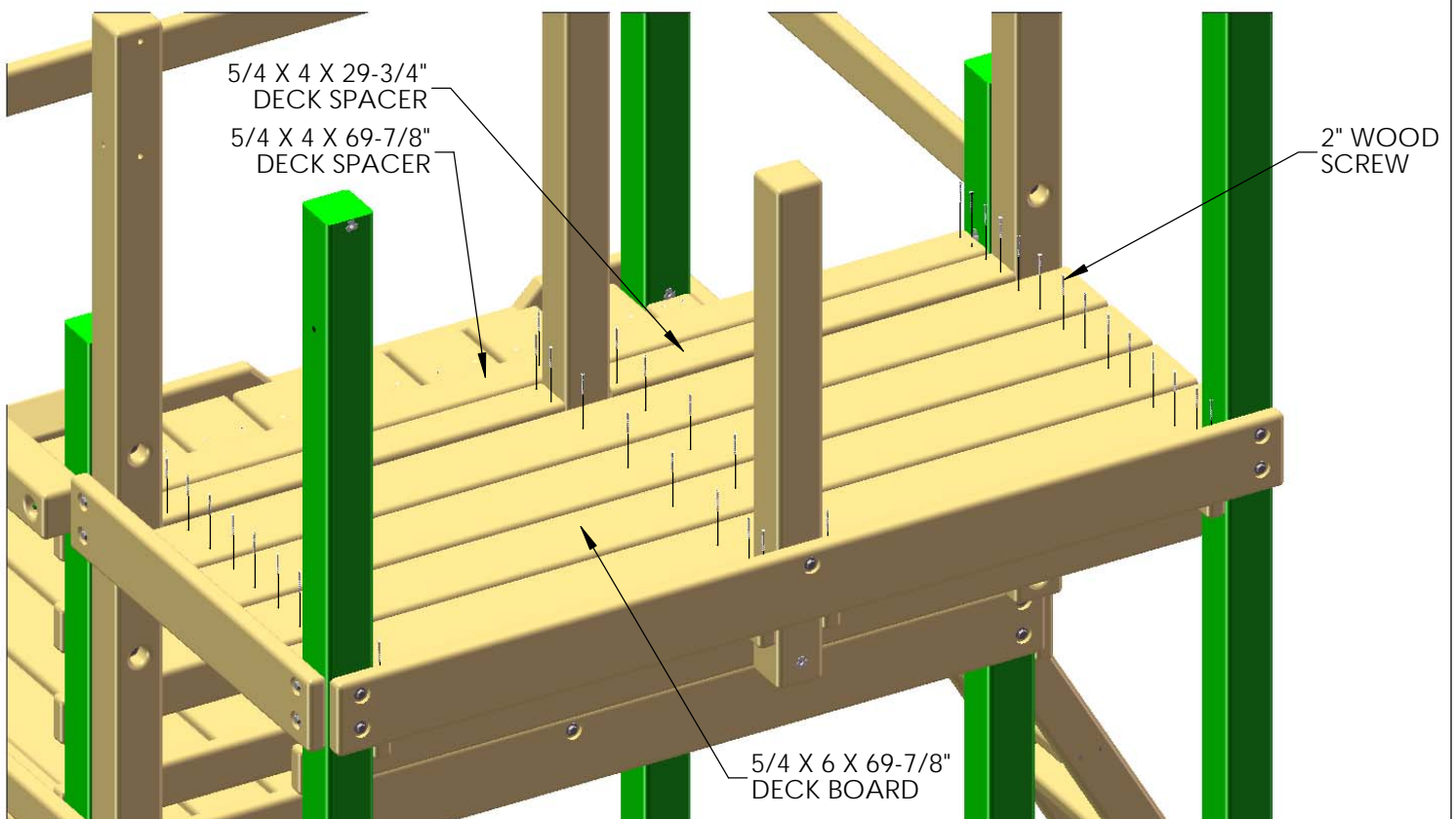

STEP 31: UPPER LEVEL TOP PANEL BOARDS

1: ATTACH THE 2 X 4 X 30-3/4" TOP LEVEL SIDE PANEL BOARD WITH HOLES OFFSET UP TO THE HOLE AT 111" ON THE RIGHT HAND BACK CORNER POST AND THE HOLE 9" FROM THE TOP OF THE RIGHT HAND CORNER LAG POST. USE 5/16 X 4-1/2" HEX BOLTS AND 5/16" WASHERS AND T-NUTS.

2: ATTACH ONE OF THE 2 X 4 X 70" 3-HOLE TOP PANEL BOARDS WITH THE HOLES OFFSET UP TO THE CORNER LAG POSTS THROUGH THE HOLES 9-1/2" FROM THE TOP. USE 5/16 X 4-1/2" HEX BOLTS AND 5/16" WASHERS AND T-NUTS. INSERT A 5/16 X 3-1/2" LAG SCREW WITH 5/16" WASHER THROUGH THE CENTER HOLE OF THE 70" 3-HOLE INTO THE CENTER LAG POST.

3: PLACE THE REMAINING 2 X 4 X 70" 3-HOLE TOP PANEL BOARD FLUSH TO THE END OF THE 2 X 4 X 30-3/4" AND THE OUTSIDE OF THE BACK CORNER POST. SET THE 3-HOLE LEVEL AND ATTACH IT TO BOTH BACK CORNER POSTS AND THE CENTER POST WITH 5/16 X 3-1/2" LAG SCREWS.

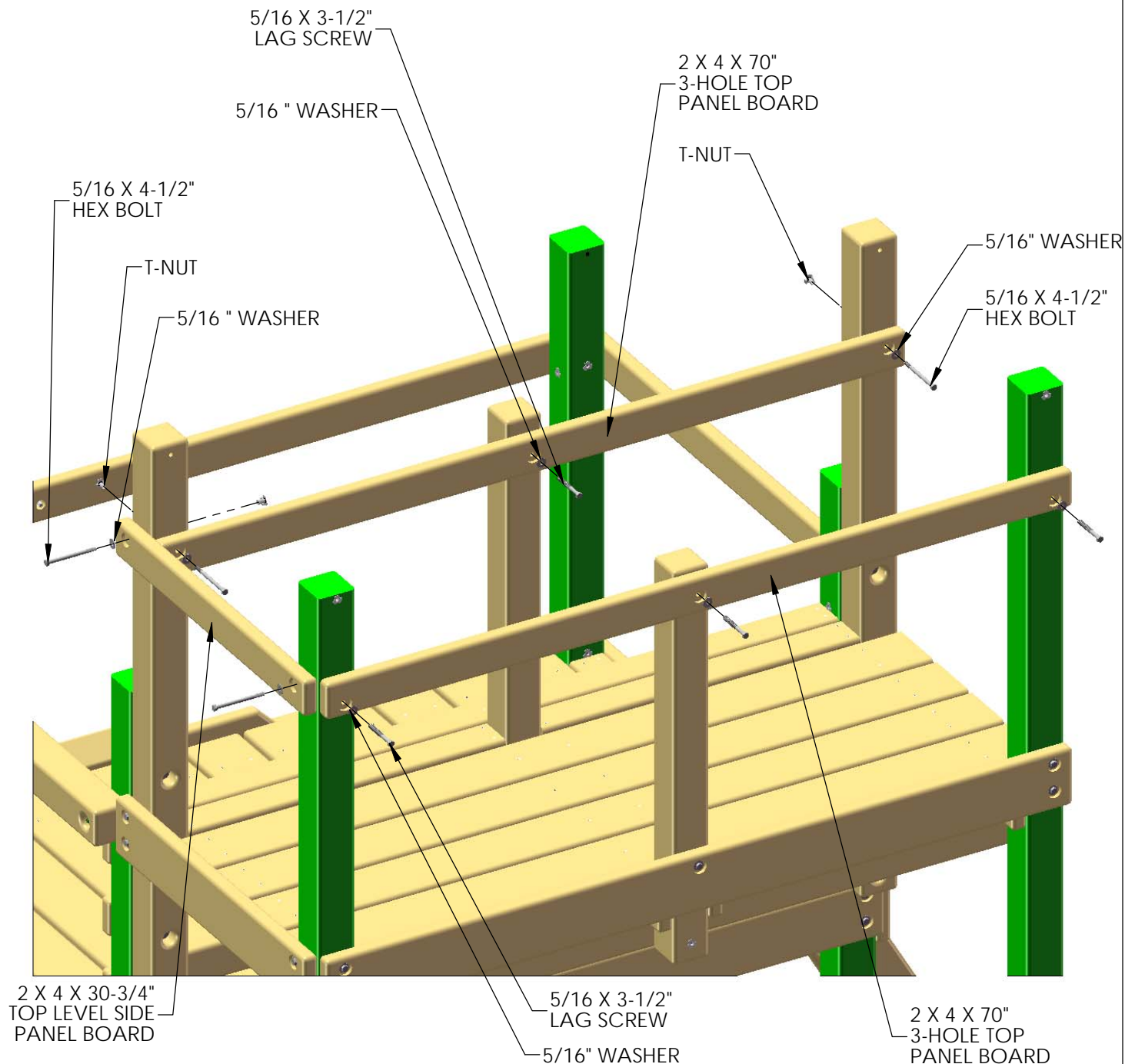

STEP 32: PANEL SLATS

1: YOU WILL NEED TO PREDRILL THE ENDS OF THE DECK BOARDS TO PREVENT INSTALLATION DAMAGE. PREDRILL BOTH ENDS WITH A 1/8" DRILL BIT USING THE DIMENSIONS BELOW.

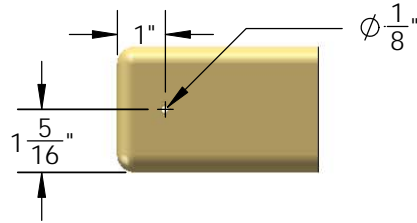

5/4 X 3 X 28"
PANEL SLAT

2: INSTALL THE PANEL SLATS BETWEEN THE DECK AND THE TOP PANEL BOARDS ON BOTH LEVELS OF THE FORT. EVENLY SPACE USING A SLAT AS A SPACER AS SHOWN BELOW. SECURE THE SLATS WITH 2" WOOD SCREWS.

3: INSTALL PANEL SLATS ONE SPACE IN FROM CORNER AND/OR CENTER POSTS. SLATS SHOULD NOT START NEXT TO CORNER OR CENTER POSTS

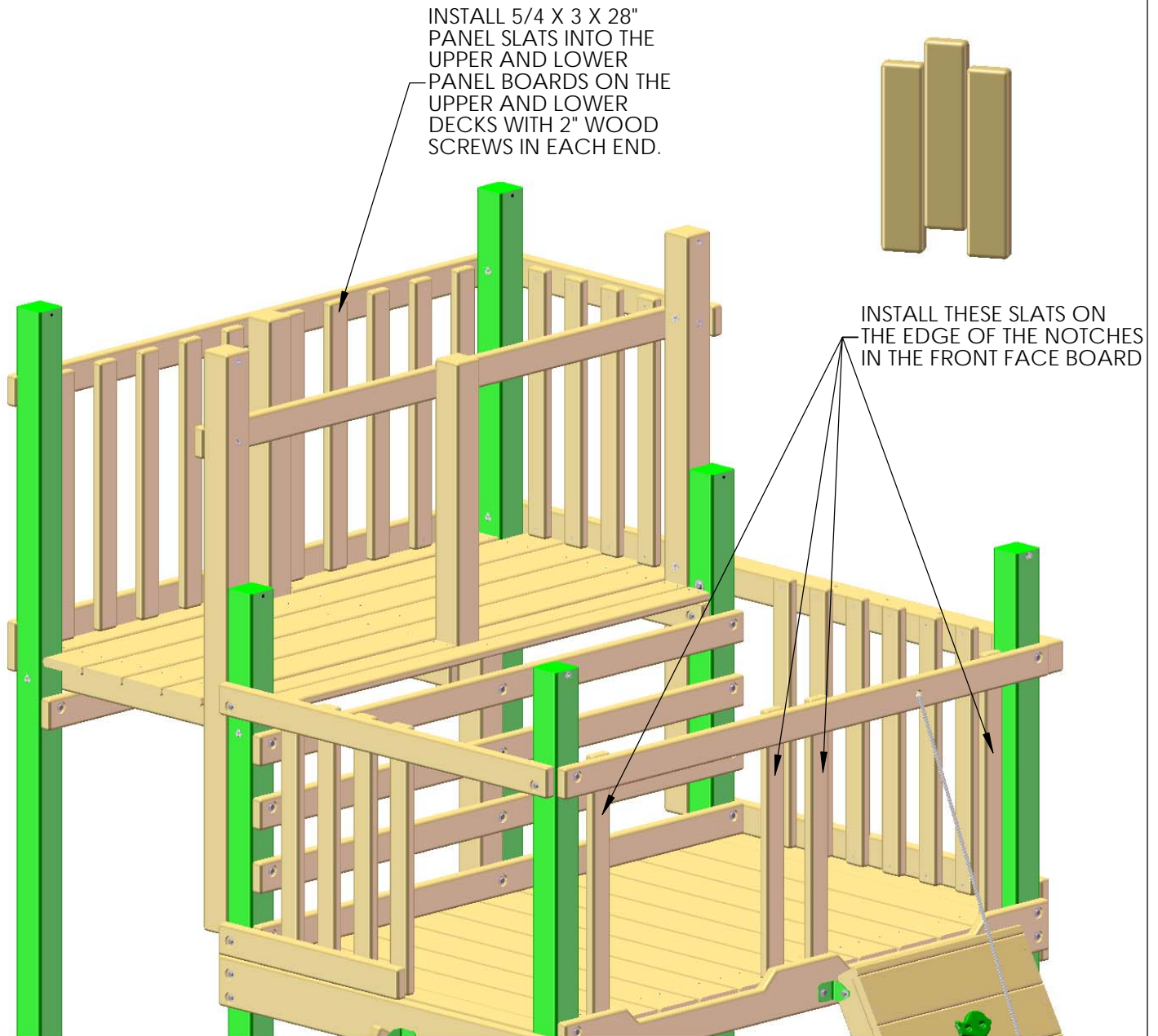

STEP 33: SWING BEAM PLATE

- 1: PLACE THE SWING BEAM PLATE ON TOP OF THE SWING BEAM SUPPORT, LINING UP THE PILOT HOLES.
- 2: FASTEN THE SWING BEAM PLATE TO THE SWING BEAM SUPPORT USING 3-1/2" CARRIAGE BOLTS WITH 1/2" WASHERS ON TOP, AND 3/8" LOCK NUTS WITH 3/8" WASHERS FROM UNDERNEATH, IN THE COUNTER-SUNK HOLES OF THE SWING BEAM SUPPORT. USE BOLT CAPS TO COVER ANY EXPOSED THREADS.
- 3: LEAVE THE MIDDLE HOLE EMPTY, IT WILL BE USED LATER.
- 4: USE VICE GRIPS TO HOLD CARRIAGE BOLTS IN PLACE WHEN INSTALLING.

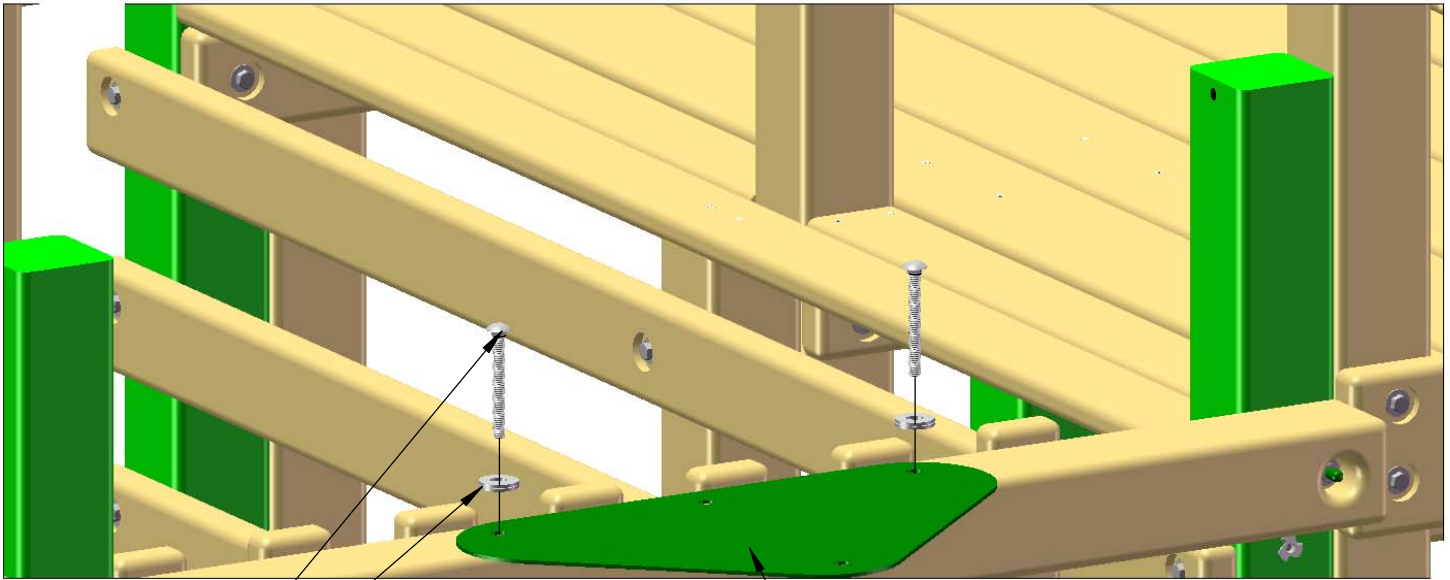

3-1/2" CARRIAGE
BOLT

1/2" WASHER

SWING BEAM PLATE

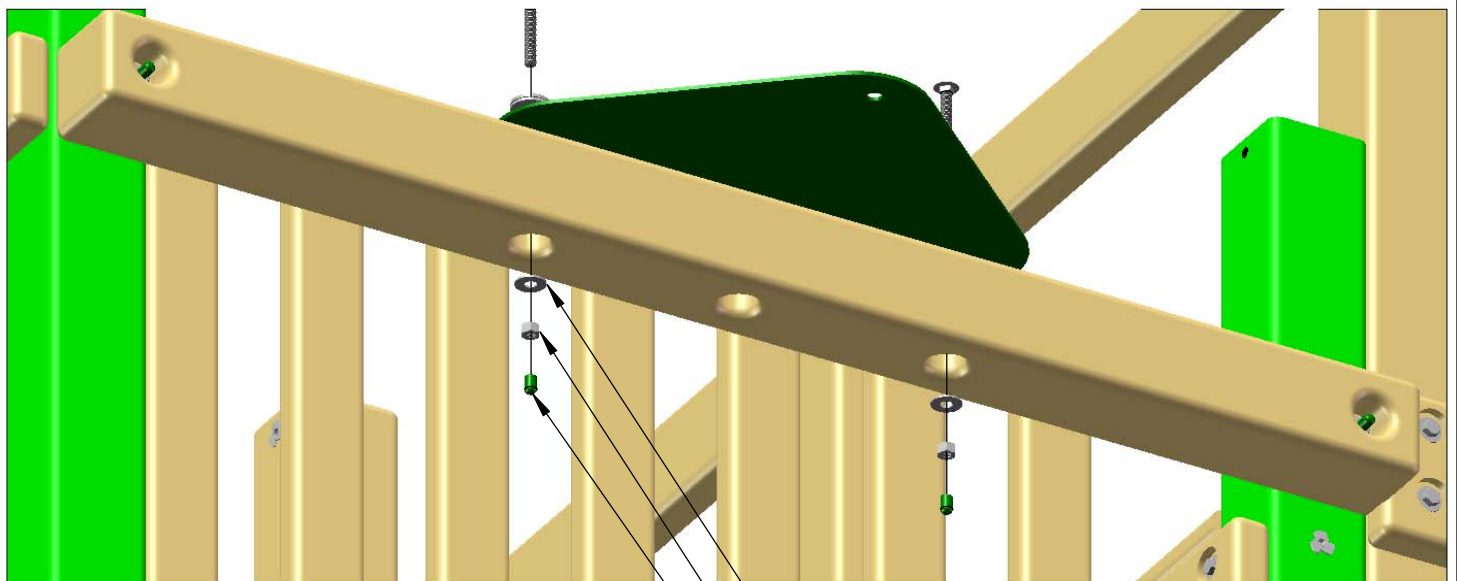

3/8" WASHER

3/8" LOCK NUT

BOLT CAP

STEP 34: IRON DUCTILES

- 1: LINE UP THE HOLES OF THE IRON DUCTILES WITH THE HOLES IN THE SWINGBEAM.
- 2: FASTEN THE SWING HANGER TO THE SWING BEAM USING 6-1/2" OR 7" CARRIAGE BOLTS (SIZE MAY VARY FROM UNIT TO UNIT) WITH TORQUE WASHERS, AND 3/8" WASHERS WITH 3/8" LOCK NUTS.
- 3: PLACE BOLT CAPS OVER EXPOSED THREADS.

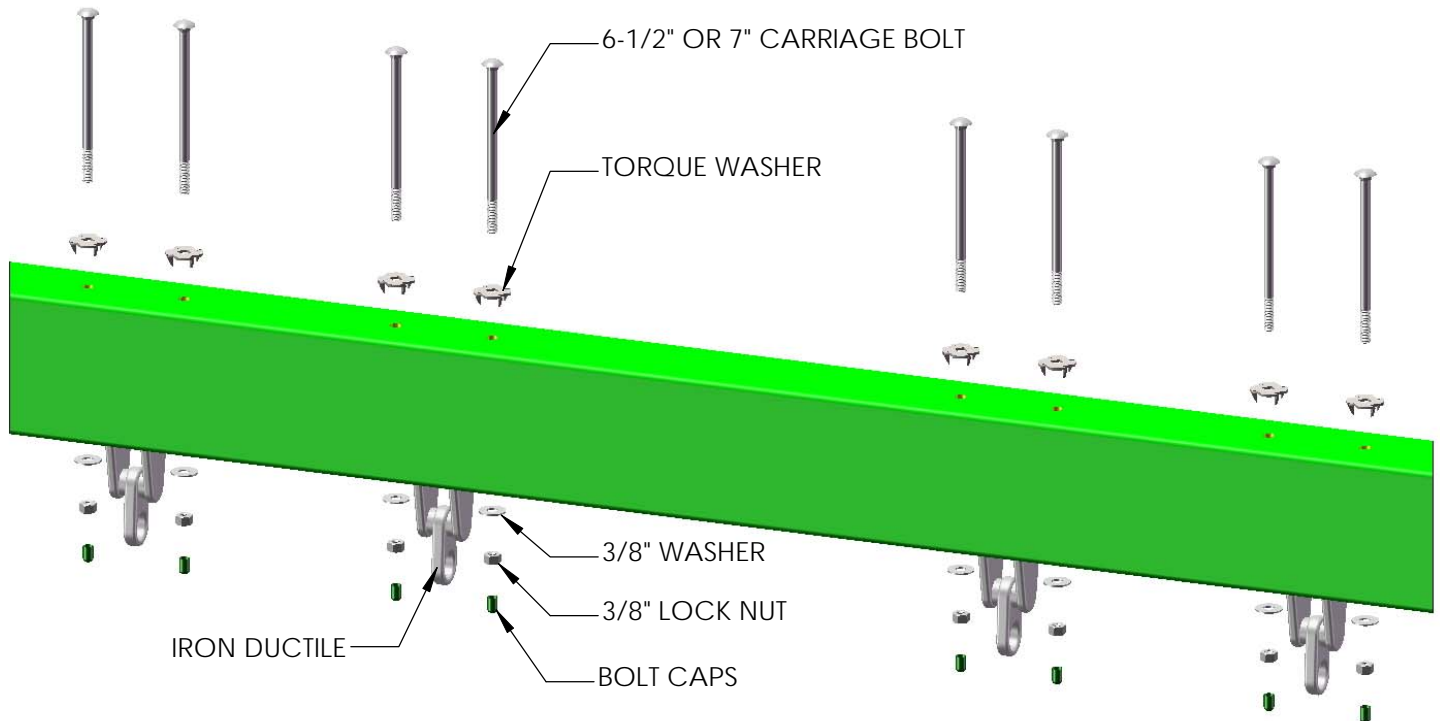

STEP 35: ATTACH SWING LEGS TO BRACKET

1: PLACE THE 4 X 4 X 96" SWING LEGS FLUSH TO THE TOP OF THE SWING LEG BRACKET.

2: FASTEN THE SWING LEGS TO THE SWING LEG BRACKET WITH 3/8 X 3-1/2" LAG SCREWS AND 3/8" WASHERS.

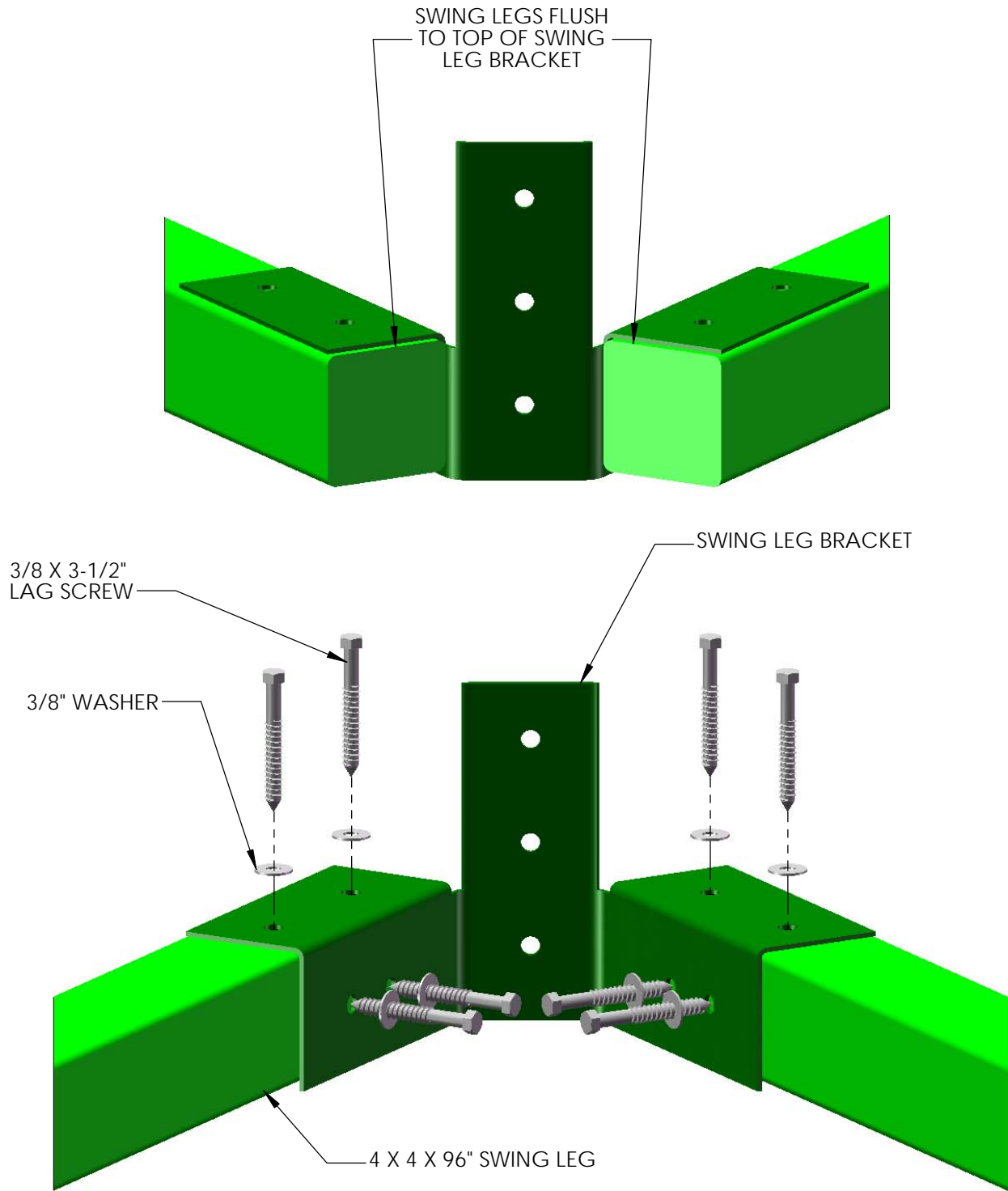

STEP 36: REST SWING BEAM ON FORT

AN EXTRA PERSON IS NEEDED FOR THIS STEP

1: SIT THE SWING BEAM LEGS UPRIGHT.

2: LINE UP THE PRE-DRILLED HOLES, AND REST THE SWING BEAM ON TOP OF THE FORT AND THE SWING BEAM LEGS. MAKE SURE THAT YOU HAVE THE BEAM FACING THE RIGHT WAY.

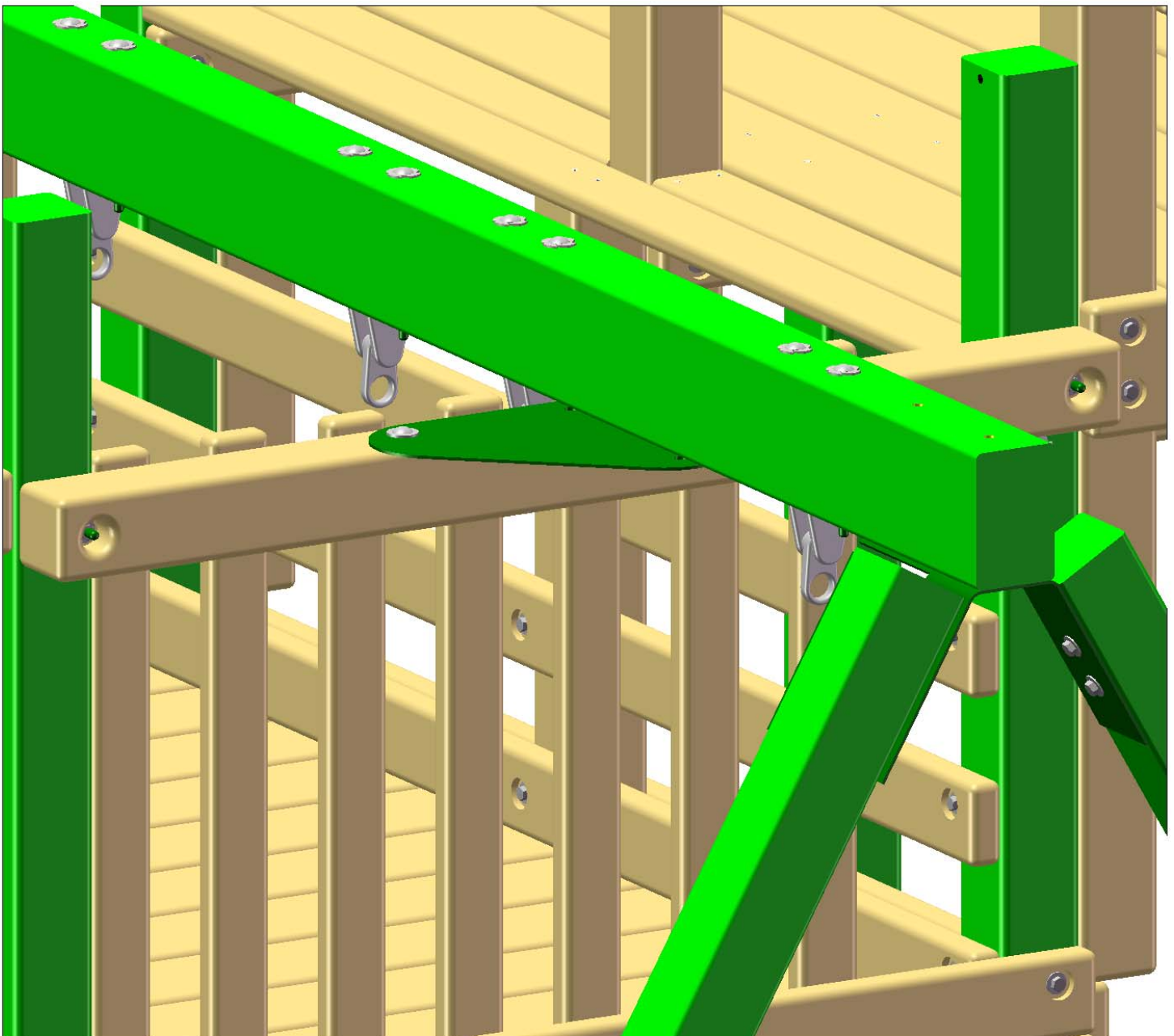

STEP 37: MOUNT SWING BEAM TO SWING BEAM LEGS

- 1: FASTEN THE SWING BEAM TO THE SWING BEAM BRACKET USING 6-1/2" OR 7" CARRIAGE BOLTS WITH TORQUE WASHERS ON TOP OF THE SWING BEAM, AND 3/8" LOCK NUTS WITH 3/8" WASHERS FROM UNDERNEATH.
- 2: USE A 3/8 X 3-1/2" LAG SCREW WITH 3/8" WASHER FOR THE HOLE IN THE CENTER OF THE SWING BEAM BRACKET.
- 3: PLACE A BOLT CAP OVER ANY EXPOSED THREADS.

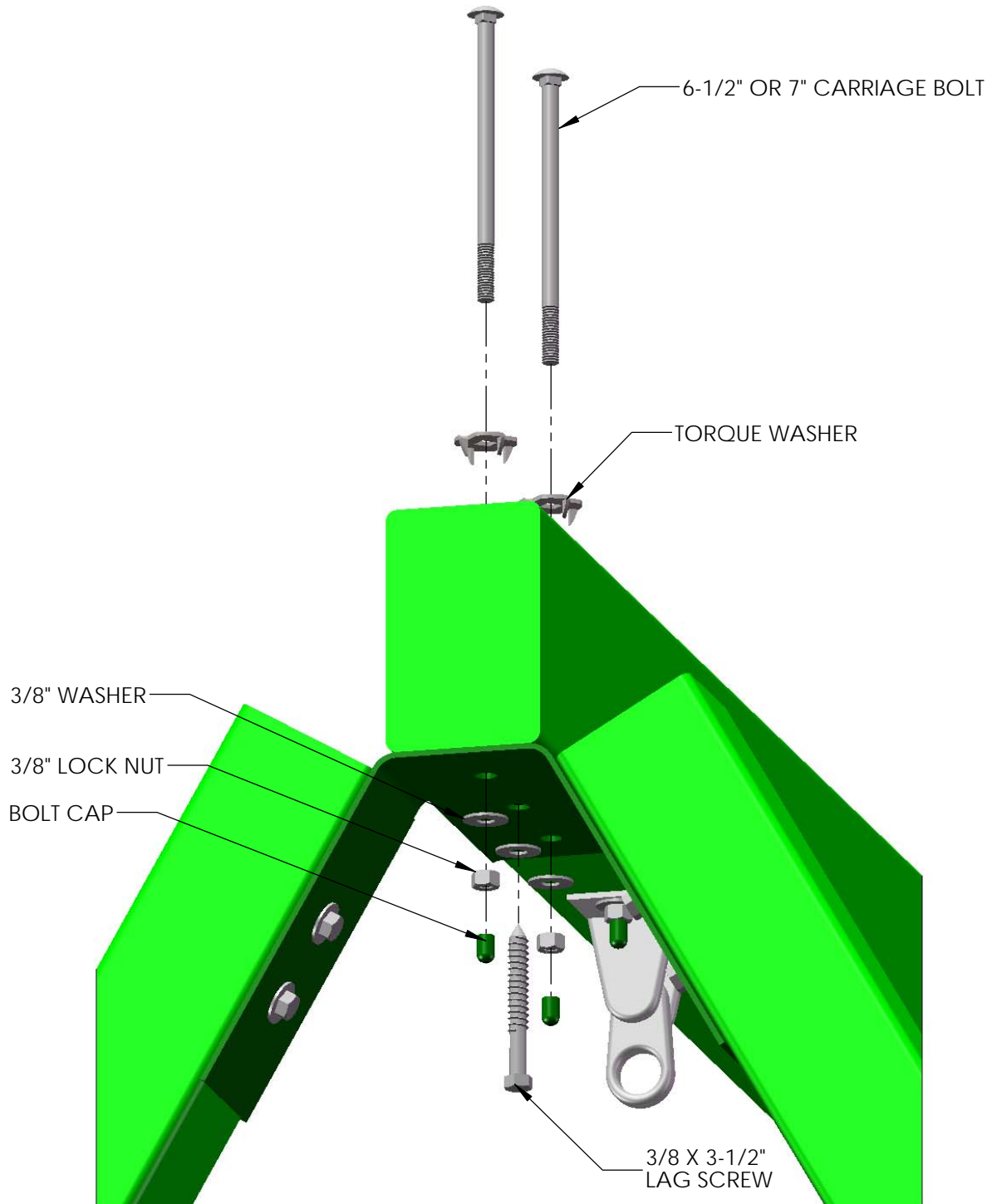

STEP 38: MOUNT SWING BEAM ON FORT

AN EXTRA PERSON IS NEEDED FOR THIS STEP

1: HAVE ONE PERSON WALK THE SWING BEAM OUT TO THE END OF THE FORT FROM INSIDE THE FORT WHILE THE OTHER PERSON CARRIES IT BY THE LEGS.

2: LINE UP THE PILOT HOLES AT THE END OF THE SWING BEAM WITH THE MIDDLE HOLES ON THE SWING BEAM PLATE.

3: FASTEN THE SWING BEAM TO THE SWING BEAM PLATE AND SWING BEAM SUPPORT USING A 9" CARRIAGE BOLT WITH A TORQUE WASHER ON TOP AND A 3/8" LOCK NUT AND WASHER ON THE BOTTOM. PLACE GREEN BOLT CAPS OVER EXPOSED THREADS AFTER SECURING.

4: FASTEN THE SWING BEAM TO THE SWING BEAM PLATE FROM UNDERNEATH WITH A 3/8 X 3-1/2" LAG SCREW AND 3/8" WASHER.

5: USE VISE GRIPS TO HOLD CARRIAGE BOLTS IN PLACE WHEN INSTALLING.

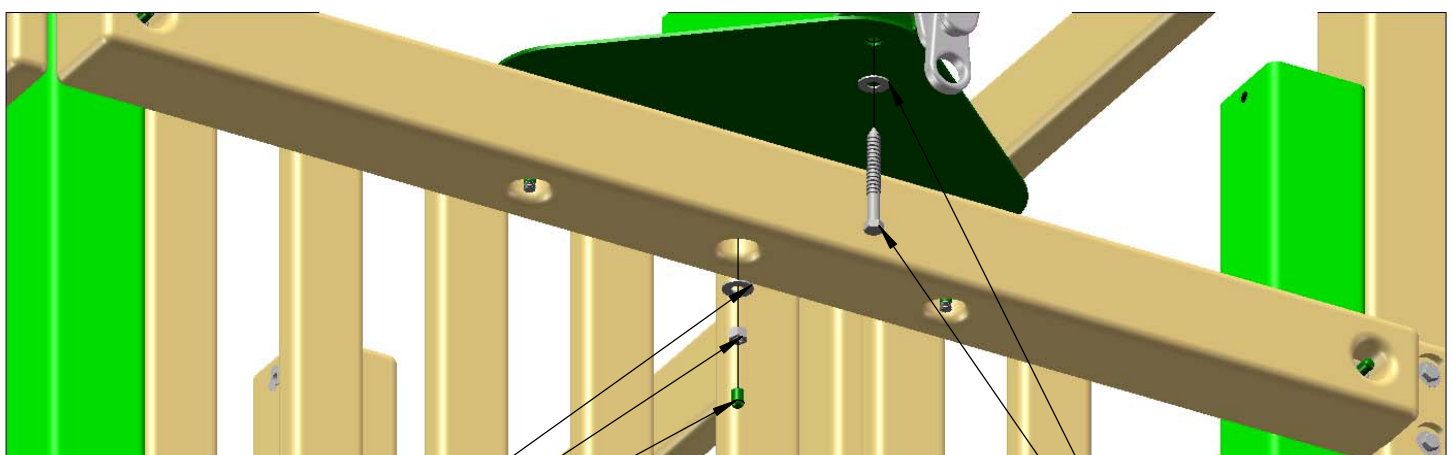
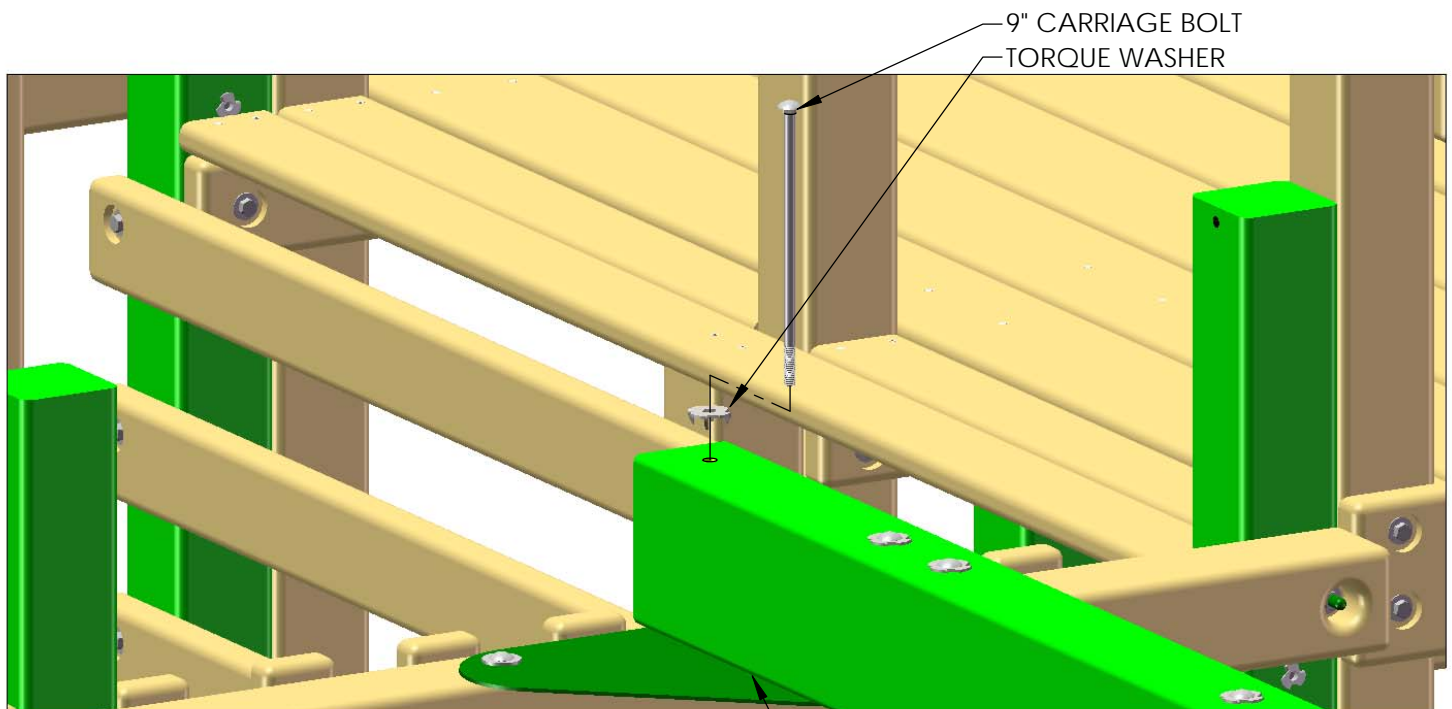

STEP 39: LEVEL SWING BEAM

1: PLACE A LEVEL ON TOP OF THE SWING BEAM AND ADJUST THE BEAM LEGS IN OR OUT AS NEEDED TO MAKE THE SWING BEAM LEVEL.

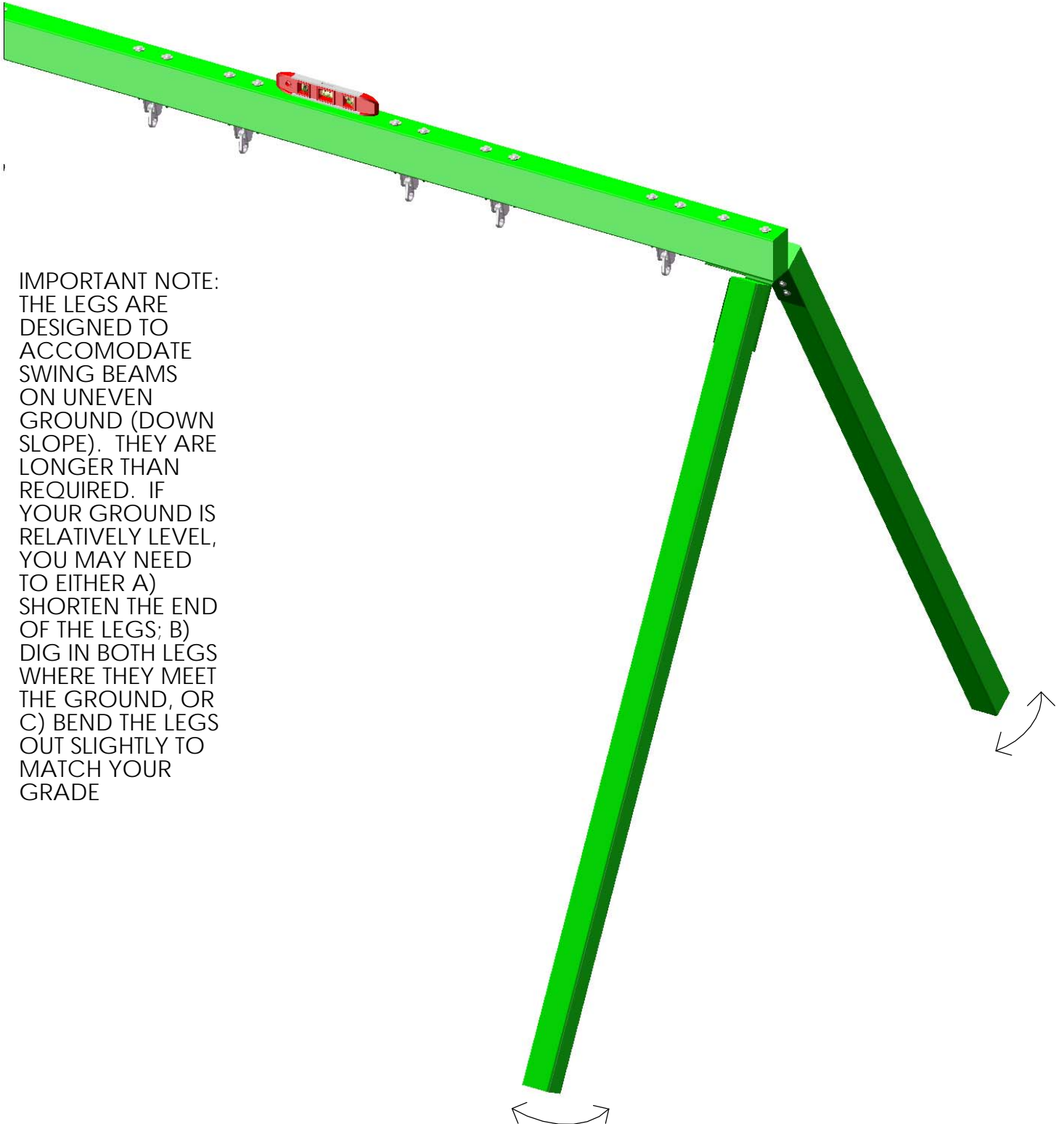

IMPORTANT NOTE:
THE LEGS ARE
DESIGNED TO
ACCOMMODATE
SWING BEAMS
ON UNEVEN
GROUND (DOWN
SLOPE). THEY ARE
LONGER THAN
REQUIRED. IF
YOUR GROUND IS
RELATIVELY LEVEL,
YOU MAY NEED
TO EITHER A)
SHORTEN THE END
OF THE LEGS; B)
DIG IN BOTH LEGS
WHERE THEY MEET
THE GROUND, OR
C) BEND THE LEGS
OUT SLIGHTLY TO
MATCH YOUR
GRADE

STEP 40: SWING LEG CROSS-MEMBER

- 1: POSITION THE 2 X 4 X 58" SWING LEG CROSS-MEMBER AGAINST THE SWING BEAM LEGS.
- 2: LEVEL CROSS-MEMBER AND MARK THE LOCATION OF THE SECURING HOLES INSIDE THE CROSS-MEMBER HOLES.
- 3: USE 3/8 X 3-1/2" LAG SCREWS WITH 3/8" WASHERS TO SECURE THE CROSS-MEMBER TO THE SWING BEAM LEGS.

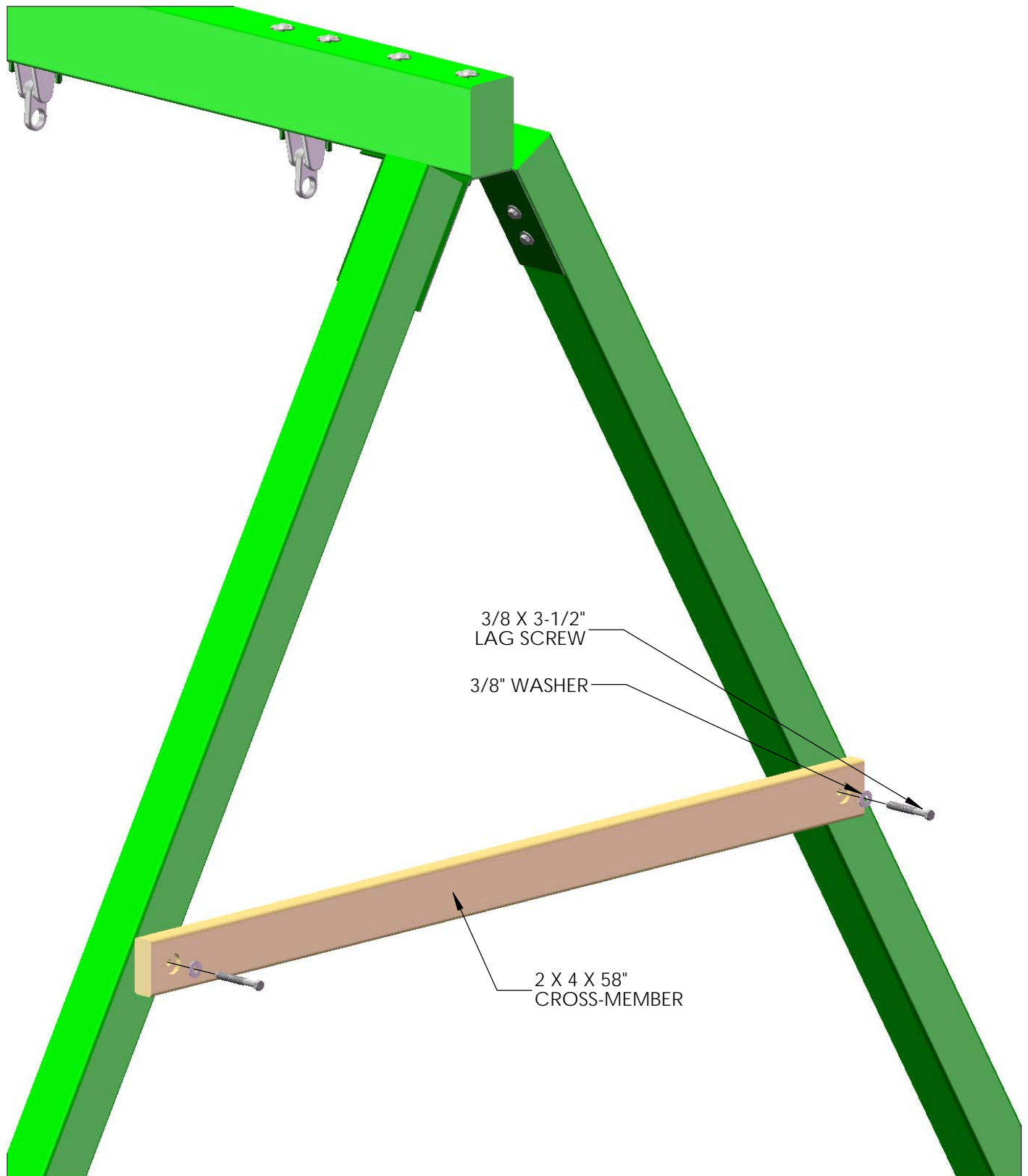

STEP 41: GLIDER SWING ASSEMBLY

- 1: LINE UP THE HOLES OF THE SEAT WITH BOTH END HANDLE ASSEMBLIES.
- 2: MAKE SURE THAT THE FLAT SIDE OF THE SEAT IS FACING UP.
- 3: INSERT THE PROVIDED BOLTS THROUGH THE HOLES WITH A WASHER AND SECURE IT WITH A WASHER AND NUT.

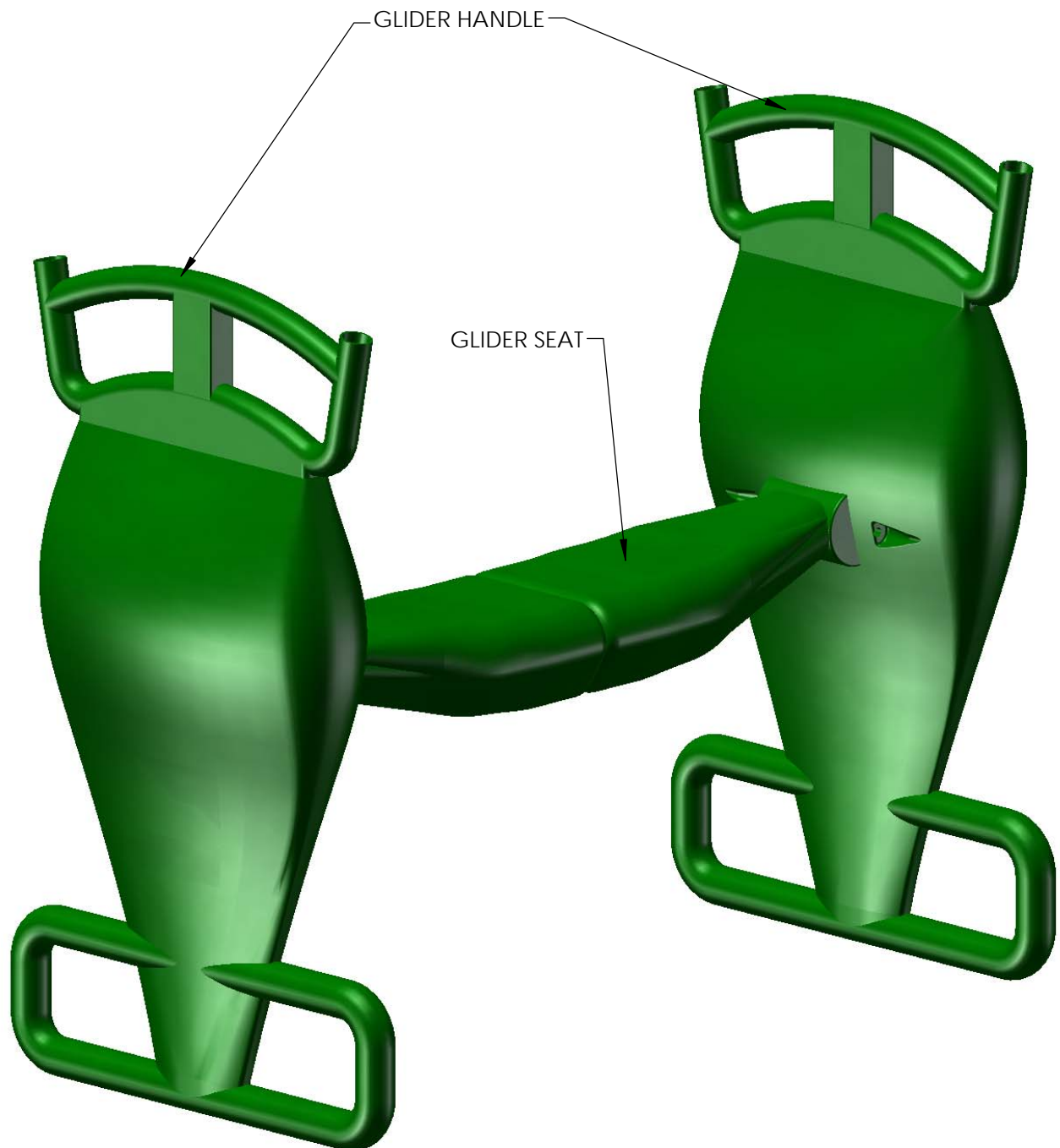

STEP 42: HANGING THE SWINGS

- 1: START BY ATTACHING ONE SPRING CLIP TO EACH IRON DUCTILE ON THE SWING BEAM.
- 2: ATTACH ONE CHAIN PER ACCESSORY TO EACH SPRING CLIP.
- 3: ADJUST HEIGHT AS NEEDED

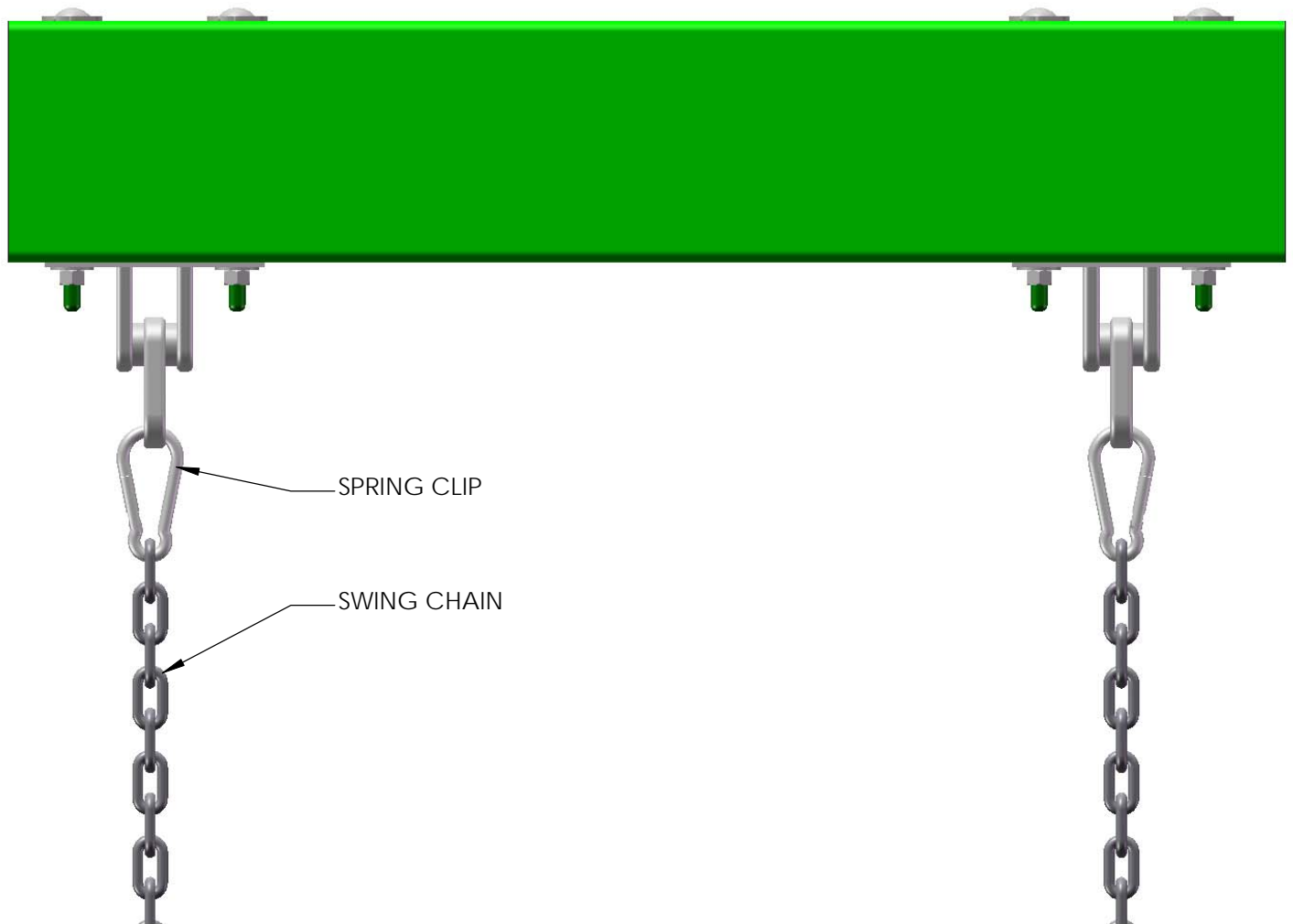

STEP 43: ROOF SUPPORTS

1: DRILL PILOT HOLES IN THE TRIANGLE TO A PATTERN THAT MATCHES THE 2 X 4 X 51" SUPPORTS.

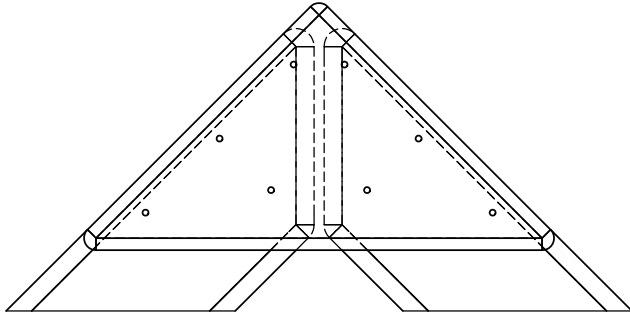

THIS PICTURE SHOWS A PATTERN WITH THE 2 X 4 X 51" UNDER THE ROOF TRIANGLE. THE 2 X 4 PARTS HAVE LIGHTENED EDGES TO SHOW THE ASSEMBLY

2: ATTACH A ROOF SUPPORT TO EACH OF THE LOWER LEVEL CORNER POSTS WITH 5/16 X 4-1/2" HEX BOLTS AND WASHERS INTO THE T-NUTS INSTALLED IN STEP #1.

3: ATTACH THE ROOF SUPPORTS TO THE UPPER LEVEL CORNER POST AND LAG POSTS WITH 5/16 X 4-1/2" HEX BOLTS WITH WASHER AND INSTALL A T-NUT ON THE BACK SIDE OF THE TOP HOLES OF THE LAG POSTS.

4: MEET THE ANGLES OF THE ROOF SUPPORTS AND ATTACH THE TRIANGLES WITH 2" WOOD SCREWS.

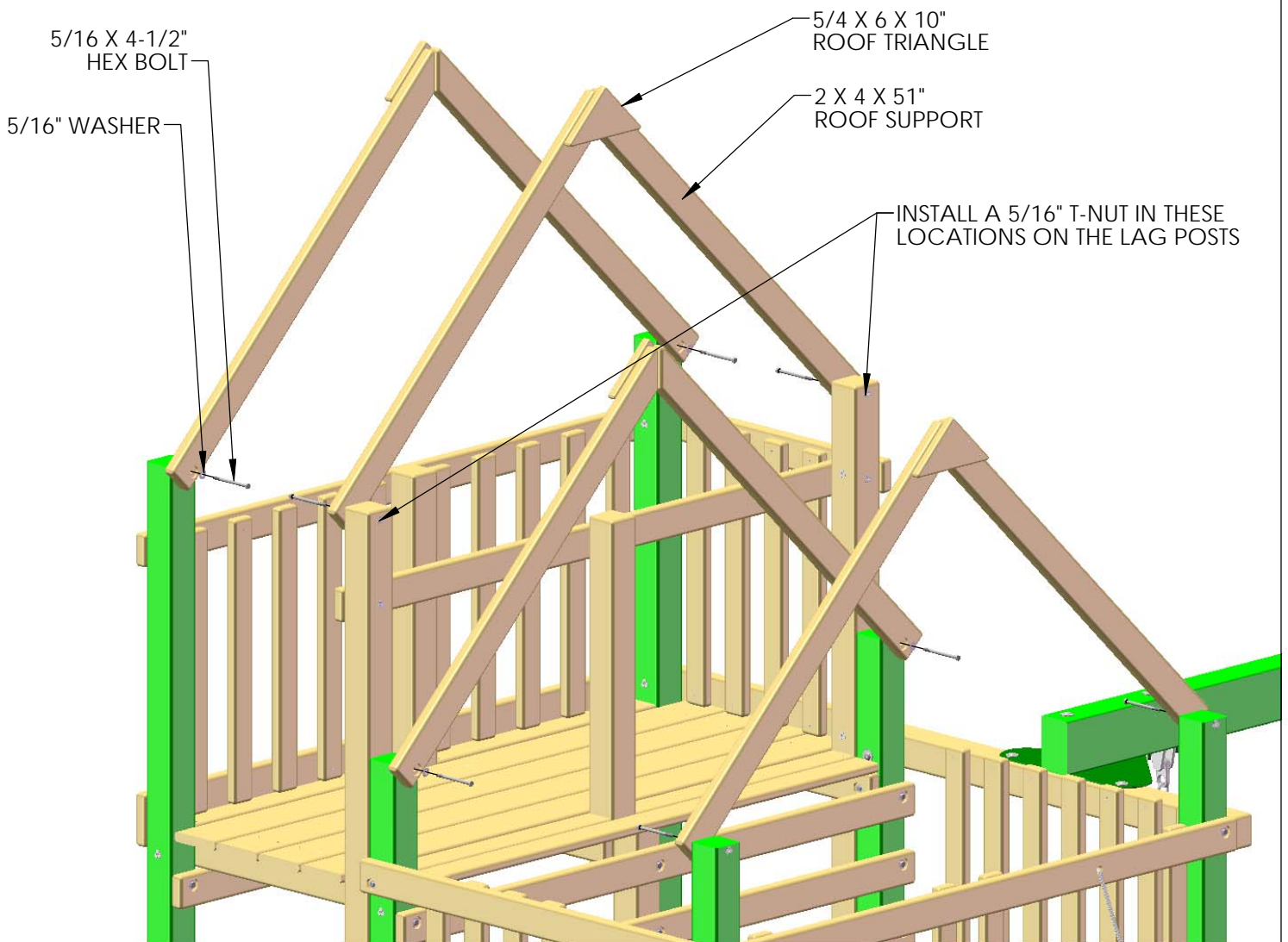

STEP 44: ROOF BOARDS

1: FIND THE TONGUE-IN-GROOVE PARTS BELOW AND DRILL 1/8" PILOT HOLES TO THE DIMENSIONS SHOWN.

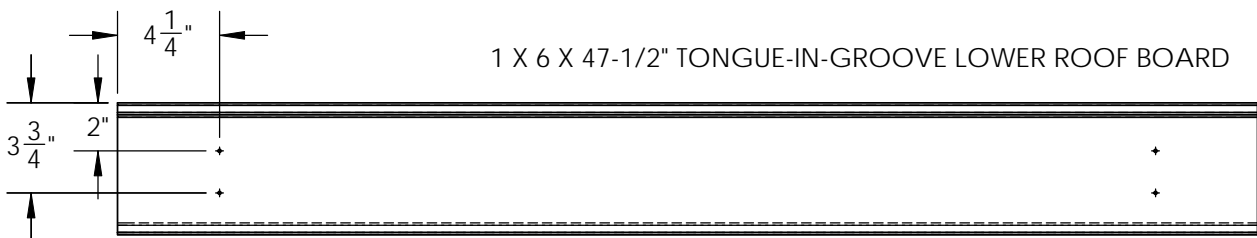
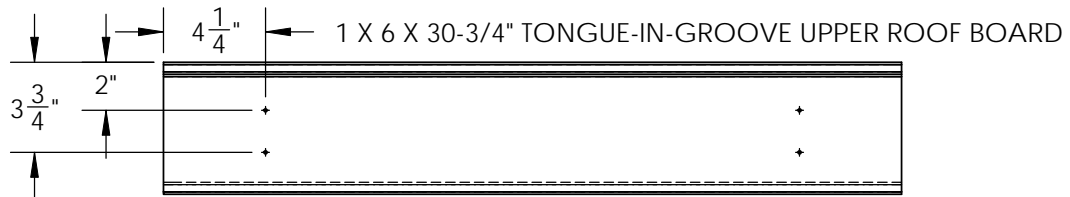
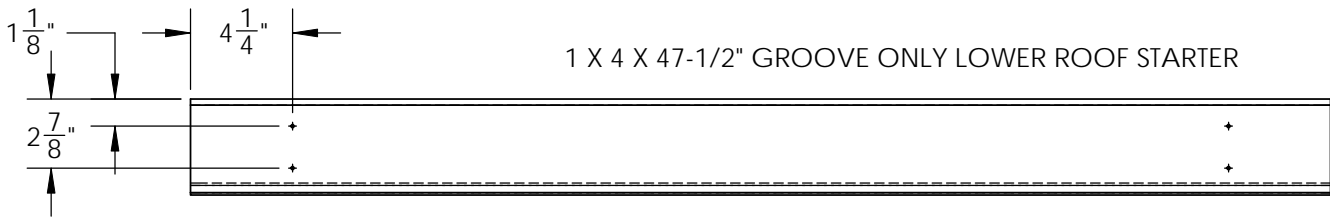
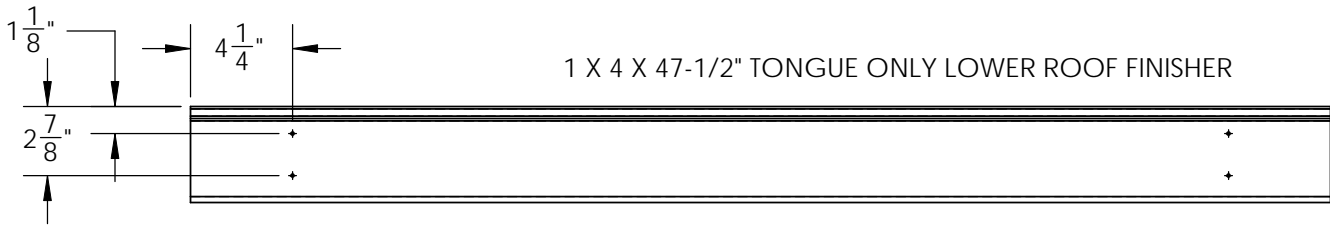
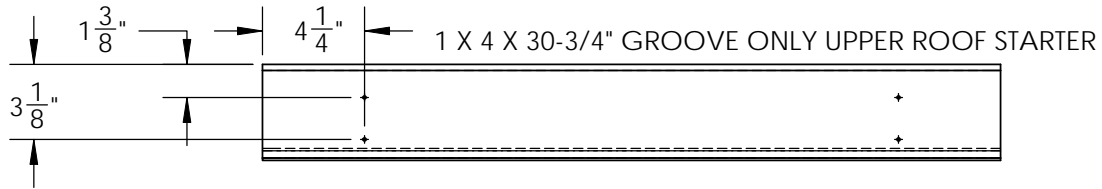
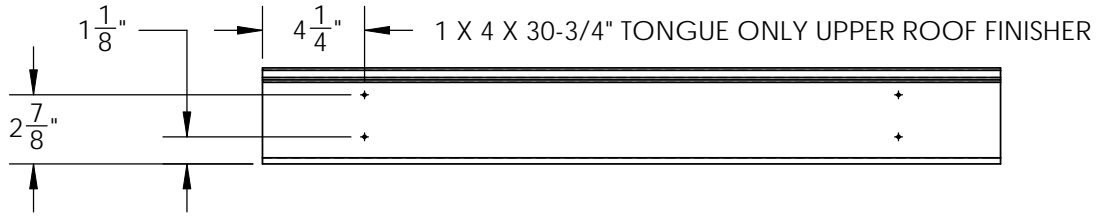

STEP 45: ROOF

1: INSTALL A ROOF STARTER AT THE TOP OF EACH ROOF SUPPORT. THE GROOVE OF THE STARTERS SHOULD FACE DOWNWARD AND THE TOPS OF THE TWO SHOULD MEET AT THE PEAK OF THE SUPPORTS. SECURE THE STARTERS TO THE SUPPORTS WITH 1-1/2" WOOD SCREWS THROUGH THE PILOT HOLES.

2: INSTALL A ROOF BOARD BELOW THE STARTERS WITH THE TOUNGE INSERTED INTO THE GROOVE. NOTE: ALL ROOF BOARDS SHOULD HAVE A 3-1/2" OVERHANG PAST THE ROOF SUPPORTS.

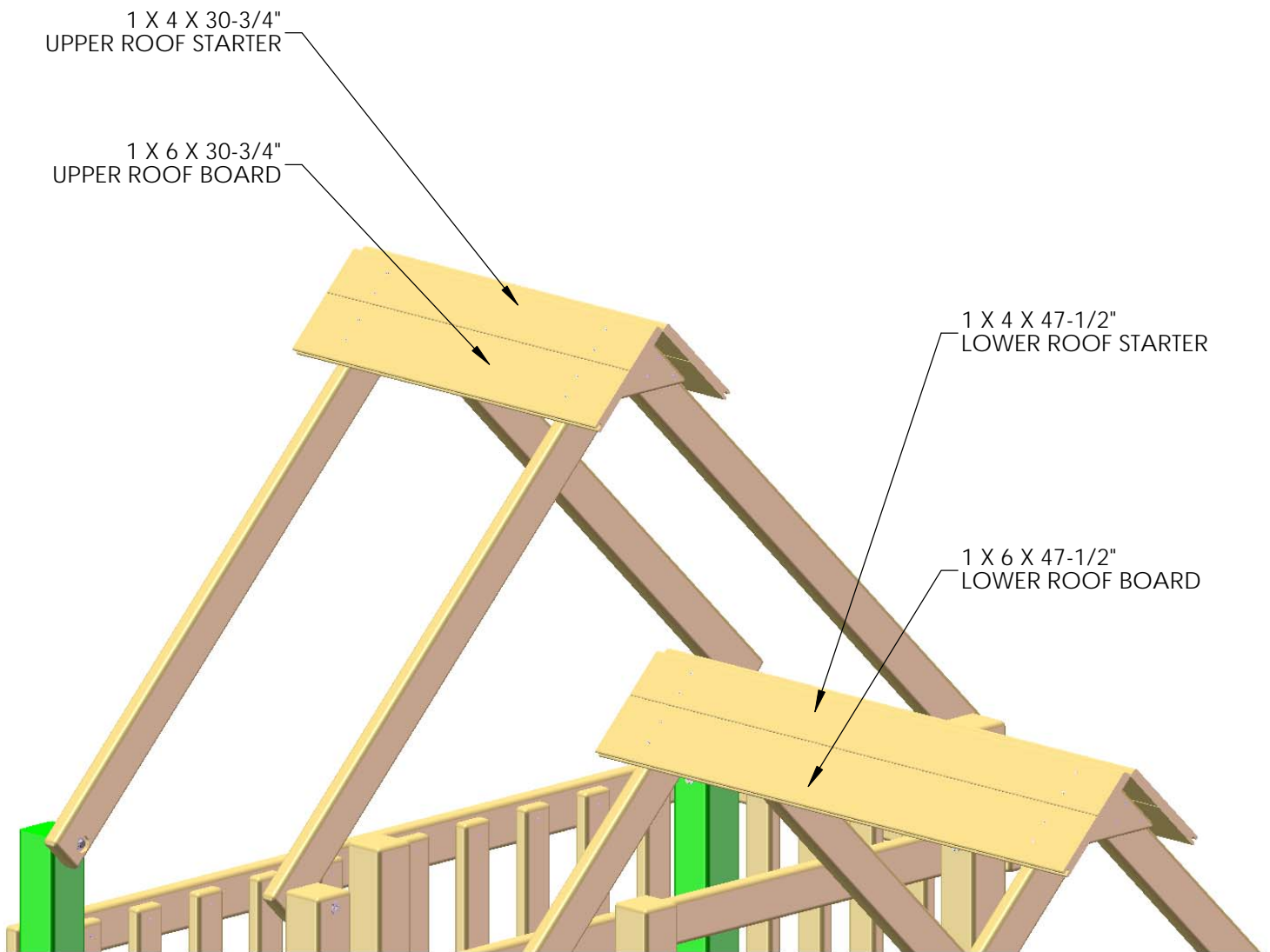

STEP 46: ROOF

1: FIND THE 47-1/2" ROOF PEAK AND THE 30-3/4" ROOF PEAK. DRILL PILOT HOLES IN THE PEAKS TO THE SAME DIMENSIONS AS THE ROOF STARTER BOARDS.

2: ATTACH THE ROOF PEAKS ON TOP OF THE TWO ROOF STARTERS AND SECURE THEM WITH 1-1/2" WOOD SCREWS THROUGH THE PILOT HOLES.

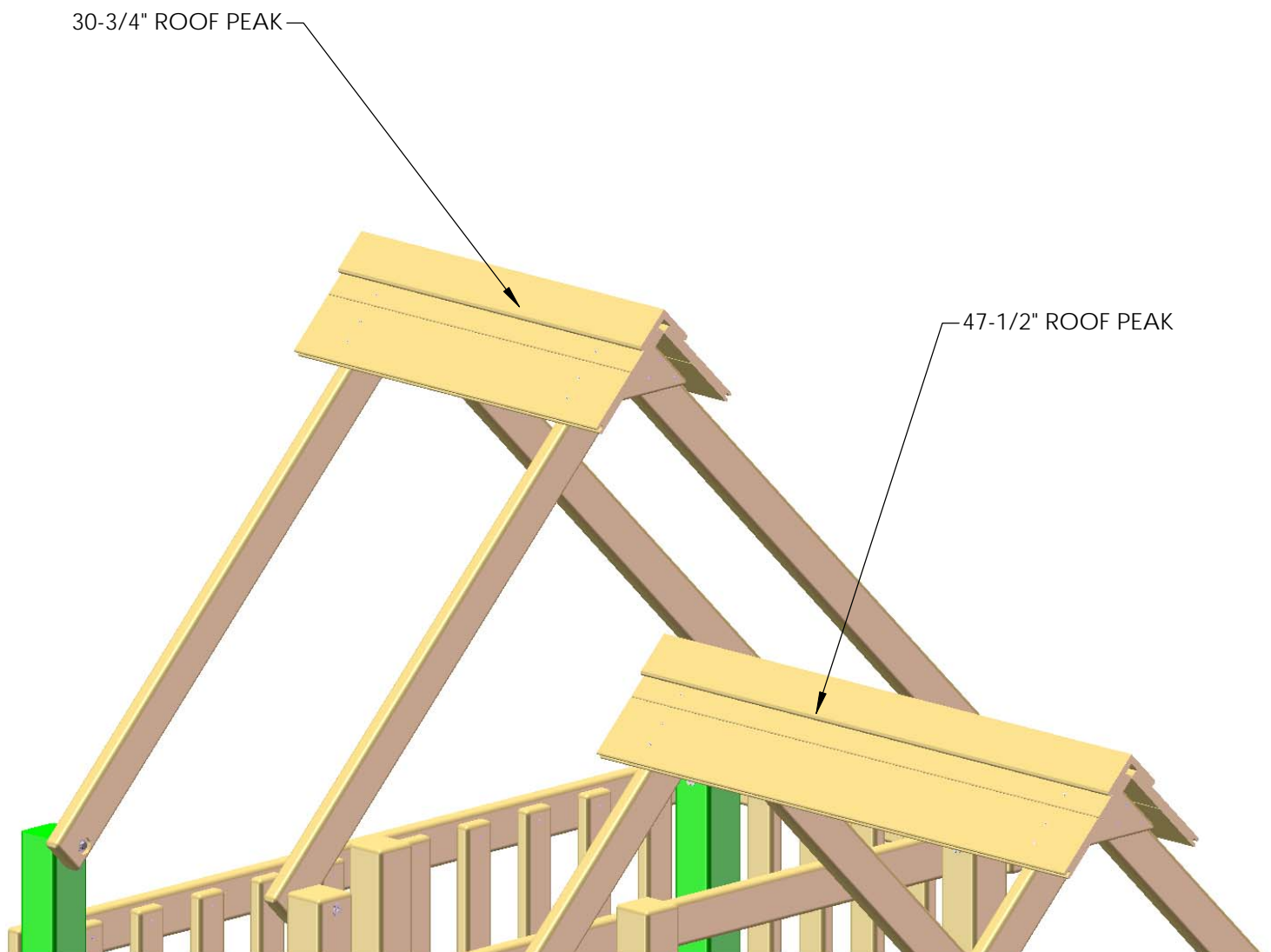

STEP 47: ROOF

1: CONTINUE TO INSTALL THE ROOF BOARDS BY INSERTING THE TONGUE INTO THE GROOVE OF THE PREVIOUS BOARD UNTIL THERE ARE NINE ROOF BOARDS PER SIDE (NOT COUNTING ROOF STARTERS). ATTACH WITH 1-1/2" WOOD SCREWS

2: INSTALL THE ROOF FINISHERS BELOW THE LAST ROOF BOARDS. THE FINISHERS WILL OVERHANG THE BOTTOM OF THE ROOF SUPPORTS BY ABOUT 2".

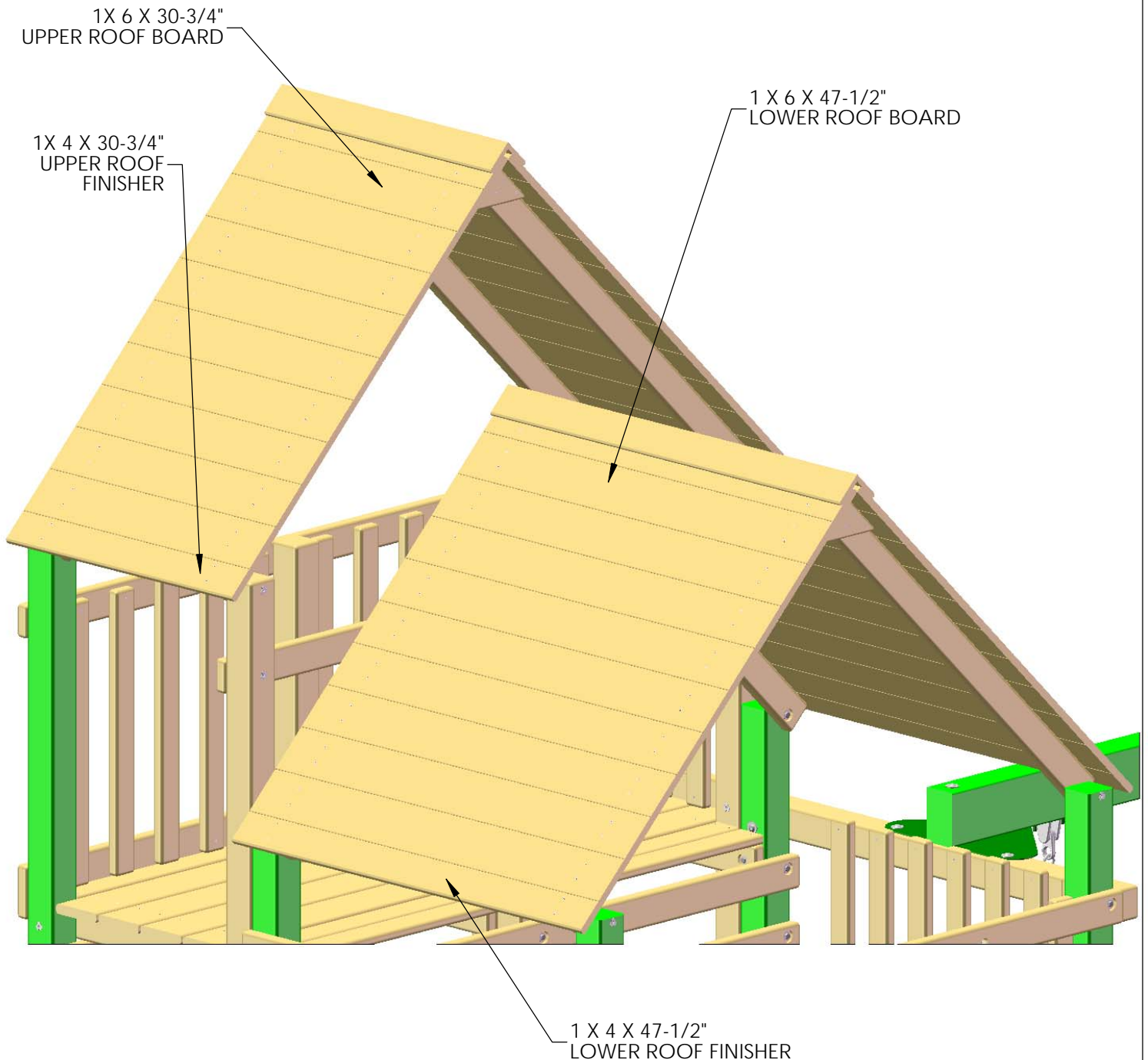

STEP 48: SUNBURST

1: PRE-DRILL HOLES IN THE 2 X 6 X 16" SUN TO THE PATTERN SHOWN BELOW.

2 X 6 X 16"
SUN

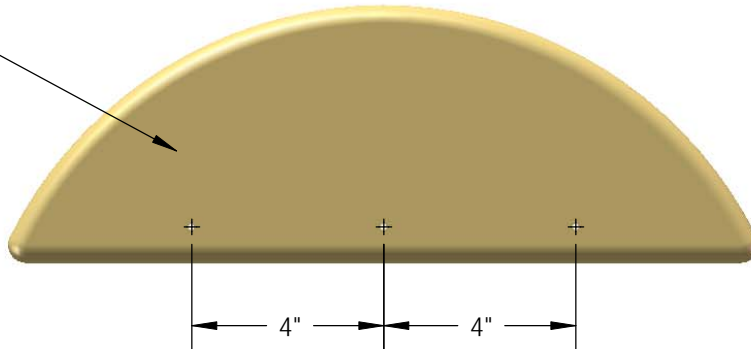

2: PLACE THE 2 X 6 X 16" SUN CENTERED AGAINST THE 5/4 X 3 X 42" SUN SUPPORT. FASTEN THE SUN TO THE SUN SUPPORT WITH 2" WOOD SCREWS.

5/4 X 3 X 42"
SUN SUPPORT

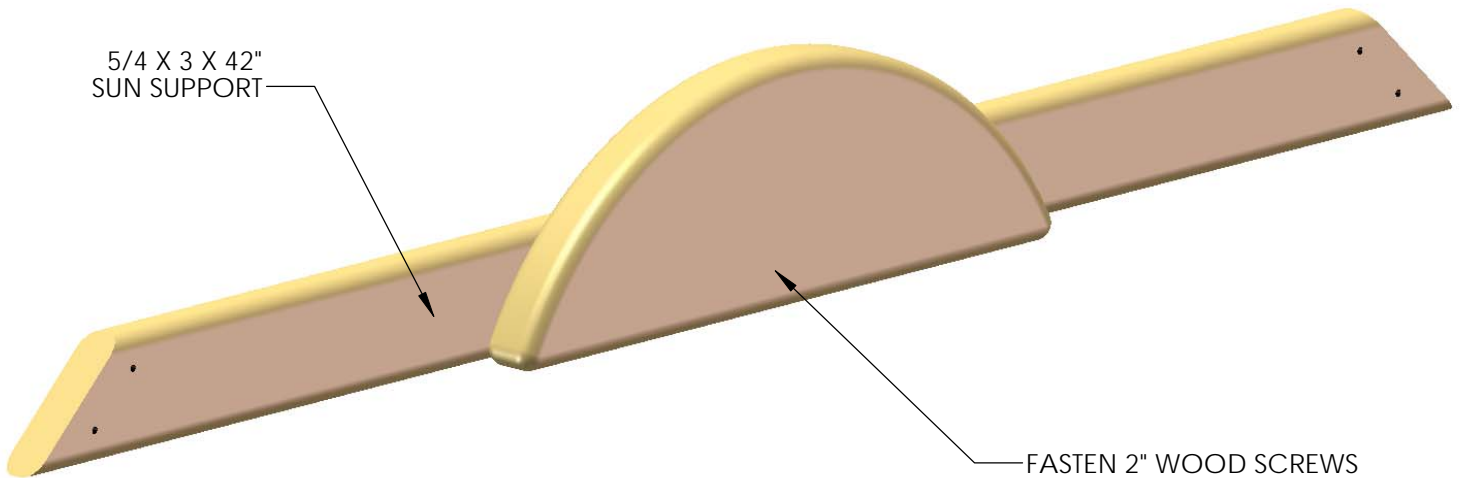

FASTEN 2" WOOD SCREWS
FROM THIS SIDE

STEP 49: SUNBURST

- 1: PLACE THE ASSEMBLY MADE IN THE PREVIOUS STEP UNDERNEATH THE ROOF BOARDS, AND AGAINST THE ANGLED ROOF SUPPORTS.
- 2: FASTEN THE SUN ASSEMBLY TO THE FORT WITH 2" WOOD SCREWS FROM THE OUTSIDE INTO THE ROOF SUPPORTS.
- 3: TWO OF THE SUN ASSEMBLIES WILL BE INSTALLED ON THE UPPER LEVEL OF THE FORT, WHILE ONLY ONE WILL BE INSTALLED ON THE LOWER LEVEL (SEE ILLUSTRATION BELOW).

NOTE: SOME ROOF BOARDS HAVE BEEN REMOVED FROM VIEW FOR LOCATION CLARITY OF THE SUN ASSEMBLIES.



FASTEN WITH 2" WOOD SCREWS FROM THIS SIDE OF THE ROOF SUPPORT BOARDS.

STEP 50: SUNBURST

- 1: CENTER THE 5/4 X 2 X 16" LARGE RAY ONTO THE HALF SUN AND THE ROOF SUPPORT BOARDS AND FASTEN WITH TWO 1-1/2" SCREWS.
- 2: EQUALLY SPACE THE SMALL RAYS ABOUT THE HALF SUN (THREE ON EACH SIDE OF LARGE RAY) AND MARK THE POSITION OF THE SMALL SUNRAYS WITH A PENCIL.
- 3: SECURE THE SMALL SUNRAYS ONE AT A TIME TO THE HALF SUN AND THE ROOF SUPPORT BEAMS AND LINE THEM UP WITH THE MARK DRAWN. FASTEN THE SMALL SUNRAYS WITH TWO 1-1/2" WOOD SCREWS EACH. REPEAT ON OTHER SIDE OF FORT.

NOTE: SOME ROOF BOARDS HAVE BEEN REMOVED FROM VIEW FOR LOCATION CLARITY OF THE SUNRAYS.

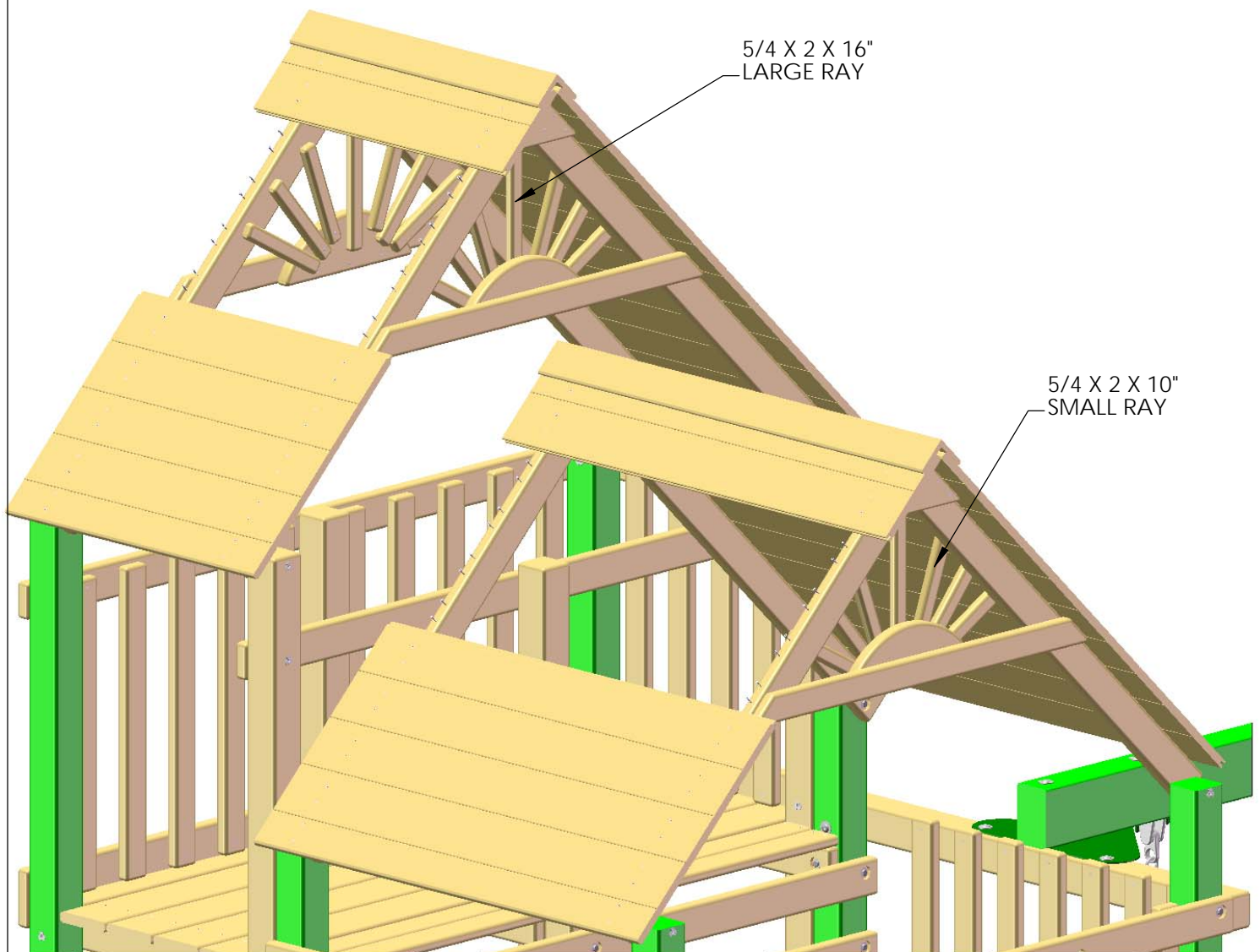

STEP 51: PICNIC TABLE

1: PLACE THE 2 X 4 X 15" PICNIC TABLE SUPPORT ON TOP OF THE 2 X 4 X 30" PICNIC TABLE VERTICAL SUPPORT AND POSITION THE BOARDS AT A RIGHT ANGLE.

2: ENSURE THAT THE PICNIC TABLE SUPPORT AND THE PICNIC TABLE VERTICAL SUPPORT ARE SQUARE AND FASTEN THE PICNIC TABLE SUPPORT TO THE VERTICAL SUPPORT WITH THREE 2 1/2" WOOD SCREWS IN THE PATTERN SHOWN BELOW. MAKE SURE TO ASSEMBLE THE PICNIC TABLE SUPPORT AND THE PICNIC TABLE VERTICAL SUPPORT TO ACCOMMODATE OPPOSITE SIDES OF THE PICNIC TABLE. MAKE SURE THE ASSEMBLY IS SQUARE BEFORE PROCEEDING TO THE NEXT STEP.

3: FASTEN THE ASSEMBLY CREATED FROM THE PREVIOUS TWO STEPS TO THE CORNER POST. POSITION THE ASSEMBLY SO THAT THE PICNIC TABLE SUPPORT IS ON THE OUTSIDE OF THE CORNER POST, AND THE VERTICAL SUPPORT IS ON THE INSIDE OF THE 2 X 6. FASTEN THE ASSEMBLY TO THE UNIT WITH THREE 2" WOOD SCREWS IN THE PICNIC TABLE SUPPORT, AND TWO 2-1/2" WOOD SCREWS IN THE 2 X 6 AT THE BOTTOM. (SEE PATTERN BELOW)

COMPLETE THIS STEP FIRST. (SEE SUB-STEP 1 AND 2)

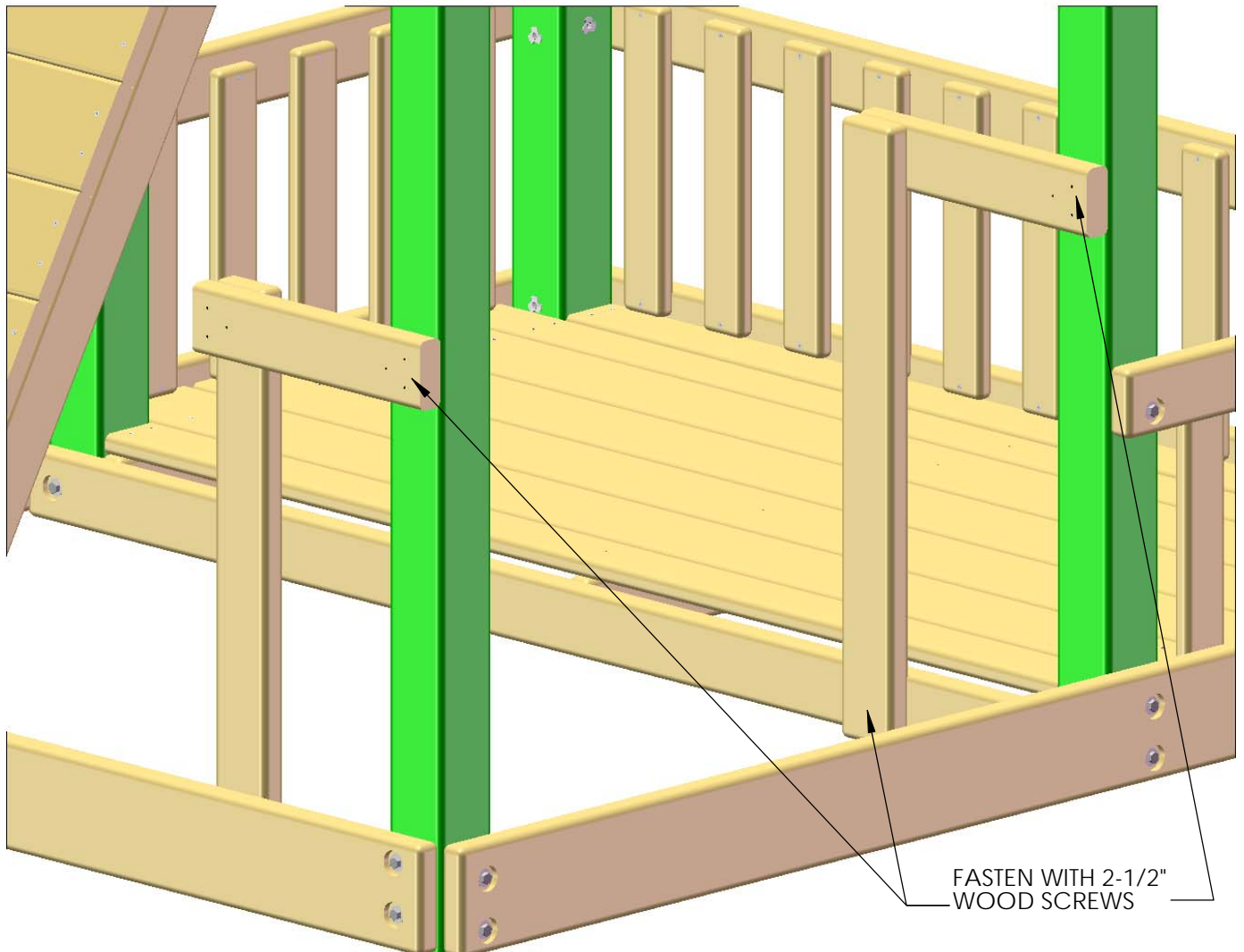
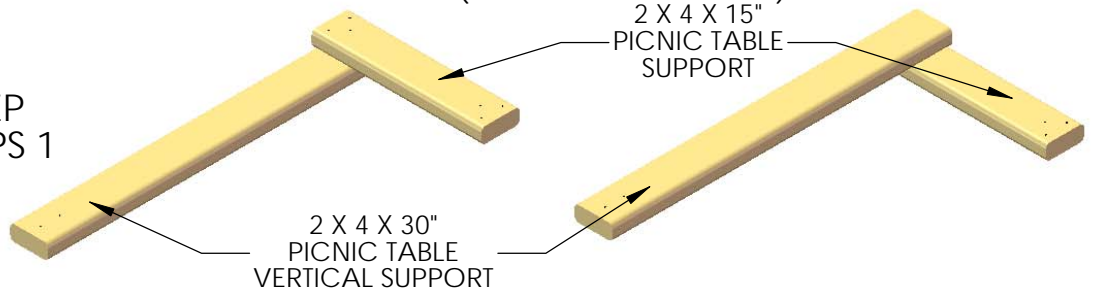

STEP 52: PICNIC TABLE

1: MEASURE 18" FROM THE GROUND UP AND MARK THIS POINT ON THE CORNERPOST.

2: ATTACH THE SEAT SUPPORT TO THE OUTSIDE OF THE CORNER POST SO THAT THE TOP IS AT 18" FROM THE GROUND. ATTACH IT WITH THREE 2-1/2" WOOD SCREWS IN EACH END, THEN LEVEL SEAT SUPPORT AND ATTACH IT TO THE VERTICAL SUPPORT ON EACH SIDE.

3: REPEAT THESE STEPS FOR THE OPPOSITE SIDE OF THE PLAYSET.

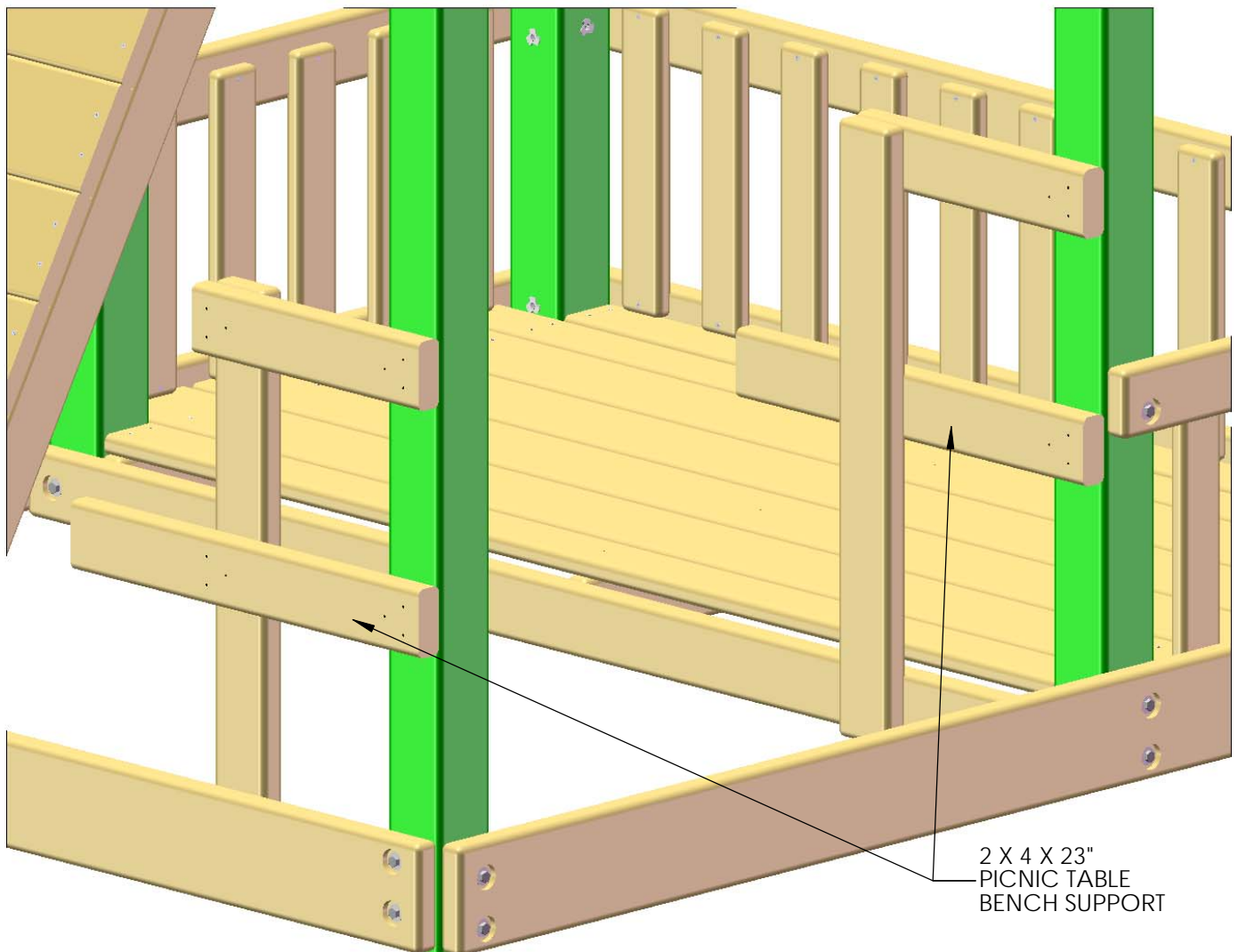

STEP 53: PICNIC TABLE

- 1: ATTACH THE PICNIC TABLE SEAT ON THE SEAT SUPPORTS WITH TWO 2" WOOD SCREWS IN EACH END.
- 2: ATTACH THE PICNIC TABLE TOPS TO THE TABLE SUPPORTS WITH TWO 2" WOOD SCREWS IN EACH END.

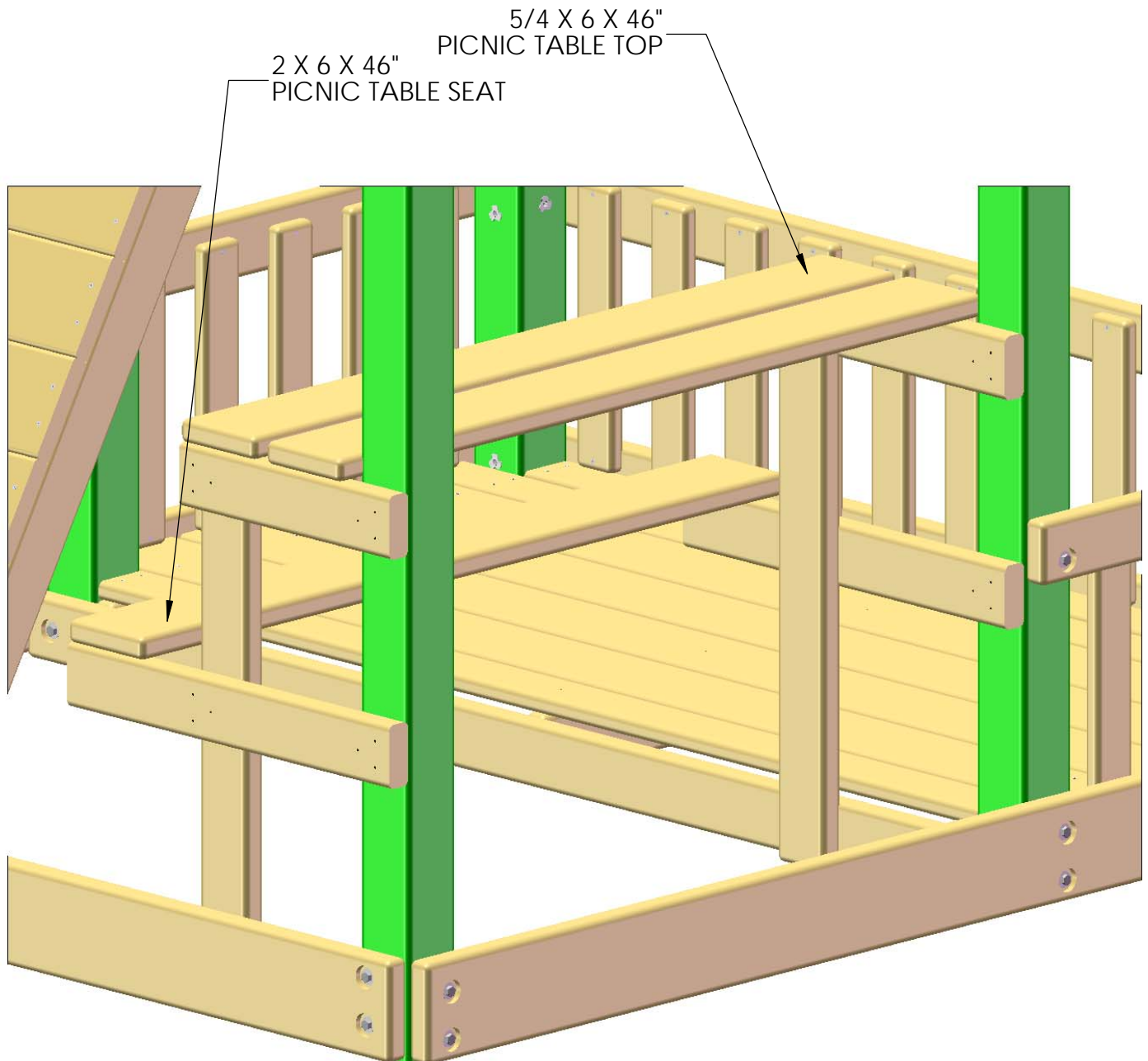

STEP 54: INSTALLING THE WAVE SLIDE

1: POSITION THE WAVE SLIDE TO THE OPEN SECTION OF THE FRONT FACE BOARD. SECURE THE SLIDE TO DECK WITH 1-1/4" WOOD SCREWS THROUGH THE DIMPLES IN THE SLIDE AND INTO THE TOP OF THE DECK BOARDS.

NOTE: DO NOT OVER TIGHTEN THE SCREWS OR YOU WILL BREAK THE SLIDE SCREW HOLES.

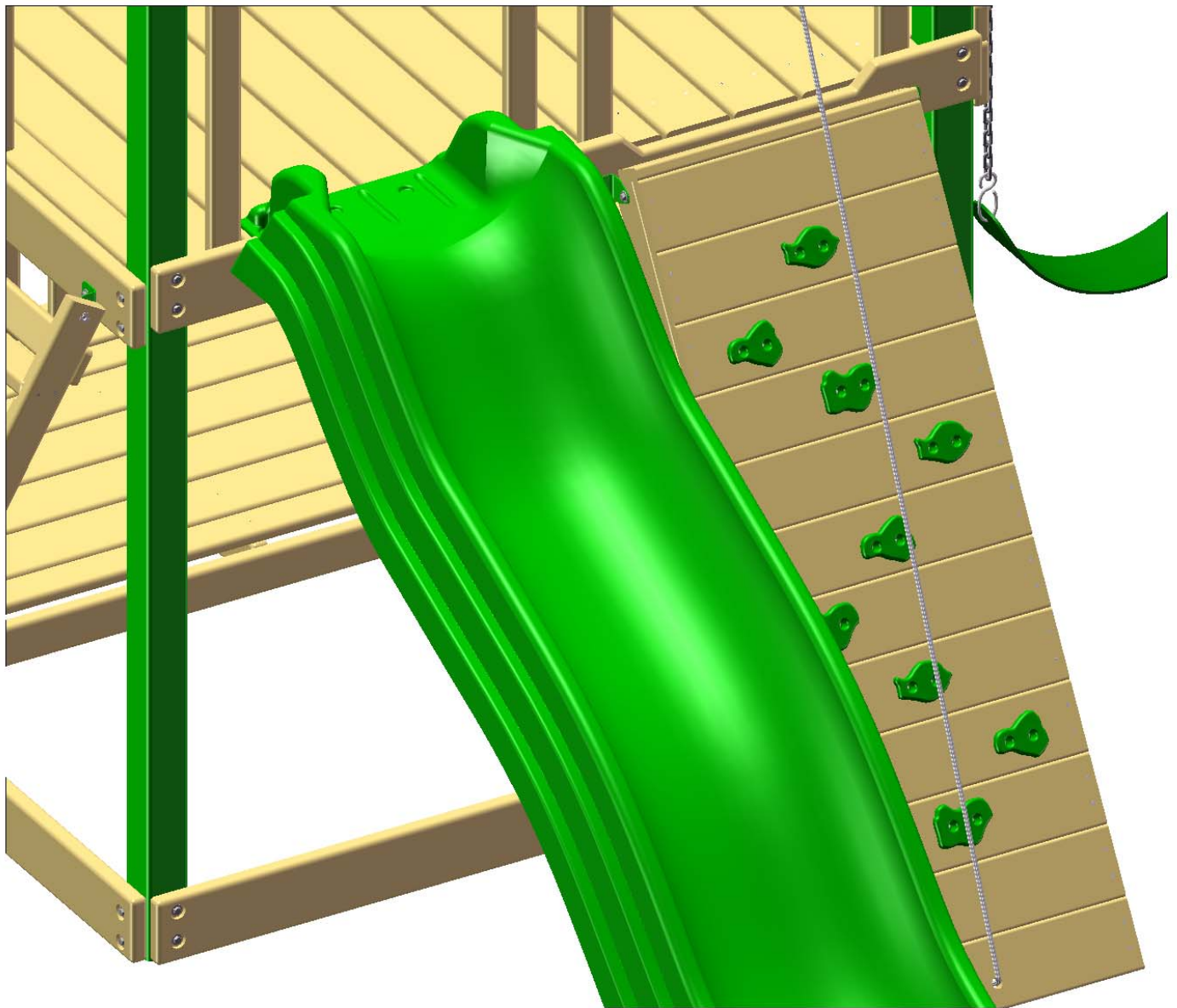

STEP 55: SAFETY HANDLES

- 1: ATTACH THE HANDLES WITH THE PAN HEAD SCREWS THAT ARE PROVIDED TO THE CENTER LAG POST.
- 2: POSITION THE HANDLES 8-1/2" FROM THE UPPER DECK.

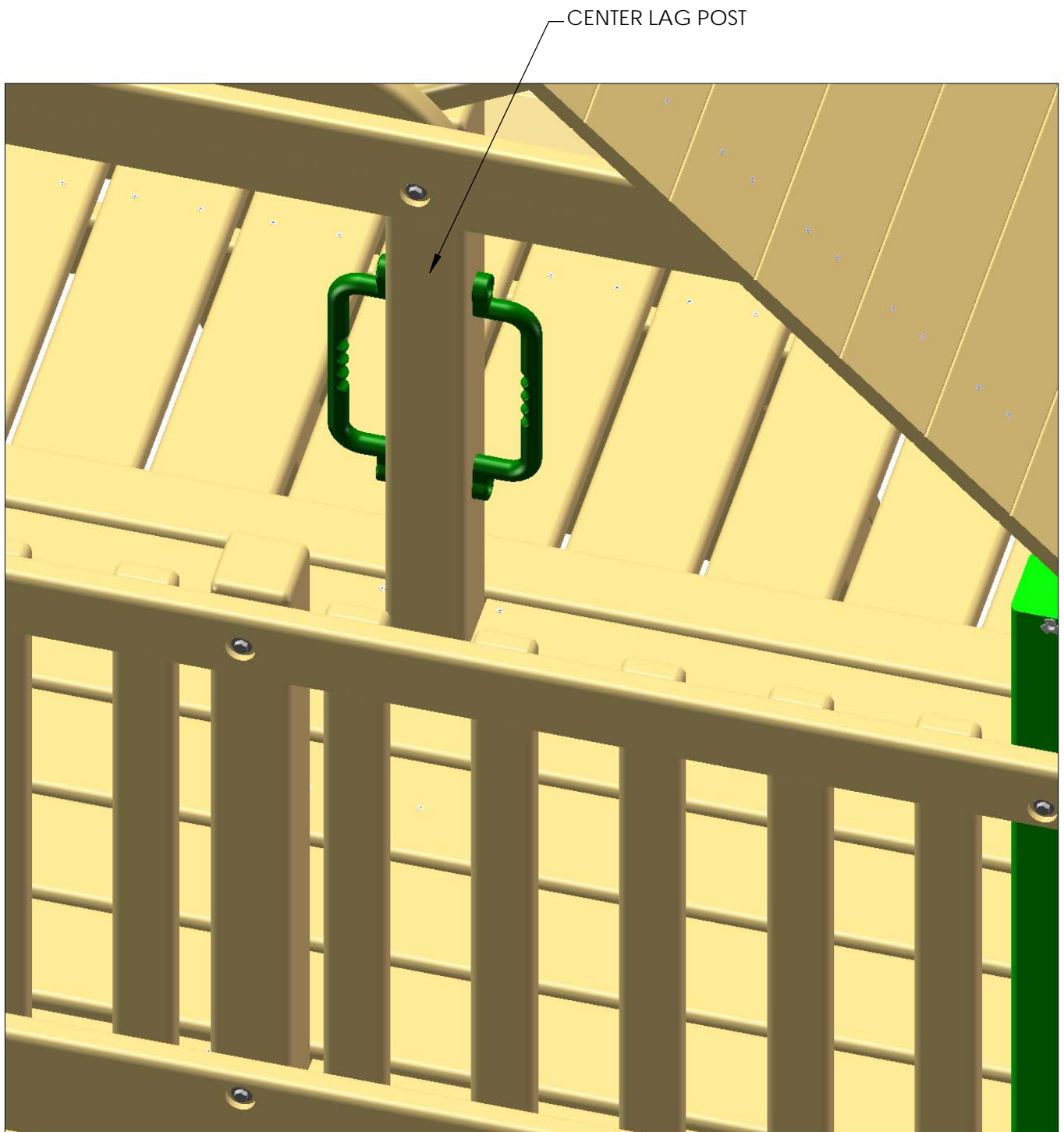

SAFETY HANDLES AS SHOWN FROM THE REAR OF PLAYSET

STEP 56: INSTALLING THE TELESCOPE

- 1: WITH THE 1-1/4" WOOD SCREWS PROVIDED IN THE TELESCOPE BAG, FASTEN ONE OF THE SQUARE TELESCOPE BRACKETS TO THE FRONT TOP PANEL BOARD, BETWEEN THE TWO PANEL SLATS.
- 2: PLACE THE TELESCOPE STAND AND TELESCOPE INTO THE SLOT OF THE TELESCOPE BRACKET.
- 3: FASTEN THE REMAINING TELESCOPE BRACKET TO THE OPPOSITE SIDE THAT THE FIRST TELESCOPE BRACKET WAS INSTALLED ON WITH 1-1/4" WOOD SCREWS.

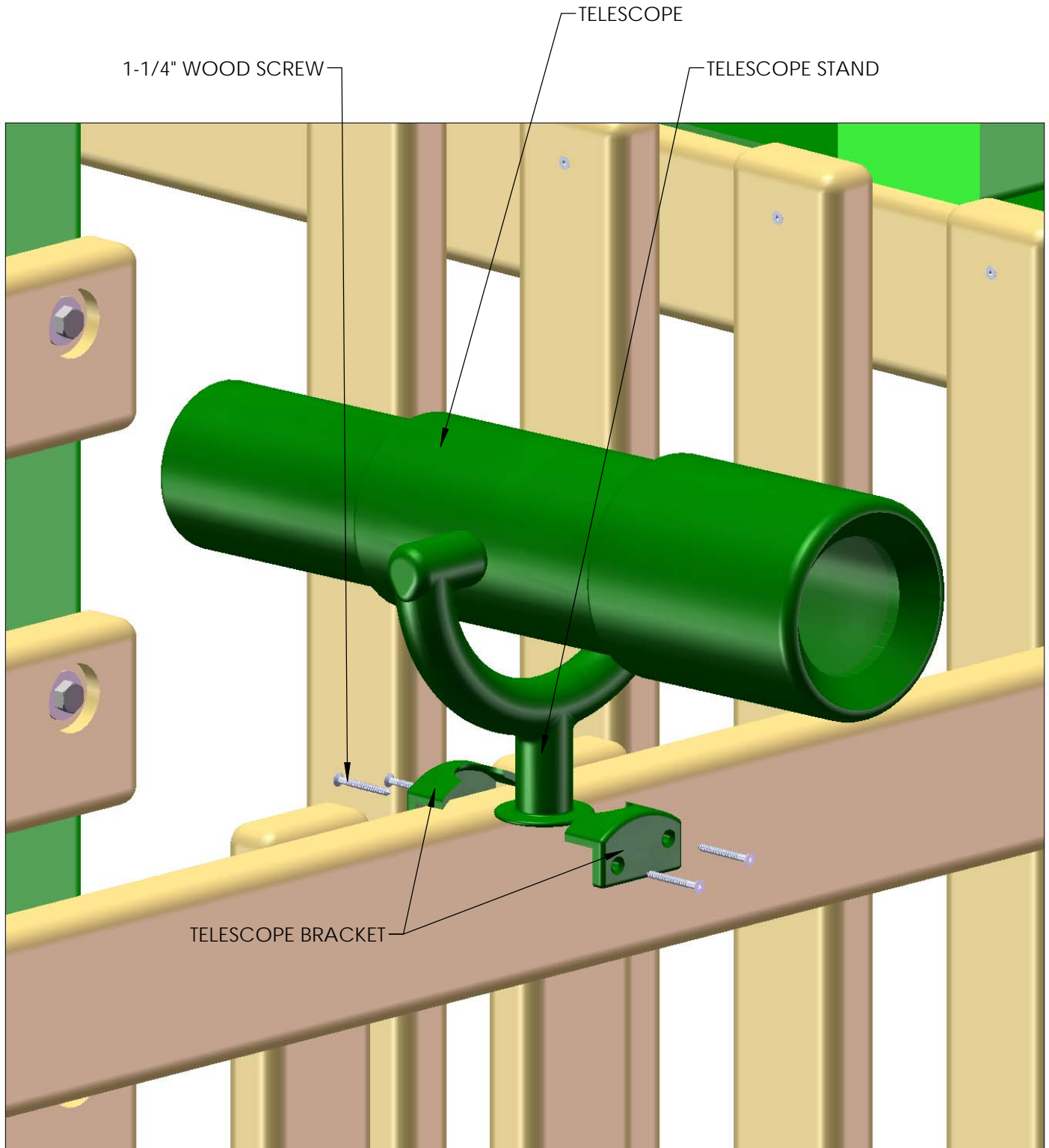

STEP 57: RAD RIDE

1: LOCATE THE LEFT AND RIGHT ENTRANCE SECTION.

2: FASTEN THE LEFT AND RIGHT SECTIONS TOGETHER ALONG THE RIBS OF THE SLIDE SECTION WITH 5/16" X 3/4" HEX BOLTS, 5/16" WASHERS, AND 5/16" LOCK NUTS.

3: DO NOT FULLY TIGHTEN BOLTS UNTIL THE ENTIRE UNIT HAS BEEN FULLY ASSEMBLED. THIS WILL ALLOW FOR NECESSARY FLEX OF THE SLIDE BODY WHILE ASSEMBLING.

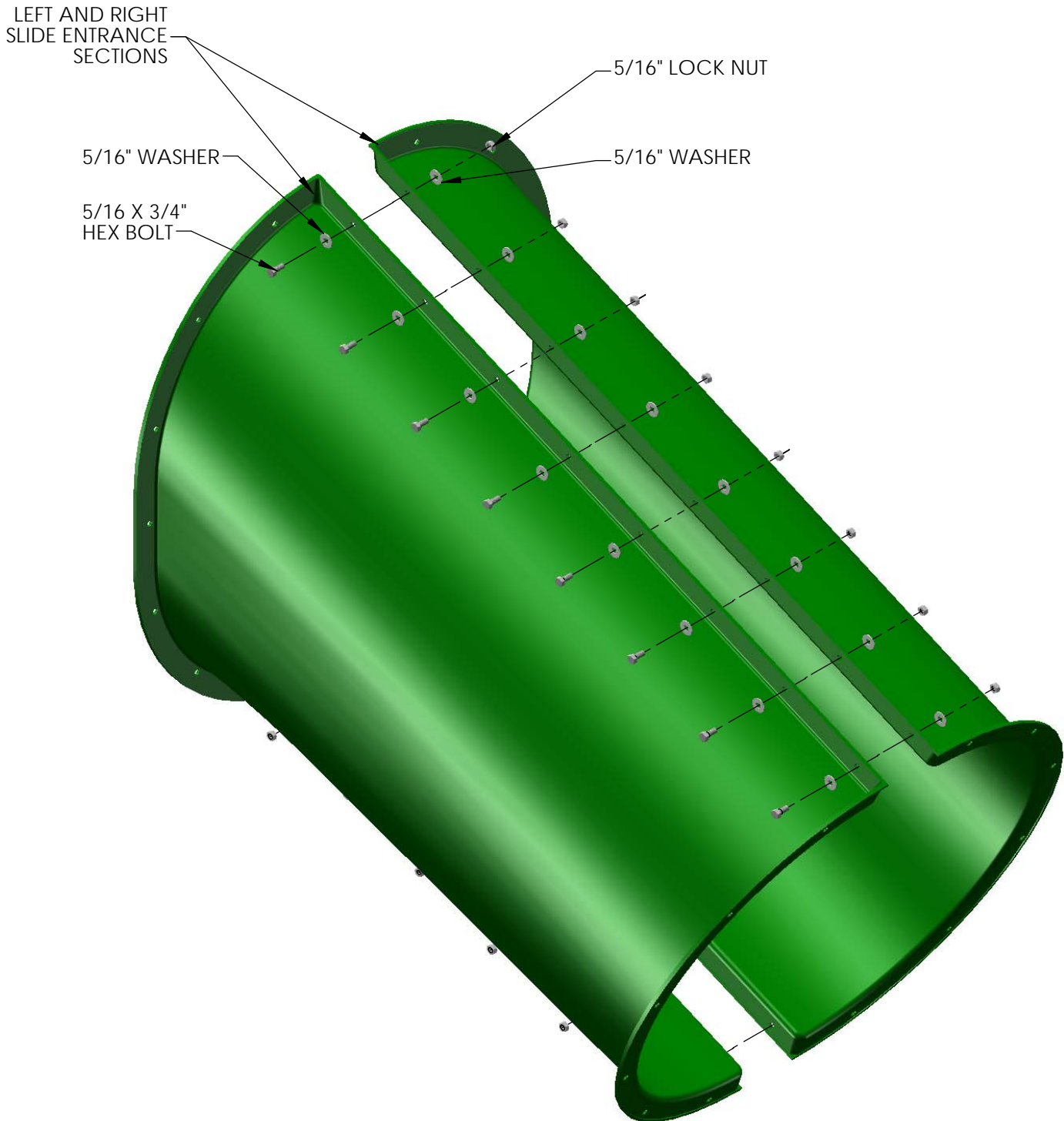

STEP 58: ASSEMBLING THE SLIDE SECTIONS

- 1: LOCATE TWO 90° SLIDE SECTIONS. FASTEN THE TWO PIECES TOGETHER ALONG THE RIBS WITH 5/16 X 3/4" HEX BOLTS, 5/16" WASHERS, AND 5/16" LOCK NUTS. REPEAT THIS PROCESS TO MAKE TWO SLIDE BODY SECTIONS.
- 2: WITH THE REMAINING 90° SLIDE SECTION AND THE 90° EXIT SECTION, YOU WILL ASSEMBLE THE SLIDE EXIT. THE SLIDE EXIT IS ASSEMBLED THE SAME WAY THAT THE OTHER 90° SECTION WAS ASSEMBLED.
- 3: DO NOT FULLY TIGHTEN HARDWARE UNTIL ENTIRE SLIDE HAS BEEN ASSEMBLED.

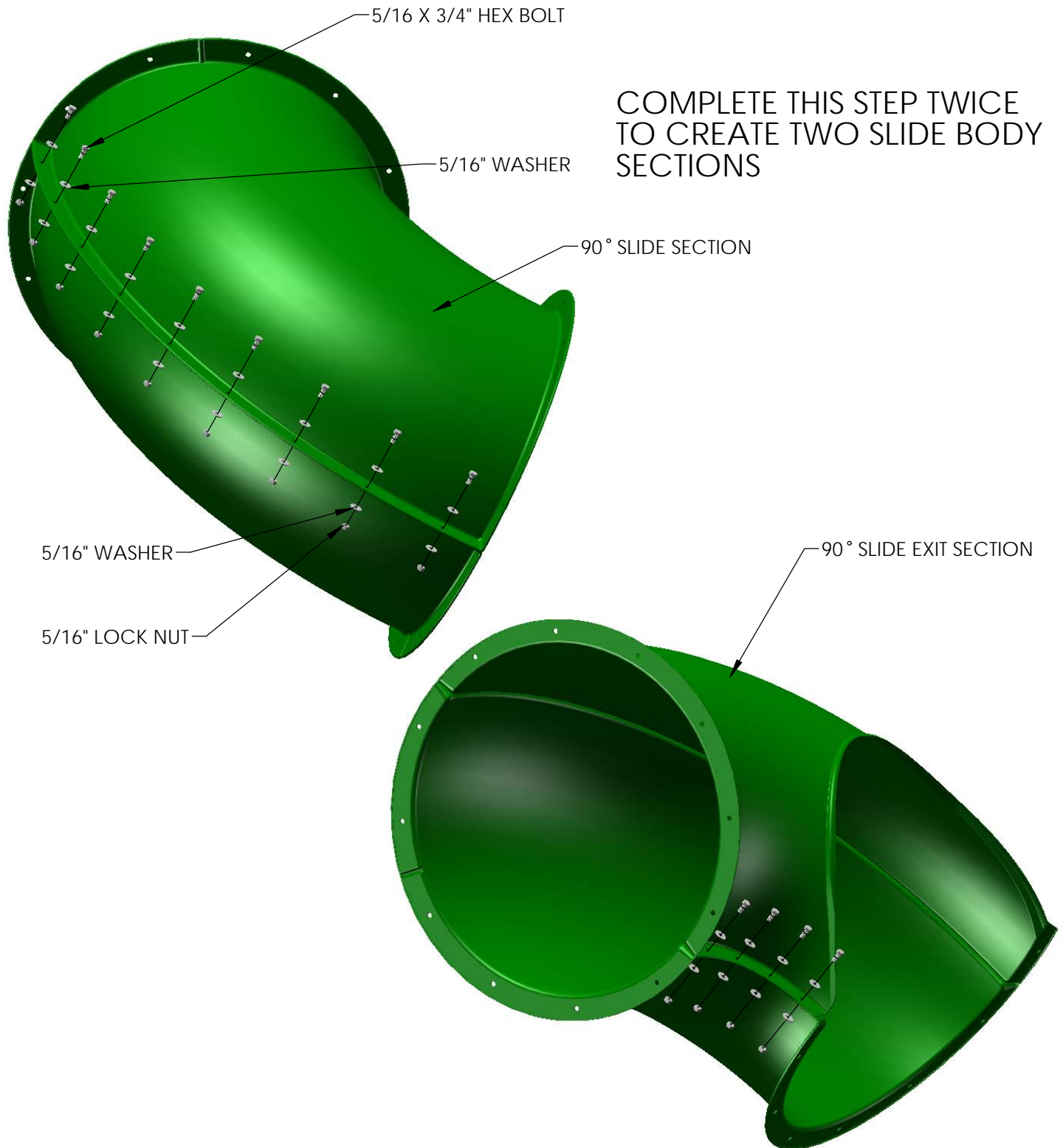

STEP 59: ATTACHING SLIDE SECTIONS

1: THE BEST WAY TO PUT THE SLIDE SECTIONS TOGETHER IS TO USE THE MIDDLE OF THE SLIDE BODY AS A REFERENCE. PLACE ONE OF THE SLIDE BODY SECTIONS ON THE GROUND AND MAKE SURE THAT THE INNER RIB IS FACING TOWARDS YOU.

2: TAKE THE OTHER SLIDE BODY ASSEMBLY AND LAY IT BESIDE THE MIDDLE SECTION OF THE SLIDE BODY. LINE UP THE HOLES AND RIBS SO THAT THE TWO PIECES FORM A GIANT "U" SHAPE ON THE GROUND. NOW ROTATE THE SLIDE BODY ASSEMBLY ON THE LEFT UPWARDS UNTIL THERE IS A TWO HOLE GAP BETWEEN THE INNER RIBS OF THE SLIDE BODY SECTIONS. ATTACH THE SLIDE SECTIONS WITH 5/16 X 3/4" HEX BOLTS, 5/16" WASHERS, AND 5/16" LOCK NUTS.

3: USING THE SAME APPROACH THAT WAS USED FOR THE SLIDE BODY ASSEMBLIES, PLACE THE SLIDE EXIT SECTION NEXT TO THE SLIDE BODY SECTION. THE INNER RIB OF THE SLIDE EXIT WILL ROTATE DOWNWARD UNTIL THERE IS A TWO HOLE GAP BETWEEN THE INNER RIBS OF THE MIDDLE SLIDE BODY ASSEMBLY AND THE SLIDE EXIT SECTION. ATTACH THE SLIDE SECTIONS WITH 5/16 X 3/4" HEX BOLTS, 5/16" WASHERS, AND 5/16" LOCK NUTS.

4: DO NOT FULLY TIGHTEN HARDWARE UNTIL ENTIRE SLIDE HAS BEEN ASSEMBLED.

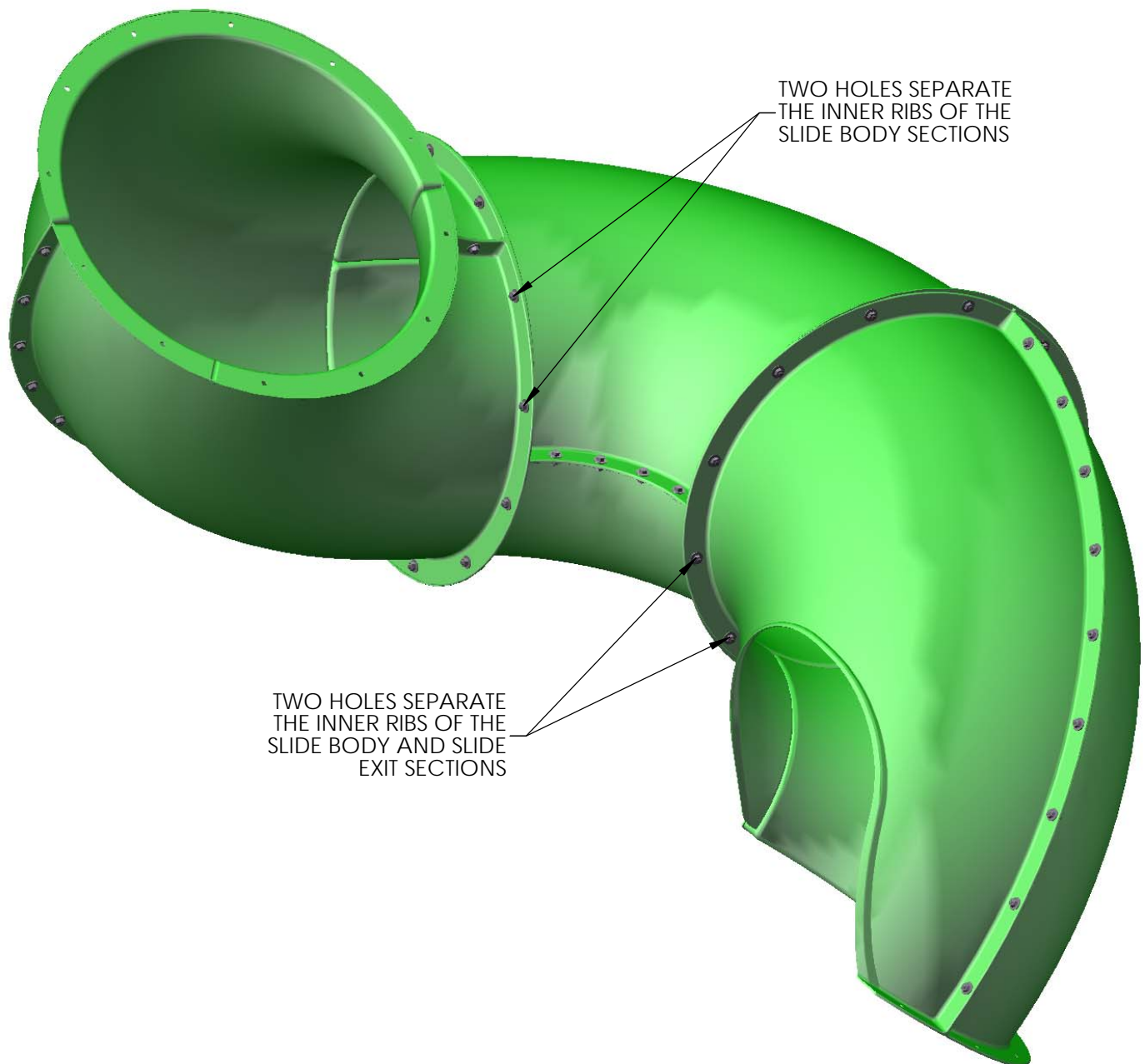

STEP 60: ATTACHING THE FOOT STAND

- 1: PLACE THE FOOTER SUPPORT ON THE INSIDE OF THE FOOT STAND, NOT BETWEEN THE EXIT SECTION AND THE FOOT STAND.
- 2: ATTACH THE SLIDE EXIT SECTION TO THE FOOT STAND AND FOOTER SUPPORT WITH 5/16 X 3/4" HEX BOLTS, 5/16" WASHERS, AND 5/16" LOCK NUTS.
- 3: DO NOT FULLY TIGHTEN HARDWARE UNTIL ENTIRE SLIDE HAS BEEN ASSEMBLED.

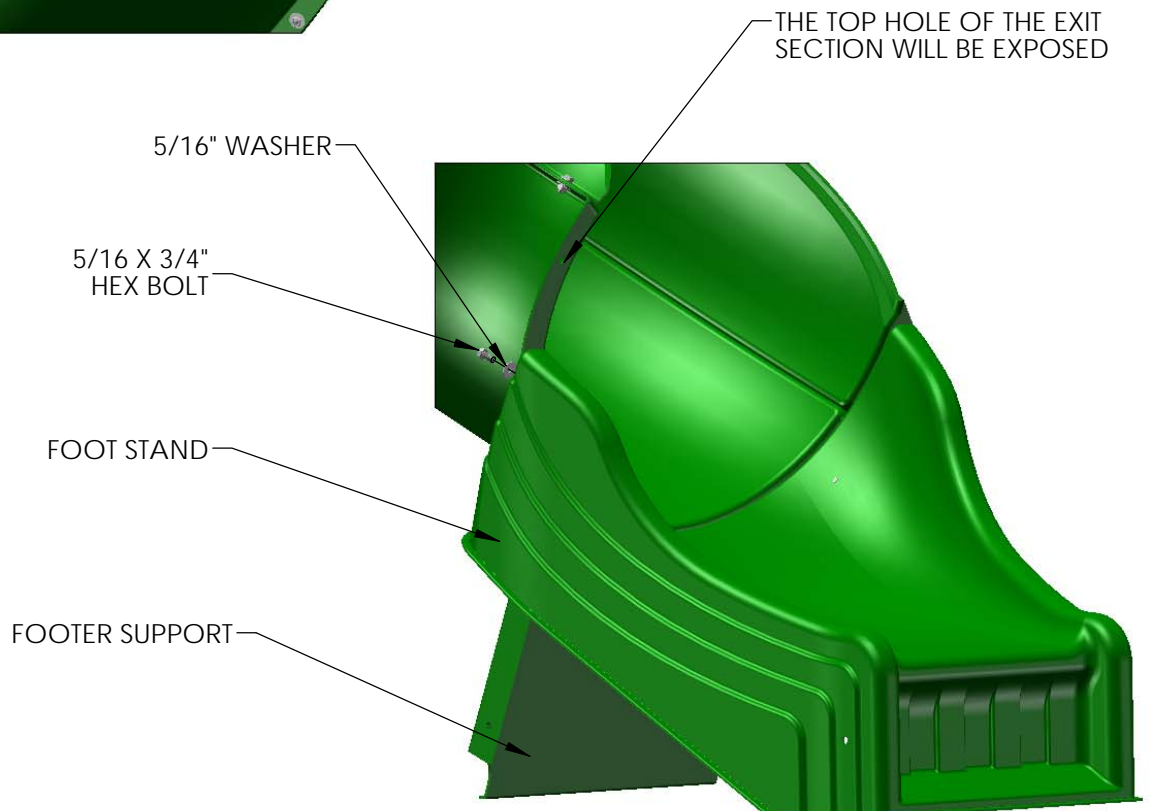

STEP 61: ATTACHING THE FOOTER STRAPS

- 1: PLACE ONE END OF THE FOOTER STRAP INSIDE THE SIDE OF THE FOOT STAND AND THE OTHER END INSIDE THE FOOTER SUPPORT.
- 2: ATTACH USING 5/16 X 3/4" HEX BOLTS, 5/16" WASHERS, AND 5/16" LOCK NUTS.
- 3: DO NOT FULLY TIGHTEN HARDWARE UNTIL ENTIRE SLIDE HAS BEEN ASSEMBLED.

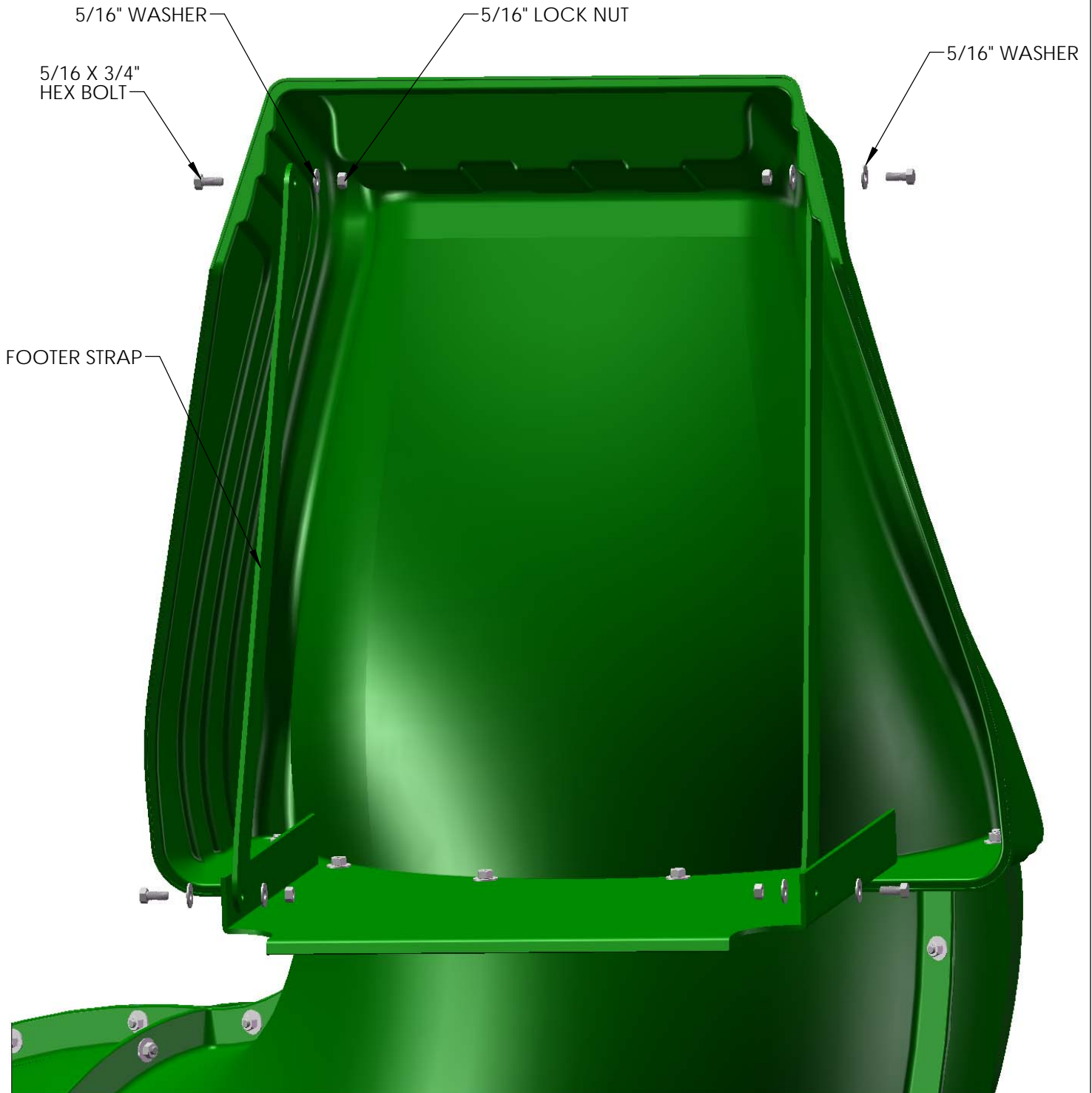

STEP 62: ATTACHING THE SLIDE BODY TO THE SLIDE ENTRY

- 1: ATTACH THE SLIDE ASSEMBLY TO THE SLIDE ENTRY ASSEMBLY WITH 5/16 X 3/4" HEX BOLTS, 5/16" WASHERS, AND 5/16" LOCK NUTS.
- 2: LEAVE A GAP OF TWO HOLES WHEN ATTACHING THE SLIDE BODY TO THE SLIDE ENTRY.
- 3: DO NOT FULLY TIGHTEN HARDWARE UNTIL ENTIRE SLIDE HAS BEEN ASSEMBLED.

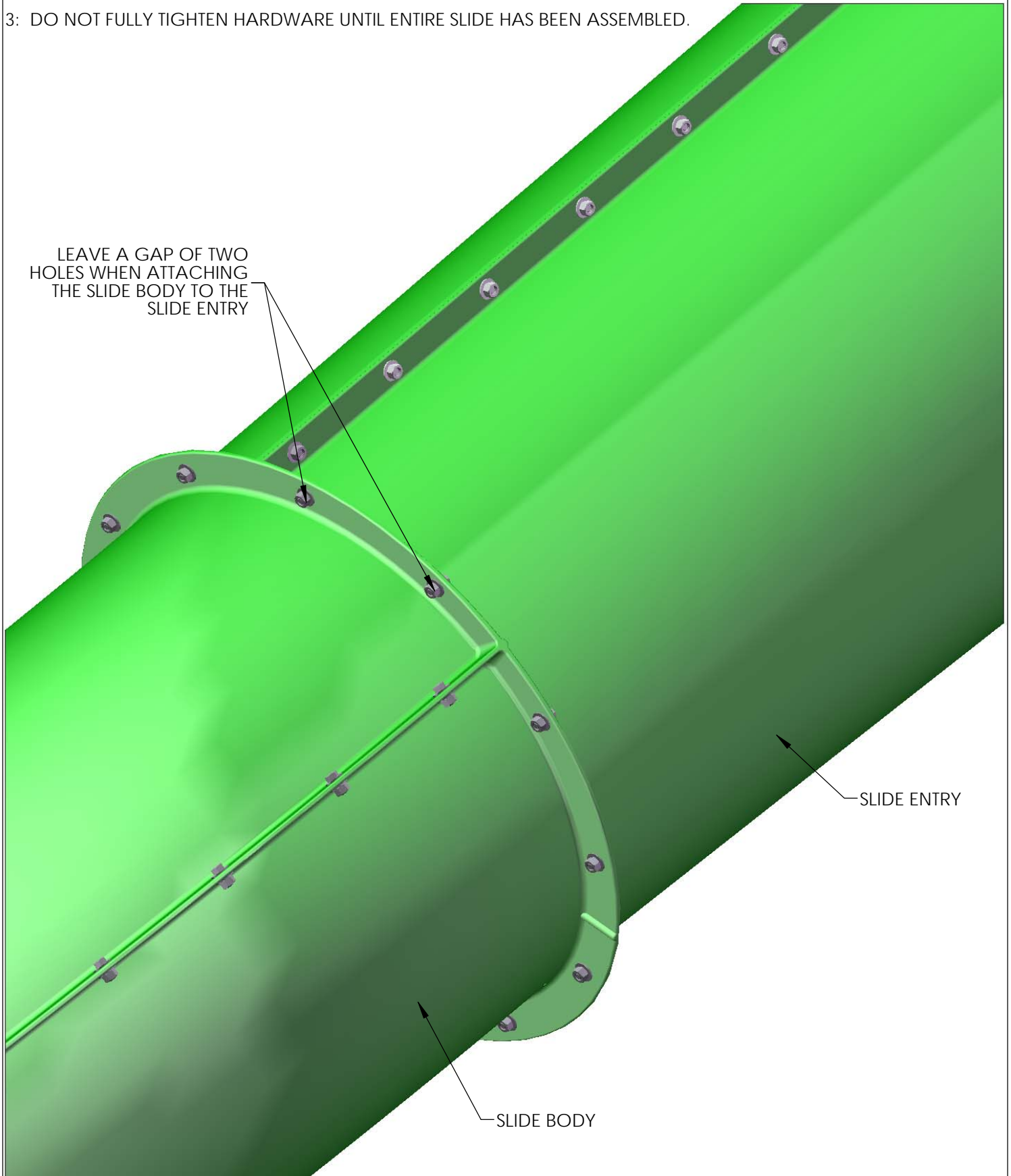

STEP 63: SLIDE ENTRY PLATE

1: LOCATE THE SLIDE ENTRY PANEL AND THE SLIDE ENTRANCE SECTION ASSEMBLY.

2: ATTACH THE PANEL TO THE SLIDE ENTRANCE SECTION WITH EIGHT 5/16 X 3/4" HEX BOLTS, SIXTEEN 5/16" WASHERS, AND EIGHT 5/16" LOCK NUTS. SEE BELOW FOR ATTACHMENT LOCATIONS.

3: LIKE THE PREVIOUS STEP, DO NOT FULLY TIGHTEN THE HARDWARE UNTIL THE SLIDE IS FULLY ASSEMBLED AND ATTACHED TO THE FORT.

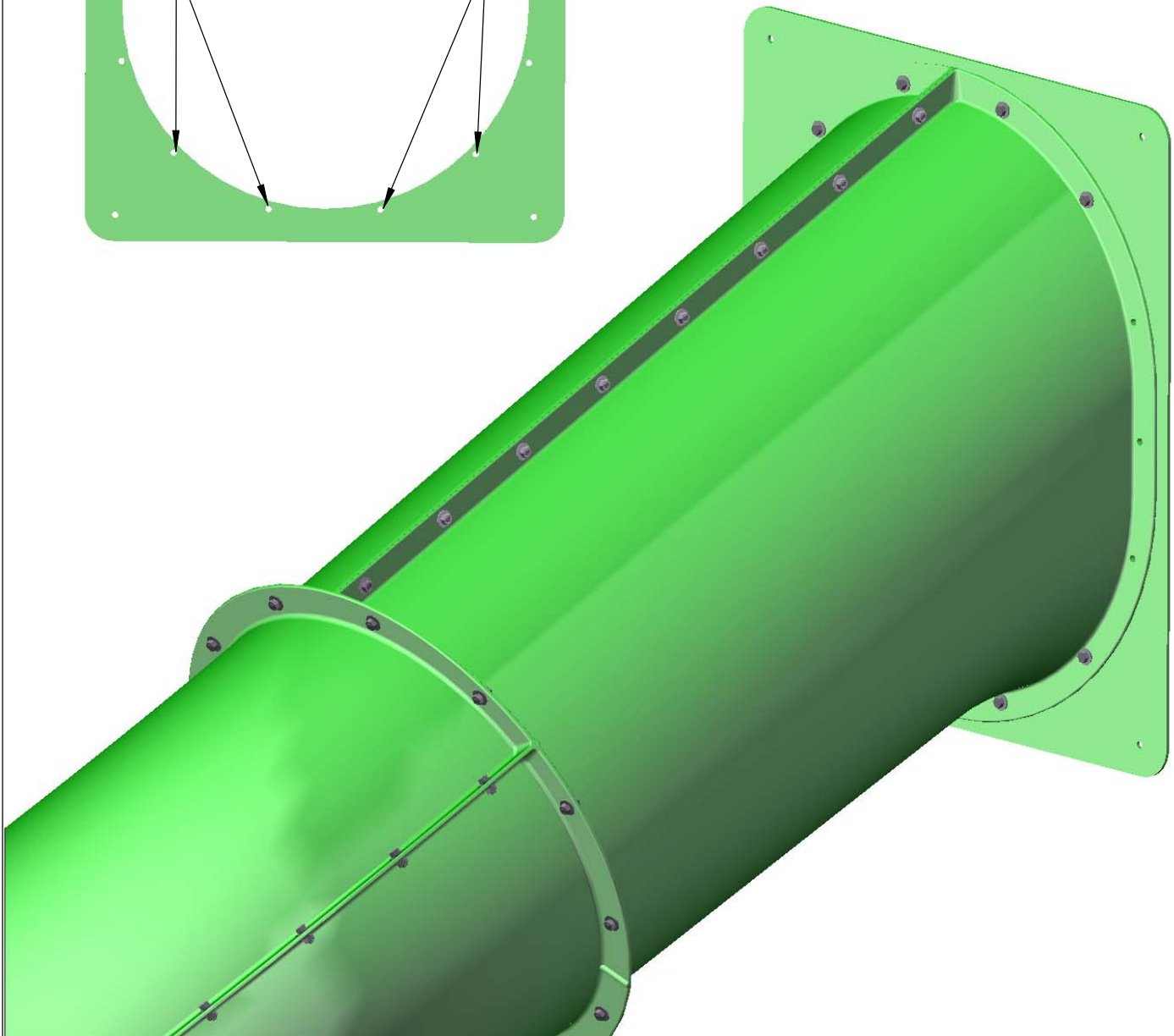
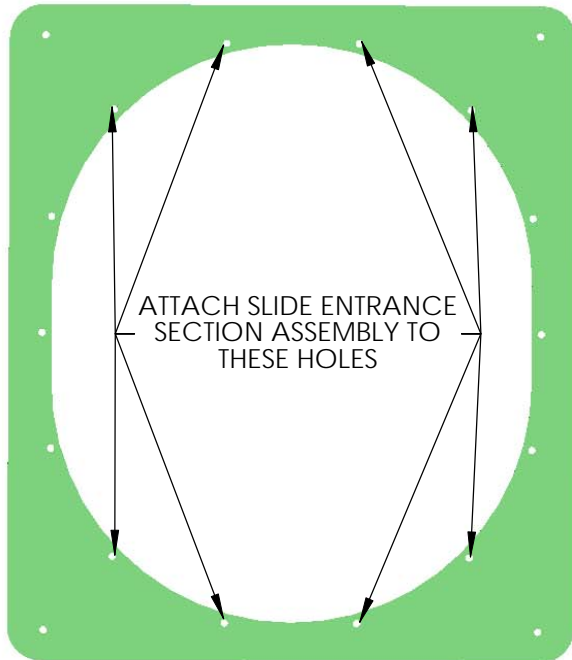

STEP 64: ATTACHING THE SLIDE ENTRY

1: ATTACH THE SLIDE ENTRY ASSEMBLY TO THE CORNER POST AND LAG POST OF THE UPPER LEVEL WITH 5/16 X 3-1/2" LAG SCREWS AND 5/16" WASHERS IN THE REMAINING HOLES OF THE SLIDE ENTRY PLATE.

2: TIGHTEN ALL HARDWARE ON THE SLIDE.

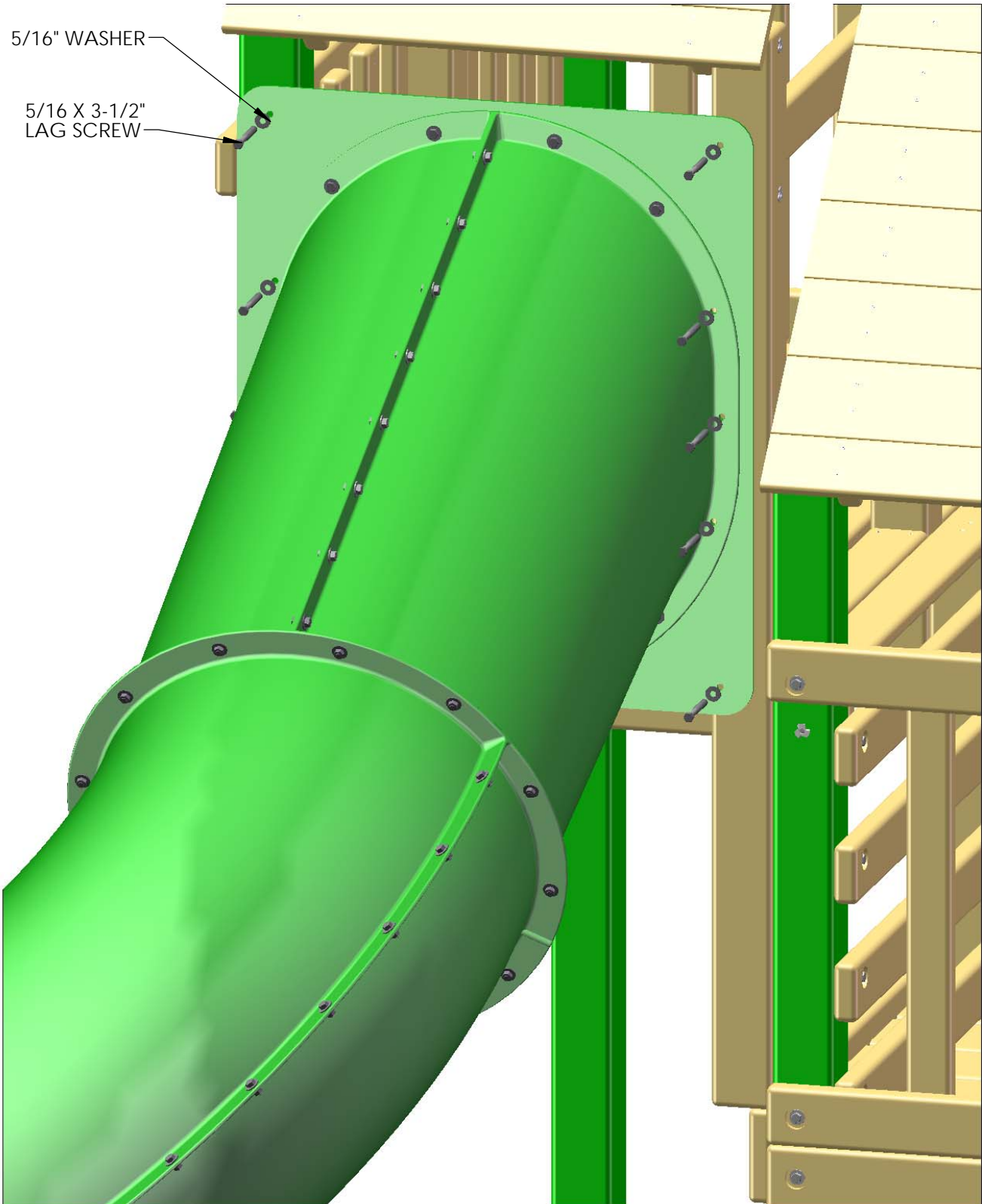

STEP 65: TIC TAC TOE

- 1: LOCATE THE GREEN DOWELS AND MATCH THEM AS FOLLOWS: ONE THREADED STUD END, AND ONE THREADED INSERT.
- 2: SCREW THE STUDS INTO THE INSERTS UNTIL TIGHT.
- 3: REPEAT STEPS 1 AND 2 WITH THE REMAINING TWO SETS



- 4: LOCATE ONE OF THE GREEN BRACKETS AND PLACE THE DOWELS IN AS SHOWN.

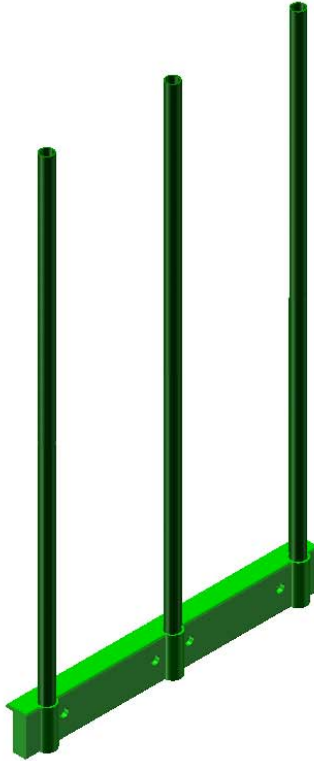

- 5: LOCATE THE BLUE COLLARS AND SLIDE THEM OVER THE DOWELS

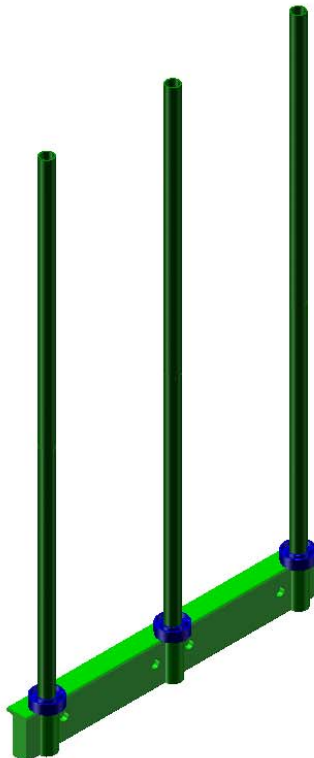

STEP 66: TIC TAC TOE

- 1: LOCATE THE TIC-TAC-TOE TUMBLERS AND PLACE ONE ON EACH DOWEL ABOVE THE COLLARS.
- 2: CONTINUE PLACING COLLARS AND TUMBLERS ON THE DOWELS UNTIL NONE REMAIN.

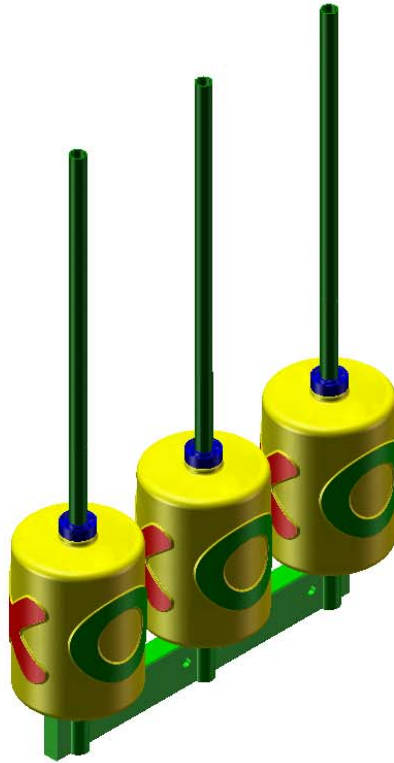

- 3: LOCATE THE GREEN BRACKET AND PLACE ON TOP OF ASSEMBLY. LINE UP THE HOLES IN THE BRACKET WITH THE DOWELS ON THE UNIT.



STEP 67: TIC-TAC-TOE PANEL

- 1: CENTER THE 1-3/4 X 1-1/2 X 10-3/4" BLOCK BETWEEN THE PANEL SLATS ON THE SLIDE SIDE PANEL WALL, 4" FROM THE DECK, AND ATTACH WITH 2" WOOD SCREWS.
- 2: PLACE THE TIC-TAC-TOE PANEL ON THE PREVIOUSLY INSTALLED BOARD, AND THEN PLACE THE OTHER 1-3/4 X 1-1/2 X 10-3/4" BLOCK AT THE TOP OF THE TIC-TAC-TOE PANEL.
- 3: WITH A PENCIL, MAKE A MARK AT THE TOP OF THE BOARD AND SET THE ASSEMBLY ASIDE.
- 4: PLACE THE TIC-TAC-TOE PANEL BLOCK BACK AT THE MARK THAT WAS PREVIOUSLY MADE, AND ATTACH IT WITH 2" WOOD SCREWS.
- 5: PLACE THE TIC-TAC-TOE PANEL ON THE INSTALLED BLOCKS, AND ATTACH IT TO THE BLOCKS WITH THE PROVIDED WOOD SCREWS.



STEP 68: DORMER

- 1: FIND TWO LEFT SIDE AND TWO RIGHT SIDE DORMER ROOF ASSEMBLIES.
- 2: FIND TWO DORMER SUNRAY ASSEMBLIES.
- 3: PLACE THE LEFT AND RIGHT ROOF ASSEMBLIES ON THE BACK SIDE OF THE DORMER SUNRAY ASSEMBLY AS SHOWN BELOW.
- 4: ATTACH THE DORMER ROOF SIDES TO THE DORMER SUNRAY WITH 1-1/4" WOOD SCREWS FROM THE ROOF BOARDS OF THE ROOF ASSEMBLIES.

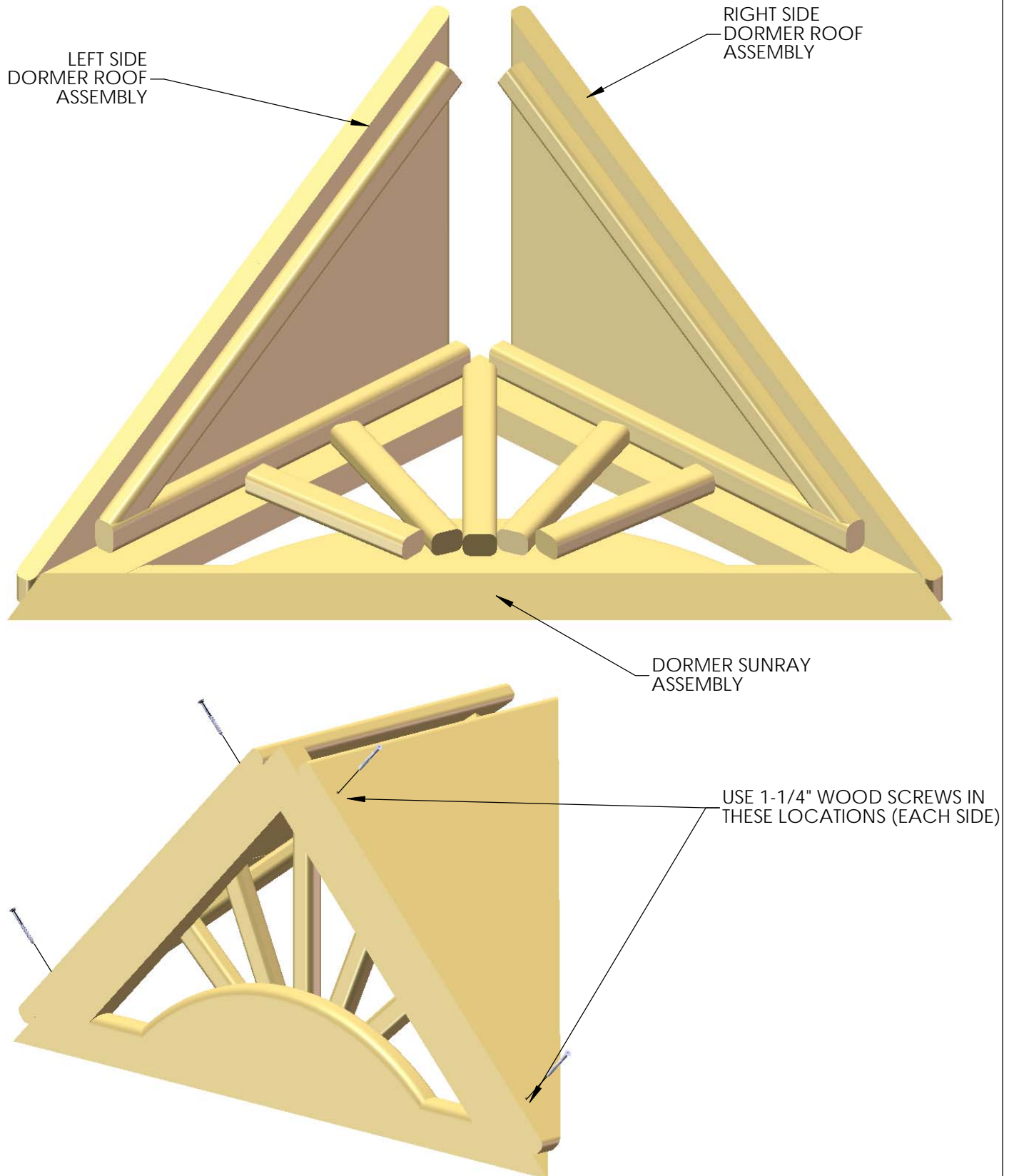

STEP 69: DORMER

1: FIND THE DORMER ROOF PEAK ASSEMBLY.

2: PLACE THE ROOF PEAK ASSEMBLY IN THE TOP OF THE ROOF AND FASTEN WITH 1-1/2" WOOD SCREWS.

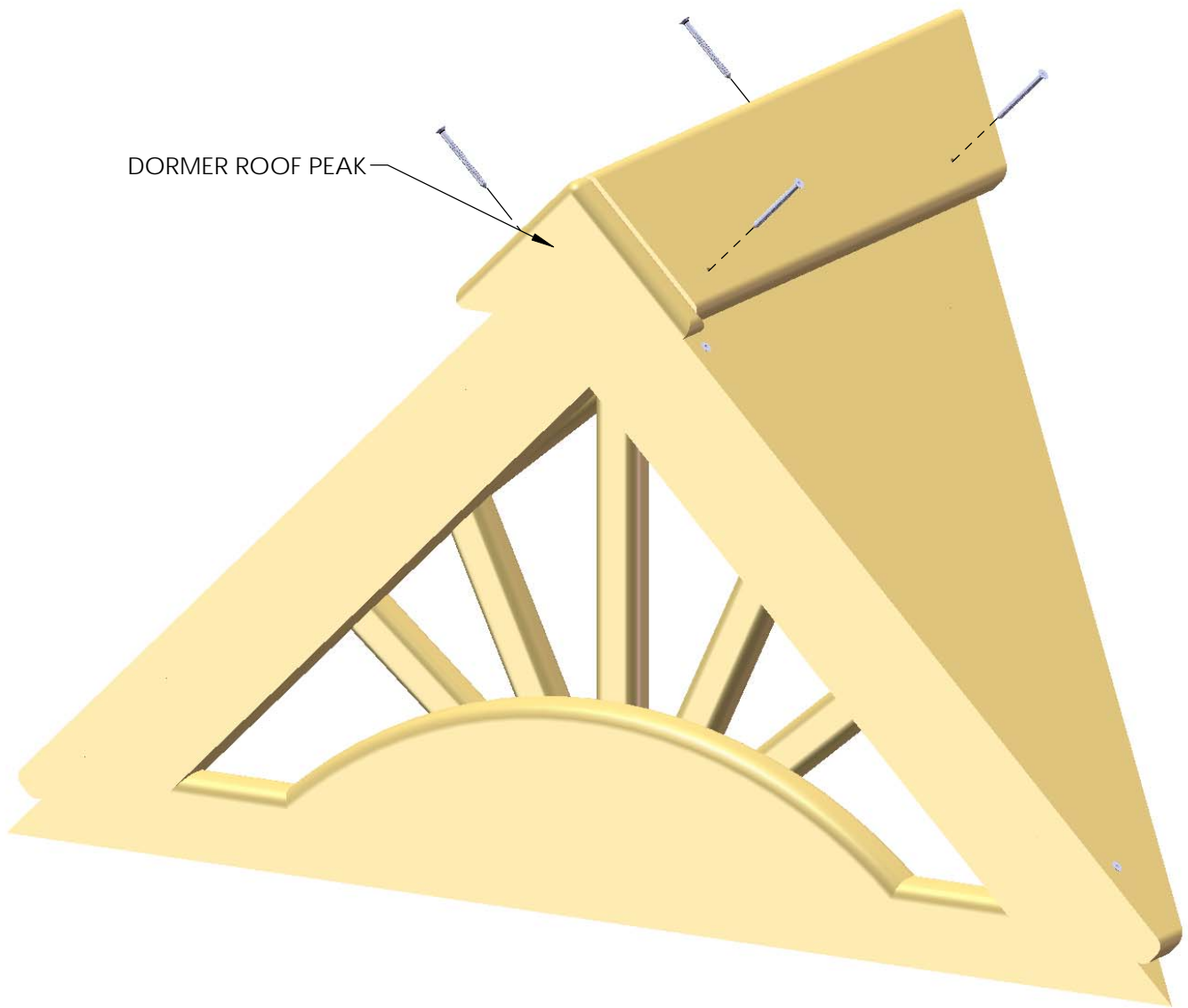

STEP 70: DORMER

- 1: CENTER THE DORMER ASSEMBLIES ON THE ROOF.
- 2: USE 2" WOOD SCREWS TO FASTEN THE DORMERS TO THE ROOF.

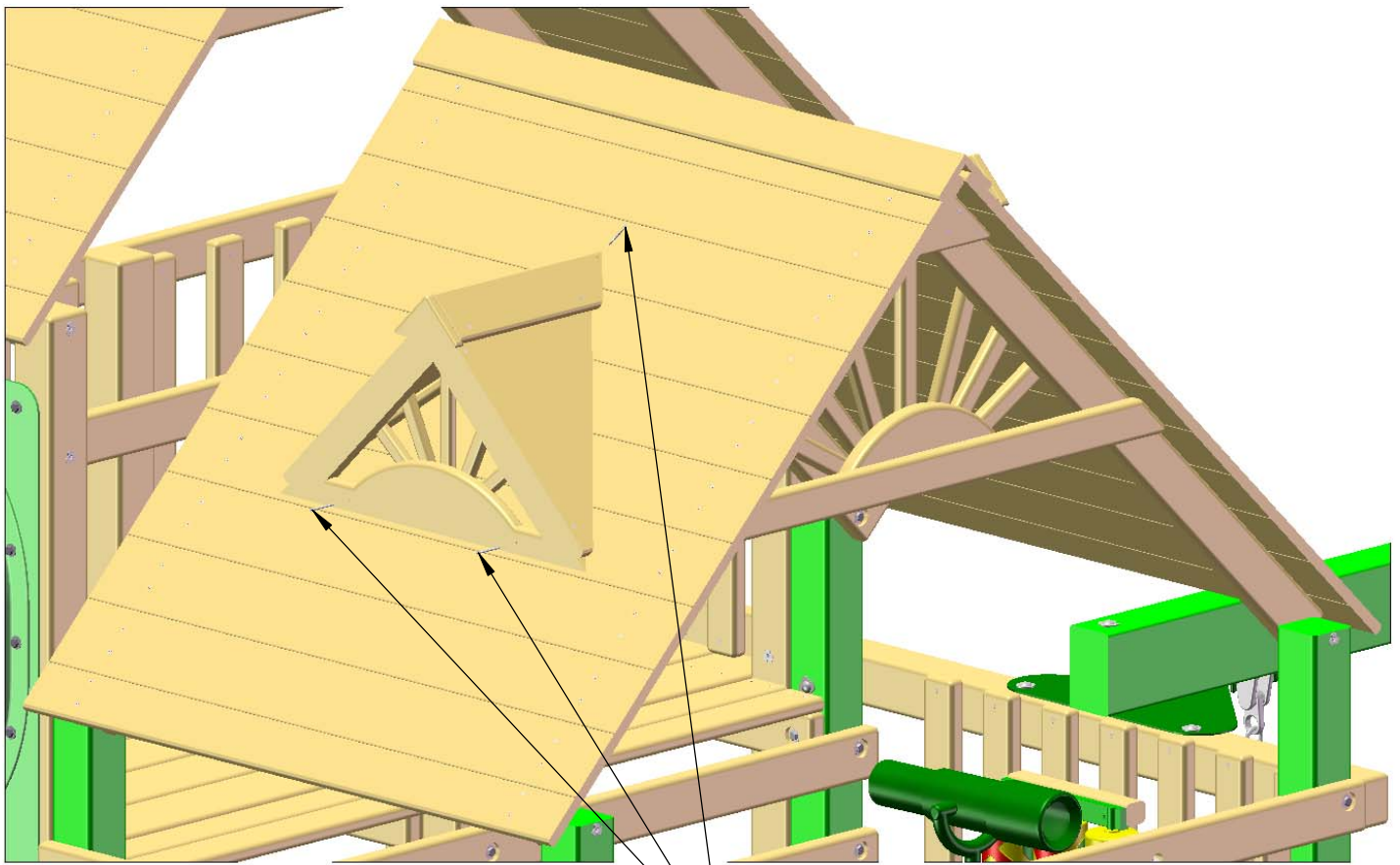

USE 2" WOOD SCREWS
IN THESE LOCATIONS

STEP 71: CHIMNEY

1: FIND THE FRONT AND LEFT SIDE OF THE CHIMNEY.

2: ATTACH THE FRONT AND LEFT SIDES OF THE CHIMNEY WITH A 2" WOOD SCREW.

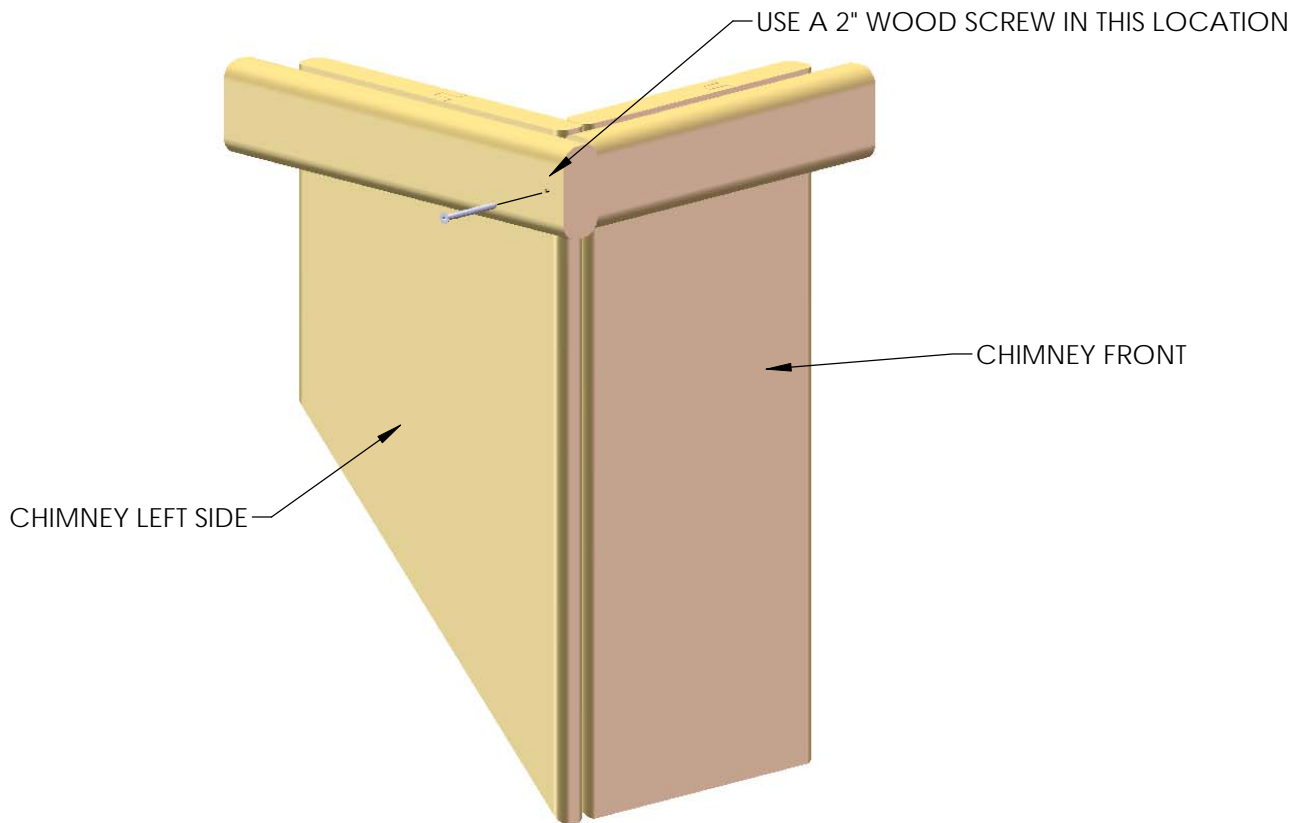

1: FIND THE REAR AND RIGHT SIDE OF THE CHIMNEY.

2: ATTACH THE REAR AND RIGHT SIDES OF THE CHIMNEY WITH A 2" WOOD SCREW.

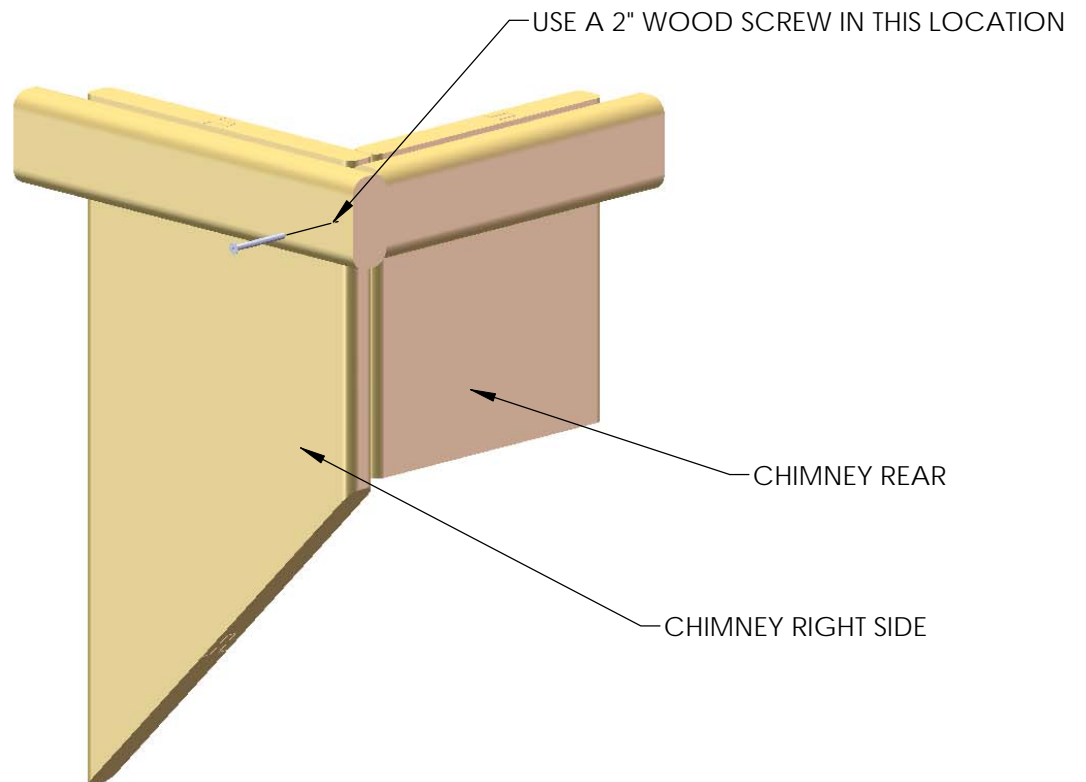

STEP 72: CHIMNEY

1: ATTACH THE CHIMNEY SIDES FROM THE PREVIOUS SIDES TO FORM THE CHIMNEY WITH 2" AND 1-1/4" WOOD SCREWS.

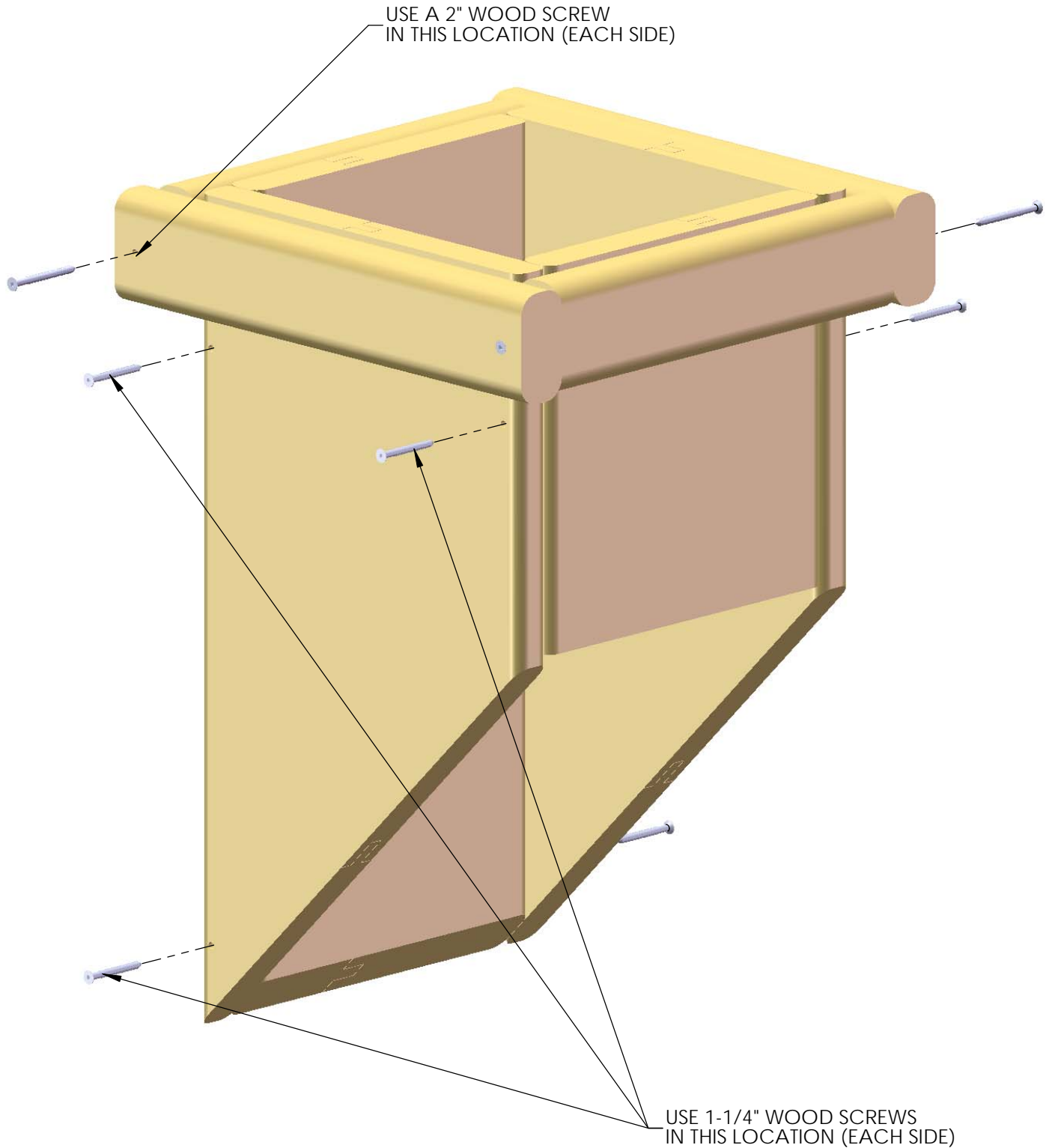

STEP 73: CHIMNEY

- 1: FASTEN THE 5/4 X 3 X 6-3/4" CHIMNEY MOUNTING BLOCK TO THE ROOF WITH 1-1/2" WOOD SCREWS. YOU CAN PLACE THE BLOCK AT ANY DESIRED PLACE ON THE ROOF. USE THE DIAGRAM BELOW AS A GUIDE AS TO WHERE YOU MIGHT INSTALL YOUR CHIMNEY.
- 2: AFTER INSTALLING THE CHIMNEY MOUNTING BLOCK, PLACE THE CHIMNEY ASSEMBLY ON THE ROOF SO THAT THE INSIDE OF THE BACK WALL RESTS AGAINST THE BLOCK.
- 3: FASTEN THE CHIMNEY TO THE CHIMNEY MOUNTING BLOCK WITH A 1-1/4" WOOD SCREW IN EACH SIDE.

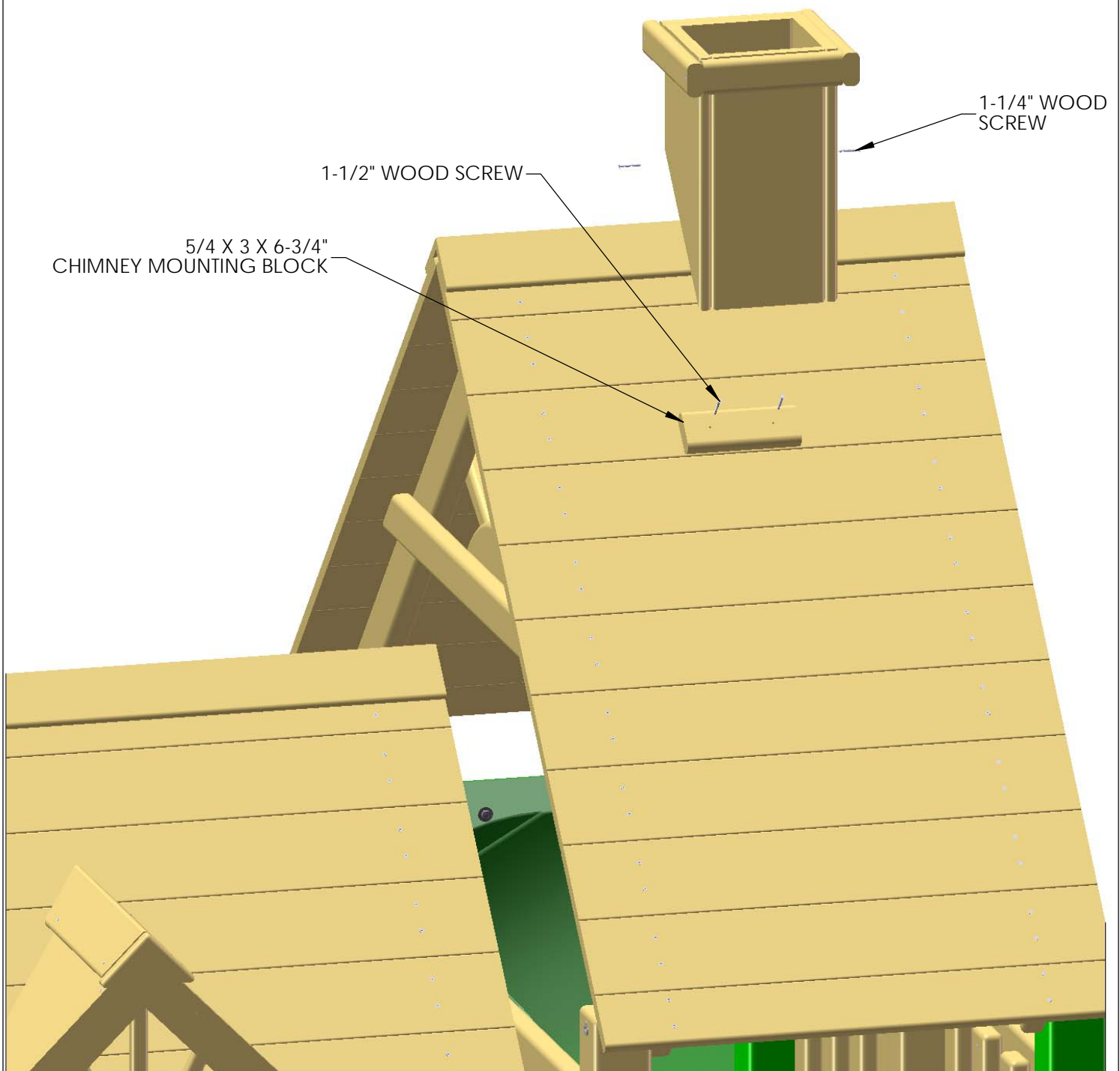

WARRANTY REGISTRATION CARD – BLUE RIDGE RETREAT

Name: _____

Address: _____

City, State, Zip: _____

Email: _____

Date of Purchase: _____

Place of Purchase: _____

City, State, Zip: _____

Please, check the boxes below.

Your age?

- 18-25 26-30 31-35 36-40 41-45 46-50 51-55 56-60
 61-65 66+

How old are your children?

- 2-3 4-5 6-7 8+

How would you rate the quality of our product?

- Excellent Above average Average Below average Poor

Would you recommend this product?

- Yes No

Comments:

Thank you for registering with gorilla playsets™! The information you provided will be kept confidential and will ONLY be used to better serve our customers. Remove this page from the manual and mail to the address below.

Thank you from everyone here at gorilla playsets™!

Mail to:
Gorilla Playsets
190 Etowah Industrial Court
Canton, GA 30114

or fax:
(678) 880-3329