



Playmaker

Model: 2401

(BOXES: 2401-1, 2401-2 &
Slide Box)

Copyright © 2018 Gorilla Playsets
All Rights Reserved



51-1043-T

190 Etowah Industrial Court
Canton, GA 30114

www.gorillaplaysets.com



Please inspect and inventory all parts immediately upon accepting delivery. Use the inventory pages in the manual to make sure you have received all necessary parts. The quickest method to get any parts that are missing or damaged is to use our “Quick Response Center” located at:

www.gorillaplaysets.com/support

DO NOT RETURN THIS PRODUCT TO THE RETAILER OR CONTACT THE RETAILER DIRECTLY. THE RETAILER DOES NOT STOCK COMPONENTS.

PLEASE RETAIN ALL INSTRUCTIONS FOR FUTURE REFERENCE. KEEP THEM IN A SAFE PLACE WHERE YOU CAN REFER TO THEM AS NEEDED. CHECK FOR REVISED INSTRUCTIONS AT:

www.gorillaplaysets.com/manuals

GORILLA PLAYSETS WARRANTY – 2018

Gorilla Playsets® (“Gorilla”) warrants its play sets to be free from defects in workmanship and materials, under normal use and conditions, for 10 years for above ground structural wood components and for one year for all other components (e.g., swings, hardware, plastics, tarps, rope ladder, etc.).

Gorilla warrants all remaining products, including but not limited to its, Malibu Playhouse, Free Standing Swing Set, Free Standing Tire Swing, See-Saw, Children’s Picnic Table with Umbrella, Play-Zee-Bo™, Cedar Toy Chest, Interlocking Sandbox and spring riders to be free from defects in workmanship and materials, under normal use and conditions, for a period of 1 year.

Cosmetic imperfections and natural tendencies of wood such as peeling, splintering, warping, seasonal checking or cracking, knots or knot holes, etc. are normal characteristics of all outdoor wooden play equipment and are not covered by this warranty. Checks or cracks in wood components that do not affect the intended function of the part, piece or overall swing set are not covered under this warranty.

Wood rot or decay that develops because the product was installed in an area with poor drainage is not covered under this warranty. Lumber that has been damaged by wood boring bees, or conditions that develop as a result of faulty or improper installation of the product, are not covered by this warranty. Fading of stain, discoloration or mold on any wood part or accessory is not covered by this warranty. Cracks in plastic components, surface rust on hardware and chips on powder coated materials are not considered defects in material as long as they do not affect the functionality or structural integrity of the part or component.

It is the owner’s responsibility to maintain the swing set. **This includes but is not limited to staining and sealing the lumber as needed and regular inspection to be sure all hardware is tight.** Instructions for proper maintenance can be found on Gorilla’s website. Imperfections or conditions that develop because of a failure to properly maintain the swing set are not covered by this warranty.

Gorilla will, at its discretion, replace any above ground part within the stated warranty period that is defective in workmanship or materials. This decision is subject to verification of the defect, which, at Gorilla’s discretion, may be accomplished by submitting photographs or by delivery of the defective part to Gorilla Playsets • 190 Etowah Industrial Ct. • Canton, GA 30114 • 1-800-882-0272 Monday to Friday 9AM-5PM EST. Any warranty claim must include proof of purchase, including the date of purchase. **In addition, within the first 30 days from the date of purchase, Gorilla will replace any parts discovered to be missing from or damaged in the original packaging.**

This warranty is valid only if the product is used for the purpose for which it was designed and installed at a residential, single-family dwelling. This warranty is void if the product is used in a commercial, institutional or multi-family setting. **This warranty does not cover normal wear and tear or (a) products that have been damaged by acts of God and/or nature, negligence, misuse or accident; (b) products that have been modified or repaired by unauthorized persons; (c) the cost of labor; or (d) the cost of shipping any replacement product or part.**

GORILLA DISCLAIMS ALL OTHER REPRESENTATIONS AND WARRANTIES OF ANY KIND, EXPRESSED, IMPLIED, STATUTORY OR OTHERWISE, INCLUDING THE IMPLIED WARRANTIES OF MERCHANTABILITY AND FITNESS FOR A PARTICULAR PURPOSE. GORILLA WILL NOT BE LIABLE FOR ANY INCIDENTAL OR CONSEQUENTIAL DAMAGES. This warranty is non-transferable and does not extend to the owners of the product subsequent to the original purchaser. Some states do not allow limitations on implied warranties or exclusion of incidental or consequential damages, so these restrictions may not be applicable to you. This warranty gives you specific legal rights. You may also have other rights which vary from state to state.

IMPORTANT SAFETY GUIDELINES

This product is recommended for use by children ages 3-11. This product is intended for residential use only and not intended for use in any public setting. A safety surface such as mulch or recycled tire should be used under the play set to prevent injury from falls. Also a 6 foot safety zone should be used around the entire play set.

As with any home project, good judgment and respect for power tools will greatly reduce the risk of injury. Gorilla recommends you follow all tool manufacturers' safety guidelines. Always wear eye protection and safety gloves to prevent injury. In several phases of construction two people may be required for lifting and securing of lumber. While the play set is being constructed, please keep children off the equipment until the project is complete. Bolts and screw heads should be checked regularly for tightness. The ground ladder, rope ladder, slide, swings and other areas where children spend a majority of their playtime should be checked more frequently.

Gorilla shall not be liable for incidental, indirect or consequential damages or injuries that result from building and/or playing on our play sets. Adult supervision is recommended anytime a play set is being used.

WEIGHT LIMITS FOR GORILLA PLAYSETS

- FORT PLATFORMS: 800 LBS. TOTAL WEIGHT
- SWING BELT: 225 LBS.
- TANDEM SWINGS: 70 LBS. PER CHILD. UP TO 140 LBS. TOTAL WEIGHT.
- TRAPEZE: 125 LBS.
- FULL BUCKET SWING/ HALF BUCKET SWING: 50 LBS.
- HEAVY DUTY TODDLER BUCKET SWING: 85 LBS.
- INFANT SWING: 35 LBS.
- TIRE SWING: 125 LBS. TOTAL WEIGHT
- ROPE LADDER: 75 LBS.
- ROCK WALL: 150 LBS.
- CLIMBING RAMP: 150 LBS.
- MONKEY BARS: 175 LBS.
- ALL SLIDES: 150 LBS.

Gorilla recommends that the weight limits for all components must not be exceeded. Failure to adhere to these and other safety guidelines could result in damage to the play set and injury to the users.

PRODUCT REGISTRATION

- PLAYMAKER -

Gorilla Playsets™ manufactures the finest quality products that are designed for outstanding strength and durability. We back our products with unparalleled warranties. In the unlikely event that you need to contact us about covered repairs, we must have a valid Product Registration on file.

3 EASY WAYS TO REGISTER	
OPTION 1	Complete the online registration form at: http://www.gorillaplaysets.com/register
OPTION 2	Fax this completed form to: (678) 880-3300
OPTION 3	Mail this completed form to: Gorilla Playsets 190 Etowah Industrial Court Canton, GA 30114

Where did you buy this product?

Date of Purchase _____

Store _____

Store City _____

Store State _____

Your registration information:

Name: _____ Email: _____

Address: _____

Street

City

State

Zip

Please select your age 18-30 31-40 41-50 51+

How old are your children? 2-3 4-5 6-7 8+

Number of children

How would you rate the quality of this product?

★★★★★ Excellent

★★★★ Above Average

★★★ Average

★★ Below Average

★ Poor

Would you recommend this product to friends & family? Yes No

May we add you to our mailing list? Yes No

May we use your comments on websites or other marketing materials? Yes No

Comments: _____

THIS PAGE INTENTIONALLY LEFT BLANK

IMPORTANT – PLEASE READ

Congratulations! You have just purchase one of the finest residential wooden swing sets available today. As with any wooden product that spends its entire life outside, in varying elements, it is important to know what to expect with your new swing set so that your family can enjoy it for many years.

As your swing set acclimates to its new environment, natural characteristics of the wood can show in the form of checks, or “cracks” in the lumber. In almost all cases this is normal and it will not affect the structural integrity of your play set and is not covered under warranty.

KEEPING YOUR PLAYSET LIKE NEW

MUST DO's

The following owner responsibilities are crucial to the safety, integrity and aesthetic appeal of your swing set and may affect the warranty if not adhered to.

WITHIN 60 DAYS

- Check and tighten Hex Bolts/T-nuts, Carriage Bolts/Lock-nuts, and Lag Screws within the first 60 days and then twice annually – once before each season and then once during the season.

WITHIN 90 DAYS

- Apply a **sealant** or **semi-transparent stain with sealant** within the first 90 days of owning the swing set. Our own Stain/sealant is available online here: <http://www.gorillaplaysets.com/Playground-Sealant-p/10-0003.htm>

Oil based stain or water based stain may be used. Should you choose to use other stain we suggest asking the product covering specialists at any number of specialty paint stores or home improvement centers for a product that would work best for your local environment. ** TIP – while the set is new, take a small board from to the store with you so they can color match the tint of the stain or sealant.

SEASONAL REMINDERS

- If your area experiences regular snowfall, remove your fabric tarp/canopy to avoid stretching, sagging or tearing of the material. Store it inside, folded up, and it will be as good as new when winter is over.
- If your area experiences extremely cold temperatures, remove swing belts and other pliable features to prolong the lifespan of these play activities.

OTHER TIPS

- Spray swing hangers with Pam, Mazola or olive oil to stop squeaking; do not use petroleum based products such as WD-40 or motor oil.
- To repel yellow jackets and wasps, use a cotton ball and dab interior wooden corners underneath the play set deck with a liquid dish soap. Avoid using insecticides.
- To speed up the slide wipe the center of slide with wax paper every 2 - 3 weeks.

For additional safety and maintenance guidelines, please visit our website.



IMPORTANT DOCUMENTS

CUSTOMER MUST READ AND RETAIN

Please go to the following links and read important **SAFETY** information prior to using your new play structure.

<http://www.gorillaplaysets.com/Swing-Set-Safety-s/85.htm>

<https://www.gorillaplaysets.com/Maintenance-s/129.htm>

<http://www.gorillaplaysets.com/manuals.html> (Click on your specific model)

<http://www.gorillaplaysets.com/Warranty-s/82.htm>

NOTE: Your children's safety is our #1 concern. Observing the following statements and warnings reduces the likelihood of serious injury. Please review these safety rules regularly with your children.

WARNING:

Children must NOT use this play set until it has been completely assembled and inspected by an adult to ensure it has been properly installed.

Gorilla Playsets
190 Etowah Industrial Court
Canton, GA. 30114



Model: 2401

(BOXES: 2401-1, 2401-2 &
Slide Box)

REV: 3.2.2018

TABLE OF CONTENTS

Safety Guidelines.....	Page 3-6
Leveling Fort, General Information and Definitions.....	Pages 6-8
How to Install T-nuts, Board Identification, Predrill Lag Screw Directions and Swing Beam Loading.....	Pages 9-13
Site Plan, Required Tool List and Kit Contents.....	Pages 14-15
Hardware, Lumber and Accessory Checklists.....	Pages 16-27
Corner Post Layout and Adding T-Nuts to Corner Posts.....	Steps 1-2
Framing Fort.....	Steps 3-10
Attaching Deck Boards/Deck Spacers and Deck Stringer.....	Steps 11-12
Attaching Front Face Board and Panel Board at rear.....	Steps 13-14
Angle Support Installation.....	Step 15
Swing Beam Plate/Mount, Iron Ductiles and Trapeze Arm Installation.....	Steps 16-18
Building and Mounting Rockwall/Ladder Combination.....	Steps 19-24
Swing Beam Assembly.....	Steps 25-29
Bottom Panel Boards and Panel Slat Installation.....	Steps 30-31
Center Posts, Framing Tarp, Front Wall and Windows.....	Steps 32-33
Sun/Sunburst, Tarp and Roof Peak Support Installation.....	Steps 34-36
Installing the Slide.....	Step 37
Climbing Rope, Tic Tac Toe and Steering Wheel.....	Steps 38-41
Flag Kits.....	Step 42
Name Plate, Accessories.....	Steps 43-47
Ground Stakes, Sandbox Seats and Safety Handles.....	Steps 48-50

**PLEASE READ OWNER'S MANUAL CAREFULLY
BEFORE STARTING ASSEMBLY!**

Safety and Maintenance Tips for Your New Play Set:

NOTE: Your children's safety is our #1 concern. Observing the following statements and warnings reduces the likelihood of serious or fatal injury. Please review these safety rules regularly with your children.

- This play set is designed for the use of 4 occupants who have a combined weight not exceeding 800 pounds on the elevated floor, 3 occupants who have a combined weight of 425 pounds on the swing area, for a total Unit capacity of 7 occupants who have a combined weight of 1225. (This weight does not include any picnic table area(s).)
- On-site adult supervision is required.
- Teach children not to walk close to, in front of, behind, or between moving swings or other moving playground equipment.
- Teach children to sit in and never stand on swings
- Teach children not to twist the chains and ropes and not to loop them over the swing beam, since this may reduce the strength of the chain or rope.
- Teach children not to jump from swings or other playground equipment in motion.
- Teach children not to push empty seats. The seat may hit them and cause serious injury.
- Teach children to sit in the center of the swings with their full weight on the seats.
- Teach children not to use the equipment in a manner other than intended.
- Teach children to always go down slides feet first. Never slide headfirst.
- Teach children to look before they slide to make sure no one is at the bottom.
- Teach children to never run up a slide, as this increases their chances of falling.
- The parents should have the children dress appropriately with well-fitting shoes. Loose clothing such as scarves and ponchos should not be worn. Always take off, tie up or tuck in cords and drawstrings on children's clothing. These things can get caught on playground equipment and strangle a child.
- Teach children not to climb when the equipment is wet.
- Teach children to never jump from a fort deck. They should always use the ladder, ramp or slide.
- Teach children to never crawl or walk across the top of monkey bars or swing beam.
- Teach children to never crawl on top of a fort roof or on the outside of a tube slide.
- Verify that any suspended climbing ropes, chains, or cables are secured at both ends and that they cannot be looped around an adult hand.
- Teach children not to attach items to the playground equipment that are not specifically designed for use with the equipment, such as, but not limited to, jump ropes, clothesline, pet leashes, cables and chain as they may cause a strangulation hazard.
- Teach children to never wrap their legs around swing chain.
- Teach children to never slide down the swing chain.
- Teach children to remove their bike or other sports helmet before playing on the playground equipment.
- Teach children to NEVER look at the sun or other bright light through any accessory such as but not limited to a telescope, periscope or binoculars.

WARNING: Children must NOT use this play set until it has been completely assembled and inspected by an adult to insure it has been properly installed and the swing beam legs are anchored.

Safety and Maintenance Tips for Your New Play Set: (continued)

Playgrounds should be inspected on a regular basis. If any of the following conditions are noted, they should be removed, corrected, or repaired immediately to prevent injuries.

- Hardware that is loose, worn or that has protrusions or projections.
- Exposed equipment footings.
- Scattered debris, litter, rocks, or tree roots.
- Splinters, large cracks, and decayed wood components.
- Deterioration and corrosion on structural components, which connect to the ground.
- Missing or damaged equipment components, such as handholds, guardrails, swing seats.
- Check all nuts and bolts twice monthly during the usage season and tighten as required. (But not so tight that you crack the wood) We recommend you check the swing beam and hardware often due to wood expansion and contraction. It is particularly important that this procedure be followed at the beginning of each season.
- Remove plastic swing seats and take indoors or do not use when the temperature drops below 32°F. Reinstall swings and other swing equipment at the beginning of the usage season.
- Oil all metallic moving parts monthly during the usage period.
- Check all coverings for bolts and sharp edges twice monthly during usage season to be certain they are in place. Replace when necessary. It is especially important to do this at the beginning of each new season.
- Check swing seats, ropes, cables and chains monthly during usage season for evidence of deterioration. Replacement should be made of any swing seat that has developed cracks in the plastic seats. Ropes, cables and chains should be removed and replaced if excessive wear is found. Contact us for warranted replacement parts.
- Swing chains, rings, ropes, etcetera should always be fastened to a rotating swing hanger. NEVER attach a chain, ring, rope, etcetera to a stationary hanger such as but not limited to an eye bolt. Severe wear could occur leading to an injury.
- For rusted areas on metallic members such as monkey bars, hand supports brackets, etc.; sand and repaint, using a non lead-based paint meeting the requirements of Title 16 C.F.R. Part 1303. These requirements are available at: <http://www.cpsc.gov/>
- Inspect wood parts monthly. The grain of the wood sometimes will lift in the dry season causing splinters to appear. Light sanding may be necessary to maintain a safe playing environment. If you are treating your play set with stain regularly, it will help prevent severe checking/splitting and other weather damage.
- Once or twice a year, depending on your climate conditions, you must apply some type of protection (sealant) to the wood of your unit. Prior to the application of sealant, lightly sand any “rough” spots on your set. Please note this is a requirement of your warranty.
- Creating and maintaining the play set on a level location is very important. As your children play, your play set will slowly dig its way into the soil, and it is very important that it settles evenly. Make sure the play set is level and true once each year or at the beginning of each play season.
- Twice a month during the usage season rake the playground protective surfacing materials to prevent compaction and maintain appropriate depths. Replace the protective surfacing materials as required.
- Disposal Instructions: When the play set is no longer desired, it should be disassembled and disposed of in such away that no unreasonable hazards will exist at the time the play set is discarded.

Play Set Surfacing Recommendations:

Below are some of the recommendations that the U.S. Consumer Product Safety Commission (CPSC) offers from its Handbook for Public Playground Safety. The guide can be downloaded in full at <https://www.cpsc.gov/s3fs-public/325.pdf>

1. Protective Surfacing - Since almost 60% of all injuries are caused by falls to the ground, protective surfacing under and around all playground equipment is the most critical safety factor on playgrounds.

Certain manufactured synthetic surfaces also are acceptable; however, test data on shock absorbing performance should be requested from the manufacturer.

Asphalt and concrete are unacceptable. They do not have any shock absorbing properties. Similarly, grass and turf should not be used. Their ability to absorb shock during a fall can be reduced considerably through wear and environmental conditions.

Certain loose-fill surfacing materials are acceptable. Surfacing materials are acceptable, such as the types and depths shown in the table.

Fall Heights and Materials

Type Of Material	6 in. depth	9 in. depth	12 in. depth
Double-Shredded bark mulch	6' Fall Height	10' Fall Height	11' Fall Height
Wood Chips	6' Fall Height	7' Fall Height	12' Fall Height
Fine Sand	5' Fall Height	5' Fall Height	9' Fall Height
Shredded Tires*	10-12' Fall Height	N/A	N/A
Fine Gravel	6' Fall Height	7' Fall Height	10' Fall Height

*This data is from tests conducted by independent testing laboratories on a 6-inch depth of uncompressed shredded tire samples produced by four manufacturers. The tests reported critical heights, which varied from 10 feet to greater than 12 feet. It is recommended that persons seeking to install shredded tires as a protective surface request test data from the supplier showing the critical height of the material when it was tested in accordance with ASTM F1292.

It should be recognized that all injuries due to falls cannot be prevented no matter what surfacing material is used.

2. Fall Zones - A fall zone, covered with a protective surfacing material, is essential under and around equipment where a child might fall. This area should be free of other equipment and obstacles onto which a child might fall. Stationary climbing equipment and slides should have a fall zone extending a Minimum of 6' in all directions from the perimeter of the equipment.

Swings should have a fall zone extending a minimum of 6' from the outer edge of the support structure on each side. The fall zone in front and back of the swing should extend out a minimum distance of twice the height of the swing as measured from the ground to the top of the swing support structure.

LEVELING YOUR FORT DURING ASSEMBLY

- Complete the steps which will be the basic frame of the fort. {i.e. four corner posts with base (sand box boards) and deck supports}
- Position in the most level area chosen for the play set, keeping in mind the location and size of the swing beam, ladder, slides, etc. that extend off the fort.
- Once the frame is in the final position, check for vertical and horizontal levelness to determine which side(s) will need to be dug into the ground to level the play set.
- With a shovel, score the ground around the outside edges of the sandbox boards on the 'high' side of the fort. This is the area that will be dug in. Make sure to score deep enough; the scored lines will be your digging template.
- Push the frame off and away from the scored area, far enough to dig and remove dirt to reach the appropriate depth.
- Dig a channel along the scored line(s) for the base of the fort (corner post and sandbox boards) to rest into. Dig the channel(s) to the same level depth. The bottom of the channel(s) should be level to each other so your frame doesn't teeter or rock because the channel(s) are uneven.
- Once you have removed enough grass and dirt, slide/push the frame into the channel(s). Place a level on the vertical and horizontal boards of the frame to determine if enough soil, or too much, was removed.
- Repeat this process until the basic frame is plumb and level and in its final position before completing the rest of the assembly.
- Measure to make sure fort is square.

Important: if you require a channel depth of more than 6", then we recommend you have your play set area professionally graded before completing assembly.

Example Play area:

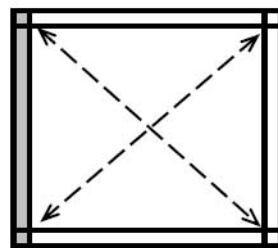

The diagonal measurements should be the same from corner post to corner post. If not, adjust corner posts so that the distance is equal.

■ = Area to be scored and channeled for levelness

General Info to Review Before Installation

- Depending on your experience, assembly of the playset can take as little as 6 hours up to 24 hours, depending on size, after inventory of parts; therefore, we recommend you set aside a full two days for assembly.
- Identify all of the parts for your play set. Empty each box and lay out boards so you can see each part. Your instruction book will have detailed drawings that will make it easy for you to recognize individual parts. Keep all hardware and metal parts separate from wooden pieces.
- After everything is laid out, check carefully to ensure all parts are present. Make sure there are no broken boards.
- Find an area to sort your hardware. It is best to open the hardware on a solid surface so that you do not lose any pieces in the grass. This will save time and familiarize you with all the different pieces in the hardware bag.
- Important note: Wood has some natural defects such as knots, surface cracks, etc... We reject parts that are structurally defective. We use a high quality lumber in our structures; however, you should inspect each part for splinters or rough spots and sand them smooth to prevent injury.
- After familiarizing yourself with all of the components, read all instructions thoroughly. Reading instructions after you have studied the parts will help you understand the installation process, and help to eliminate unnecessary mistakes.
- Pay close attention to the diameter and length of each bolt and screw.
- Never tighten hardware completely at first. It helps to have some adjustment for bolt alignment while you are attaching parts together. After everything is square, tighten each joint.
- After the main unit is assembled it is critical that the floor is level and square. If the main frame is not level, the walls and floor will be out of square.
- After you complete installation, make sure every bolt, screw, and nut is tight, and every board is secure. Wood will expand and contract with the seasons.
- Place the set on level ground, not less than 6 feet from any structure or obstruction such as a fence, garage, house, overhanging branches, laundry lines, or electrical wires.

This page is a list of definitions and explanations used throughout our instructions to aid you in the assembly of your play set.

Offset Holes- Throughout the installation procedures we will refer to parts with offset holes. This refers to the orientation of the holes on the board. An offset hole is one that is closer to one side than it is the other or in other words, it is not centered on the board. In the procedures you will be instructed to attach the boards with the holes offset up or with the holes offset down. This refers to which side of the board the hole/holes should be closer to. Offset holes up= hole/holes will be closer to the top of the board. Offset holes down= hole/holes will be closer to the bottom of the board. Note: some parts do not have offset holes, but instead the holes are on center. Therefore there will not be any reference on how to offset these parts.

EXAMPLE OF OFFSET HOLES UP



EXAMPLE OF OFFSET HOLES DOWN



Counter-sunk holes - Many of the parts that will be used have counter-sunk holes. A counter-sunk hole is one that surrounds one side of a through hole, but does not extend through the wood it's self. When using a counter-sunk hole the bolt will be inserted through the through hole and either the head of the bolt and washer or nut and washer will occupy the counter sunk hole.

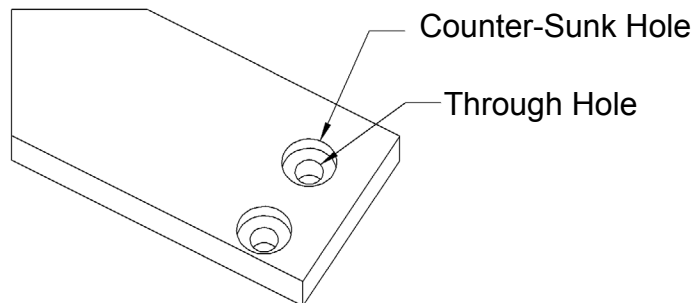

Lag Screws- Lag screws are used in the construction of our play sets to enhance the structural integrity of the unit. There will not be predrilled holes in the post for lag screw installation. Lag screws are self-tapping, though if you are using a manual socket wrench it may be advantageous to pre-drill a hole first. Instructions for this are provided on a separate page in the front of the manual. Be sure to tighten the lags completely when driving them in by hand. Power tools such as a heavy duty impact driver or large power drill should have enough torque to drive in the lag screws, but make sure not to over tighten as this can cause the threads to “strip out” in the post.

Common Installation Practice Installing T-nuts

When installing T-nuts into the wood, use a smooth faced hammer to set the face of the T-nut flush into the wood.

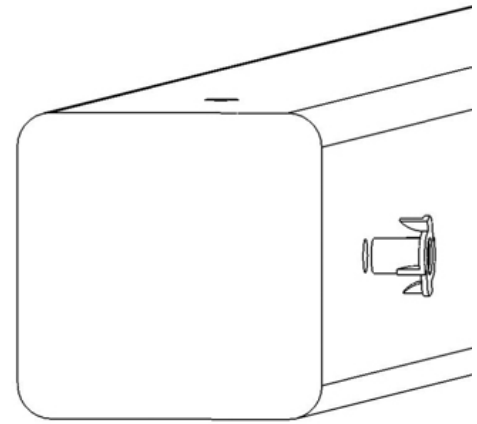
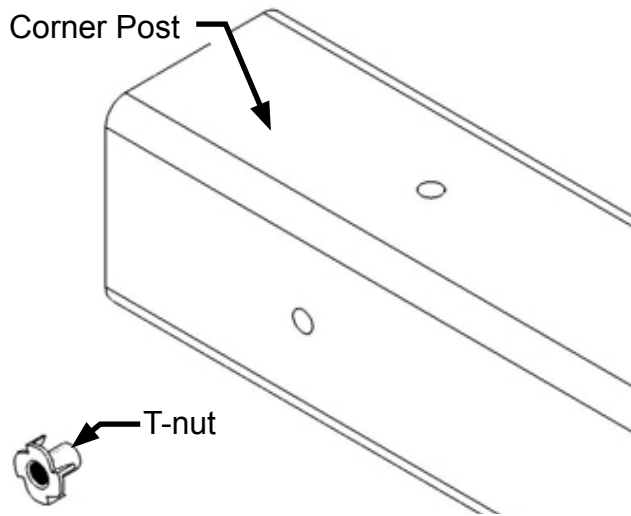

Insert the barrel of the T-nut into the predrilled hole. Using a smooth faced hammer, drive the T-nut until the face of the T-nut is flush to the wood.



This picture shows the T-nut inserted and installed flush to the wood.

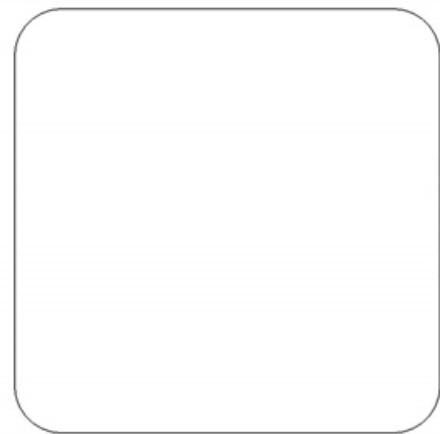

This picture shows an end view of the T-nut installed flush to the wood.

WARNING: DO NOT EMBED THE TOP OF THE T-NUT INTO THE FACE OF THE WOOD



Cross Section end view, you are looking at an X-ray view of the post and T-nut. The barrel of the T-nut is in the corner post the line is the face of the wood.

HOW A T-NUT WORKS

THE FIRST STEP IN OUR ASSEMBLY INSTRUCTIONS IS TO INSERT T-NUTS INTO THE CORNER POSTS. A T-NUT IS A FASTENER WHICH IS THREADED ON THE INSIDE AND IT FUNCTIONS JUST LIKE A STANDARD HEX NUT. YOU INSERT THE T-NUTS INTO THE PREDRILLED HOLES IN THE CORNER POSTS.

THE T-NUT HAS A BARREL SHAPED END WHICH GOES INTO THE HOLE IN THE CORNER POST. THE T-NUT ALSO HAS AN FLANGE SHAPED END WITH TEETH. THE TEETH PENETRATE INTO THE CORNER POST WOOD TO PREVENT THE T-NUT FROM SPINNING WHEN YOU TIGHTEN THE HEX HEAD BOLT.

SHOWN BELOW YOU WILL SEE THE T-NUT IS HAMMERED INTO THE CORNER POST ON THE BACK SIDE. THE BOARD IS BEING ATTACHED ON THE FRONT SIDE OF THE CORNER POST.

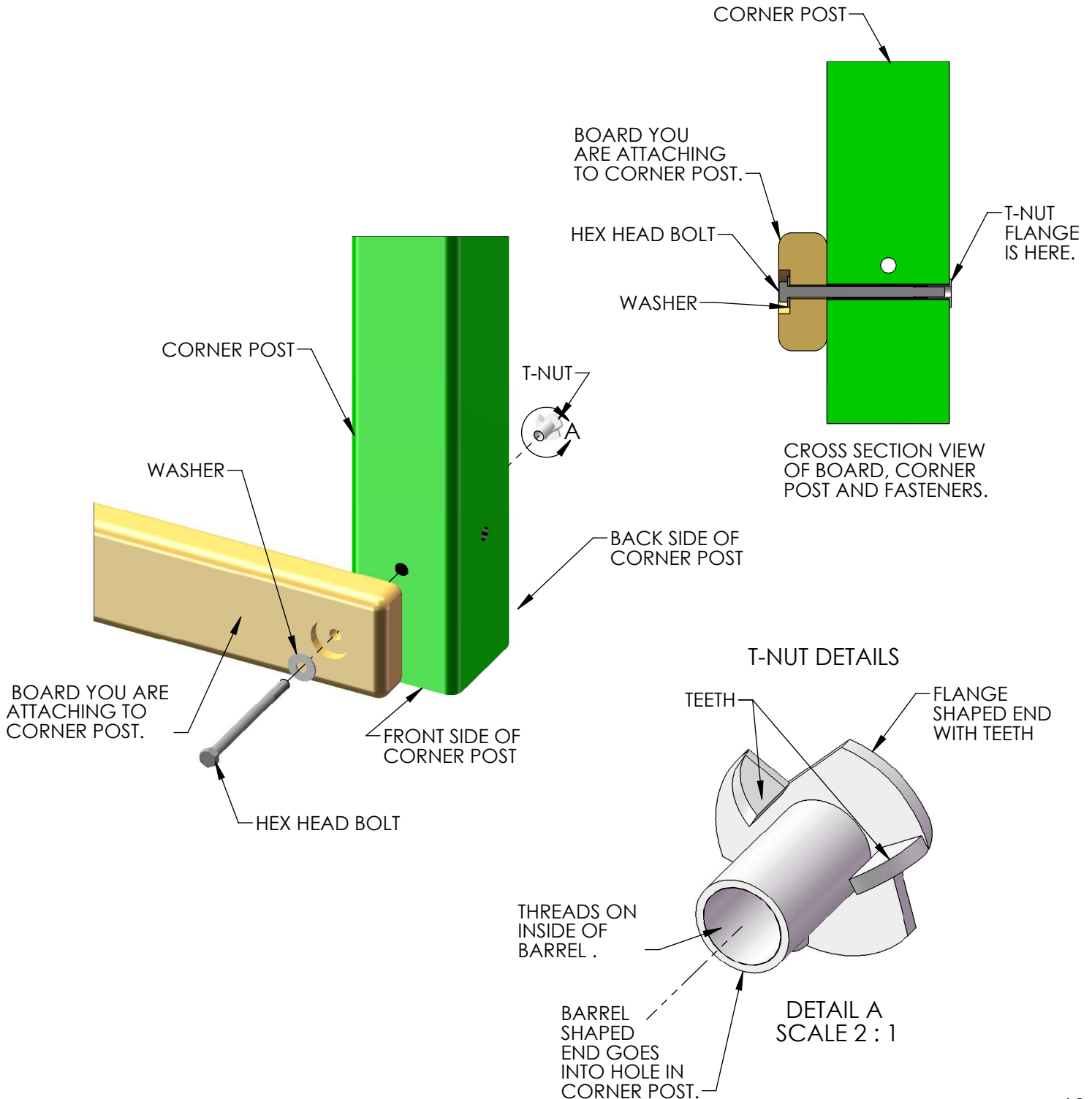

BOARD IDENTIFICATION

1. On the end of each board there should be a small white tag that is stapled or stuck into place. Remove the staples and/or tag after the board is installed.
2. This white identification tag displays the thickness, width, length and an abbreviated description of the part.

Example: a tag reads "2-4-3600-BPB"

- The 2 is the thickness of the board. "Nominal Lumber" at a home center will measure 1-1/2" for the thickness. We "remill" that lumber to 1-3/8" thick.
- The 4 is the width of the board. "Nominal Lumber" at a home center will measure 3-1/2" for the width. We "remill" that lumber to 3-3/8" wide.
Note: sometimes the width will be smaller than 3-3/8" because:
A) We need the width of the part to fit into a certain area of the play set.
B) We need the designation to be simple.
- The 3600 is the length of the board. It means the board is 36 inches long. If the code were 3625 then the board is 36-1/4" in length.
- The "BPB" abbreviation stands for "Bottom Panel Board". The wood part bill of materials in the instructions has a description which will match the abbreviation closely.
- In the event that there is no tag on a wood part measure the part then:
A) Use the measurements and compare them to the wood list at the front of the instructions to identify it.
B) Look at the holes on the wood part and compare them to the pictures in the wood list.
C) Look to see if the holes are centered or if they are offset up or offset down.
This should help you identify any parts that have missing tags. In the event that you cannot identify a board please email us for assistance.



PRE-DRILL LAG SCREW DIRECTIONS

Pre-drilling holes for lag screws will make it easier to drive the screws in by hand. "Jobber" length drill bits are available in sizes that are longer than standard drill bits and those are ideal for the job. When using the drill bit you will have to "spot" drill the post and then remove the board you are attaching to finish drilling the hole.

Pay attention to the *DIAMETER* of the lag screw you are installing. Your playset may come with two different diameter lag screws. Each diameter will require a different size drill bit. When installing lag screws **DO NOT OVERTIGHTEN.**

LAG SCREW DIAMETER	DRILL BIT SIZE
5/16" DIAMETER	9/64"
3/8" DIAMETER	11/64"

Example: 3/8" diameter x 3-1/2" lag screw

This would be like the 2 x 4 board installation shown below. Place the board into position. Spot Drill through the holes in the 2 x 4 board into the corner posts with an 11/64" drill bit. Remove the 2 x 4 board. Continue to drill the holes to a total depth of 2-5/16" as shown at the right. Install the 2 x 4 board.

Example 5/16" diameter x 3-1/2" lag screw

This would be like the 2 x 4 board installation shown below. Place the board into position. Spot Drill through the holes in the 2 x 4 board into the corner posts with an 9/64" drill bit. Remove the 2 x 4 board. Continue to drill the holes to a total depth of 2-5/16" as shown at the right. Install the 2 x 4 board.

Example 3/8" diameter x 5" lag screw

This would be like the 4 x 4 board installation shown below. Place the board into position. Spot drill through the holes in the 4 x 4 board into the corner posts with an 11/64" drill bit. Remove the 4 x 4 board. Continue to drill the holes to a total depth of 2-13/16" as shown at the right. Install the 4 x 4 board.

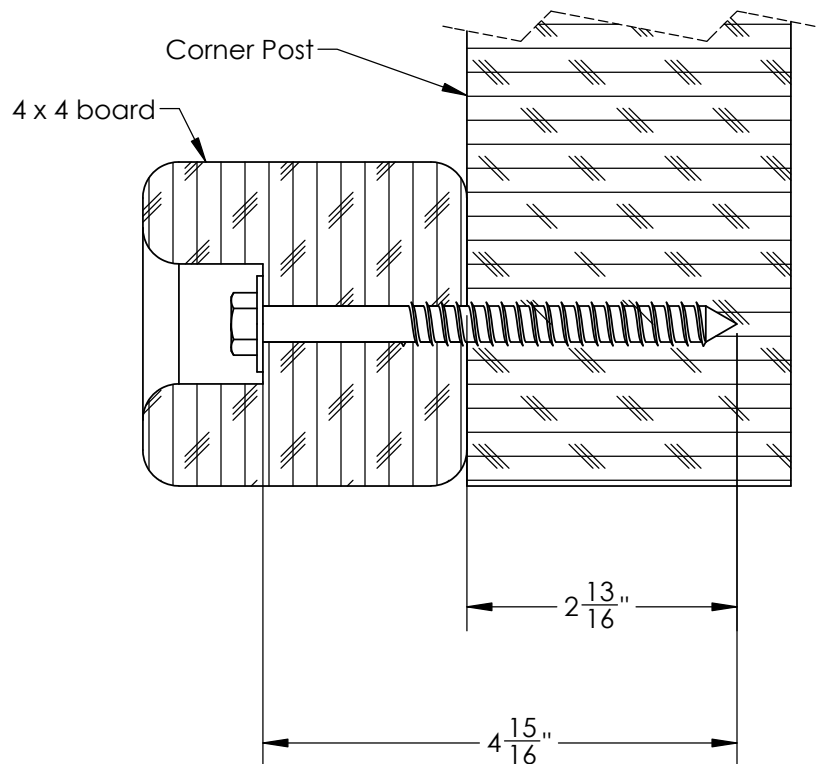
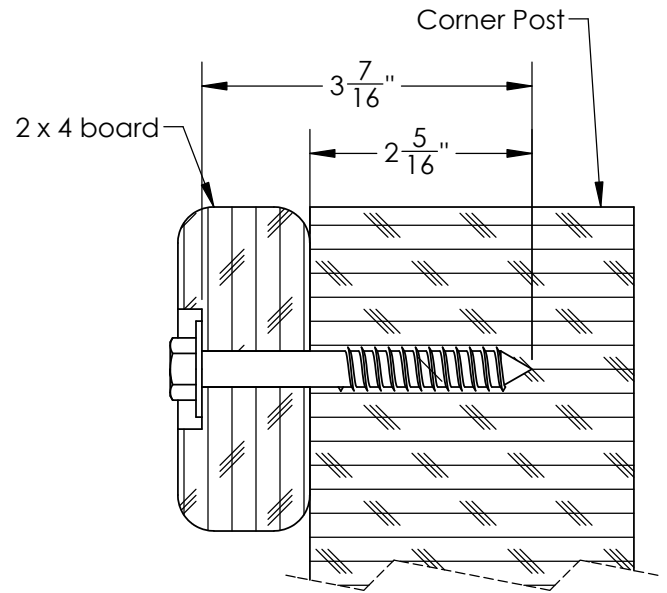

SWING BEAM LOADING

Weight Limits for Accessories:

The weight limit for a Swing Belt is 225 lbs. (Although 150lbs is the maximum recommended swinging weight capacity for the swing position.)

The weight limit for a Trapeze Bar is 125 lbs.

Maximum Allowable swinging weight for a three position swing:

- 1) The maximum allowable swinging weight at each Swing Belt position is 150 lbs.
- 2) The maximum allowable swinging weight at the Trapeze position is 125 lbs.
- 3) The MAXIMUM SWING BEAM LOAD IS 425 lbs.

MAXIMUM SWING BEAM LOAD IS 425 LBS.

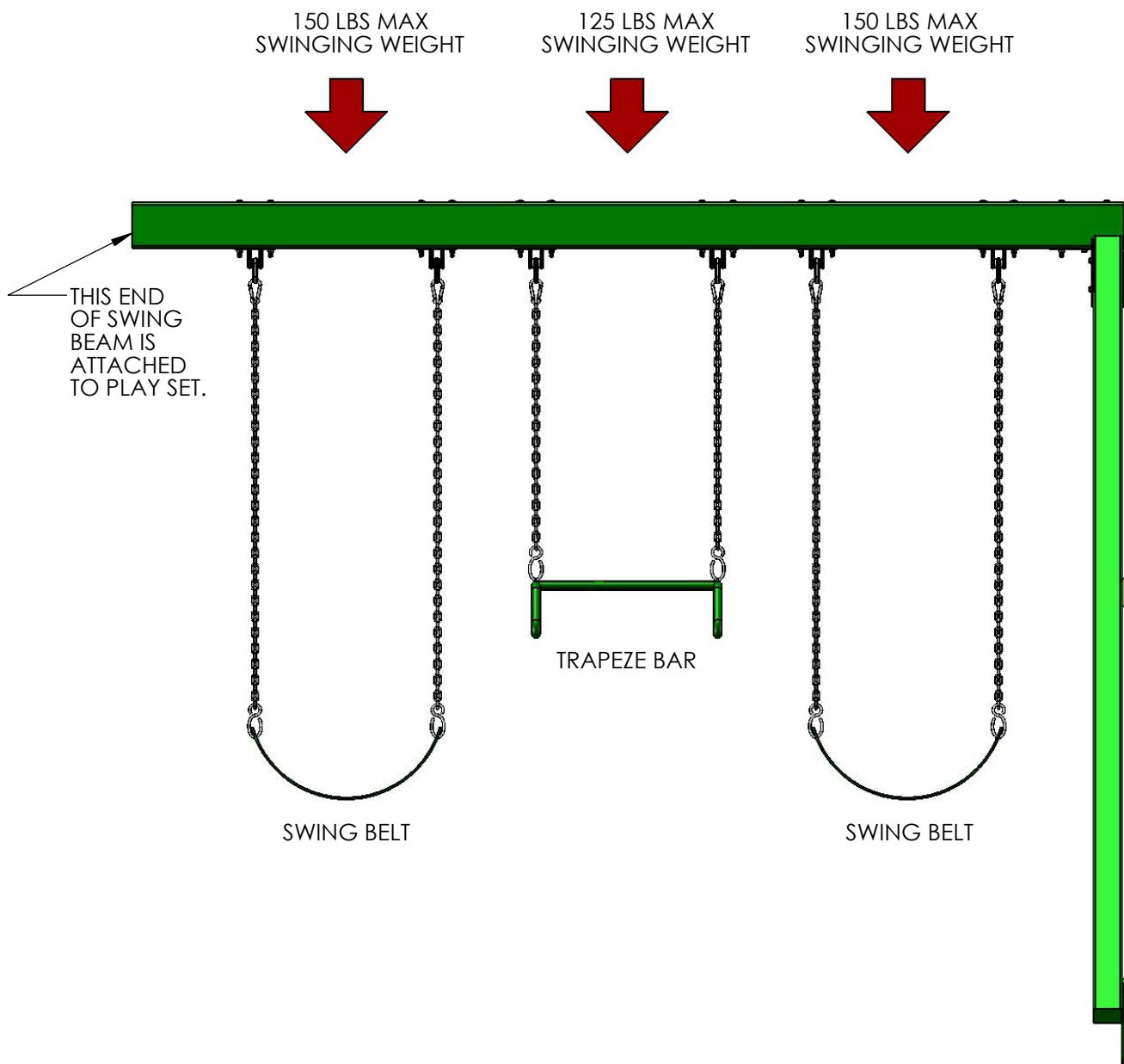

Please familiarize yourself with the manual, parts/components and general construction process of your new playset before getting started.

SITE PLAN:

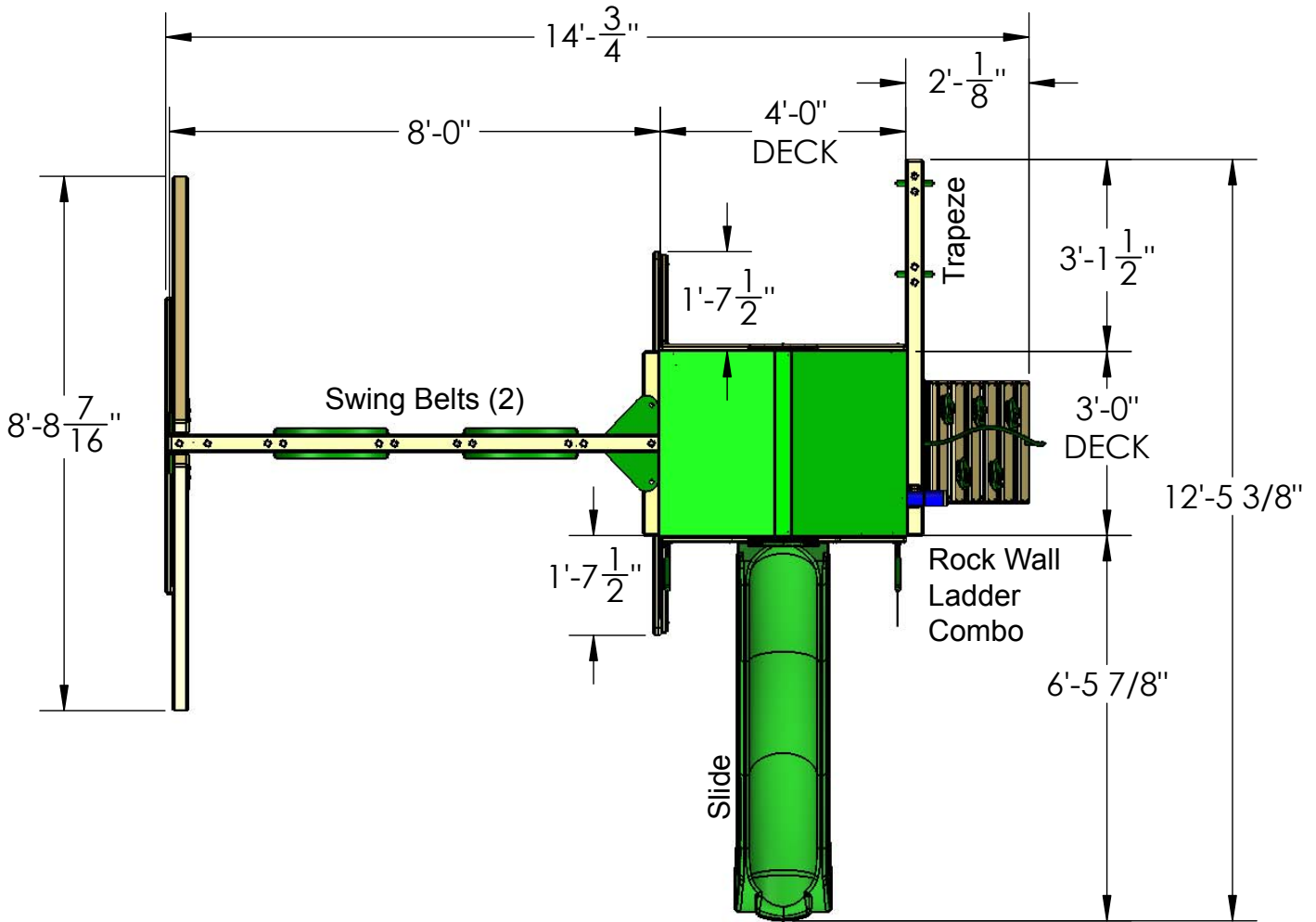

Playset height: 9 feet - 10 -3/4 inches
Deck height: 4 feet
Swing Beam Height: 7 feet - 2-1/2 inches

Approximate assembly time: 6-8 hours

(6) foot unobstructed safety perimeter around playset recommended

REQUIRED TOOL LIST:

- ___ Standard or Cordless Drill w/ Phillips Bit (#2 square bit provided)
- ___ Drill Bits 1/8", 3/8", 9/64", 11/64"
- ___ 1/2" Wrench and Socket
- ___ 1/2" Deep Well Socket
- ___ 9/16" Deep Well Socket
- ___ 9/16" Wrench and Socket
- ___ Level
- ___ Tape Measure
- ___ Extension Cord (if using standard drill)
- ___ Hammer
- ___ Pencil
- ___ Locking Pliers (Vise Grips)
- ___ Shovel

KIT CONTENTS

Swings, Slides, Accessories:

- ___ (Qty) Description
- ___ (2) Swingbelt w/ Chains
- ___ (1) Trapeze w/ Chains
- ___ (1) Wave Slide
- ___ (5) Rock Wall Grip (assorted colors)
- ___ (1) Looney Telescope
- ___ (1) Looney Periscope
- ___ (1) Crown
- ___ (1) Steering Wheel
- ___ (2) Safety Handle
- ___ (1) Tic Tac Toe
- ___ (2) Flag
- ___ (1) 05-0014 Tarp
- ___ (1) Chalkboard
- ___ (3 pair) Ground Stakes
- ___ (2) Plastic Dormer Window 07-0029-G

Fort Hardware:

see following pages

Swing Beam Hardware:

see following pages

Wood Components:

see following pages

#14 X 1-1/4"
PAN HEAD
SCREW
QTY: 3



#8 X 1"
WOOD SCREW
QTY: 8



#8 X 1-1/4"
WOOD SCREW
QTY: 10



#8 X 1-1/2"
WOOD SCREW
QTY: 26



#8 X 1-3/4"
WOOD SCREW
QTY: 4



#8 X 2"
WOOD SCREW
QTY: 138



#8 X 2-1/2"
WOOD SCREW
QTY: 44



#8 X 3"
WOOD SCREW
QTY: 14

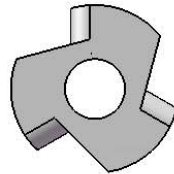

5/16" TEE NUT
QTY: 42



3/8" LOCK NUT
QTY: 21

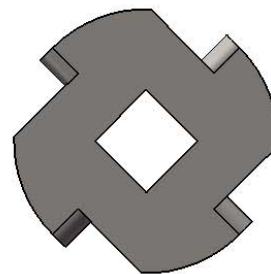

TORQUE WASHER
QTY: 19

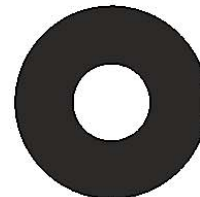

3/8" WASHER
QTY: 33

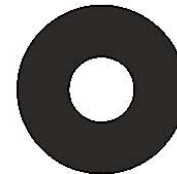

5/16" WASHER
QTY: 54



1/4" WASHER
QTY: 10

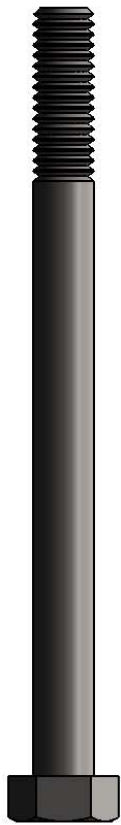

5/16 X 4"
HEX BOLT
QTY: 34

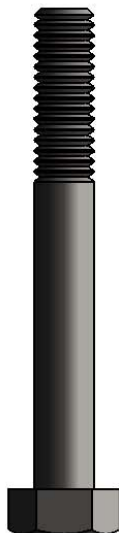

5/16 X 2-1/2"
HEX BOLT
QTY: 4



5/16 X 1-1/2"
HEX BOLT
QTY: 4

11-0077
2401 HARDWARE
PAGE 1 OF 2
9/16/2015 JH

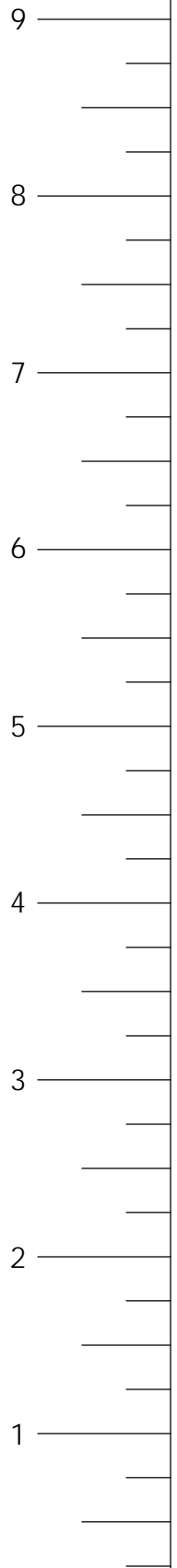

USE THE RULER TO THE RIGHT TO MEASURE YOUR BOLTS AND SCREWS. PICTURE VIEWS SHOWN ABOVE ARE 1:1 SCALE AND CAN BE USED TO MATCH BOLT AND SCREW SIZES.

11-0077
 2401 HARDWARE
 PAGE 2 OF 2
 9/16/2015 JH

3/8 x 3-1/2"
 LAG SCREW
 QTY: 4

3/8 x 2-1/2"
 LAG SCREW
 QTY: 8

5/16 x 3-1/2"
 LAG SCREW
 QTY: 12

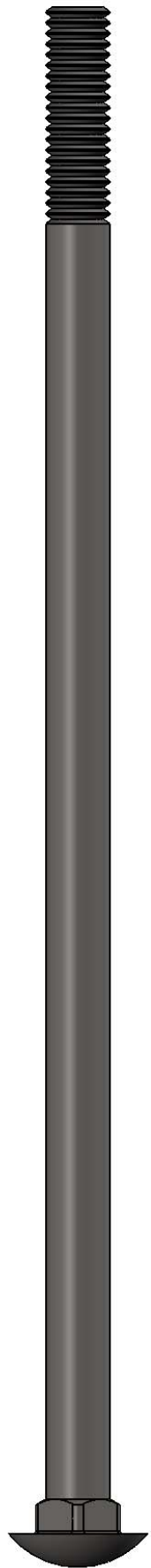

3/8 x 9"
 CARRIAGE BOLT
 QTY: 1

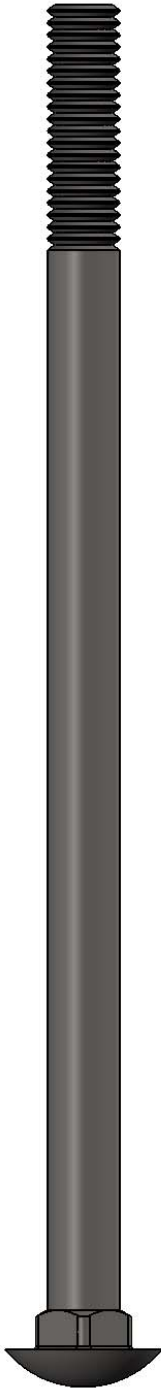

3/8 x 7"
 CARRIAGE BOLT
 QTY: 10

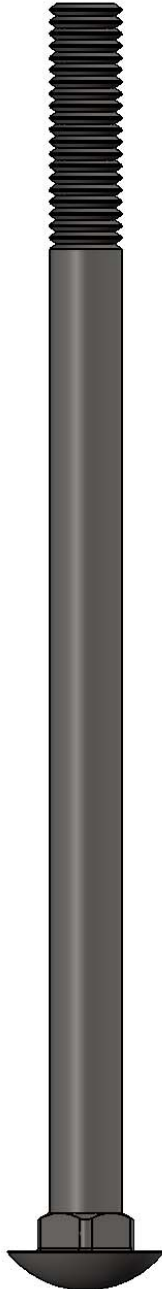

3/8 x 6-1/2"
 CARRIAGE BOLT
 QTY: 4

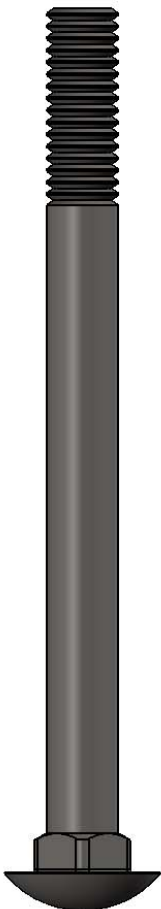

3/8 x 4-1/2"
 CARRIAGE BOLT
 QTY: 4

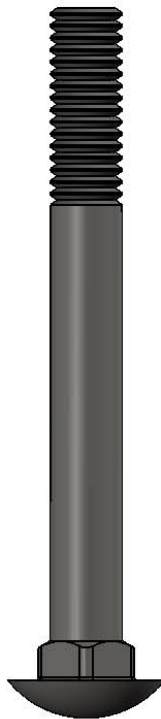

3/8 x 3-1/2"
 CARRIAGE BOLT
 QTY: 2

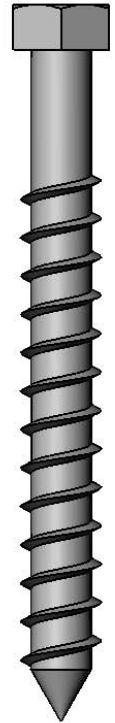
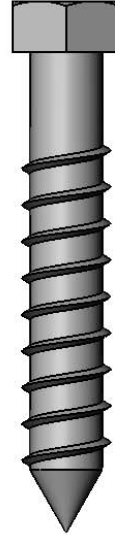
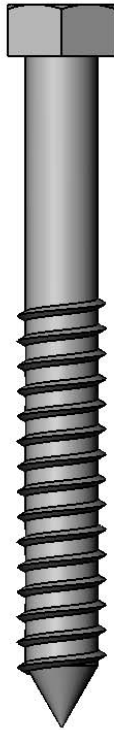

#2 SQUARE
 DRIVE TIP
 QTY: 1



PLASTIC
 BOLT CAP
 QTY: 21

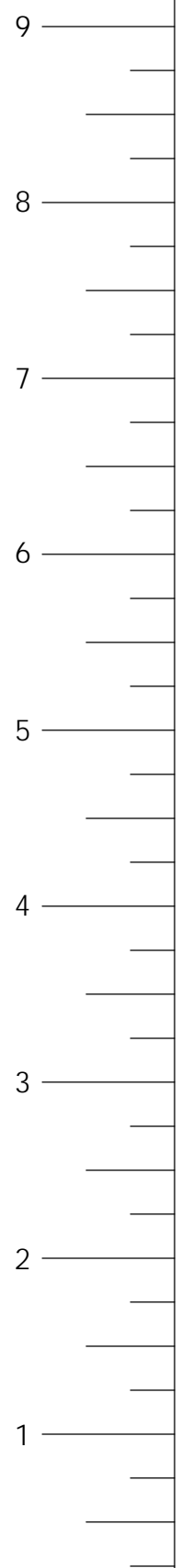

USE THE RULER TO THE RIGHT TO MEASURE YOUR BOLTS AND SCREWS. PICTURE VIEWS SHOWN ABOVE ARE 1:1 SCALE AND CAN BE USED TO MATCH BOLT AND SCREW SIZES.

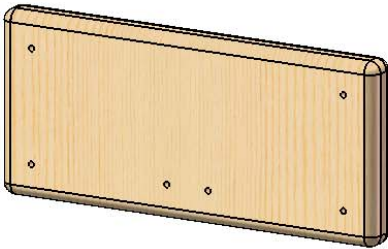
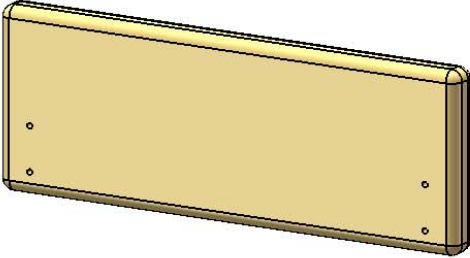
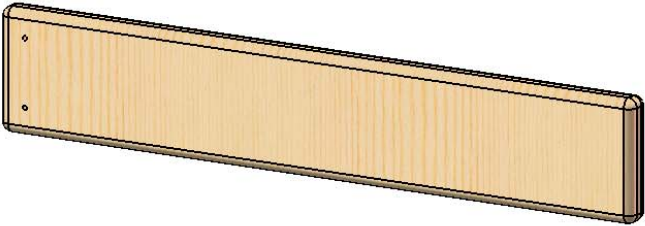
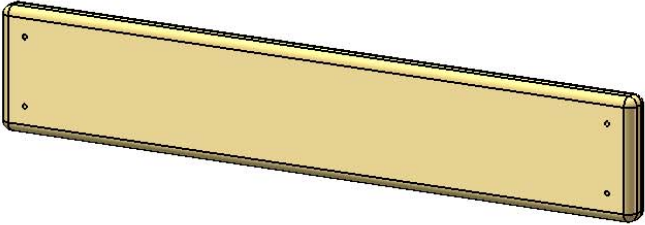
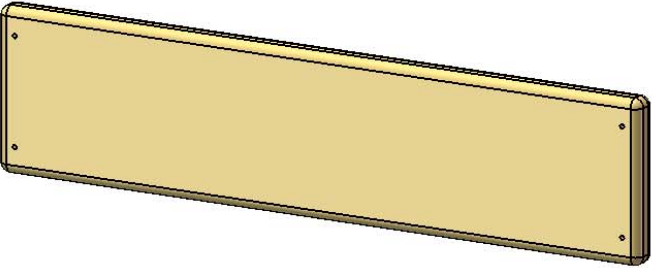
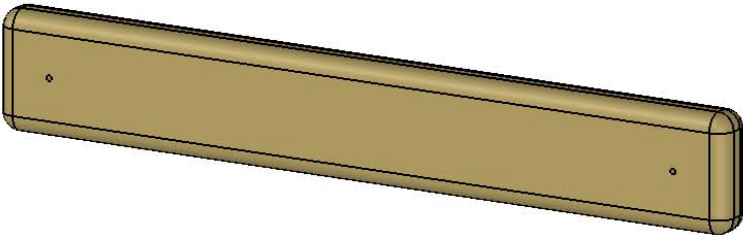
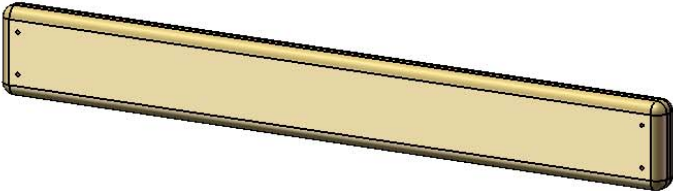
PICTURE	DESCRIPTION	QTY.
	<p>1 X 4 X 9" CONNECTOR BOARD</p> <p>1-4-1900-CB</p>	<p>1</p>
	<p>1 X 4 X 11" WALL PANEL BOARD 3</p> <p>1-4-1100-WPB3</p>	<p>2</p>
	<p>1 X 4 X 19" CENTER WALL PANEL BOARD</p> <p>1-4-1900-CWPB</p>	<p>1</p>
	<p>1 X 4 X 19" WALL PANEL BOARD 1</p> <p>1-4-1900-WPB1</p>	<p>2</p>
	<p>1 X 5 X 19-1/4" WALL PANEL BOARD 2</p> <p>1-5-1925-WPB2</p>	<p>2</p>
	<p>5/4 X 3 X 17-1/2" TIC TAC TOE MOUNT</p> <p>125-3-1750-TTM</p>	<p>2</p>
	<p>5/4 X 3 X 23-7/8" ROCK WALL TOP CAP</p> <p>125-3-2388-RWTC</p>	<p>1</p>

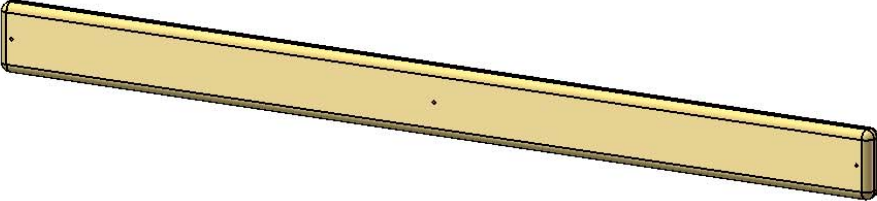
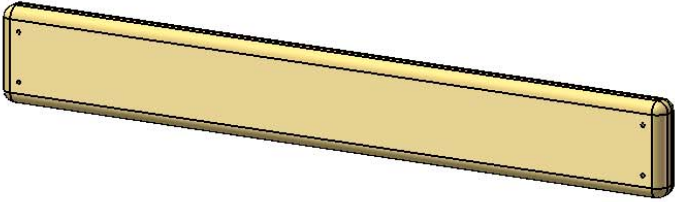
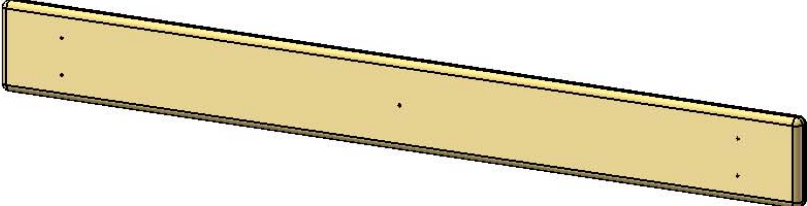
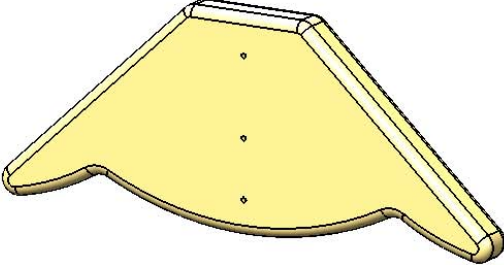
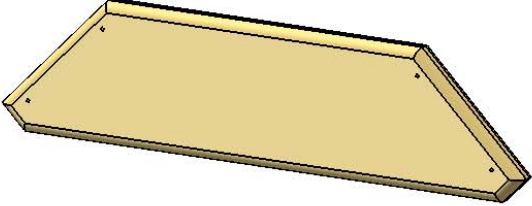
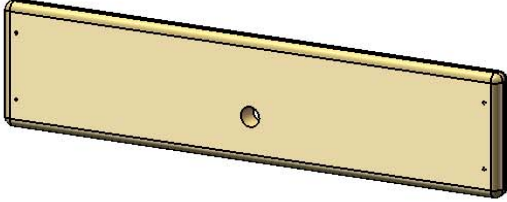
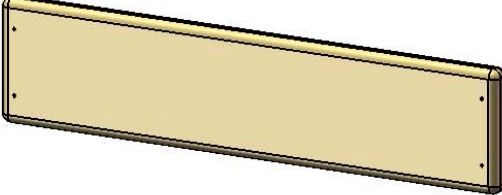
PICTURE	DESCRIPTION	QTY.
	<p>5/4 X 3 X 41-7/8" DECK SPACER</p> <p>125-3-4188-DS</p>	<p>2</p>
	<p>5/4 X 4 X 23-7/8" ROCK WALL TOP</p> <p>125-4-2388-RWT</p>	<p>1</p>
	<p>5/4 X 5 X 48" DECK BOARD</p> <p>125-5-4800-DB</p>	<p>6</p>
	<p>5/4 X 6 X 13-3/16" ROOF PEAK SUPPORT</p> <p>125-6-1323-RPS</p>	<p>2</p>
	<p>5/4 X 6 X 22" SANDBOX SEAT</p> <p>125-6-2200-SS</p>	<p>2</p>
	<p>5/4 X 6 X 23-7/8" ROCK WALL BOARD BOTTOM</p> <p>125-6-2388-RWBB</p>	<p>1</p>
	<p>5/4 X 6 X 23-7/8" ROCK WALL BOARD</p> <p>125-6-2388-RWB</p>	<p>5</p>

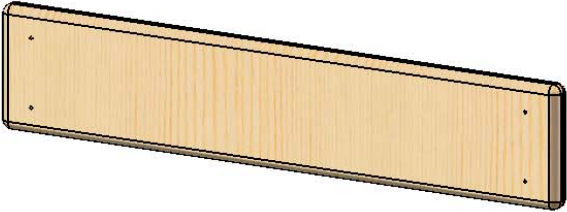
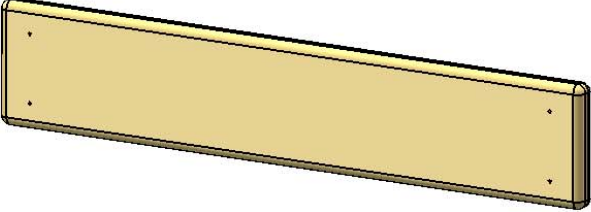
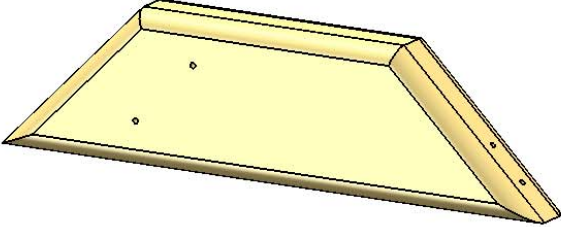
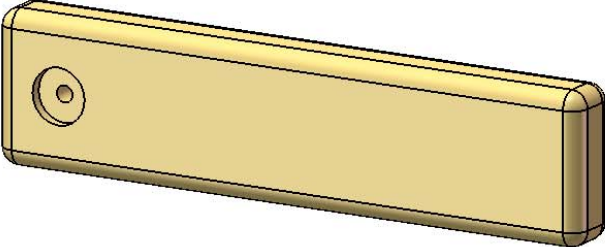
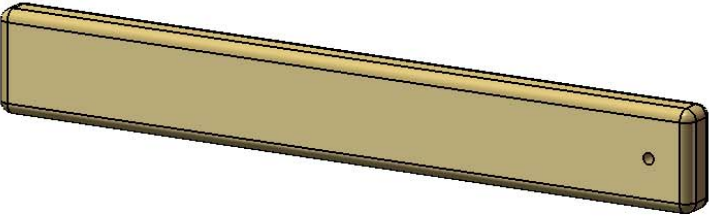
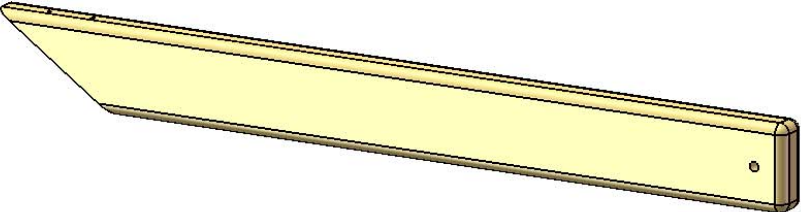
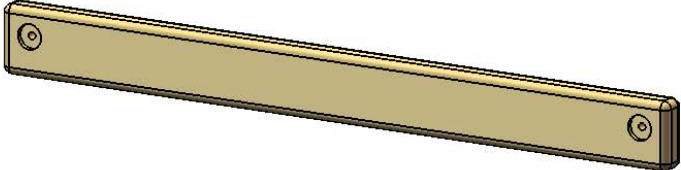

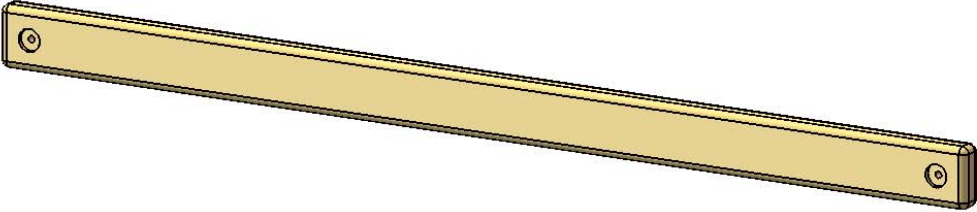
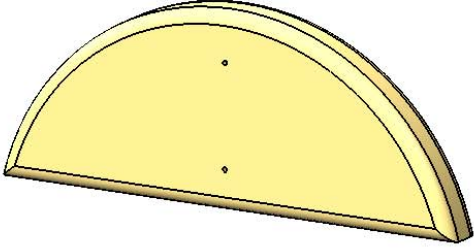
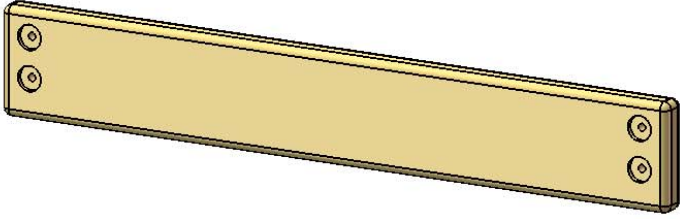
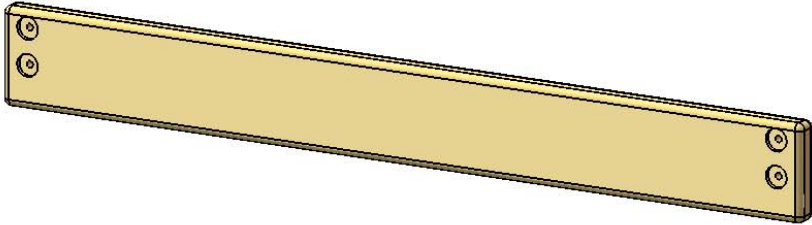
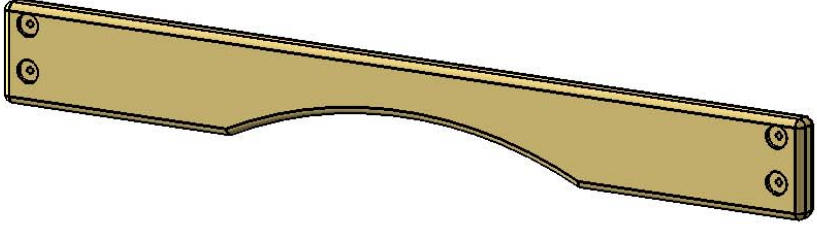
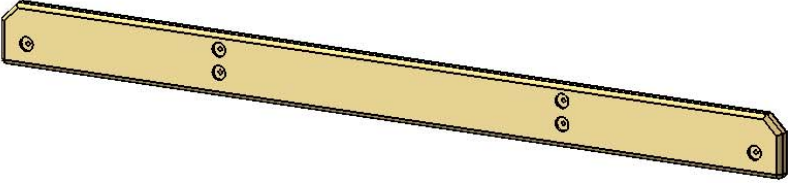
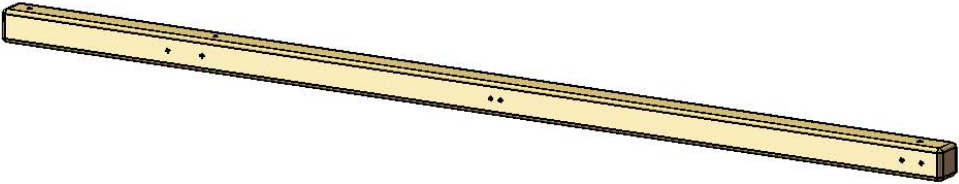

PICTURE	DESCRIPTION	QTY.
	<p>5/4 X 6 X 26-3/4" PANEL SLAT 125-6-2675-PS</p>	<p>4</p>
	<p>5/4 X 6 X 28" PANEL SLAT 125-6-2800-PS</p>	<p>8</p>
	<p>2 X 4 X 13" ANGLE SUPPORT 2-4-1300-AS</p>	<p>8</p>
	<p>2 X 4 X 14" BOTTOM PANEL BOARD 2-4-1400-BPB</p>	<p>2</p>
	<p>2 X 4 X 25" TARP CENTER POST 2-4-2500-TCP</p>	<p>2</p>
	<p>2 X 4 X 33-1/8" FORT SIDE SUPPORT 2-4-3313-FSS</p>	<p>2</p>
	<p>2 X 4 X 36" PANEL AND DECK SUPPORT 2-4-3600-PDS</p>	<p>6</p>



PICTURE	DESCRIPTION	QTY.
	<p>2 X 4 X 36" STRINGER 2-4-3600-S</p>	<p>1</p>
	<p>2 X 4 X 36" TARP BOARD 2-4-3600-TB</p>	<p>3</p>
	<p>2 X 4 X 36" ROCK WALL ROPE SUPPORT 2-4-3600-RWRS</p>	<p>1</p>
	<p>2 X 4 X 48" FRONT FACE BOARD 2-4-4800-FFB</p>	<p>1</p>
	<p>2 X 4 X 48" PANEL BOARD 2-4-4800-PB</p>	<p>3</p>
	<p>2 X 4 X 48" REAR TARP SUPPORT 2-4-4800-RTS</p>	<p>2</p>
	<p>2 X 4 X 50-1/2" ROCK WALL SIDE 2-4-5050-RWS</p>	<p>2</p>

PICTURE	DESCRIPTION	QTY.
	<p>2 X 4 X 58" CROSS MEMBER 2-4-5800-CM</p>	<p>1</p>
	<p>2 X 6 X 13-5/8" SUN 2-6-1363-S</p>	<p>2</p>
	<p>2 X 6 X 36" END SANDBOX BOARD 2-6-3600-ESB</p>	<p>1</p>
	<p>2 X 6 X 48" SANDBOX BOARD 2-6-4800-SB</p>	<p>2</p>
	<p>2 X 6 X 48" ARCH FACE BOARD 2-6-4800-AFB</p>	<p>1</p>
	<p>2 X 6 X 75" END SANDBOX BOARD 2-6-7500-ESB</p>	<p>1</p>
	<p>3 X 3 X 96" CORNER POST 1 3-3-9600-CP1</p>	<p>1</p>

PICTURE	DESCRIPTION	QTY.
	<p>3 X 3 X 96" CORNER POST 2 3-3-9600-CP2</p>	<p>1</p>
	<p>3 X 3 X 96" CORNER POST 3 3-3-9600-CP3</p>	<p>1</p>
	<p>3 X 3 X 96" CORNER POST 4 3-3-9600-CP4</p>	<p>1</p>
	<p>3 X 3 X 96" SWING LEG 3-3-9600-SL</p>	<p>2</p>
	<p>4 X 4 X 36" SWING BEAM MOUNT 4-4-3600-SBM</p>	<p>1</p>
	<p>4 X 4 X 73-1/2" TRAP ARM 4-4-7350-TA</p>	<p>1</p>
	<p>4 X 6 X 96" SWING BEAM 4-6-9600-SB</p>	<p>1</p>

PICTURE	DESCRIPTION	QTY.
	<p>LOONEY PERISCOPE 07-0021</p>	<p>1</p>
	<p>LOONEY TELESCOPE 07-0020</p>	<p>1</p>
	<p>CROWN 07-0019</p>	<p>1</p>
	<p>FLAG KIT 09-1014</p>	<p>2</p>

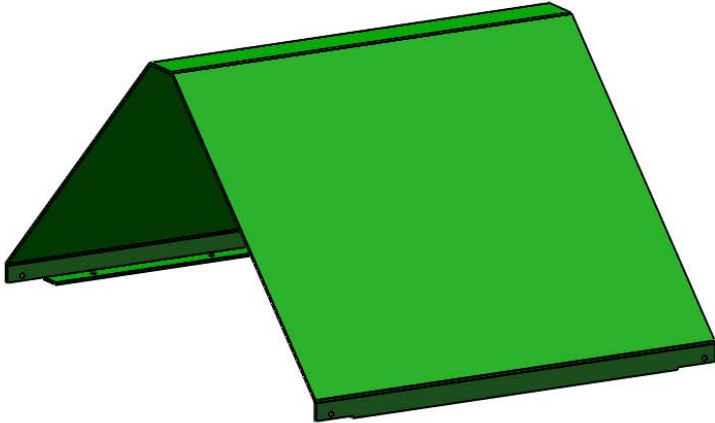
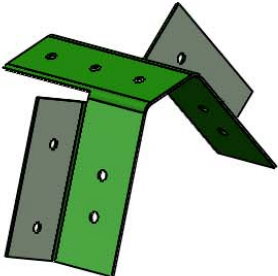
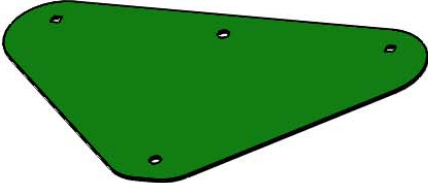
PICTURE	DESCRIPTION	QTY.
	STEERING WHEEL 07-0004	1
	SWING W/CHAINS 04-0002	2
	TRAPEZE BAR W/CHAINS 04-0006	1
	TIC TAC TOE (UNASSEMBLED) 07-0010	1
(NOT SHOWN)	MANUFACTURER NAME PLATE	1
(2401 HARDWARE BOX)	HARDWARE 11-0077	1
	WAVE SLIDE 03-0016-G	1

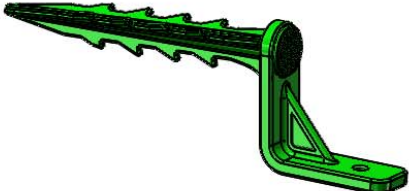
PICTURE	DESCRIPTION	QTY.
	<p>TARP 05-0014</p>	<p>1</p>
	<p>A-FRAME SWING LEG BRACKET 11-5010</p>	<p>1</p>
	<p>SWING PLATE 11-5002</p>	<p>1</p>
	<p>CHALKBOARD 07-0018</p>	<p>1</p>
	<p>GROUND STAKE (PAIR) 07-0016-P</p>	<p>3PR</p>

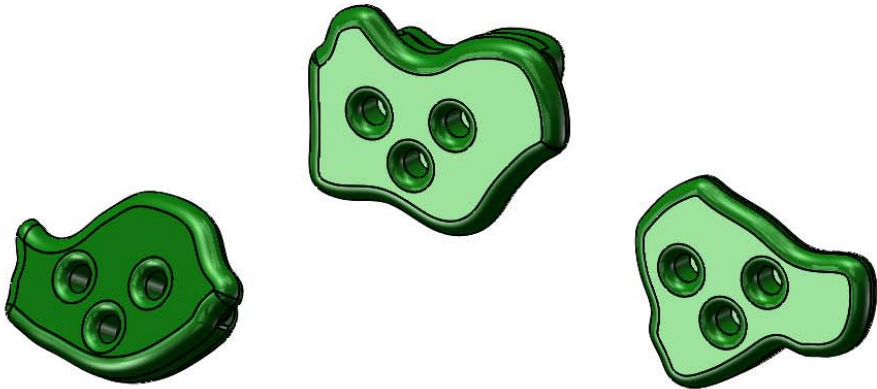
PICTURE	DESCRIPTION	QTY.
	CLIMBING ROCK (5 ROCKS ARE IN ONE BAG) 07-0008	5 ROCKS
	PLASTIC DORMER WINDOW 07-0029-G	2
	IRON DUCTILE SWING HANGER 11-4024	6
	10' ROPE GREEN	1
	90° GREEN BRACKET 11-5013	2
	SAFETY HANDLE (PAIR) 07-0005	1 PR

STEP 1: CORNER POST LAYOUT

1: THIS STEP IS CRITICAL TO BUILDING THE FORT PROPERLY. IF ANY MISTAKES ARE MADE HERE, YOU WILL NEED TO DIS-ASSEMBLE AND THE RE-ASSEMBLE TO MAKE YOUR CORRECTIONS.

2: LAY OUT EACH OF THE 3 X 3 X 96" CORNER POSTS IN THE AREA YOU INTEND ON BUILDING THE FORT SIDE OF THE PLAYSET.

3: USE THE DIAGRAM BELOW TO CORRECTLY IDENTIFY AND ORIENT THE POSTS IN THE CORRECT DIRECTION.

NOTE: THE SLIDE SIDE IS CONSIDERED THE FRONT OF THE PLAYSET WITH THE SWING BEAM EXTENDING OFF TO THE LEFT SIDE.

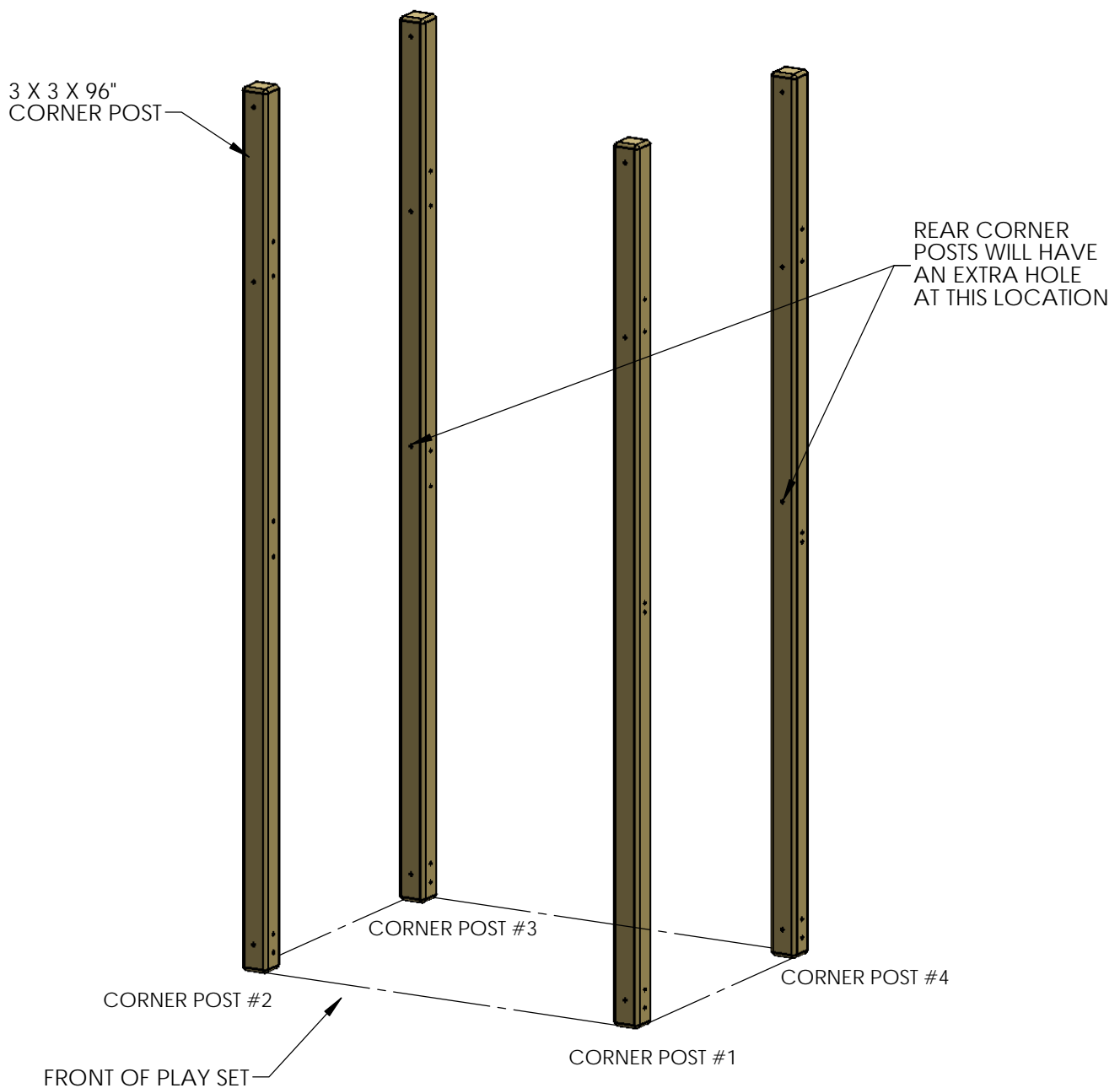

STEP 2: INSERTING T-NUTS INTO CORNER POSTS

- 1: USE A HAMMER TO SEAT THE T-NUTS AFTER INSERTING THEM INTO THE HOLES SHOWN IN THE DIAGRAM BELOW.
- 2: THE BARREL OF THE T-NUT SHOULD GO IN THE HOLE FIRST. HAMMER THE T-NUT UNTIL IS FLUSH/ALMOST FLUSH TO THE CORNER POSTS.

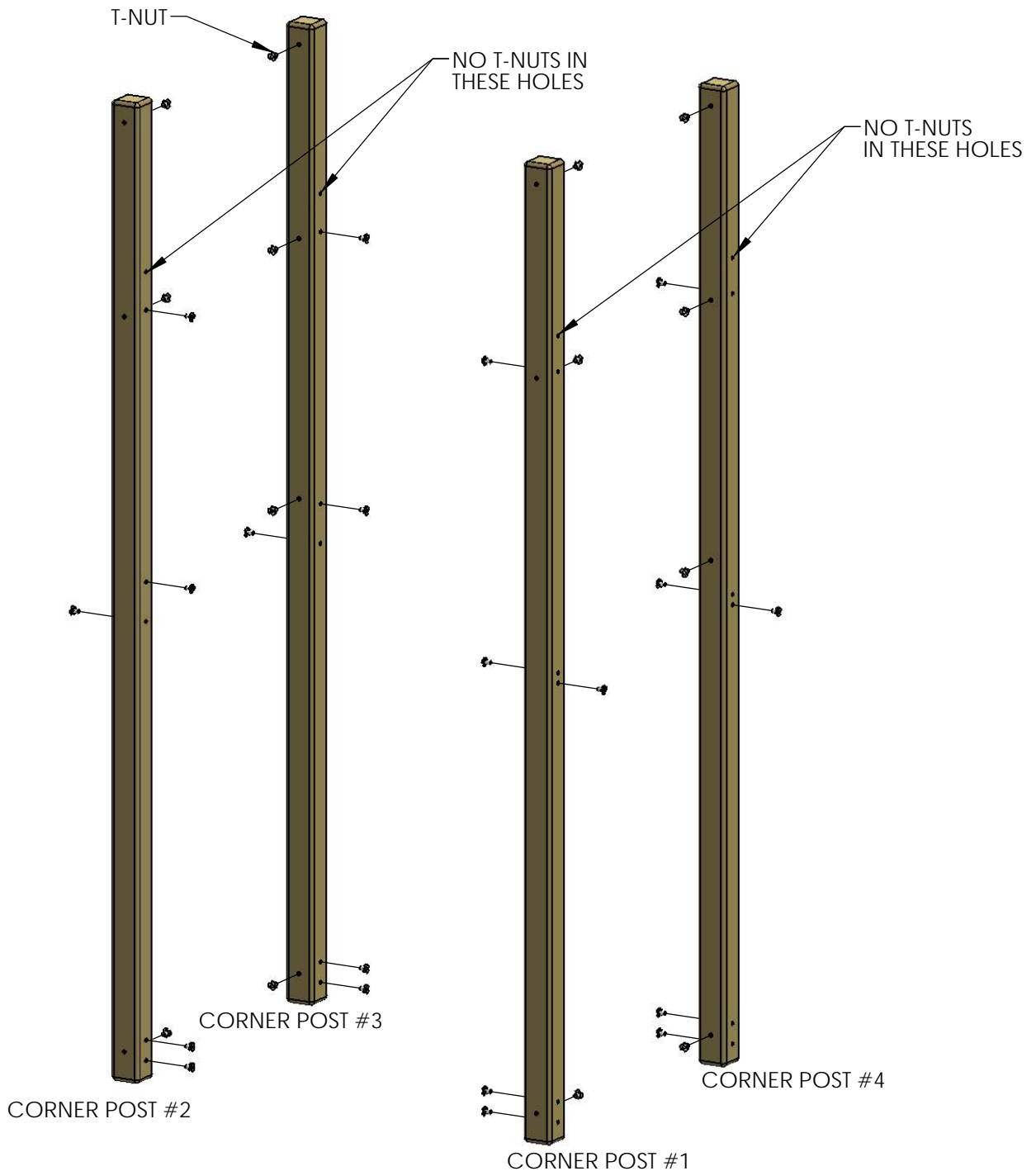

STEP 3: ATTACHING SANDBOX AND ROPE SUPPORT

1: THE 2 X 6 X 36" END SANDBOX BOARD (WITH FOUR PRE-DRILLED HOLES) ATTACHES TO THE BOTTOM OF THE RIGHTSIDE CORNER POSTS WITH 4" HEX BOLTS AND 5/16" WASHERS.

2: THE 2 X 4 X 36" PANEL AND DECK SUPPORT ATTACHES TO THE MIDDLE OF THE RIGHT SIDE OF THE CORNER POSTS, OFFSET HOLES DOWN, WITH 4" HEX BOLTS AND 5/16" WASHERS.

3: THE 2 X 4 X 36" ROCK WALL ROPE SUPPORT (WITH THREE PRE-DRILLED HOLES) ATTACHES TO THE TOP SET OF HOLES ON THE RIGHT SIDE OF THE CORNER POSTS, OFFSET HOLES UP, WITH 4" HEX BOLTS AND 5/16" WASHERS.

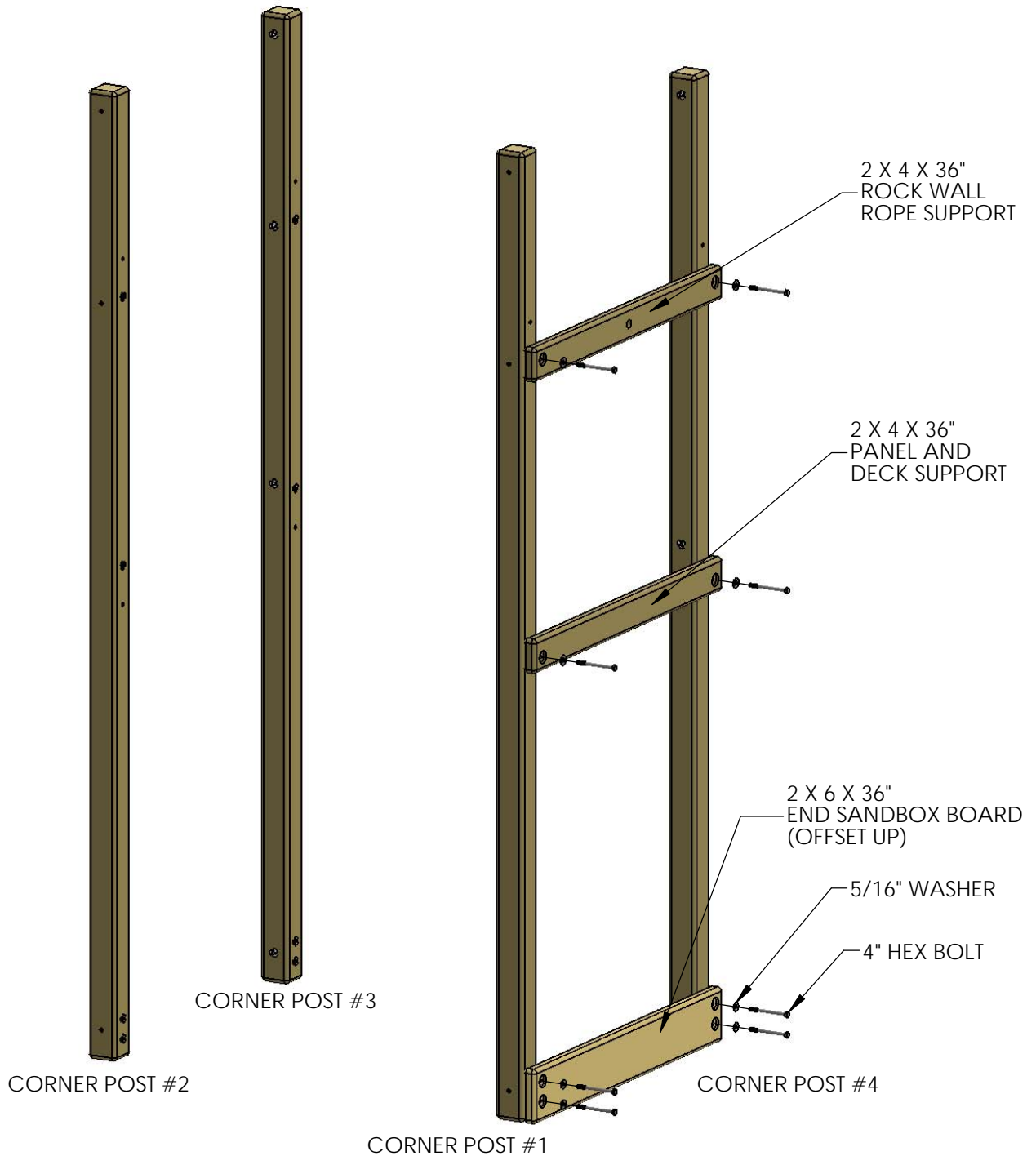

STEP 4: ATTACHING END SANDBOX BOARD

1: THE 2 X 6 X 75" END SANDBOX BOARD (WITH SIX PRE-DRILLED HOLES) ATTACHES TO THE BOTTOM OF THE LEFT SIDE CORNER POSTS WITH 4" HEX BOLTS AND 5/16" WASHERS.

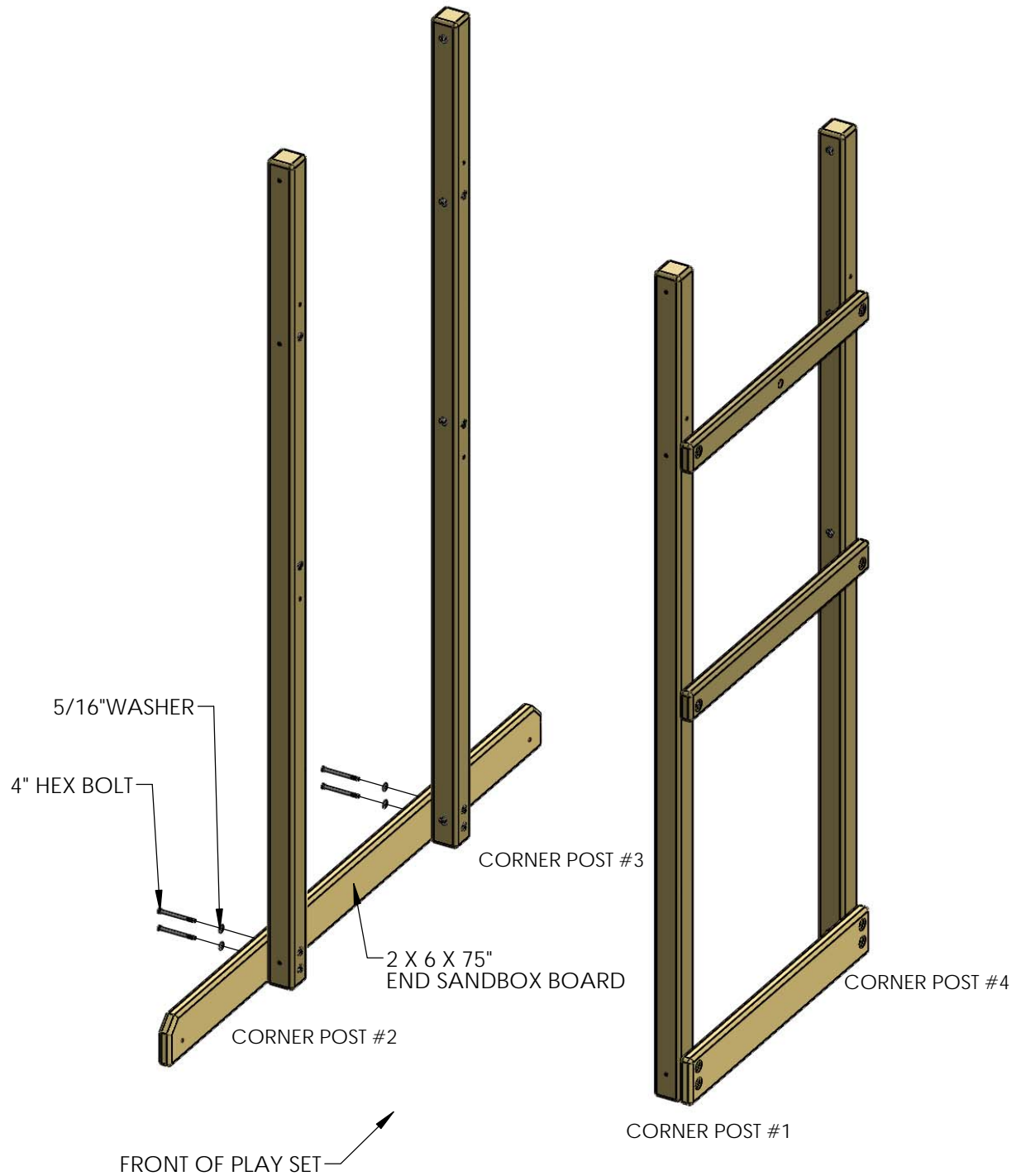

STEP 5: ATTACHING THE SANDBOX BOARDS

1: THE 2 X 6 X 48" SANDBOX BOARDS (OFFSET DOWN) ATTACH TO THE BOTTOM OF THE FRONT AND REAR CORNER POSTS WITH 4" HEX BOLTS , 3-1/2" LAG SCREWS AND 5/16" WASHERS.

2: INSTALL THE 4" HEX BOLTS AND 5/16" WASHERS FIRST.

3: SQUARE THE SANDBOX BOARD TO THE CORNER POSTS AND THEN PREDRILL 9/64" HOLES THROUGH THE BOTTOM HOLES INTO THE POSTS 2-1/2" DEEP.

4: ATTACH BOTTOM HOLES TO THE CORNER POSTS WITH 5/16 X 3-1/2" LAG SCREWS AND 5/16" WASHERS.

5: THE STRUCTURE SHOULD BE ABLE TO STAND ON ITS OWN, WITHOUT ANY SUPPORT, AT THIS STAGE.

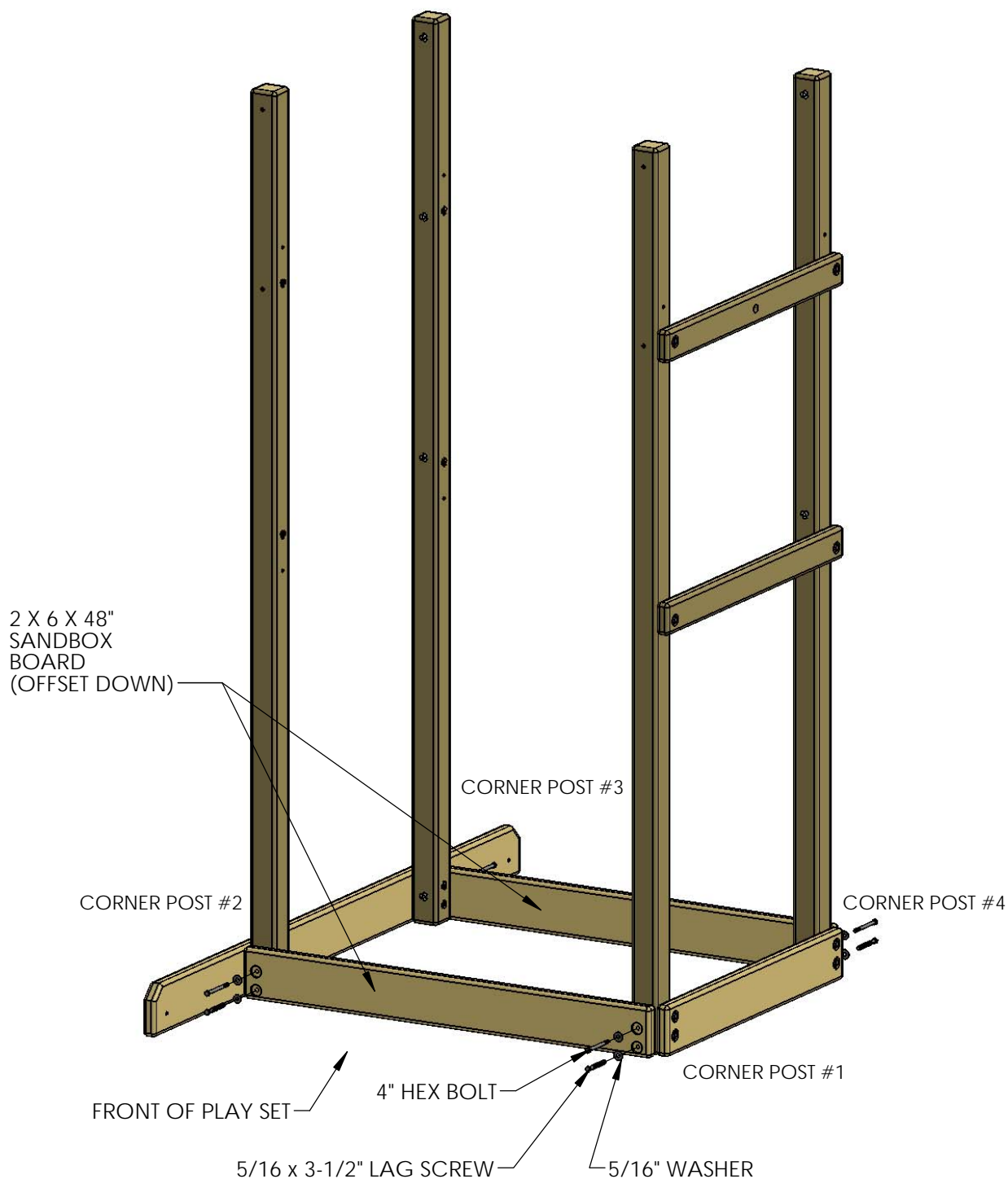

STEP 6: ATTACHING TARP SUPPORT BOARDS

1: THE 2 X 4 X 48" REAR TARP SUPPORT BOARDS (WITH THE PRE-DRILLED HOLES) ATTACH TO THE TOP OF THE FRONT AND REAR CORNER POSTS WITH 4" HEX BOLTS AND 5/16" WASHERS. **THE CENTER HOLE IS OFFSET DOWN.**

2: SQUARE THE TARP SUPPORT BOARDS TO THE CORNER POSTS AND THEN TIGHTEN THE HEX BOLTS BUT NOT SO TIGHT THAT YOU CRACK THE WOOD.

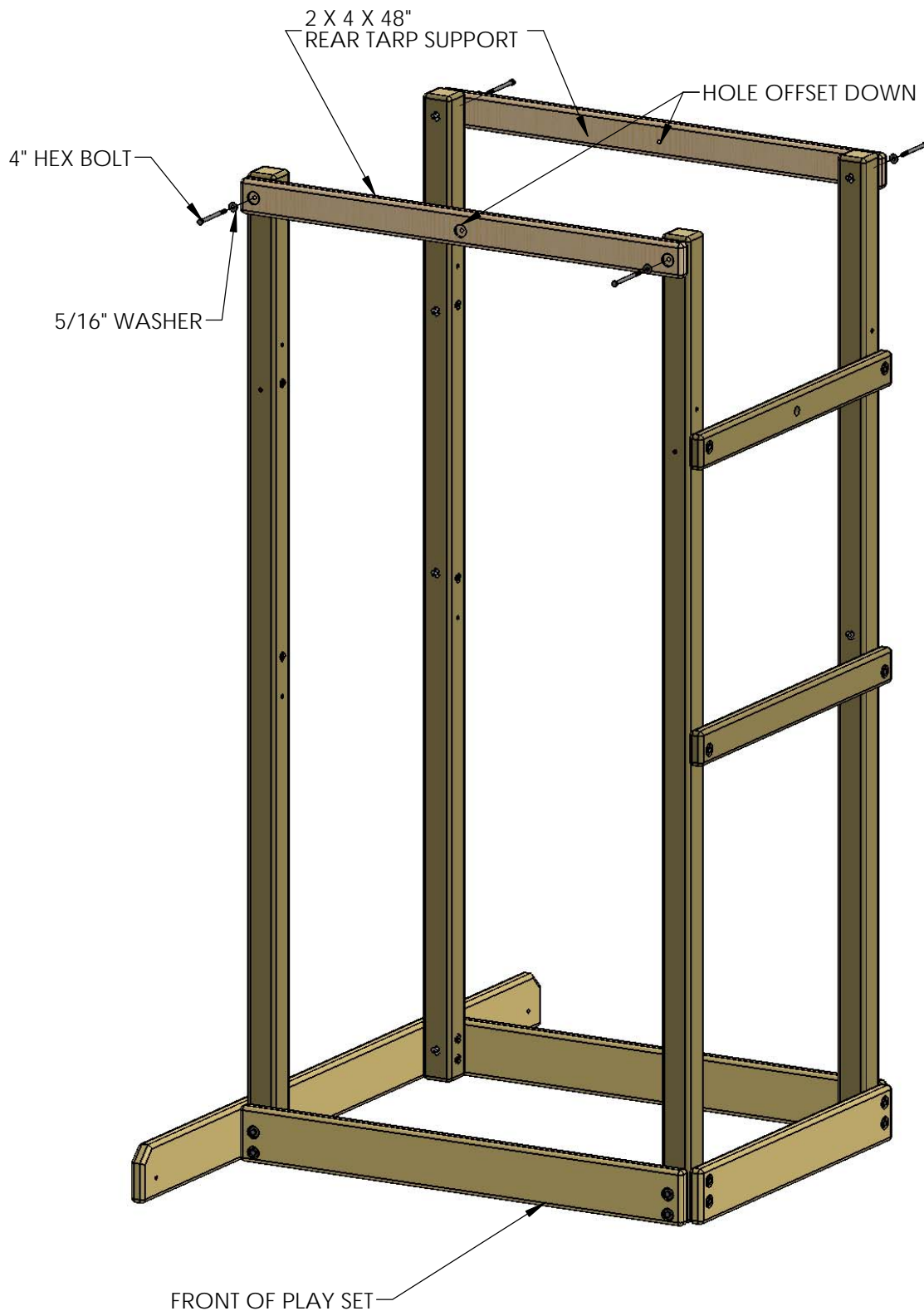

STEP 7: ATTACHING ARCH FACE BOARD AND DECK SUPPORTS

1: THE 2 X 6 X 48" ARCH FACE BOARD (WITH FOUR PRE-DRILLED HOLES) ATTACHES TO THE SET OF HOLES BELOW THE TARP SUPPORT BOARD. ATTACH THE TOP ARCH FACE BOARD HOLES USING 4" HEX BOLTS AND 5/16" WASHERS. PREDRILL 9/64" HOLES THROUGH THE BOTTOM HOLE 2-1/2" DEEP INTO THE CORNER POST. ATTACH THE BOTTOM HOLES WITH 5/16 X 3-1/2" LAG SCREWS AND 5/16" WASHERS.

2: THE 2 X 4 X 36" DECK SUPPORT BOARDS (WITH TWO PRE-DRILLED HOLES) ATTACH TO THE SET OF HOLES ABOVE THE SANDBOX BOARDS ON THE INSIDE OF THE LEFT AND RIGHT SIDE CORNER POSTS WITH 4" HEX BOLTS AND 5/16" WASHERS.

OFFSET HOLES SHOULD BE POINTED DOWN ON BOTH DECK SUPPORT BOARDS.

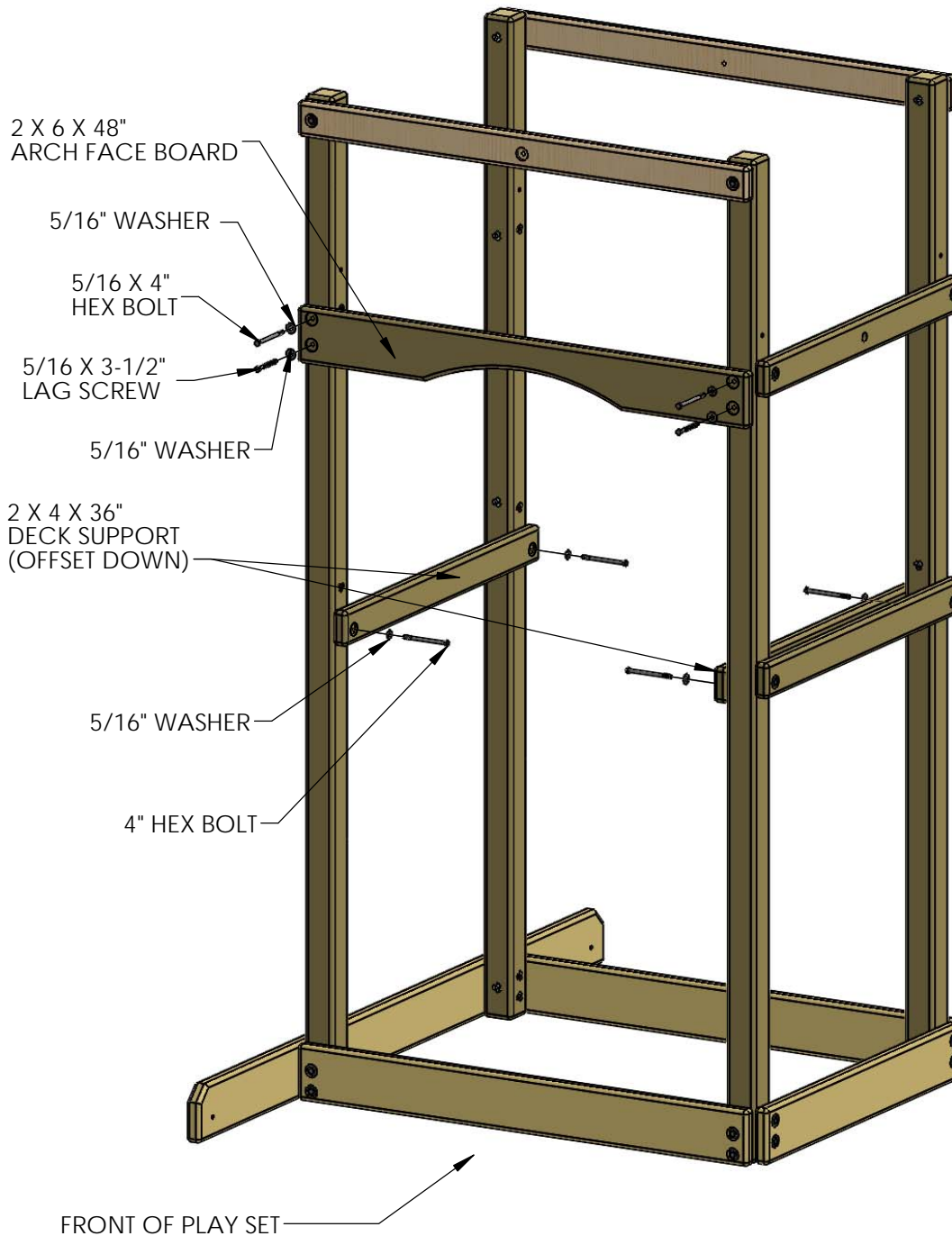

STEP 8: ATTACHING PANEL BOARDS

1: THE 2 X 4 X 48" PANEL BOARDS (WITH TWO PRE-DRILLED HOLES) ATTACH TO THE SET OF HOLES BELOW THE REAR TARP SUPPORT BOARD ON THE REAR OF THE FORT WITH 4" HEX BOLTS AND 5/16" WASHERS.

HOLES SHOULD BE OFFSET DOWN ON THE TOP BOARD.

HOLES SHOULD BE OFFSET UP ON THE BOTTOM BOARD.

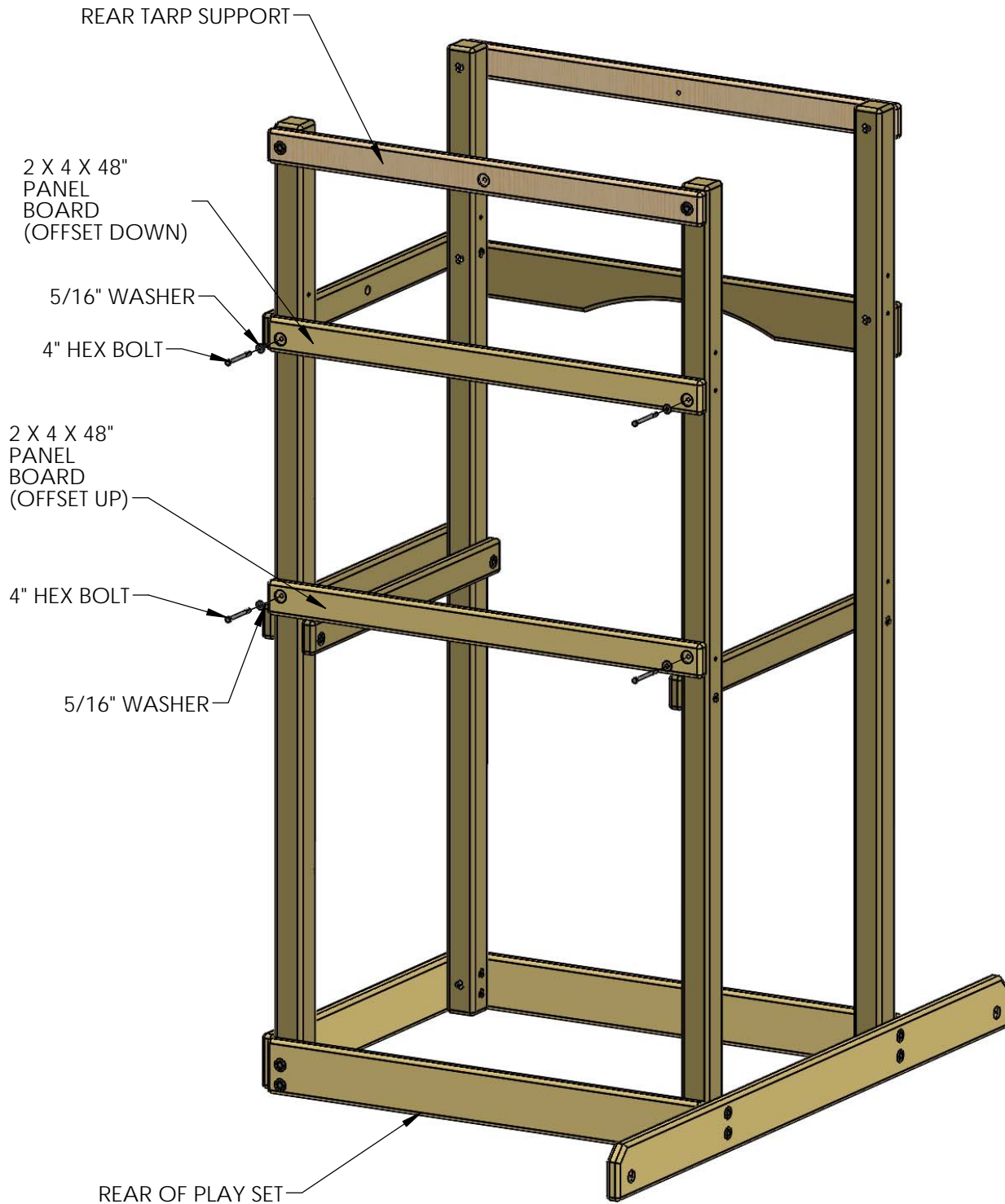

STEP 9: ATTACHING PANEL SUPPORTS AND SAFETY BOARD

- 1: THE 2 X 4 X 36" PANEL SUPPORT BOARD (TOP BOARD) SHOULD HAVE THE HOLES OFFSET UP. USE 4" HEX BOLTS AND 5/16" WASHERS TO SECURE THE BOARD TO THE CORNER POSTS.
- 2: THE 2 X 4 X 36" PANEL SUPPORT BOARD (BOTTOM BOARD) SHOULD HAVE THE HOLES OFFSET DOWN. USE 4" HEX BOLTS AND 5/16" WASHERS TO SECURE THE BOARD TO THE CORNER POSTS.
- 3: PLACE THE TOP OF THE PANEL SUPPORT (USED AS SAFETY BOARD) 24" FROM THE BOTTOM OF THE 2 X 6 BOARD.
- 4: PREDRILL 9/64" HOLES 2-1/2" DEEP THROUGH THE HOLES IN THE SAFETY BOARD.
- 5: FASTEN THE SAFETY BOARD TO THE CORNER POSTS WITH 5/16" X 3-1/2" LAG SCREWS AND 5/16" WASHERS.

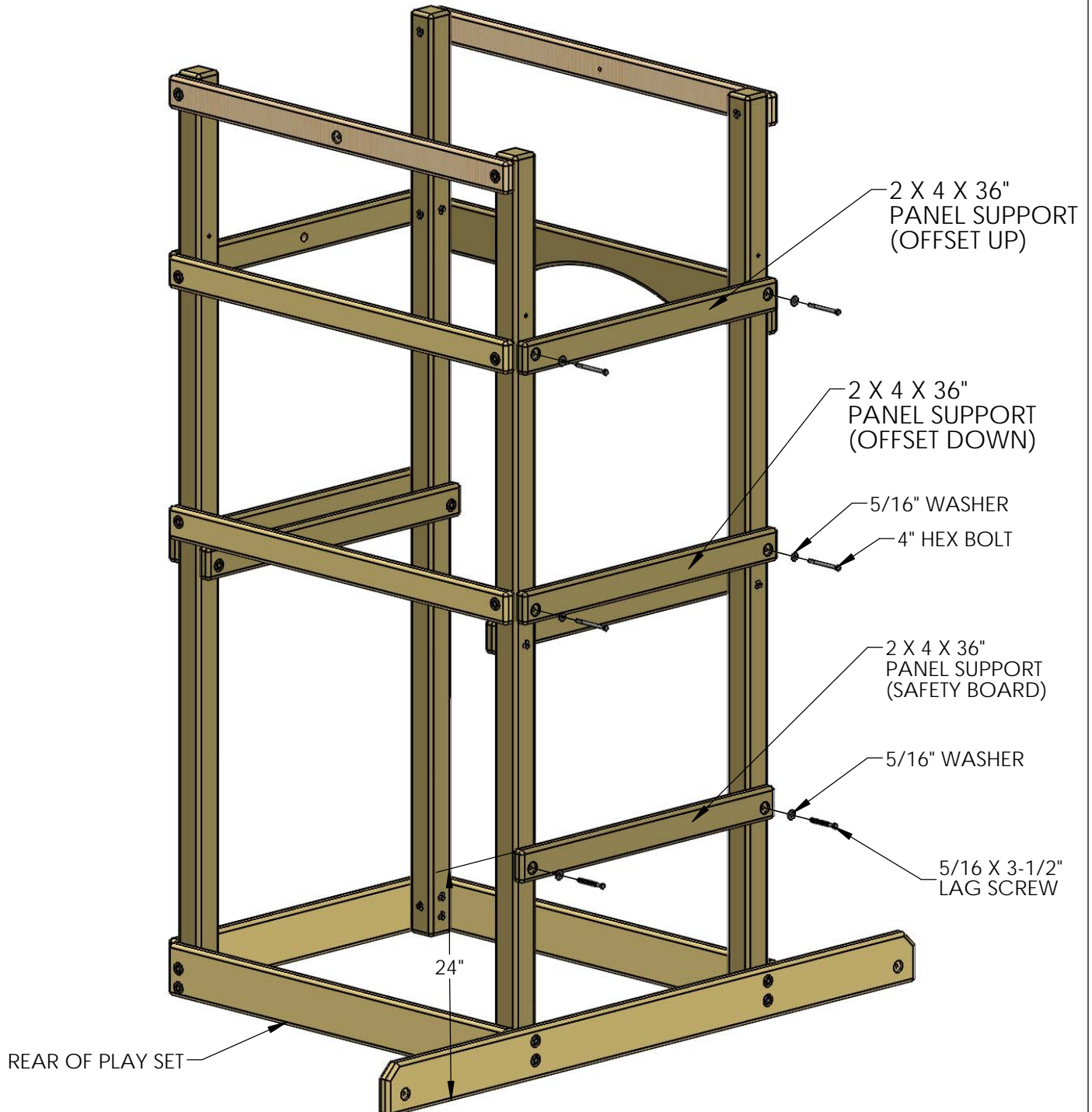

STEP 10: ATTACHING FORT SIDE SUPPORTS

1: LAY THE 2 X 4 X 33-1/8" FORT SIDE SUPPORTS ON A FLAT SURFACE WITH THE ANGLED ENDS ORIENTED THE WAY THEY WILL BE INSTALLED ONTO THE FORT. PLACE A T-NUT IN THE PRE-DRILLED HOLE ON EACH END AND SECURE WITH HAMMER.

2: THE 2 X 4 X 33-1/8" FORT SIDE SUPPORTS (WITH ANGLED ENDS) ATTACH TO THE HOLES ON THE ENDS OF THE 2 X 6 X 75" END SANDBOX BOARD ON THE INSIDE WITH 2-1/2" HEX BOLTS AND 5/16" WASHERS. THE ANGLED ENDS SHOULD REST FLUSH AGAINST THE CORNER POSTS. SEE DETAIL A FOR CLARIFICATION IF NECESSARY.

3: ENSURE THAT THE TWO FORT SIDE SUPPORTS ARE ATTACHED PROPERLY TO THE SANDBOX BOARD BEFORE SECURING THEM TO THE CORNER POSTS. USE A 2-1/2" WOOD SCREW IN THE TOP HOLE OF THE SUPPORT, THEN USE A 3" WOOD SCREW IN THE BOTTOM HOLE OF THE SUPPORT. SEE DETAIL B FOR CLARIFICATION IF NECESSARY.

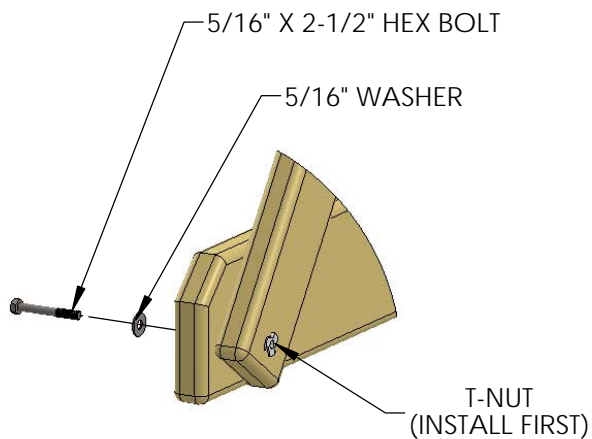

DETAIL A
SCALE 1 : 7

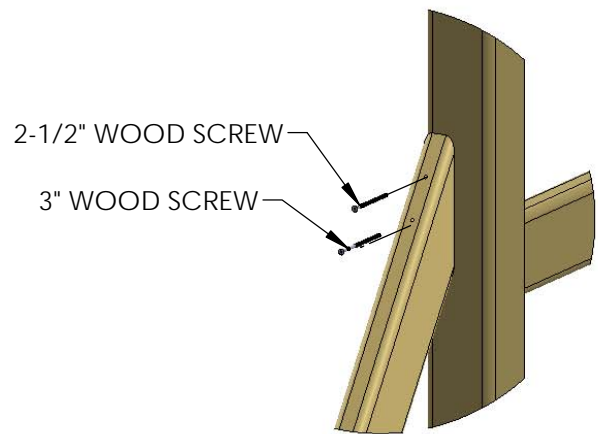

DETAIL B
SCALE 2 : 15

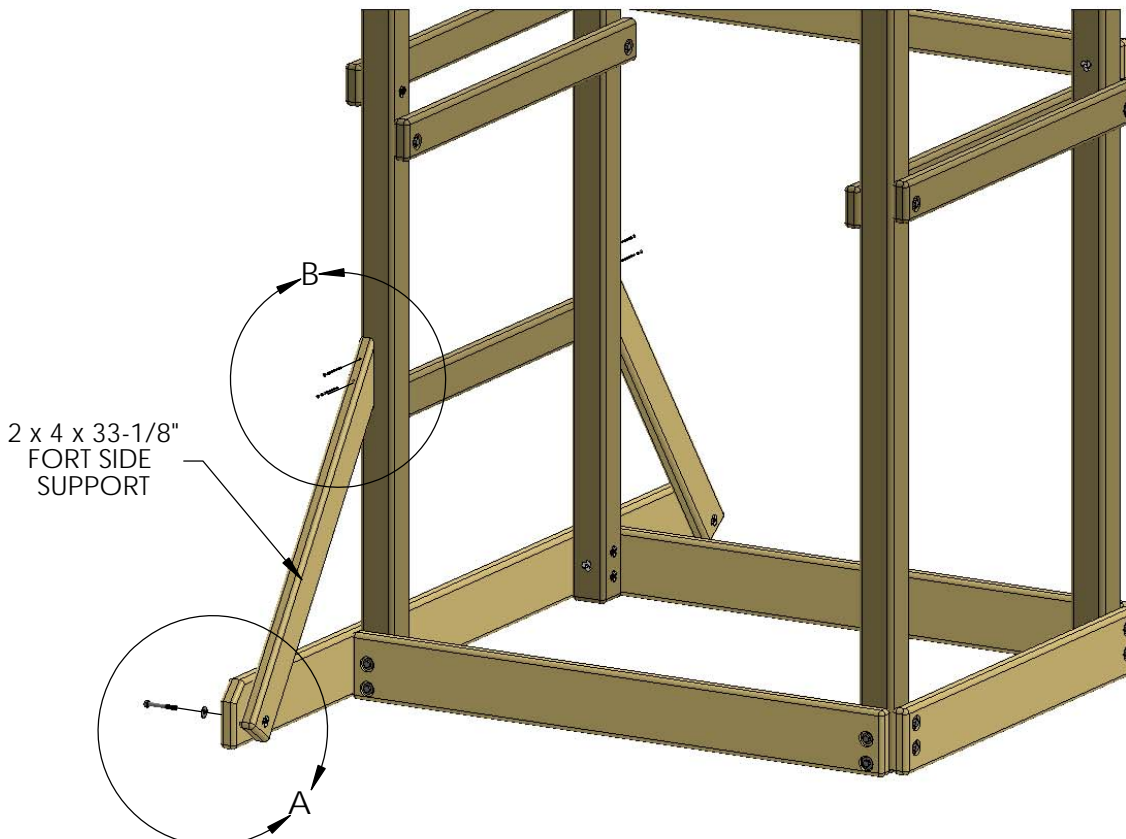

STEP 11: ATTACHING THE DECK BOARDS AND DECK SPACERS

1: THE 5/4 X 3 X 41-7/8" DECK SPACERS MOUNT BETWEEN THE REAR CORNER POSTS AND BETWEEN THE FRONT CORNER POSTS FLUSH TO THE EDGES. DRIVE THE 2" WOOD SCREWS THROUGH THE PREDRILLED HOLES INTO THE DECK SUPPORTS.

2: SIX 5/4 X 5 X 48" DECK BOARDS WILL LAY ACROSS THE DECK SUPPORTS, FLUSH TO THE FRONT CORNER POST.

3: SPACE DECK BOARDS EVENLY ACROSS THE DECK SUPPORTS BETWEEN THE DECK SPACERS. SECURE WITH 2" WOOD SCREWS THROUGH THE PREDRILLED HOLES TO THE DECK SUPPORTS.

2" WOOD SCREWS

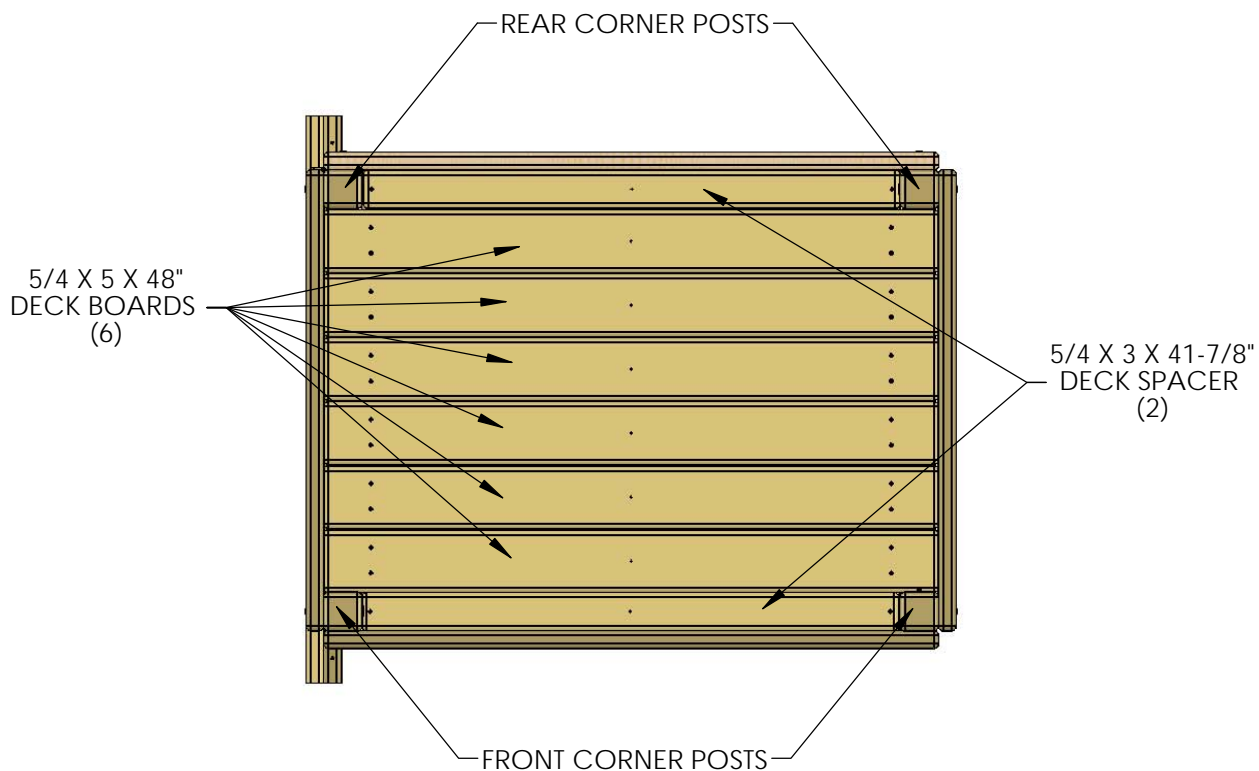
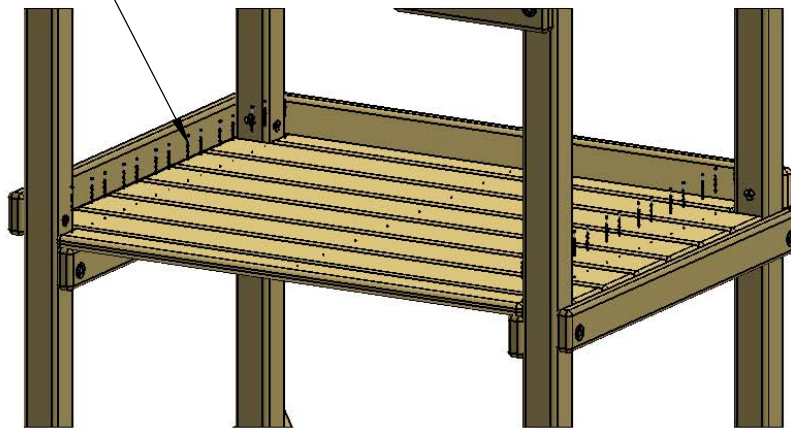

STEP 12: ATTACHING THE STRINGER

1: FIND THE 2 X 4 X 36" STRINGER WITHOUT HOLES.

2: PLACE THE STRINGER UNDERNEATH THE CENTER OF THE DECK BOARDS (USE THE HOLE AT THE CENTER AS A GUIDE) MAKE SURE THE END OF THE CENTER DECK SUPPORT IS FLUSH WITH THE DECK SPACER ROUND EDGE.

3: ATTACH IT WITH 2" WOOD SCREWS THROUGH THE DECK BOARDS PREDRILLED HOLES AND INTO THE STRINGER BELOW.

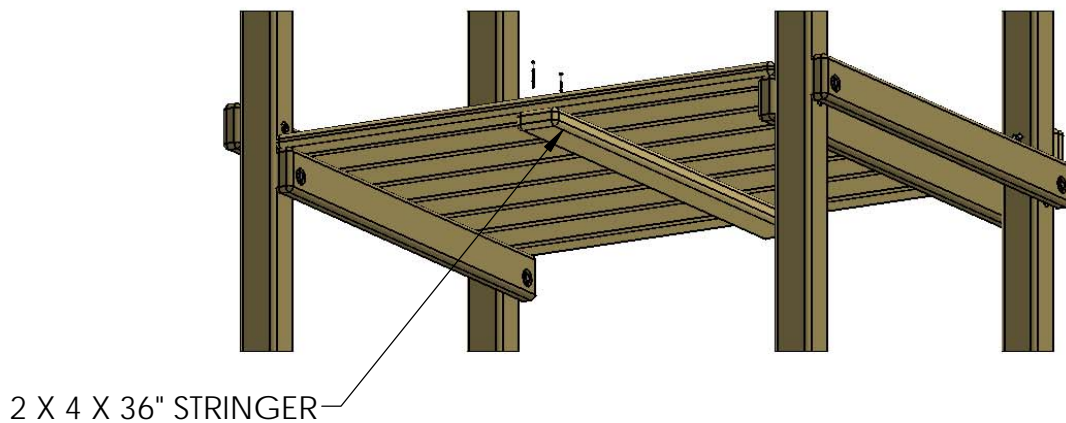
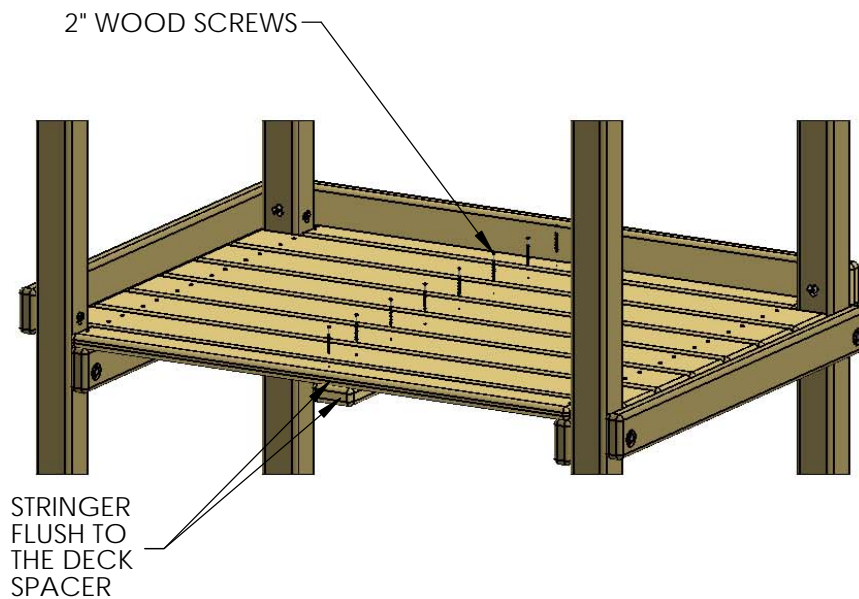

STEP 13: ATTACHING THE FRONT FACE BOARD

1: THE TOP EDGE OF THE 2 X 4 X 48" FRONT FACE BOARD WILL BE FLUSH TO THE TOP OF THE DECK SPACER. SECURE THE FRONT FACE BOARD TO THE CORNER POSTS WITH THREE 2-1/2" WOOD SCREWS PER SIDE.

2: INSTALL TWO 3" WOOD SCREWS THROUGH THE CENTER OF THE FRONT FACE BOARD INTO THE STRINGER AS SHOWN BELOW.

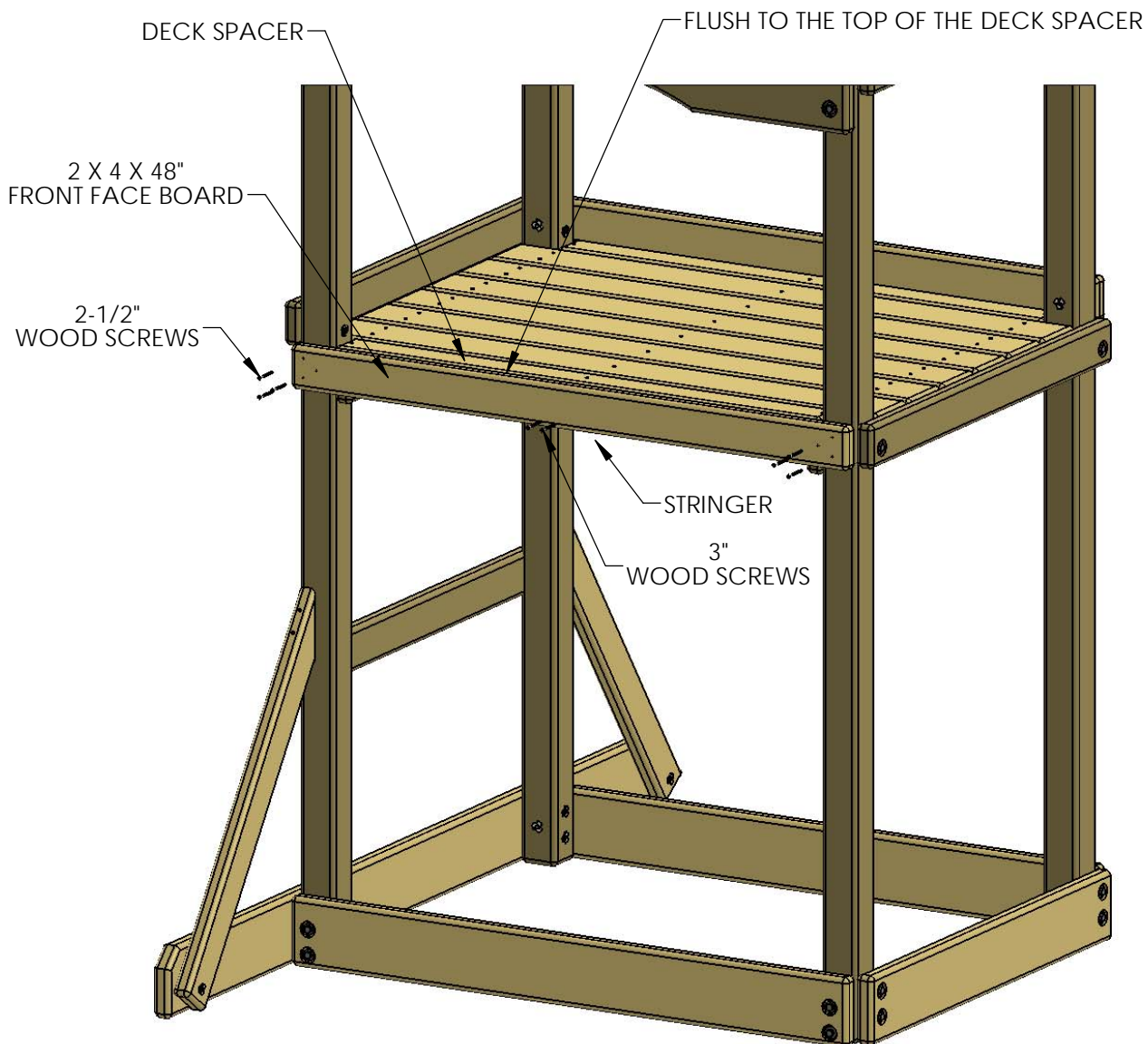

STEP 14: ATTACHING THE PANEL BOARD

1: THE 2 X 4 X 48" PANEL BOARD SHOULD HAVE THE HOLES OFFSET DOWN. MAKE THE TOP OF THE BOARD FLUSH WITH THE BOTTOM OF THE PANEL BOARD (TOP)

2: PREDRILL 9/64" HOLES 2-1/2" DEEP THROUGH THE HOLES IN THE PANEL BOARD. ATTACH THE PANEL BOARD USING 5/16 X 3-1/2" LAG SCREWS AND 5/16" WASHERS.

3: INSTALL TWO 3" WOOD SCREWS THROUGH THE CENTER OF THE PANEL BOARD INTO THE STRINGER AS SHOWN BELOW.

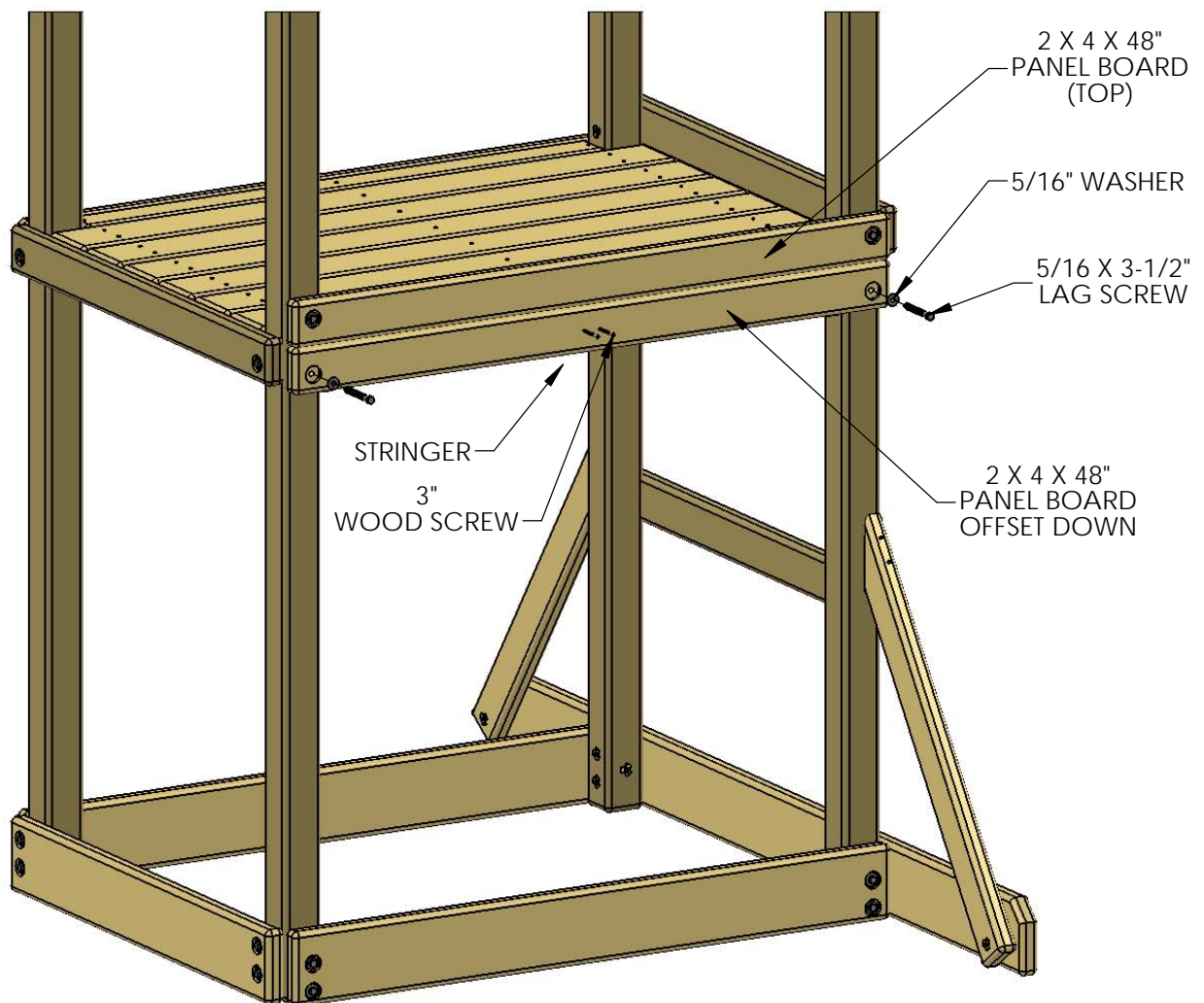

STEP 15: ANGLE SUPPORTS

1: EIGHT 2 X 4 X 13" ANGLE SUPPORTS ARE MOUNTED UNDER THE DECK OF THE PLAY SET TO THE 2 X 4 X 36" DECK SUPPORTS, 2 X 4 X 48" FRONT FACE BORD AND 2 X 4 X 48" PANEL BOARD. THE TOP OF THE ANGLE SUPPORT SHOULD BE FLUSH OR LOWER THAN THE TOP OF THE DECK SUPPORT.

2: AT THE TOP USE 2-1/2" WOOD SCREWS THROUGH THE ANGLE SUPPORT INTO THE DECK SUPPORT, FRONT FACE AND PANEL BOARD. ON THE RIGHT SIDE USE 2-1/2" WOOD SCREWS THROUGH THE DECK SUPPORT INTO THE ANGLE SUPPORT. AT THE BOTTOM USE ONE 2" AND ONE 3" WOOD SCREW TO FASTEN THE ANGLE SUPPORT TO THE CORNER POST.

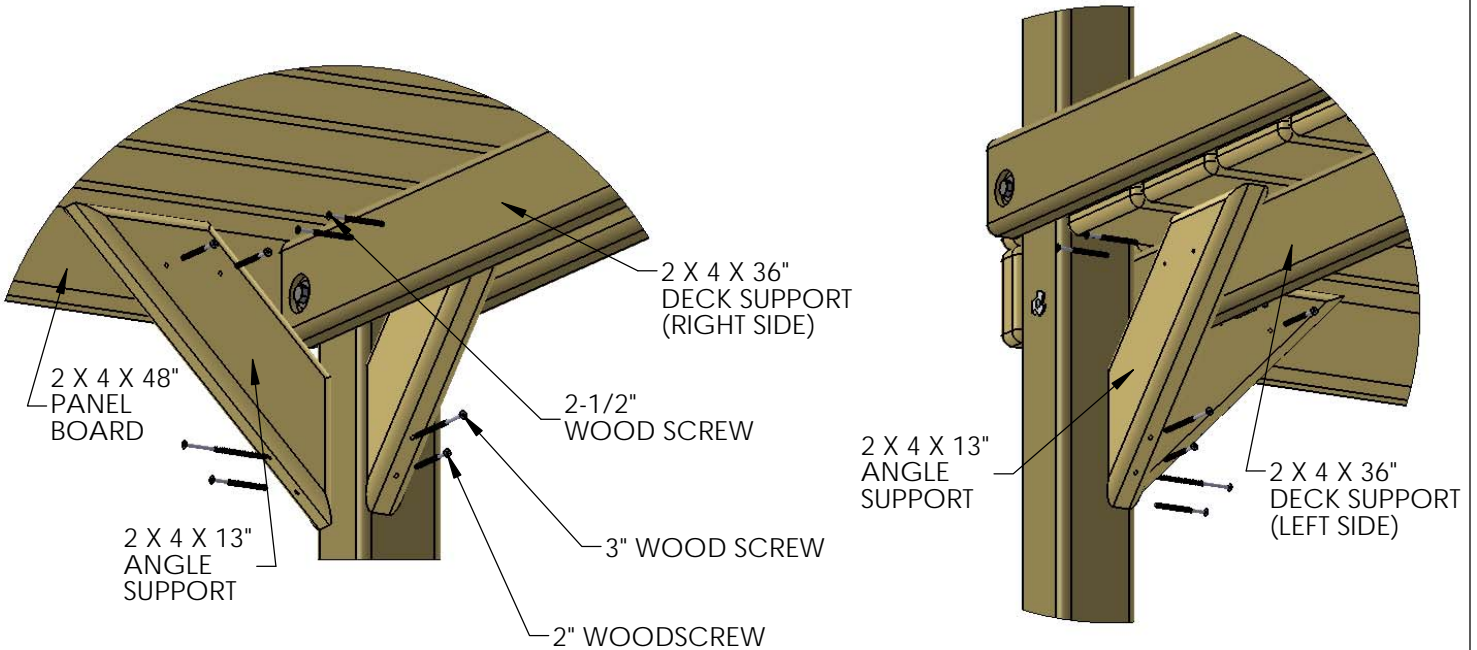

DETAIL A
SCALE 1 : 6

DETAIL B
SCALE 2 : 13

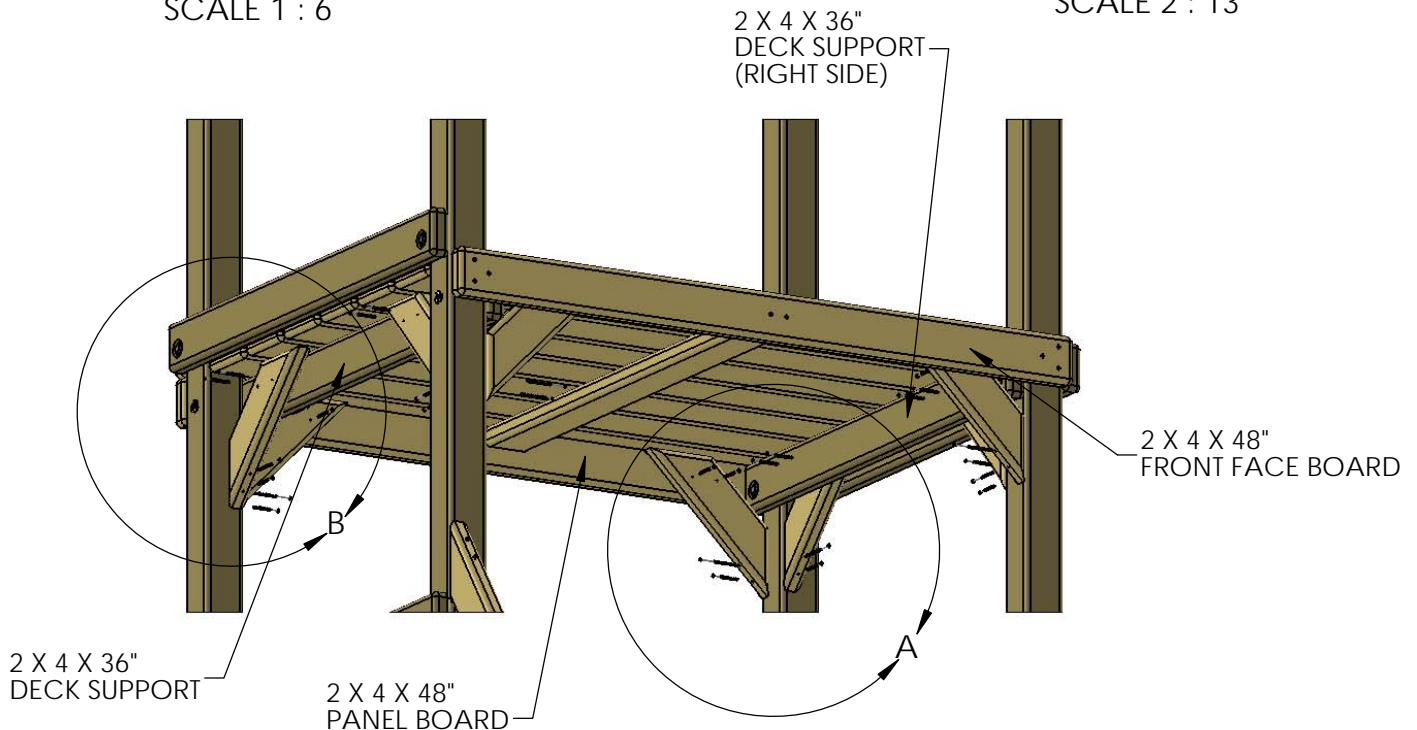

STEP 16: SWING BEAM PLATE

- 1: LAY THE SWING BEAM MOUNT ON A FLAT SURFACE WITH THE THREE COUNTER SUNK CENTER HOLES FACING THE GROUND, THE COUNTER SUNK HOLES ON THE ENDS MUST BE FACING TOWARDS YOU.
- 2: PLACE THE SWING BEAM PLATE ON TOP OF THE SWING BEAM MOUNT, LINING UP PILOT HOLES.
- 3: FASTEN THE SWING BEAM PLATE TO THE SWING BEAM MOUNT ON THE OUTSIDE HOLES USING 3/8" X 3-1/2" CARRIAGE BOLTS ON TOP, AND 3/8" WASHERS WITH 3/8" LOCK NUTS ON THE BOTTOM. PLACE GREEN BOLT COVERS OVER EXPOSED THREADS AFTER SECURING.
- 4: LEAVE THE MIDDLE HOLE EMPTY, IT WILL BE USED LATER.

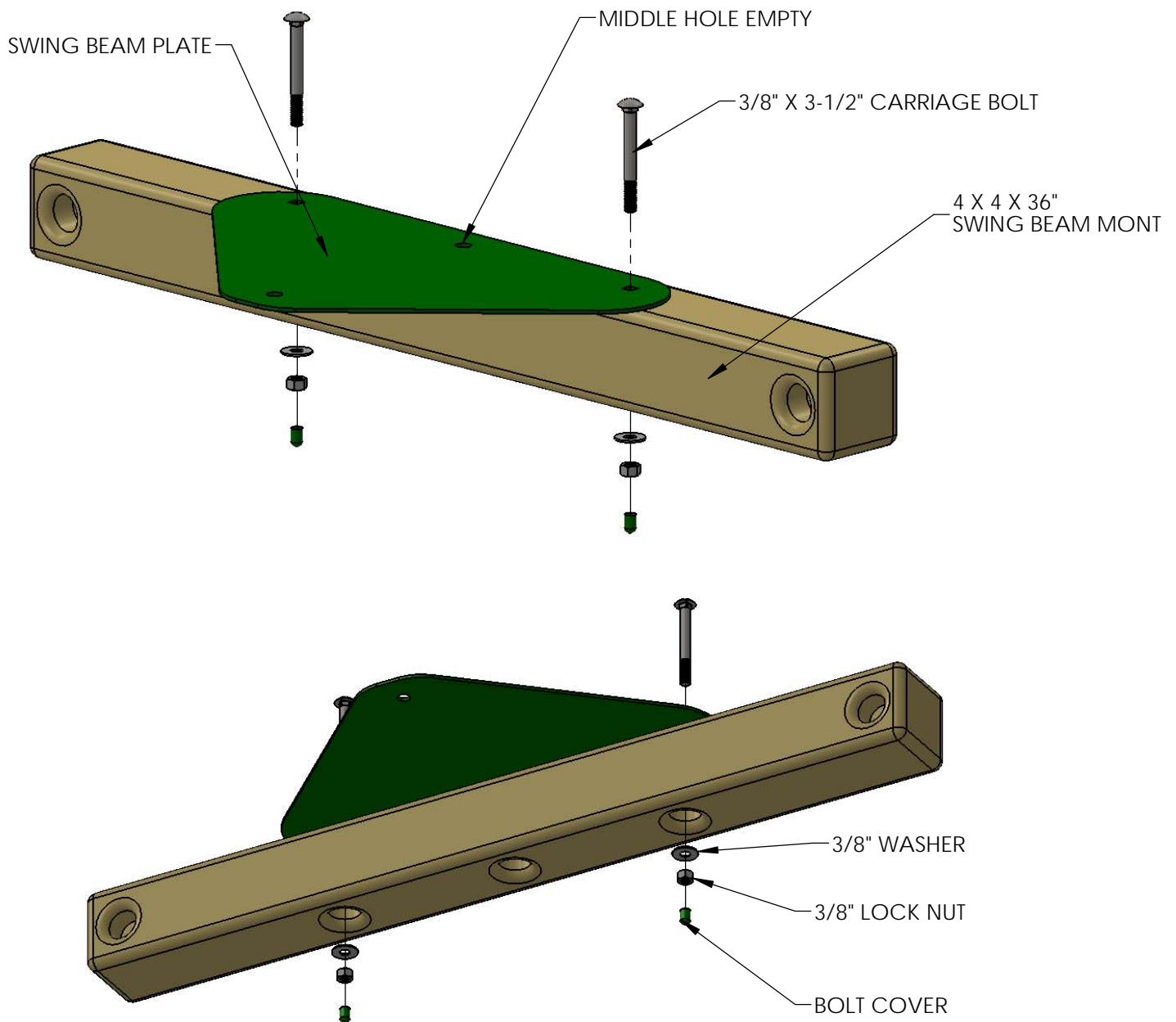

STEP 17: IRON DUCTILES

1: LINE UP THE HOLES OF THE IRON DUCTILES WITH THE HOLES IN THE SWING BEAM.

2: FASTEN THE IRON DUCTILES TO THE SWING BEAM USING 3/8" X 7" CARRIAGE BOLTS WITH TORQUE WASHERS ON TOP OF THE SWING BEAM, AND 3/8" WASHERS WITH 3/8" LOCK NUTS ON THE BOTTOM. PLACE BOLT COVERS OVER EXPOSED THREADS AFTER SECURING.

3: FASTEN IRON DUCTILES TO THE TRAP ARM IN THE SAME MANNER THAT YOU FASTENED THEM TO THE SWING BEAM, USING 3/8" X 4-1/2" CARRIAGE BOLTS WITH TORQUE WASHERS ON TOP OF THE TRAP ARM, AND 3/8" LOCKNUTS WITH 3/8" WASHERS ON THE BOTTOM. PLACE BOLT CAPS OVER ANY EXPOSED THREADS AFTER SECURING.

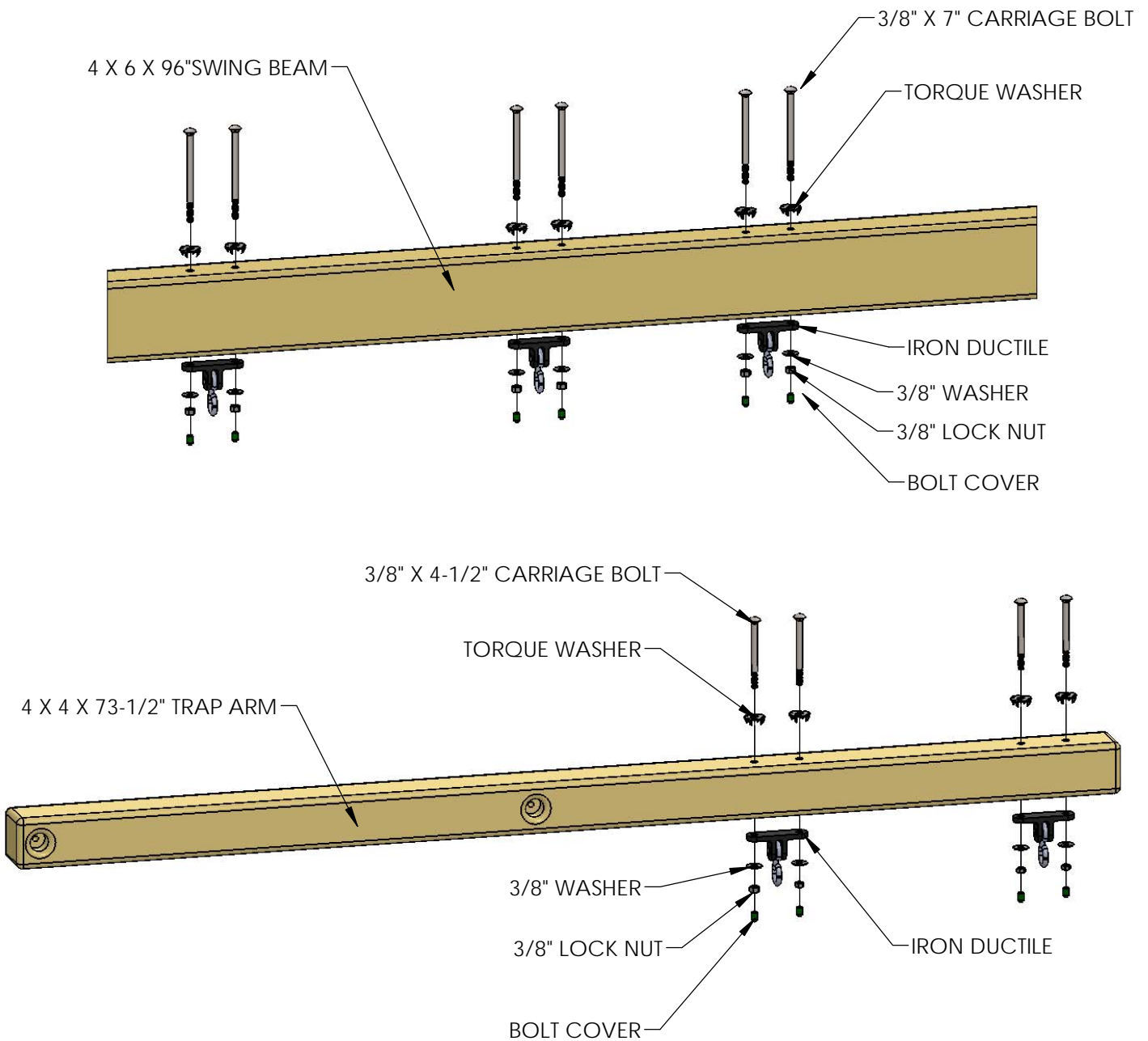

STEP 18: ATTACHING THE SWING BEAM SUPPORT AND TRAP ARM

1: THE 4 X 4 X 36" SWING BEAM MOUNT HAS COUNTER-SUNK HOLES IN THE CENTER AND ON THE ENDS. INSTALL THE SWING BEAM MOUNT SO THAT THE COUNTER-SUNK HOLES ON EACH END OF THE BEAM FACE OUT, AND THE COUNTER-SUNK HOLES AT THE CENTER FACE DOWN.

2: FASTEN THE SWING BEAM MOUNT TO THE CORNER POSTS USING 3/8" X 6-1/2" CARRIAGE BOLTS WITH TORQUE WASHERS. PLACE THE CARRIAGE BOLT INTO THE TORQUE WASHER, THEN INTO THE HOLE OF THE CORNER POST AND SET WITH A HAMMER, USE 3/8" WASHERS WITH 3/8" LOCK NUTS TO SECURE THE SWING BEAM MOUNT FROM THE OUTSIDE. PLACE BOLT COVERS OVER THE EXPOSED THREADS AFTER SECURING.

3: THE 4 X 4 X 73-1/2" TRAP ARM WILL ATTACH TO THE UNIT IN THE SAME MANNER AS THE SWING BEAM MOUNT. THE TRAP ARM WILL MOUNT ON THE OPPOSITE SIDE OF THE FRONT THAT THE SWING BEAM MOUNT WAS MOUNTED ON.

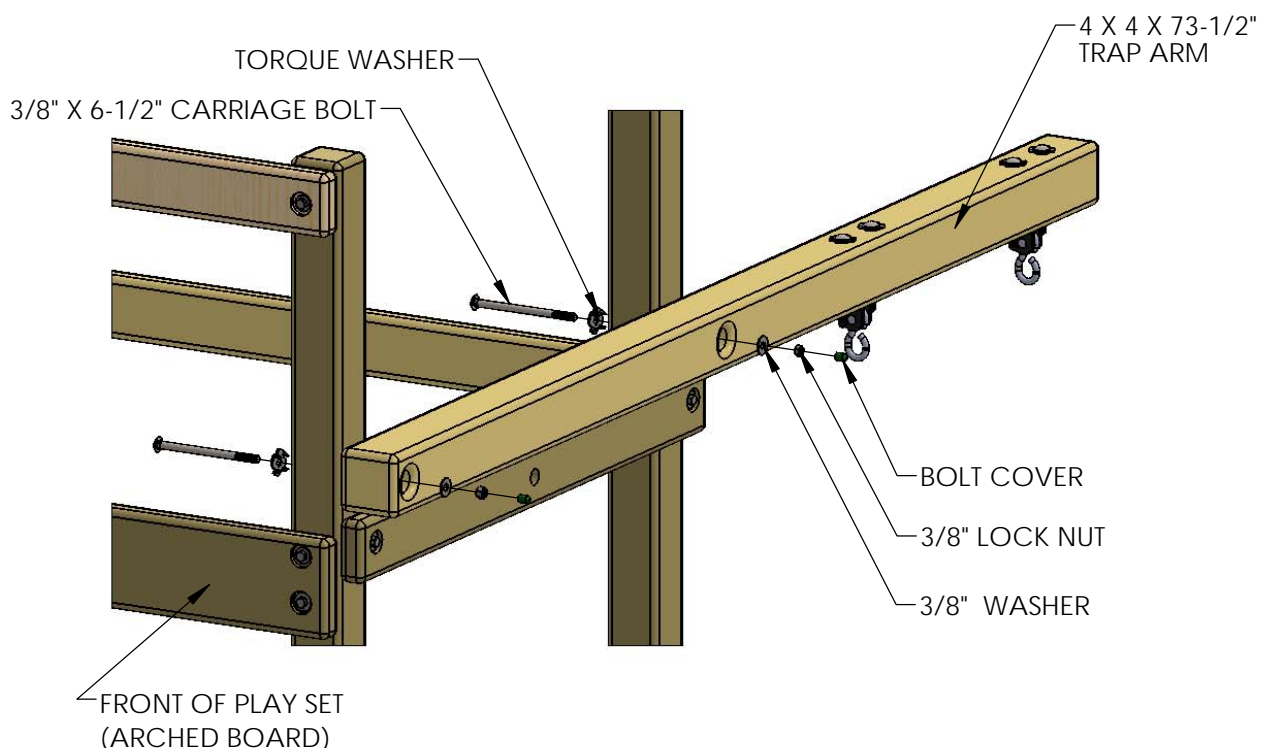
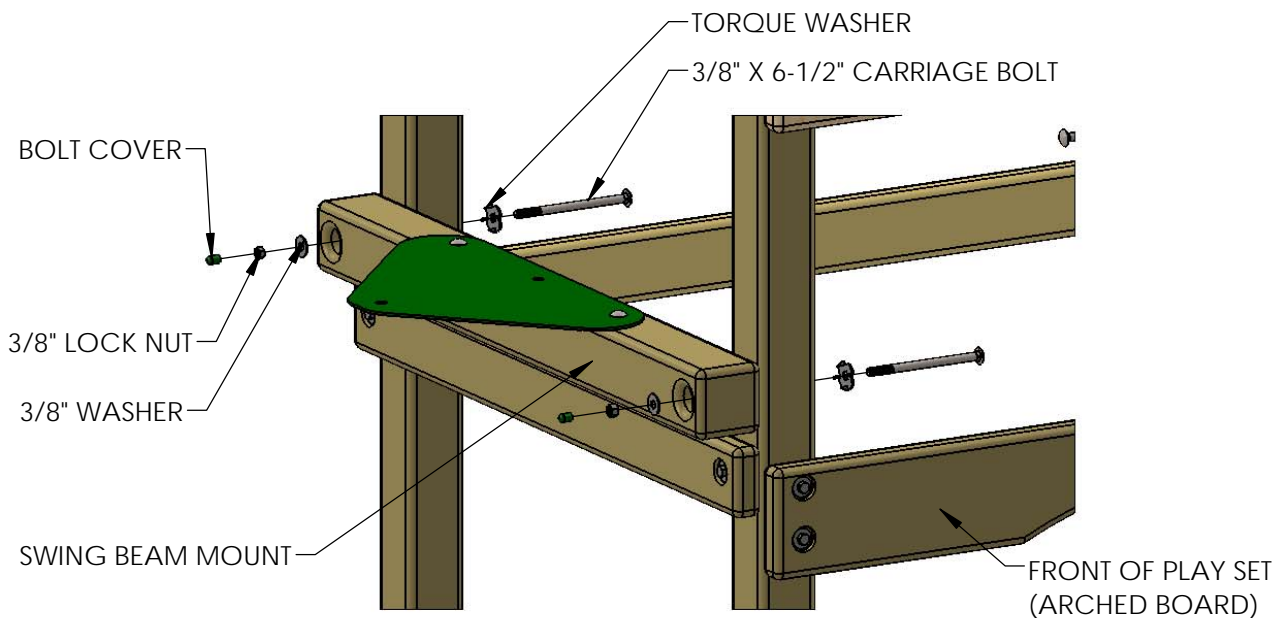

STEP 19: ROCK WALL

- 1: FIND TWO 2 X 4 X 50-1/2" ROCK WALL SIDES.
- 2: POSITION THE ROCK WALL SIDES SO THAT THE HOLES IN THE BOARDS ARE BOTH FACING THE SAME WAY.
- 3: INSERT T-NUTS INTO THE INSIDE OF THE ROCK WALL SIDES AND SET WITH A HAMMER.

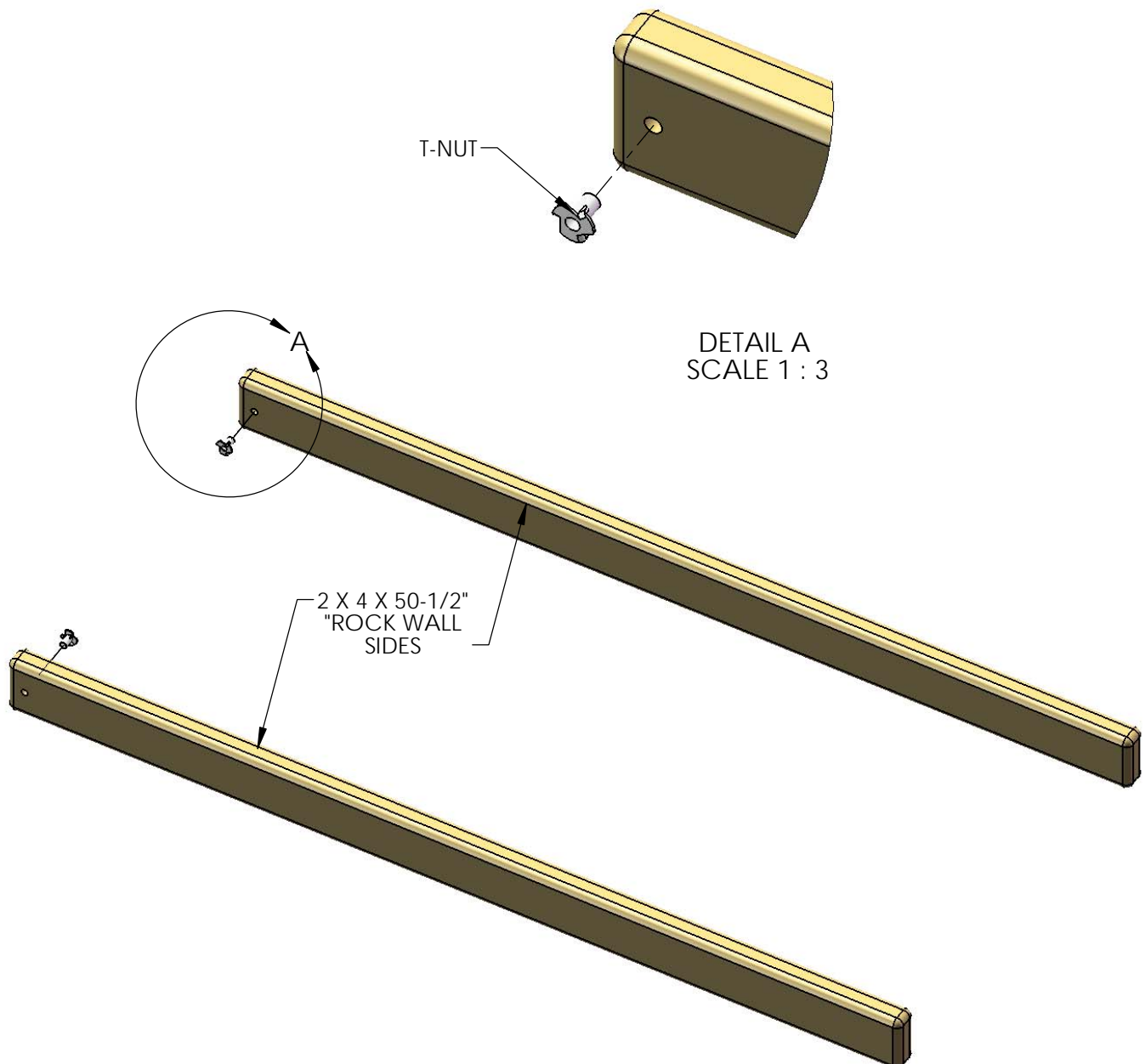

STEP 20: ROCK WALL

1: FIND FIVE 5/4 X 6 X 23-7/8" ROCK WALL BOARDS, AND ONE 5/4 X 6 X 23-7/8" BOTTOM ROCK WALL BOARD(1 HOLE).

2: STARTING FROM THE BOTTOM, PLACE THE BOTTOM ROCK WALL BOARD ON BOTTOM OF THE ROCK WALL SIDES, FLUSH TO THE BOTTOM OF THE ROCK WALL SIDES, AND ATTACH WITH TWO 2" WOOD SCREWS IN EACH SIDE.

3: CONTINUE UP THE ROCK WALL WITH THE ROCK WALL BOARDS, SPACING THE ROCK WALL BOARD 3-1/8" APART. FASTEN EACH BOARD WITH TWO 2" WOOD SCREWS ON EACH END.

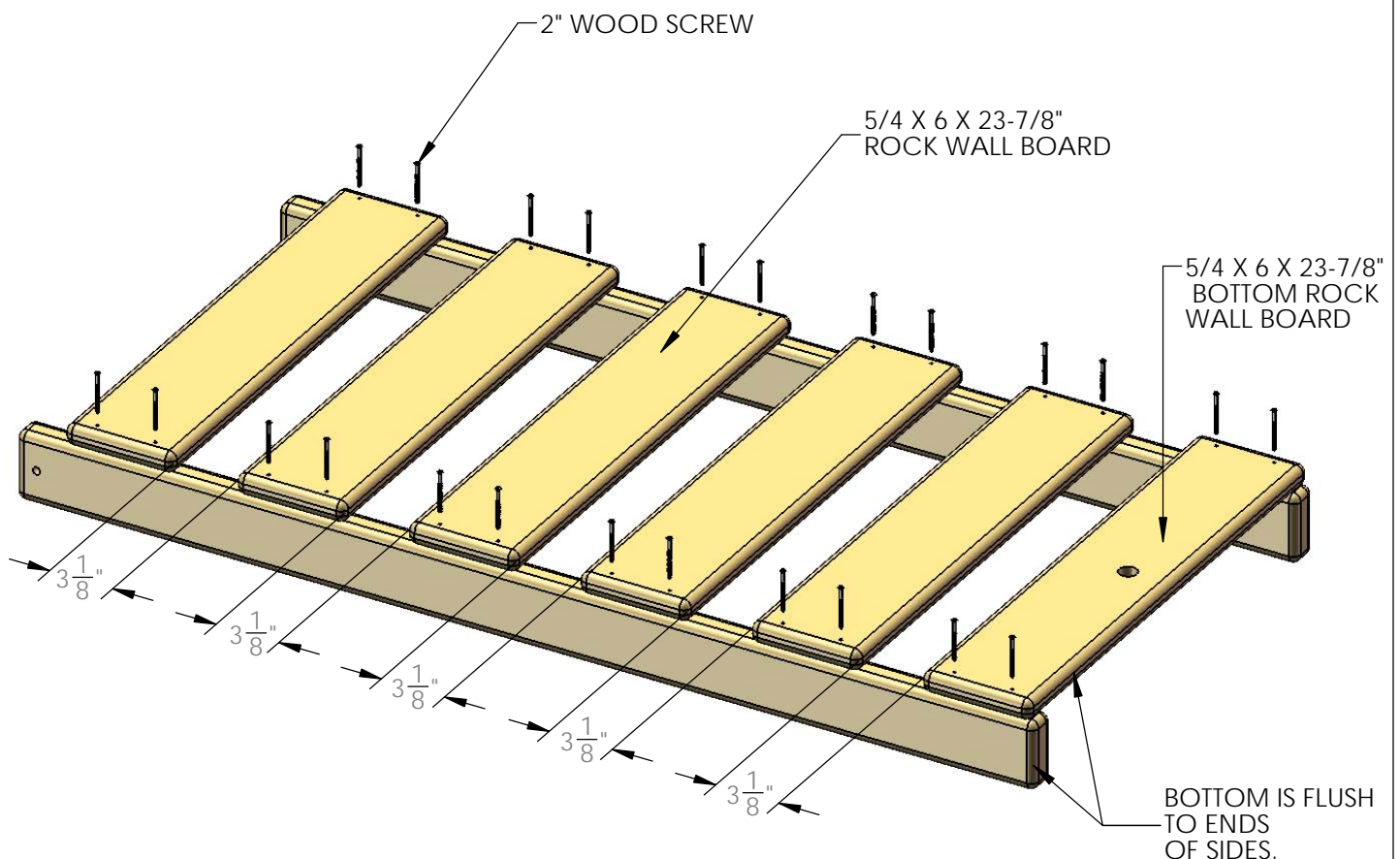

STEP 21: ROCK WALL

- 1: FIND A 5/4 X 3 X 23-7/8" ROCK WALL TOP CAP AND 5/4 X 4 X 23-7/8" ROCK WALL TOP.
- 2: PLACE THE 5/4 X 3 X 23-7/8" ROCK WALL TOP CAP ON ENDS OF THE ROCK WALL SIDES. FLUSH THE ROCK WALL BOARD TOP CAP TO TOP AND SIDE OF ROCK WALL SIDES, FASTEN THE ROCK WALL TOP CAP TO THE ROCK WALL SIDES WITH 2" WOOD SCREWS.
- 3: PLACE THE 5/4 X 4 X 23-7/8" ROCK WALL TOP ON TOP OF THE ROCK WALL SIDES AND ROCK WALL TOP CAP, FLUSH TO THE TOP OF ROCK WALL TOP CAP, FASTEN THE ROCK WALL TOP TO THE ROCK WALL SIDES AND ROCK WALL TOP CAP WITH 2" WOOD SCREWS.

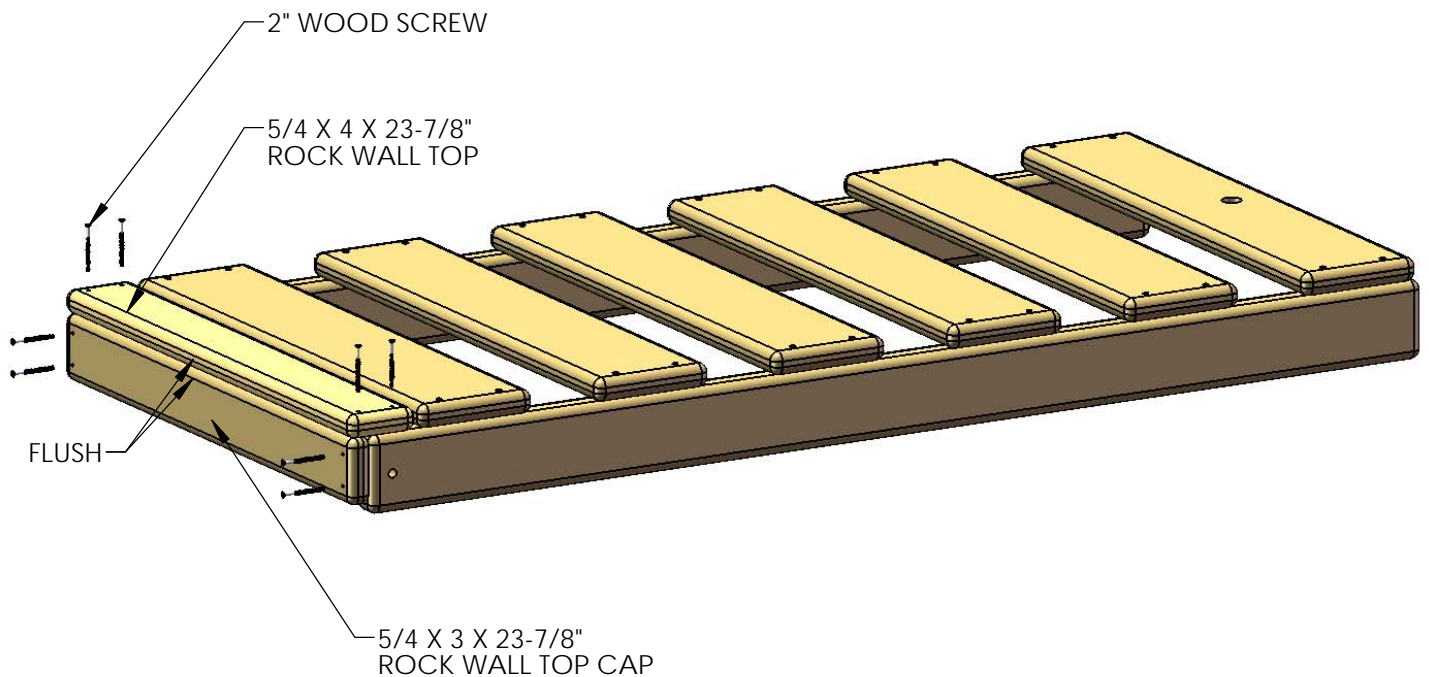

STEP 22: ROCK WALL

1: FASTEN THE 90° GREEN BRACKET TO THE ROCK WALL SIDES WITH 5/16 X 1-1/2" HEX BOLTS AND 5/16" WASHERS.

2: DO NOT FULLY TIGHTEN THE HEX BOLTS INTO THE T-NUTS AT THIS TIME.

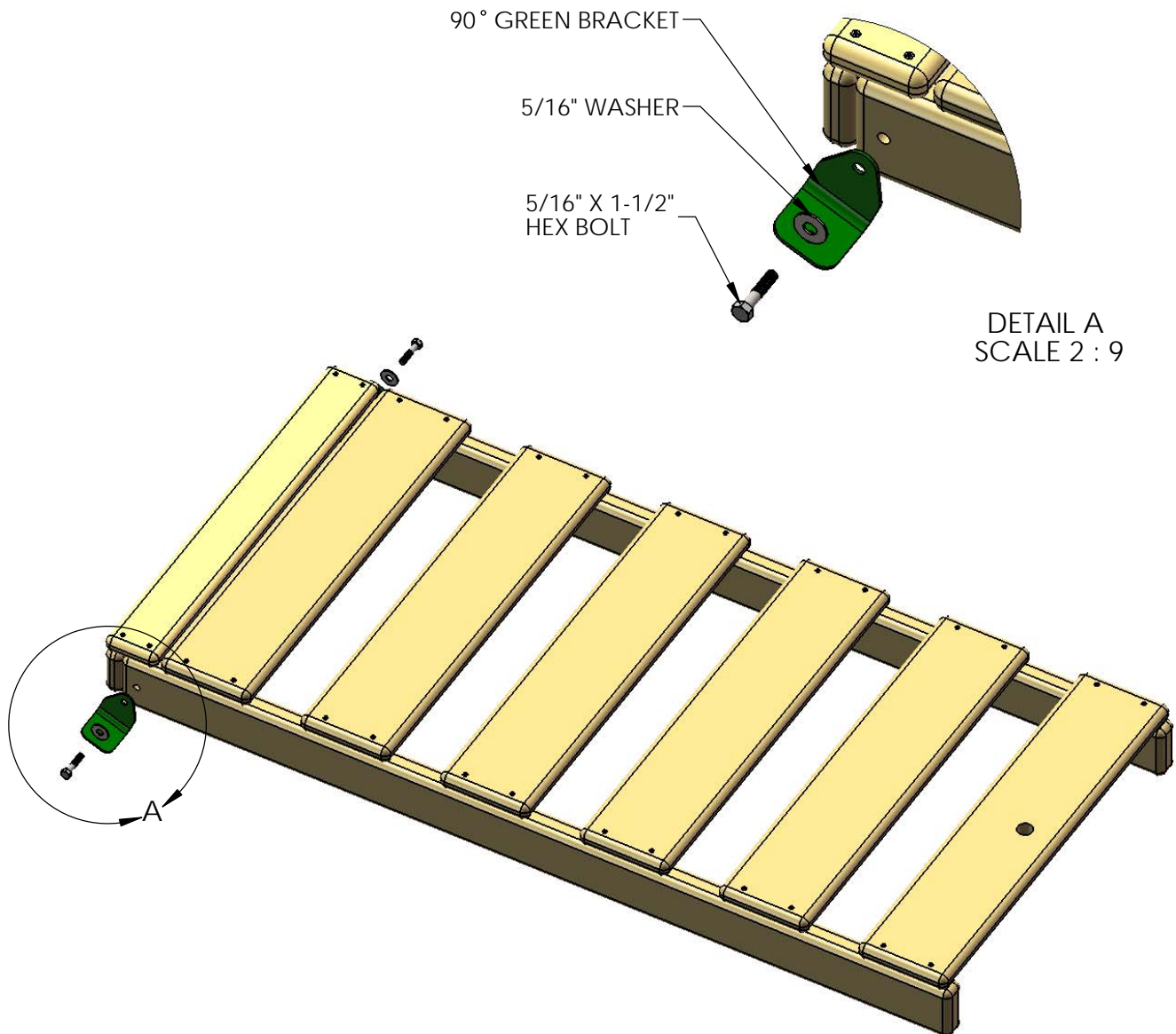

STEP 23: ROCK WALL

1: FIND FIVE ROCKS AND FIFTEEN 1-1/4" PAN HEAD SCREWS WITH WASHERS.

2: MOUNT THE ROCKS IN A STAGGERED MANNER ON THE ROCK WALL BOARDS. THREE PAN HEAD SCREWS AND WASHERS WILL SECURE EACH ROCK TO THE WALL.

NOTE: THE IMAGE SHOWN BELOW IS A GENERIC ARRANGEMENT OF ROCKS ON THE ROCK WALL. YOUR ACTUAL CONFIGURATION MAY BE DIFFERENT THAT WHAT YOU SEE BELOW. ROCKS CAN BE ARRANGED IN ANY PATTERN AS LONG AS THEY WILL ALLOW PROPER ACCESS TO THE FORT. BE CREATIVE!

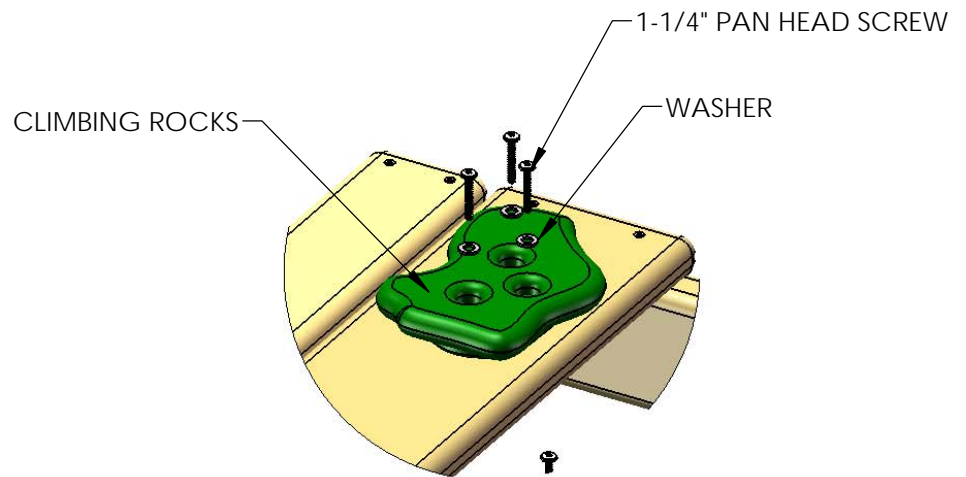

DETAIL A
SCALE 2 : 9

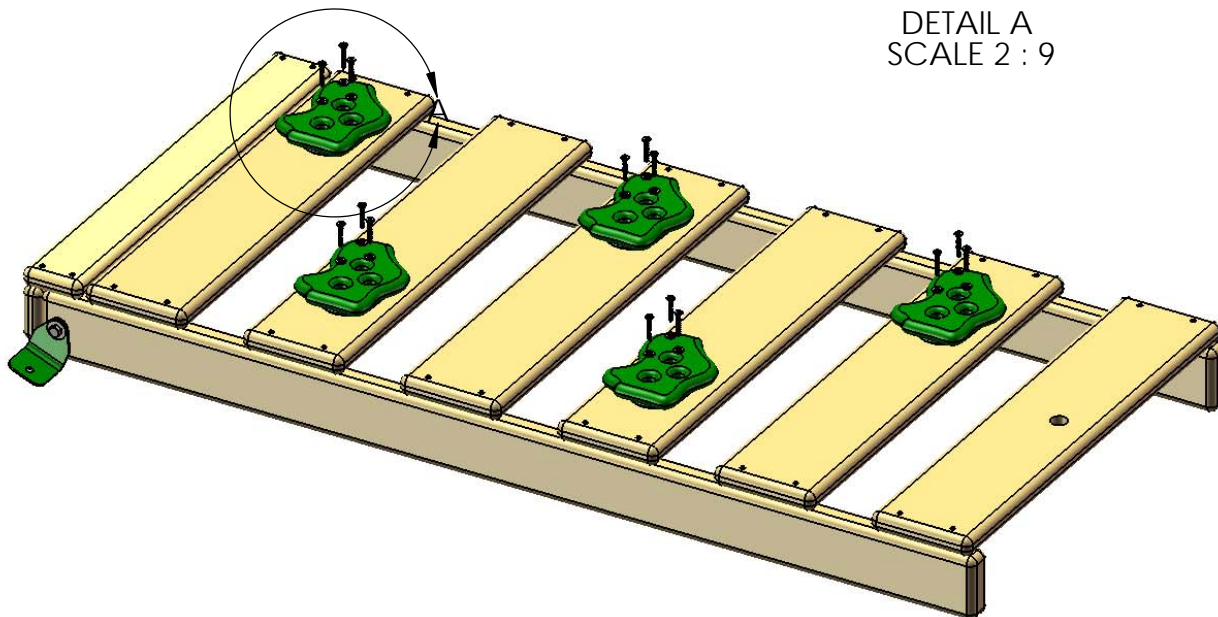

STEP 24: ROCK WALL

1: PLACE THE ROCK WALL INTO POSITION CENTERED ON THE RIGHT SIDE ON THE FORT. THE BOTTOM EDGE OF THE GREEN BRACKETS SHOULD BE 3/4" ABOVE THE BOTTOM OF THE BOTTOM PANEL BOARD. USING THE BRACKETS AS A TEMPLATE DRILL A 3/8" HOLE THROUGH THE BOTTOM PANEL BOARD.

2: FROM THE UNDERSIDE OF THE DECK INSERT A T-NUT INTO THE BACKSIDE OF THE 3/8" HOLES IN THE BOTTOM PANEL BOARD.

3: ATTACH THE ROCK WALL WITH 5/16 X 1-1/2" HEX BOLTS AND 5/16" WASHERS.

4: WHEN THE 90° BRACKETS ARE SECURE, AND THE ROCK WALL IS IN ITS FINAL POSITION; TIGHTEN THE 5/16 X 1-1/2" BOLTS ON THE ROCK WALL SIDES.

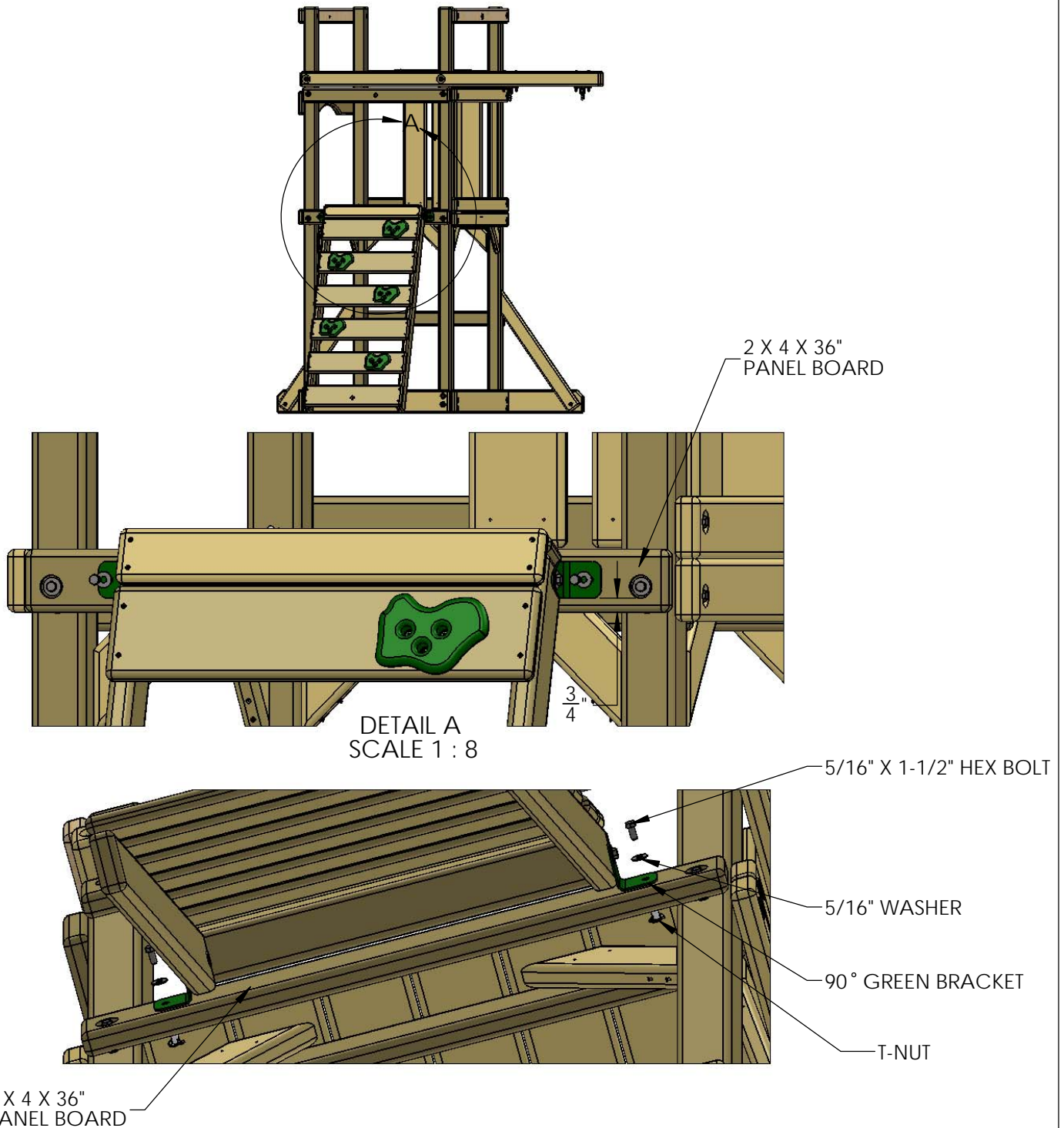

STEP 25: ATTACHING SWING LEGS TO BRACKET

- 1: PLACE THE 3 X 3 X 96" SWING LEGS FLUSH TO THE TOP OF THE SWING LEG BRACKET.
- 2: USING THE SWING LEG BRACKET AS A TEMPLATE, DRILL 1 1/64" PILOT HOLES 2-1/2" DEEP AT EACH SWING LEG BRACKET HOLE.
- 3: FASTEN THE SWING LEGS TO THE SWING LEG BRACKET WITH 3/8" X 2-1/2" LAG SCREWS AND 3/8" WASHERS.

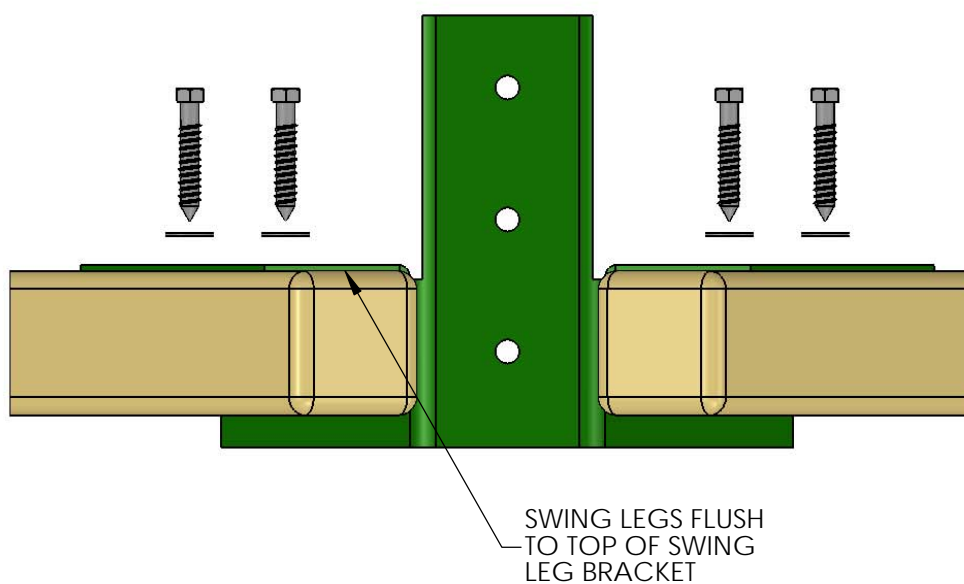
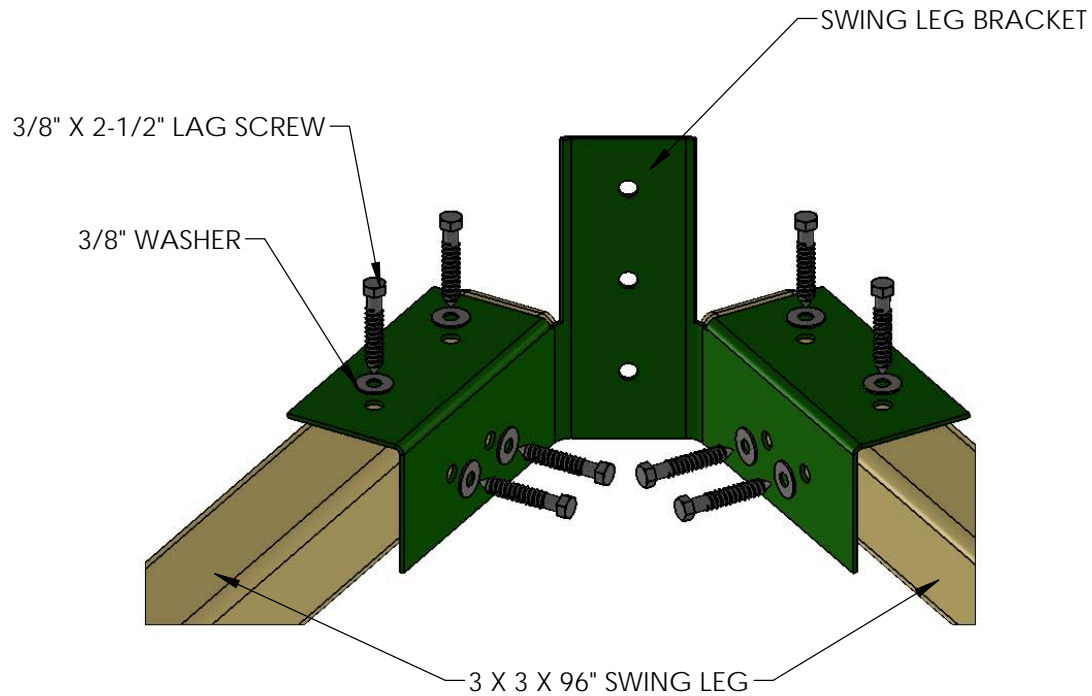

STEP 26: MOUNT SWING BEAM TO SWING BEAM LEGS

1: FASTEN THE SWING BEAM TO THE SWING BEAM BRACKET USING 3/8" X 7" CARRIAGE BOLTS WITH TORQUE WASHERS ON TOP OF THE SWING BEAM, AND 3/8" LOCK NUTS WITH 3/8" WASHERS FROM UNDERNEATH.

2: PREDRILL AN 11/64" HOLE 3" DEEP THROUGH THE MIDDLE HOLE IN THE SWING LEG BRACKET. USE A 3/8" X 3-1/2" LAG SCREW WITH 3/8" WASHER AT THE HOLE IN THE CENTER OF THE SWING LEG BRACKET.

3: PLACE A BOLT CAP OVER ANY EXPOSED THREADS.

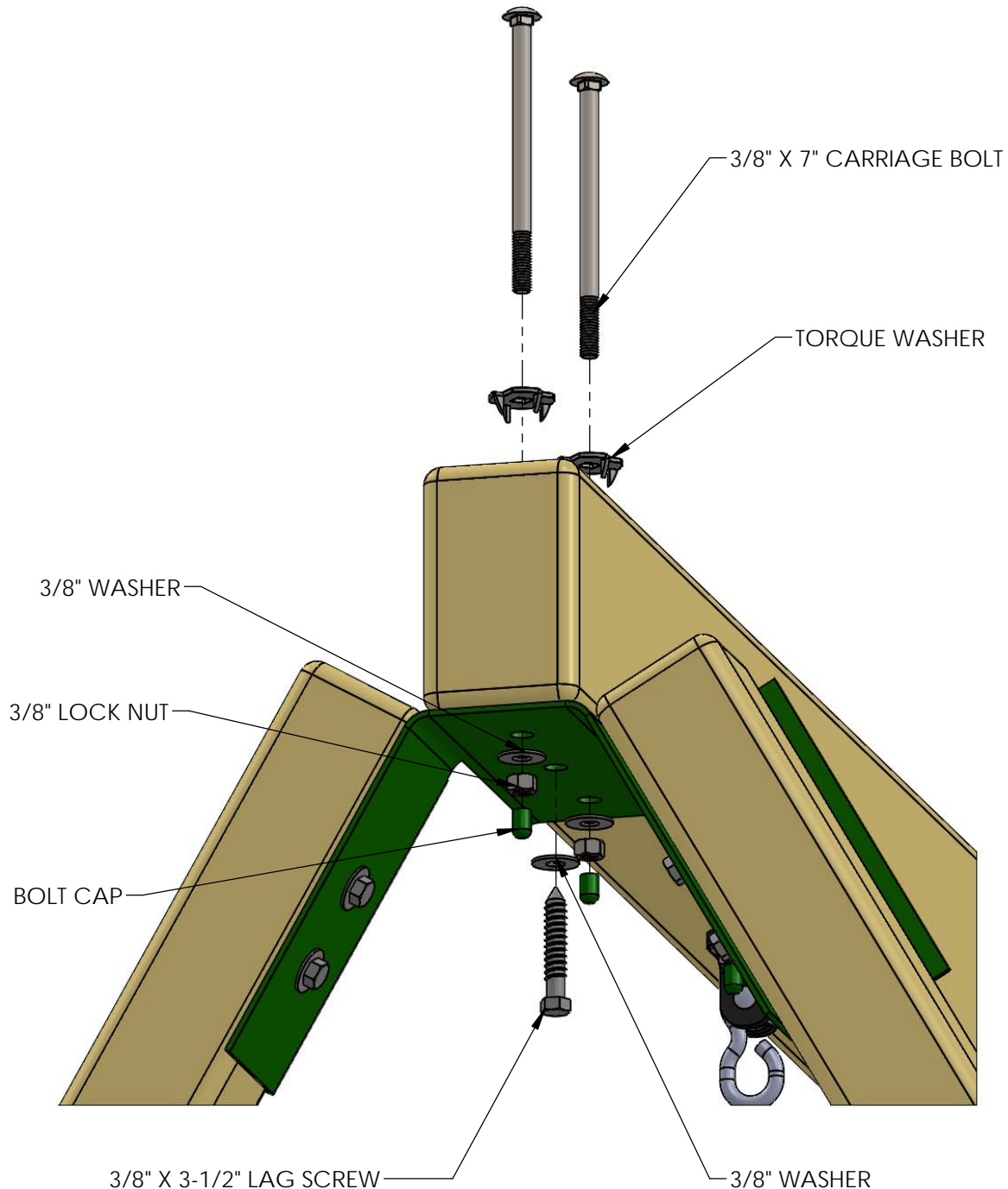

STEP 27: MOUNT SWING BEAM TO FORT

AN EXTRA PERSON IS NEEDED FOR THIS STEP.

1: HAVE ONE PERSON WALK THE SWING BEAM OUT TO THE END ON THE FORT FROM INSIDE THE FORT WHILE THE OTHER PERSON CARRIES THE LEGS.

2: LINE UP THE PILOT HOLE ON THE END OF THE SWING BEAM WITH THE MIDDLE HOLE ON THE SWING BEAM PLATE.

3: FASTEN THE SWING BEAM TO THE SWING BEAM PLATE AND SWING BEAM SUPPORT USING A 3/8" X 9" CARRIAGE BOLT WITH TORQUE WASHER ON TOP AND A 3/8" LOCK NUT WITH 3/8" WASHER ON THE BOTTOM. PLACE A GREEN BOLT CAP OVER EXPOSED THREADS AFTER SECURING.

4: PREDRILL AN 11/64" HOLE 3" DEEP THROUGH THE HOLE IN SWING BEAM PLATE. FASTEN THE SWING BEAM TO THE SWING BEAM PLATE FROM UNDERNEATH WITH A 3/8" X 3-1/2" LAG SCREW AND 3/8" WASHER.

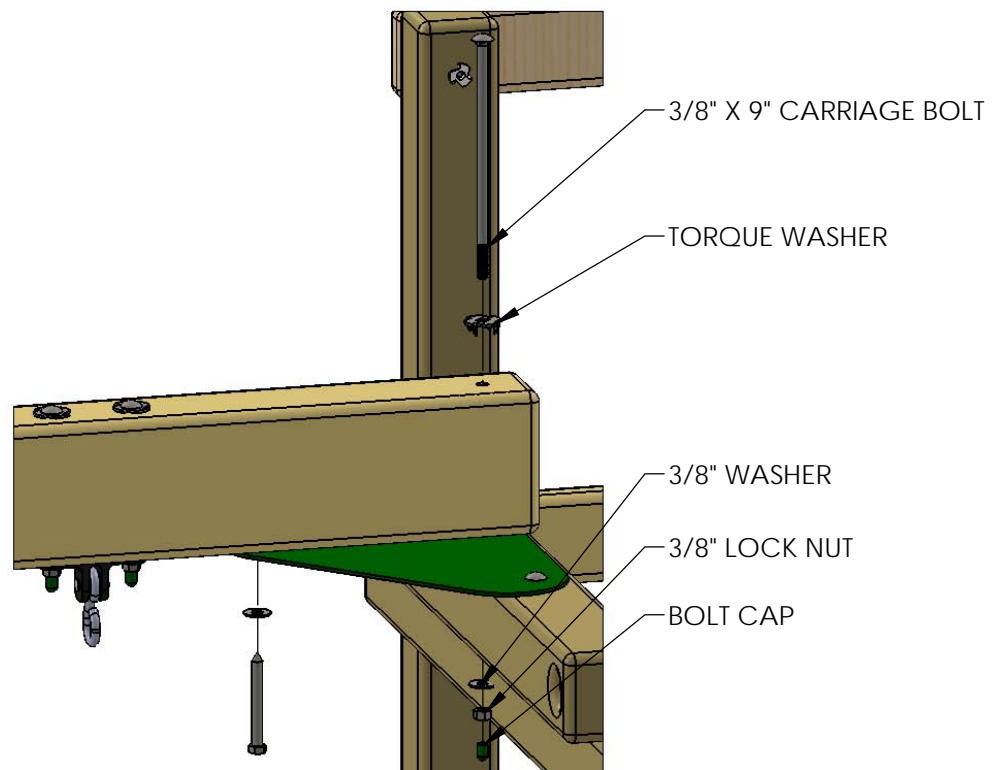
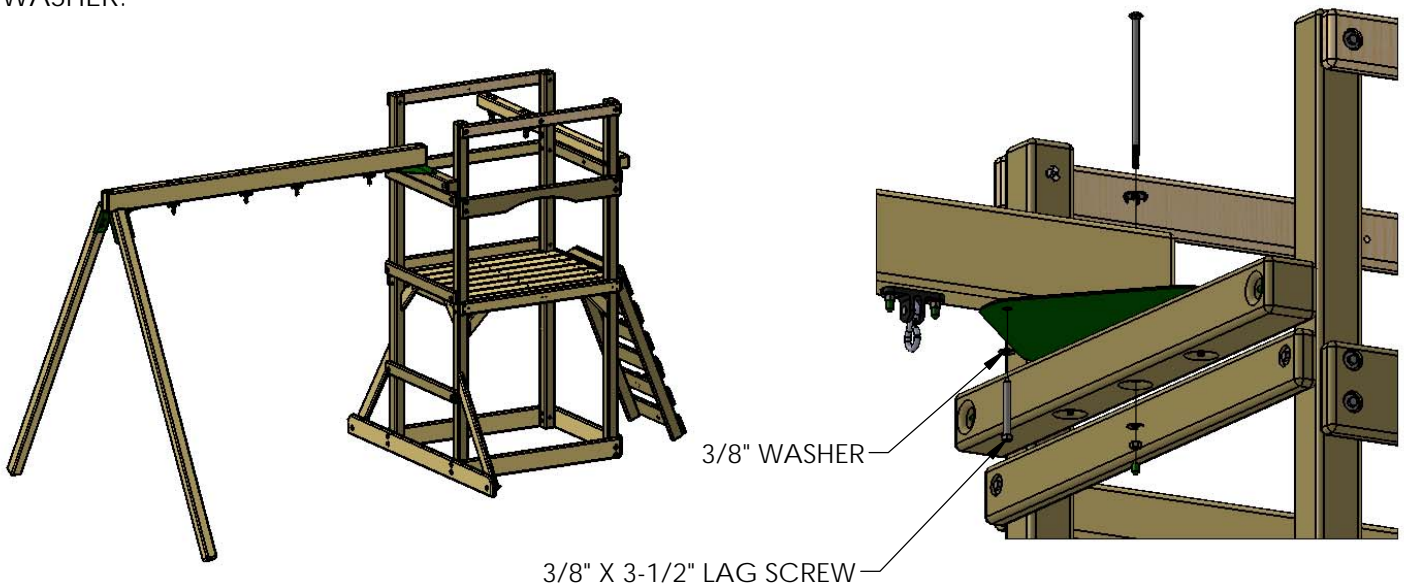

STEP 28: LEVEL SWING BEAM

1: PLACE THE LEVEL ON TOP OF THE SWING BEAM AND ADJUST THE BEAM LEGS IN OR OUT AS NEEDED TO MAKE THE SWING BEAM LEVEL.

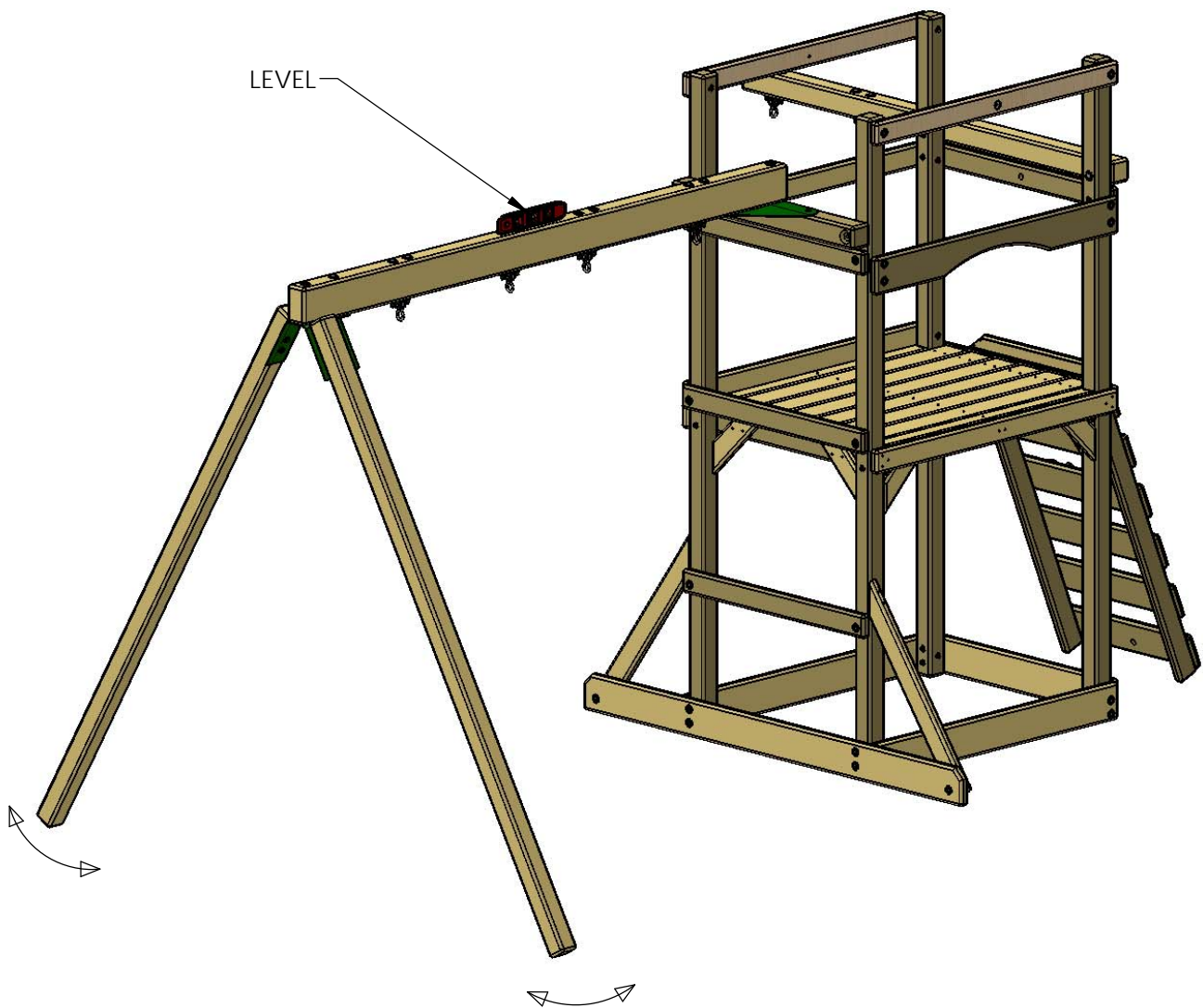

STEP 29: SWING LEG CROSS MEMBER

- 1: POSITION THE 2 X 4 X 58" CROSS MEMBER AGAINST THE SWING BEAM LEGS.
- 2: LEVEL THE CROSS MEMBER, AND MARK THROUGH THE HOLES ONTO THE LEGS. DRILL AN 11/64" HOLE AT EACH MARK 2-1/2" DEEP.
- 3: FASTEN THE CROSS MEMBER TO THE LEGS WITH 3/8 X 3-1/2" LAG SCREWS AND 3/8" WASHERS.

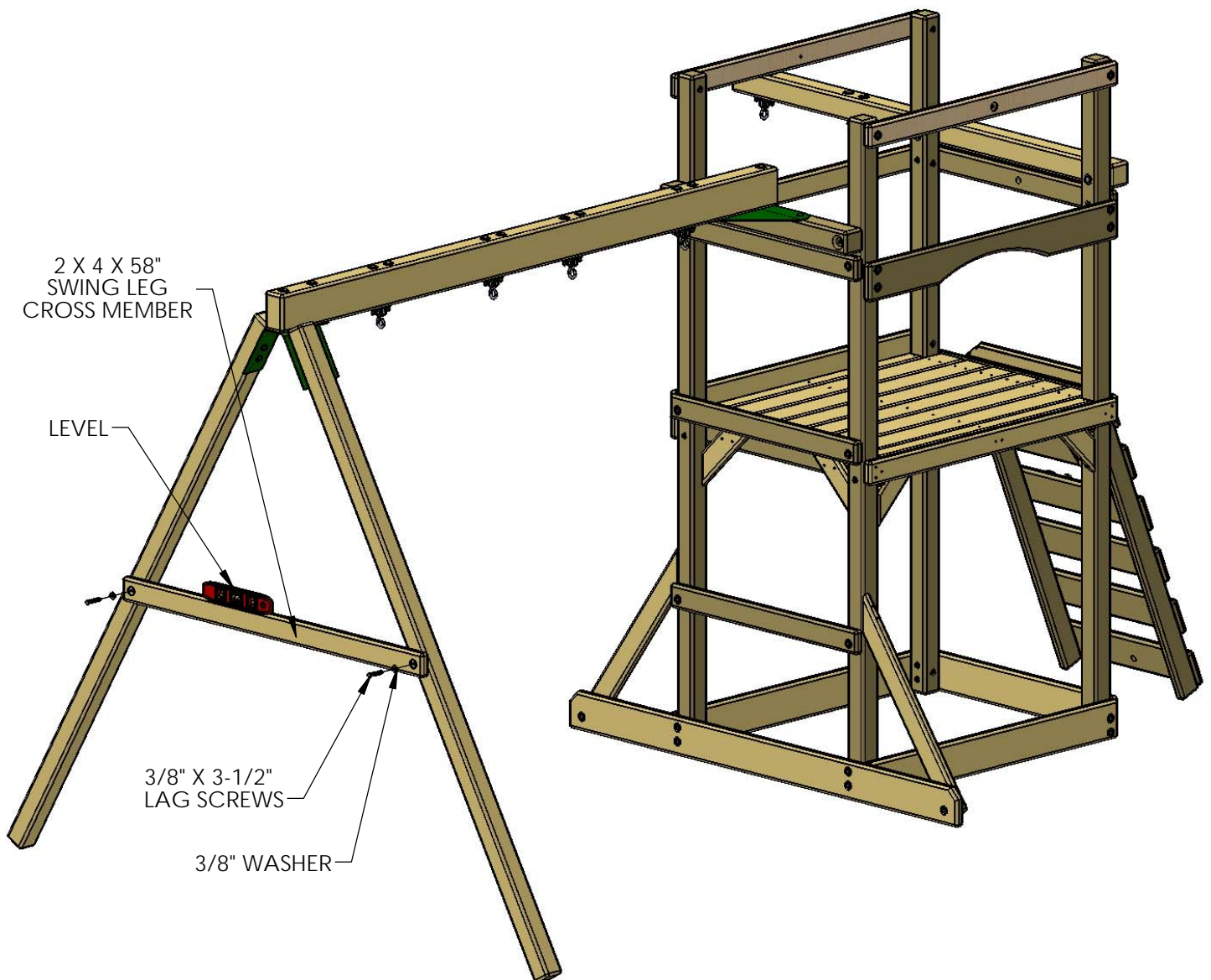

STEP 30: BOTTOM PANEL BOARDS

2: PLACE THE 2 X 4 X 14" BOTTOM PANEL BOARD ON TOP OF THE 2 X 4 FRONT FACE BOARD AND FASTEN TO THE CORNER POSTS. DRILL A 9/64" HOLE 2-1/2" DEEP THROUGH THE BOTTOM PANEL BOARD HOLE. FASTEN THE BOTTOM PANEL BOARD TO THE CORNER POST WITH A 5/16 X 3-1/2" LAG SCREW AND A 5/16" WASHERS.

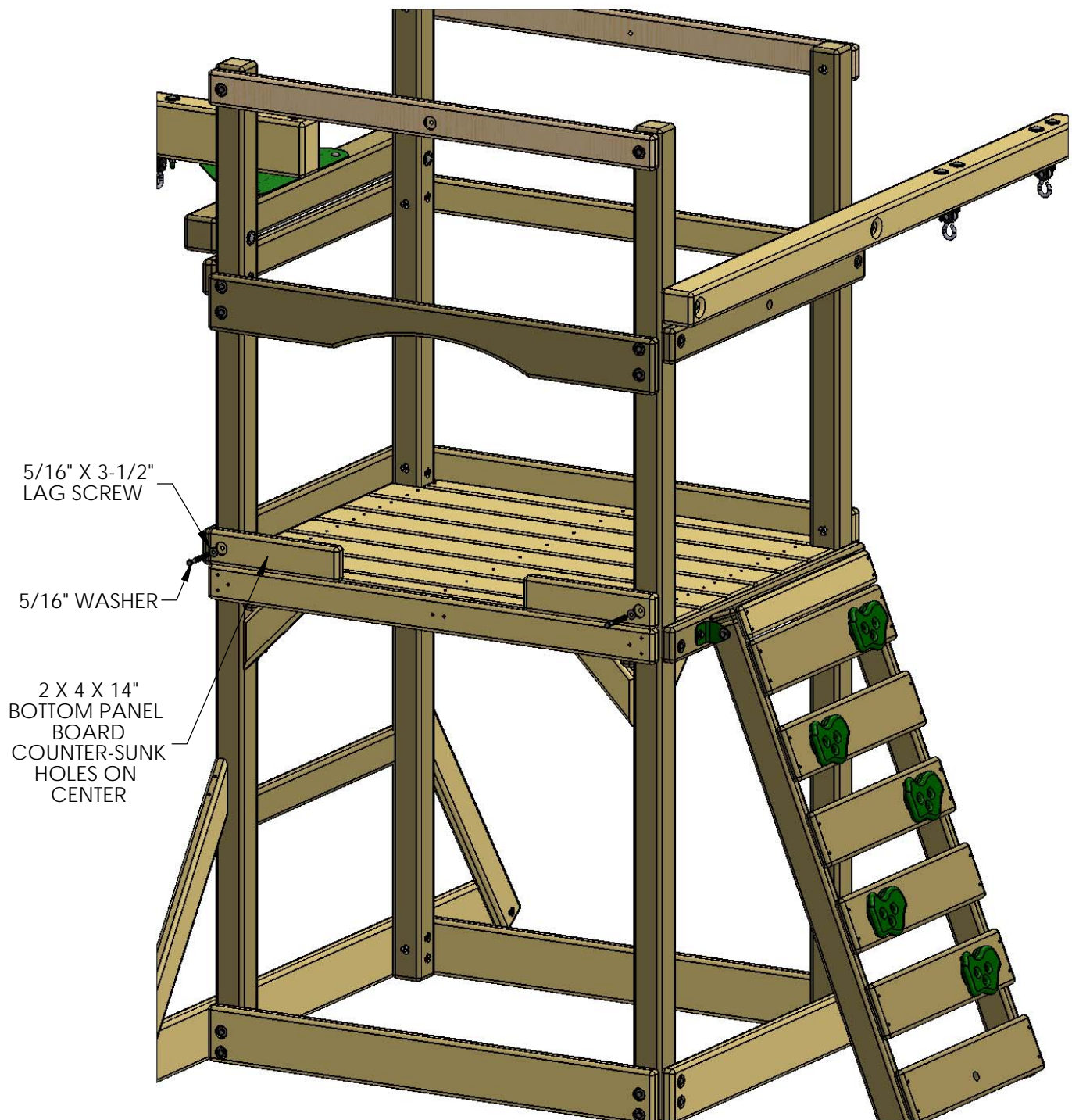

STEP 31: PANEL SLATS

- 1: FIND EIGHT 5/4 X 6 X 28" PANEL SLATS AND FOUR 5/4 X 6 X 26-3/4" PANEL SLATS.
- 2: INSTALL THE PANEL SLATS AS SHOWN BELOW. SEE DETAILS BELOW FOR MEASUREMENTS.
- 3: ATTACH THE PANEL SLATS TO THE FORT WITH 2" WOOD SCREWS IN THE PRE-DRILLED HOLES.

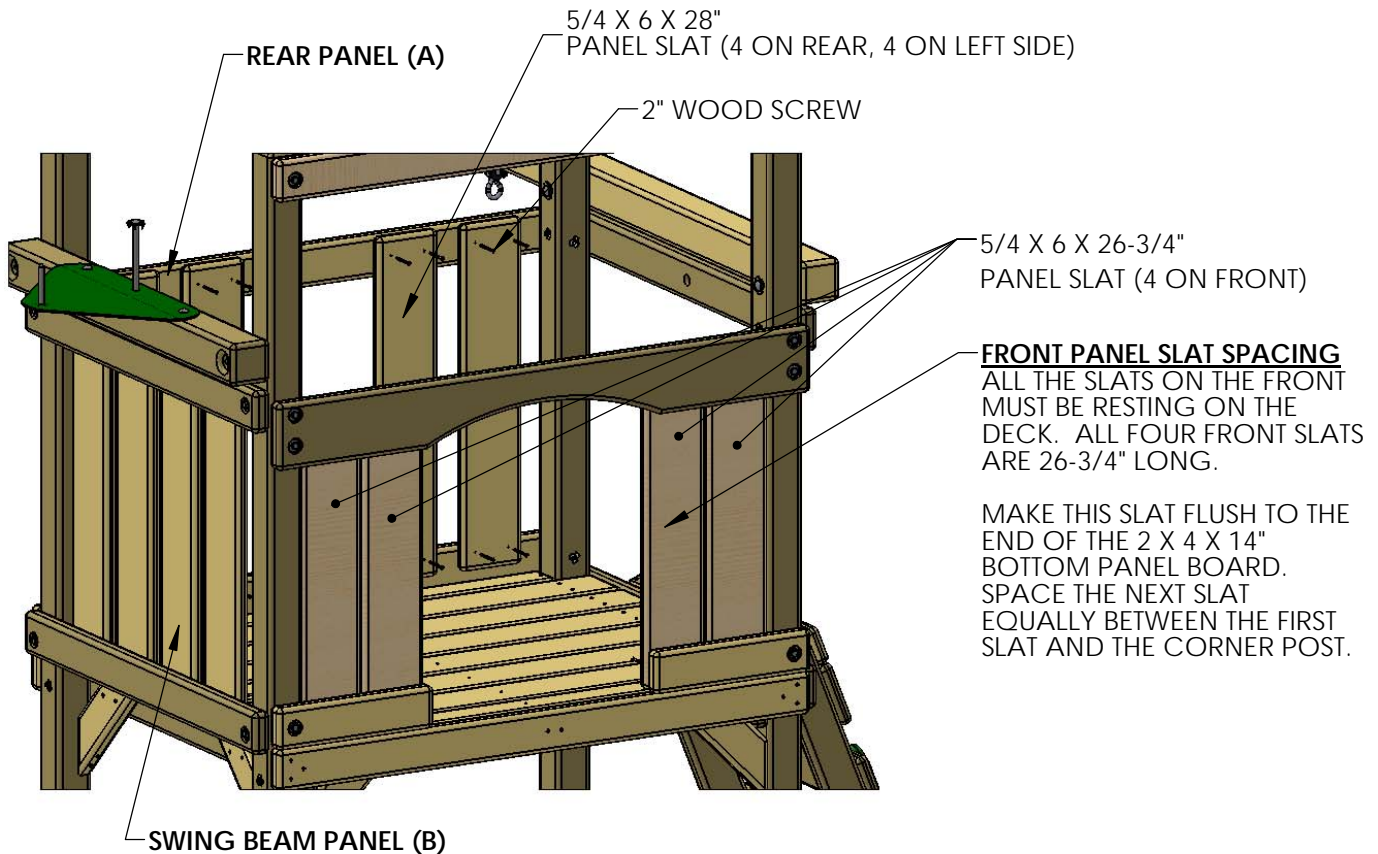

REAR PANEL SLAT SPACING (A)

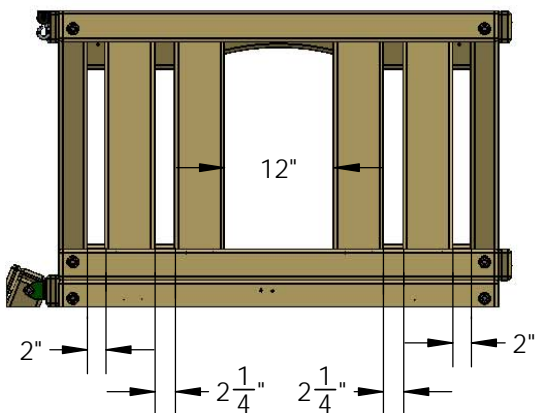

SWING BEAM PANEL (B)

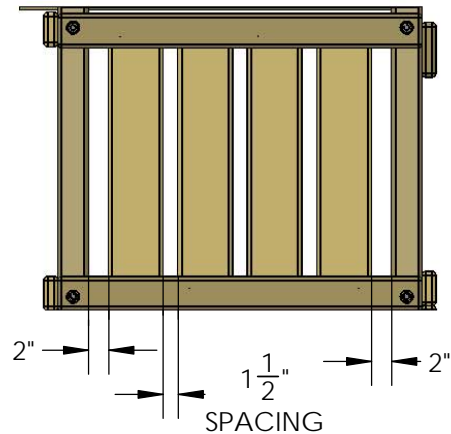

STEP 32: ATTACHING CENTER POSTS

1: THE 2 X 4 X 25" CENTER POSTS WILL SECURE TO THE TARP SUPPORTS WITH A 5/16" X 2-1/2" HEX BOLT, A 5/16" WASHER AND A T-NUT.

NOTE: MAKE SURE THE 2 X 4 X 25" CENTER POSTS ARE VERTICAL.

2: FASTEN EACH CENTER POST TO THE TARP SUPPORT WITH TWO 2-1/2" WOOD SCREWS.

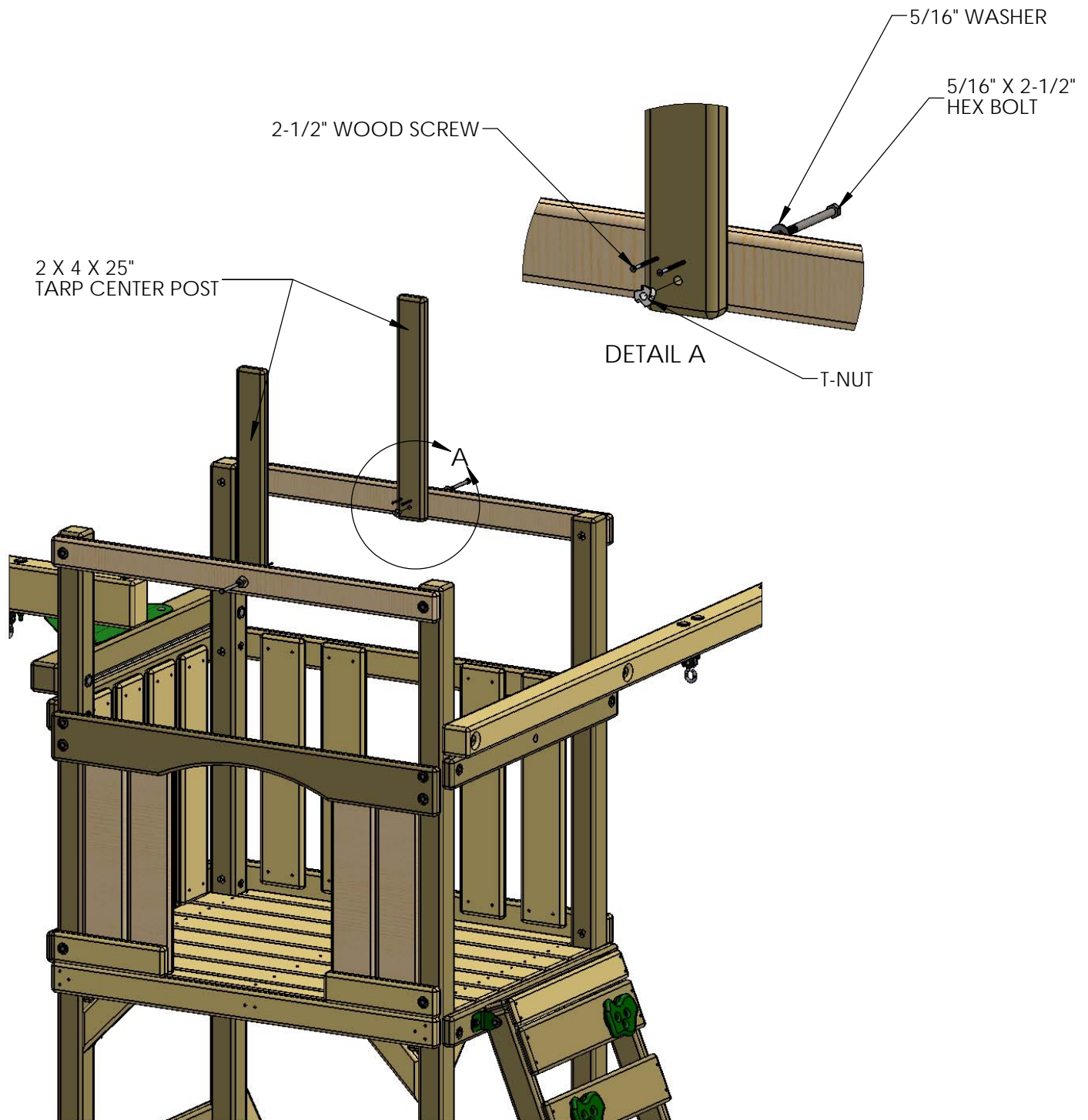

STEP 32A: WINDOW SLATS

THIS STEP WILL REQUIRE YOU TO CLIMB ONTO THE DECK. YOU WILL NEED TO INSTALL THE BOARDS ON THE INSIDE OF THE TARP SUPPORT AND ARCH FACE BOARD.

1: PLACE A 1 X 5 X 19-1/4" WALL PANEL BOARD 2 $\frac{3}{16}$ " AWAY FROM EACH OF THE FRONT CORNER POSTS. ATTACH EACH BOARD WITH #8 X 1-1/2" WOOD SCREWS.

2: PLACE A 1 X 4 X 11" WALL PANEL BOARD 3 FLUSH TO THE SIDE OF WALL PANEL BOARD 2. SPACE WALL PANEL BOARD 3 1-3/16" DOWN FROM THE TOP OF THE TARP SUPPORT. ATTACH THE BOARD WITH #8 X 1-1/2" WOOD SCREWS. REPEAT FOR THE OTHER WALL PANEL BOARD 3 ON THE OTHER SIDE.

3: PLACE A 1 X 4 X 19" WALL PANEL BOARD 1 FLUSH TO THE SIDE OF WALL PANEL BOARD 3. SPACE WALL PANEL BOARD 1 2" DOWN FROM THE TOP OF THE TARP SUPPORT. ATTACH THE BOARD WITH #8 X 1-1/2" WOOD SCREWS. REPEAT FOR THE OTHER WALL PANEL BOARD ON THE OTHER SIDE.

4: PLACE THE 1 X 4 X 9" CONNECTOR BOARD CENTERED UNDER THE TARP CENTER POST. THE MIDDLE 2 HOLES SHOULD BE AT THE TOP. FASTEN THE CONNECTOR BOARD TO THE WALL PANEL BOARD 1 BOARDS WITH FOUR #8 X 1-1/4" WOOD SCREWS.

5: SLIDE THE 1 X 4 X 19" CENTER WALL PANEL BOARD UNDER THE CONNECTOR BOARD. THE HOLES IN THE CENTER WALL PANEL BOARD SHOULD BE ON THE BOTTOM. FASTEN THE CENTER WALL PANEL BOARD TO THE CONNECTOR BOARD WITH TWO #8 X 1-1/4" WOOD SCREWS. FASTEN THE CENTER WALL PANEL BOARD AT THE BOTTOM TO THE ARCH FACE BOARD WITH #8 X 1-1/2" WOOD SCREWS.

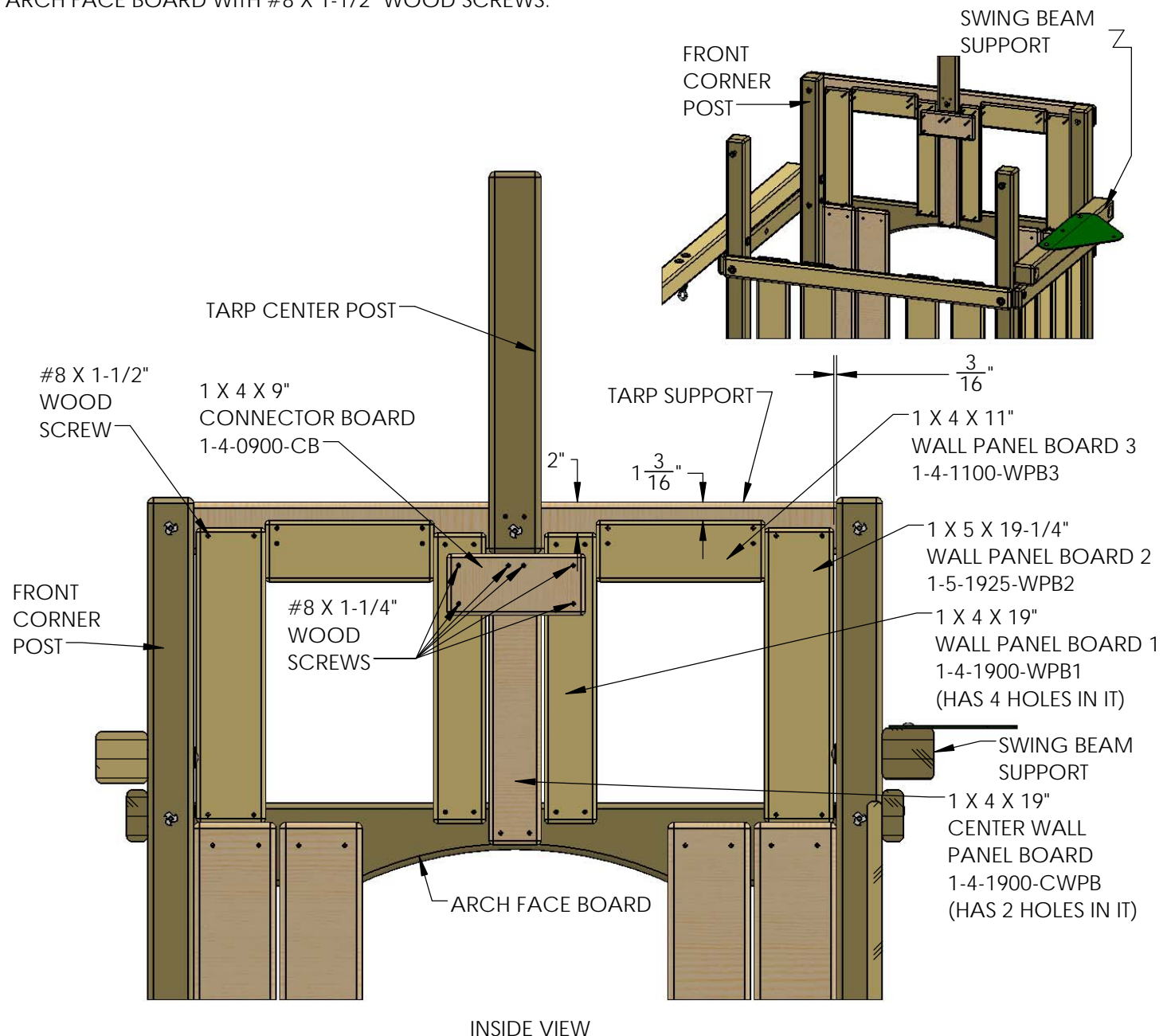

STEP 32B: WINDOWS

THE WINDOWS WILL BE INSTALLED ON THE OUTSIDE OF THE FRONT OF THE PLAY SET.

- 1: REST THE BOTTOM OF EACH WINDOW ON TOP OF THE ARCH FACE BOARD.
- 2: CENTER EACH WINDOW SIDE TO SIDE OVER THE OPENING.
- 3: ATTACH EACH WINDOW WITH FOUR #8 X 1" WOOD SCREWS.

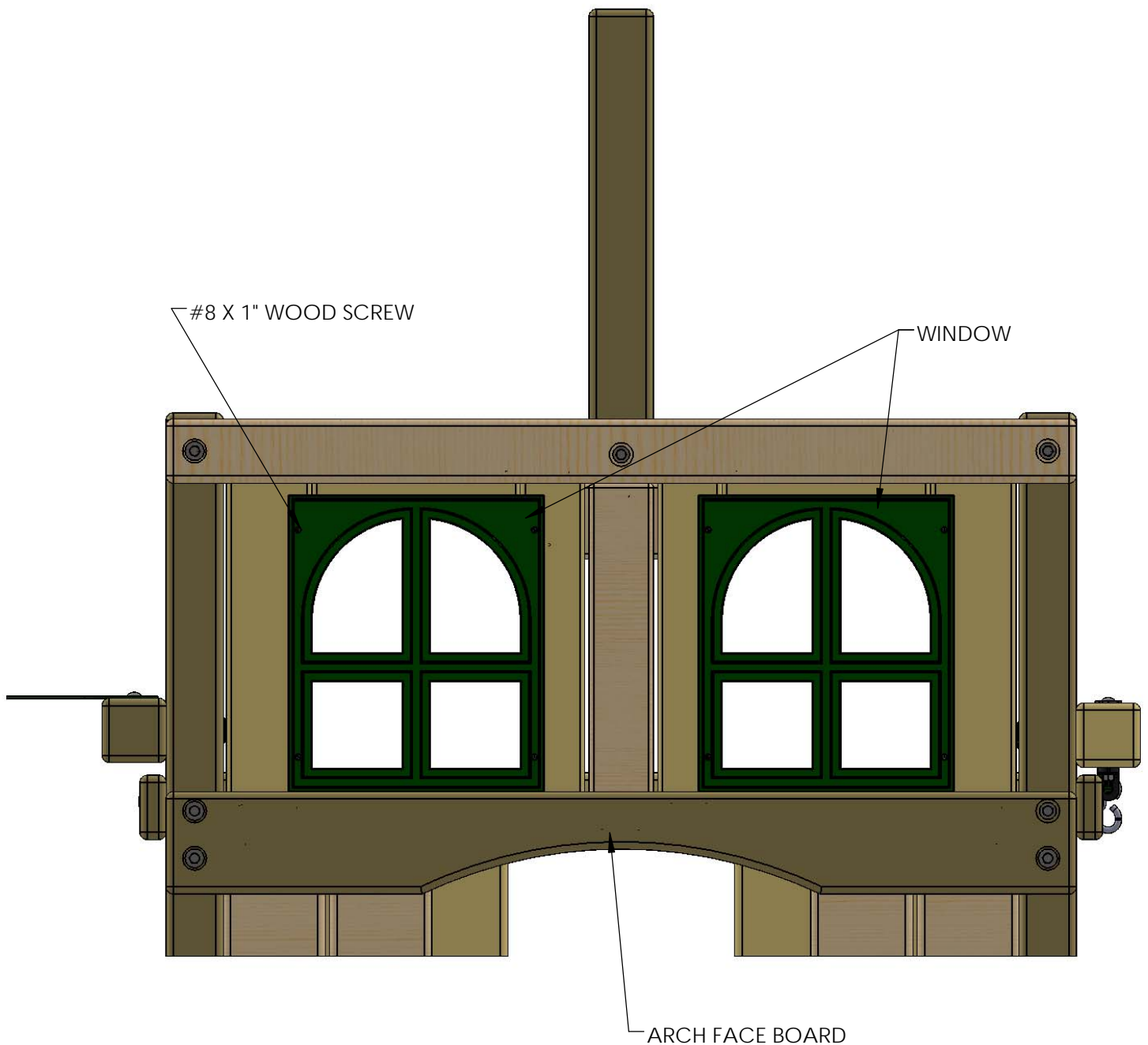

STEP 33: TARP BOARDS

1: THE 2 X 4 X 36" (CENTER) TARP BOARD WILL ATTACH TO THE TOP OF THE TARP CENTER POSTS WITH TWO 2-1/2" WOOD SCREWS PER SIDE.

2: THE TWO 2 X 4 X 36" TARP BOARDS WILL ATTACH TO THE TOP OF THE CORNER POSTS WITH TWO 2-1/2" WOOD SCREWS PER SIDE.

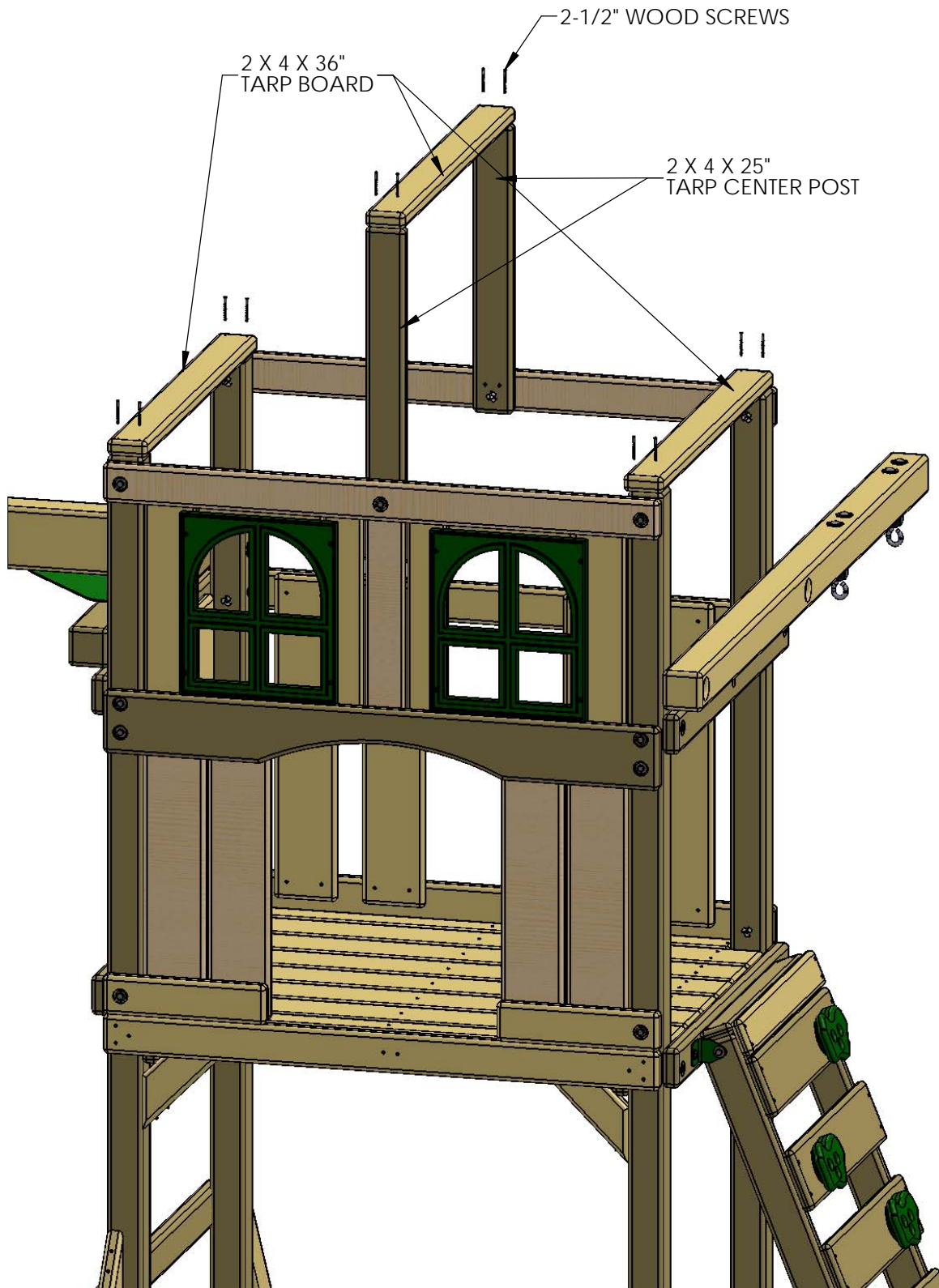

STEP 34: SUN

1: PLACE THE WOOD SUN ON TOP OF THE TARP SUPPORTS AND LEAN IT AGAINST THE TARP CENTER POST, MAKE SURE IT IS CENTERED AND SECURE WITH TWO #8 X 2-1/2" WOOD SCREWS. REPEAT ON THE BACK SIDE OF THE FORT.

2: PLACE THE PLASTIC SUN ON TOP OF THE FRONT SUN AND SECURE WITH TWO #8 X 1-1/4" WOOD SCREWS.

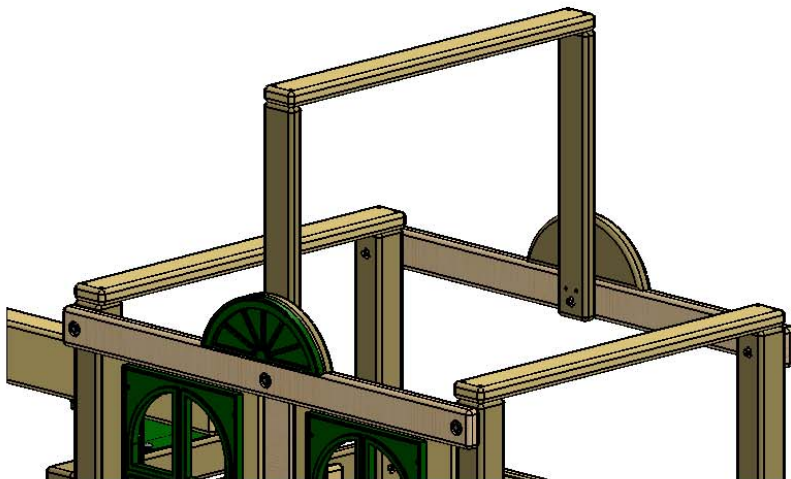
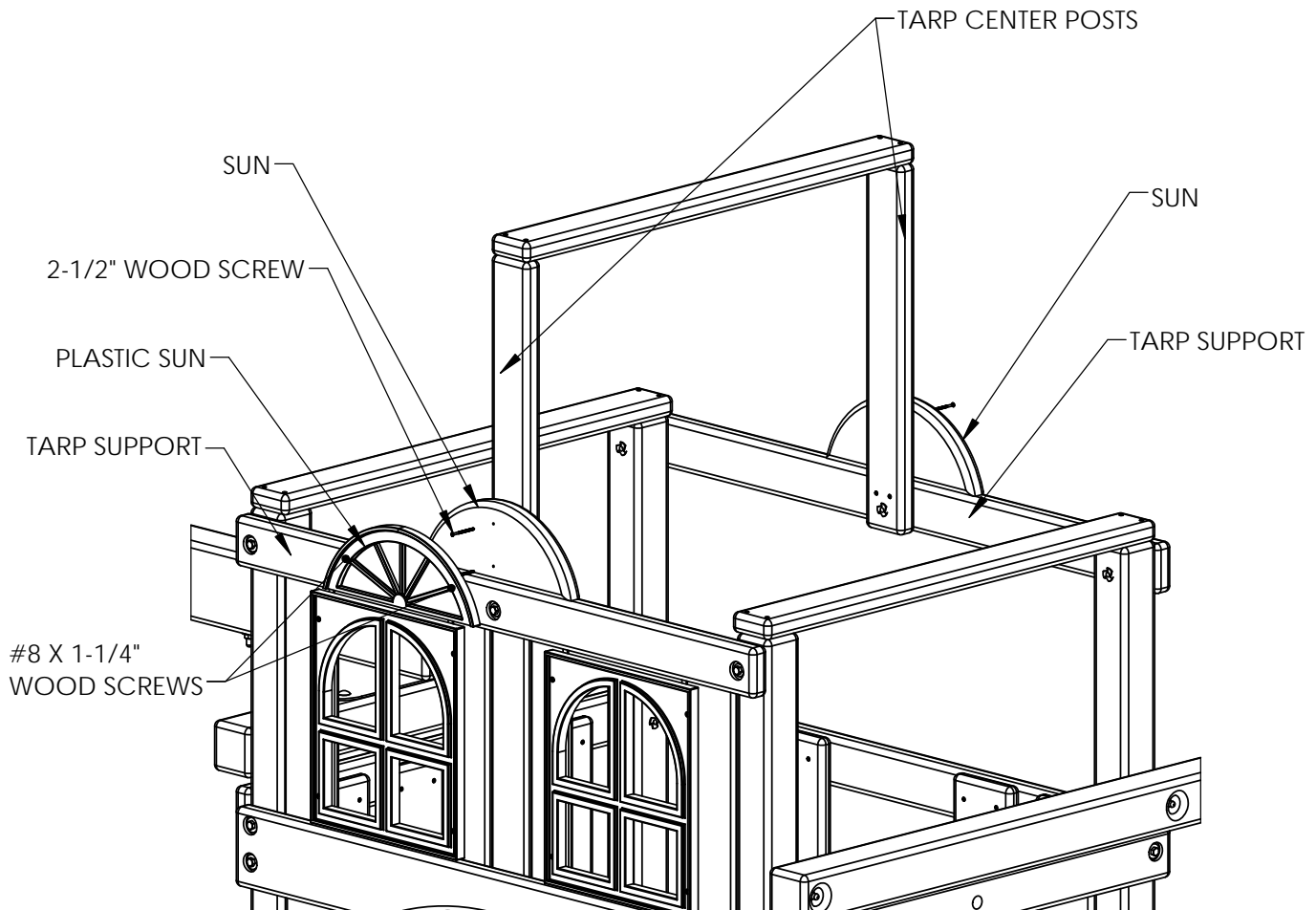

STEP 35: TARP

1: PLACE THE TARP ACROSS THE TARP BOARDS WITH THE HEMS ON THE INSIDE.

2: FASTEN THE OUTSIDE CORNERS OF THE TARP TO THE SIDE OF THE TARP BOARD FIRST. ATTACH THE GROMMETS IN THE TARP TO THE TARP BOARD WITH #14 X 1-1/4" PAN HEAD SCREWS WITH 1/4" WASHERS. REPEAT FOR OTHER SIDE. (NOTE IF YOU WISH YOU MAY PREDRILL HOLES FOR THE PAN HEAD SCREWS WITH A 1/8" DRILL BIT.)

3: NOW FOLD THE FLAP UNDER THE TARP BOARD AND FASTEN THE GROMMETS UNDER THE TARP BOARD WITH #14 X 1-1/4" PAN HEAD SCREWS WITH 1/4" WASHERS. REPEAT FOR OTHER SIDE. (NOTE IF YOU WISH YOU MAY PREDRILL HOLES FOR THE PAN HEAD SCREWS WITH A 1/8" DRILL BIT.)

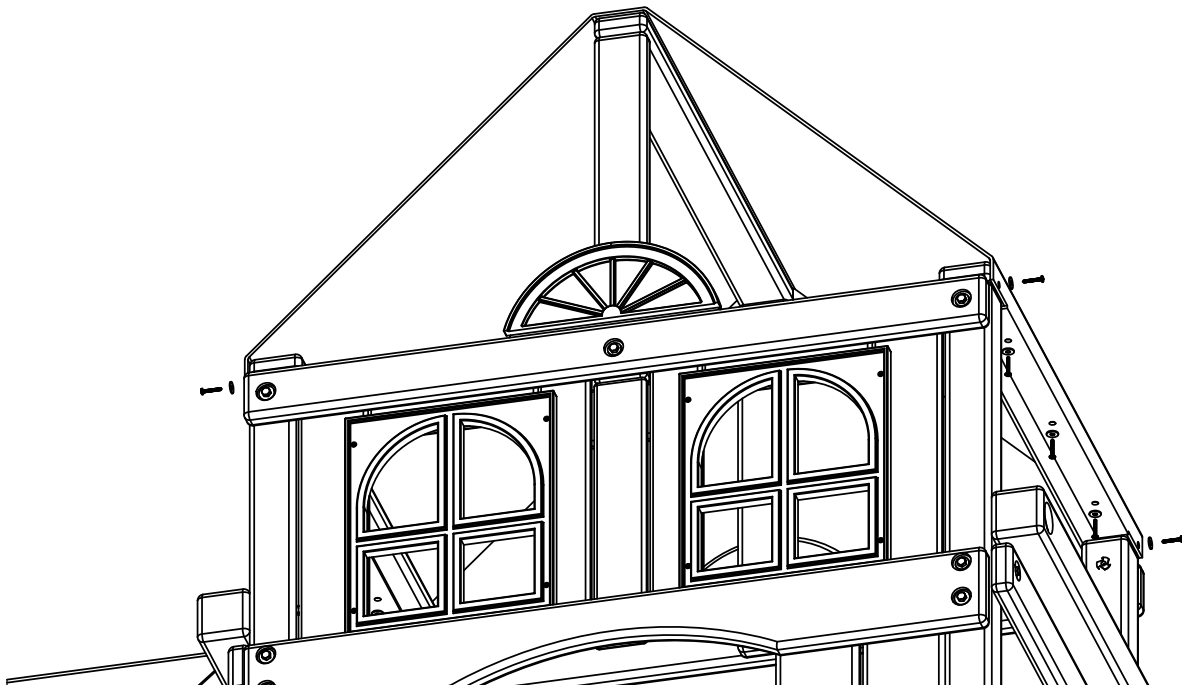
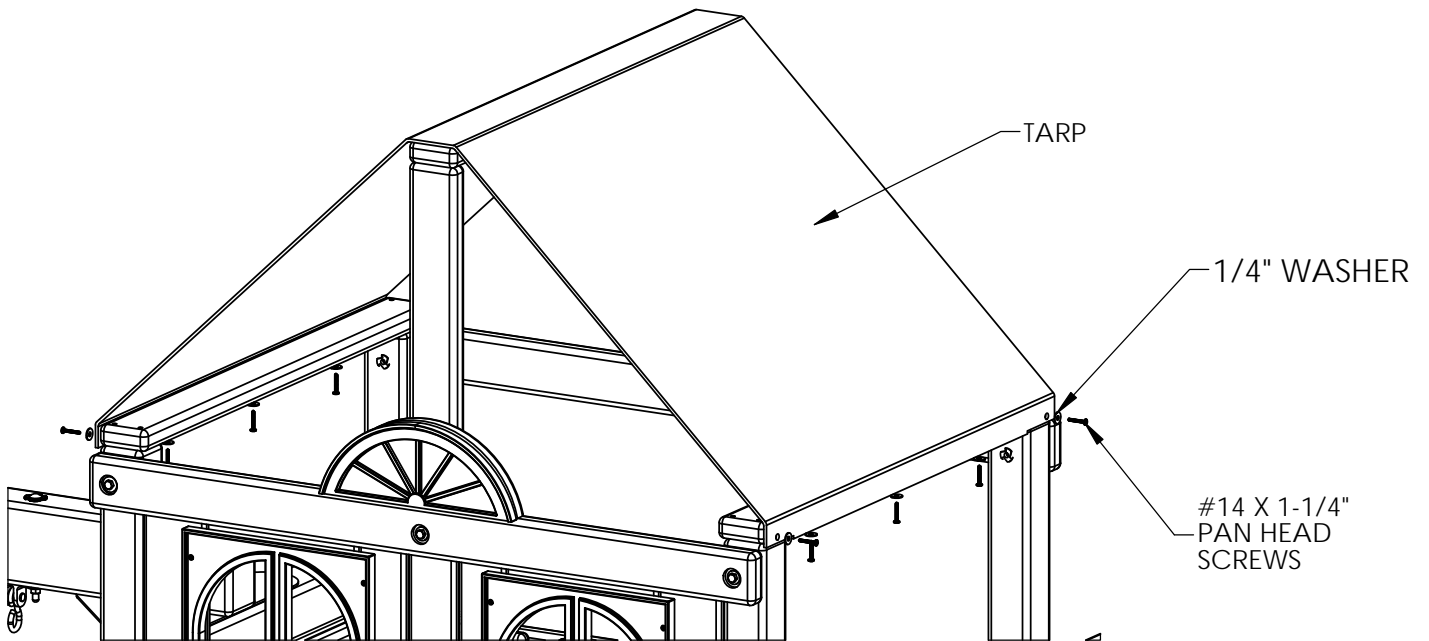

STEP 36: ROOF PEAK SUPPORT

1: PLACE THE ROOF PEAK SUPPORT ON TOP OF THE FRONT TARP CENTER POSTS AND FLUSH WITH TOP TARP BOARD , MAKE SURE IT IS CENTERED AND SECURE WITH TWO #8 X 2" WOOD SCREWS.

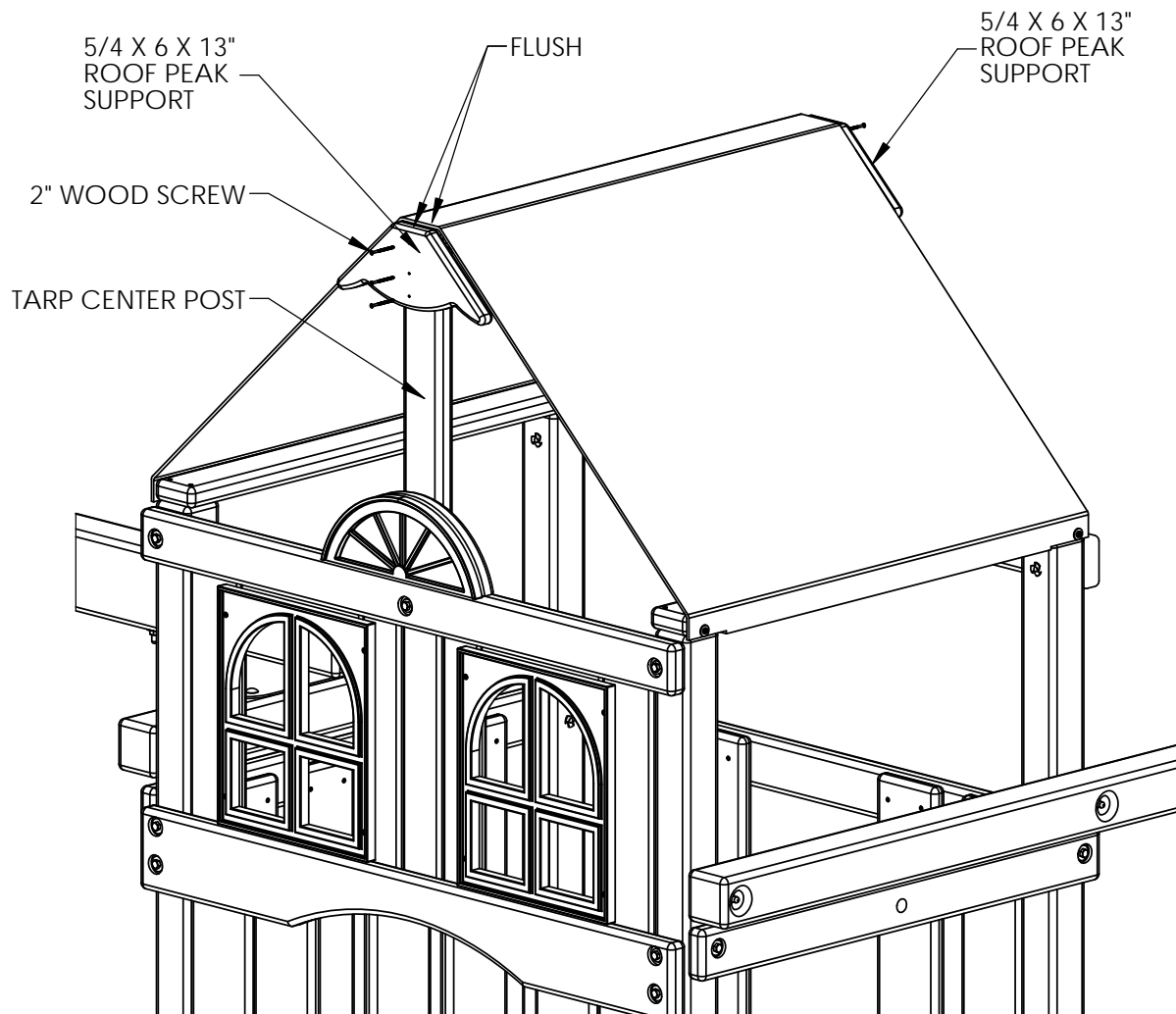

STEP 37: INSTALLING THE SLIDE

1: PLACE THE SLIDE IN THE OPENING AT THE FRONT OF THE FORT. LAY THE SLIDE ON THE DECK WITH THE LIP EXTENDING ONTO THE DECK.

2: YOU MAY PREDRILL 1/8" HOLES THROUGH THE CENTER OF EACH DIMPLE IN THE TOP OF THE SLIDE BEFORE INSTALLING THE SCREWS.

2: ATTACH THE SLIDE TO THE DECK WITH #14 X 1-1/4" TRUSS HEAD SCREWS INCLUDED WITH THE SLIDE. ***DO NOT OVER TIGHTEN***.

NOTE: ONCE INSTALLED DO NOT LIFT THE SLIDE.

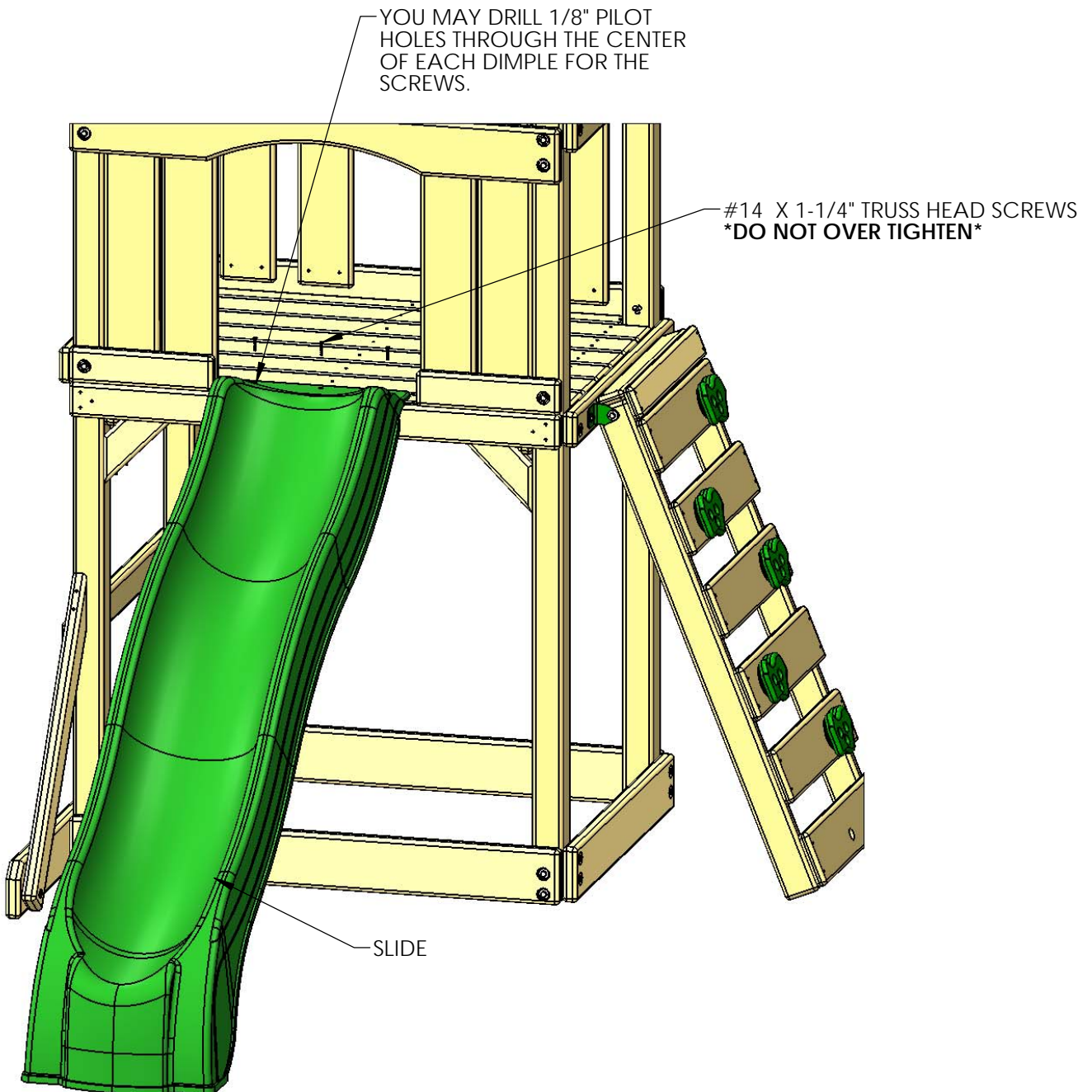

STEP 38: CLIMBING ROPE

1: THREAD ONE END OF THE 10' ROPE THROUGH THE HOLE ABOVE THE ROCK WALL. TIE SECURE KNOT ON THE INSIDE OF THE TOP PANEL BOARD. ADD KNOTS IN ROPE TO AID IN CLIMBING. SET KNOTS ACCORDING TO YOUR CHILD'S NEEDS. 2-3 KNOTS SHOULD BE SUFFICIENT.

2: THREAD THE OTHER END OF THE ROPE THROUGH THE HOLE IN THE BOTTOM ROCK WALL BOARD. PULL THE ROPE TIGHT AND TIE A SECURE KNOT BEHIND THE BOTTOM ROCK WALL BOARD.

3 : ATTEMPT TO WRAP THE ROPE AROUND YOUR HAND. IF THE ROPE WRAPS AROUND YOUR HAND IT IS TOO LOOSE. UNTIE THE TOP KNOT AND RETIE THE ROPE UNTIL IT NO LONGER WRAPS AROUND YOUR HAND.

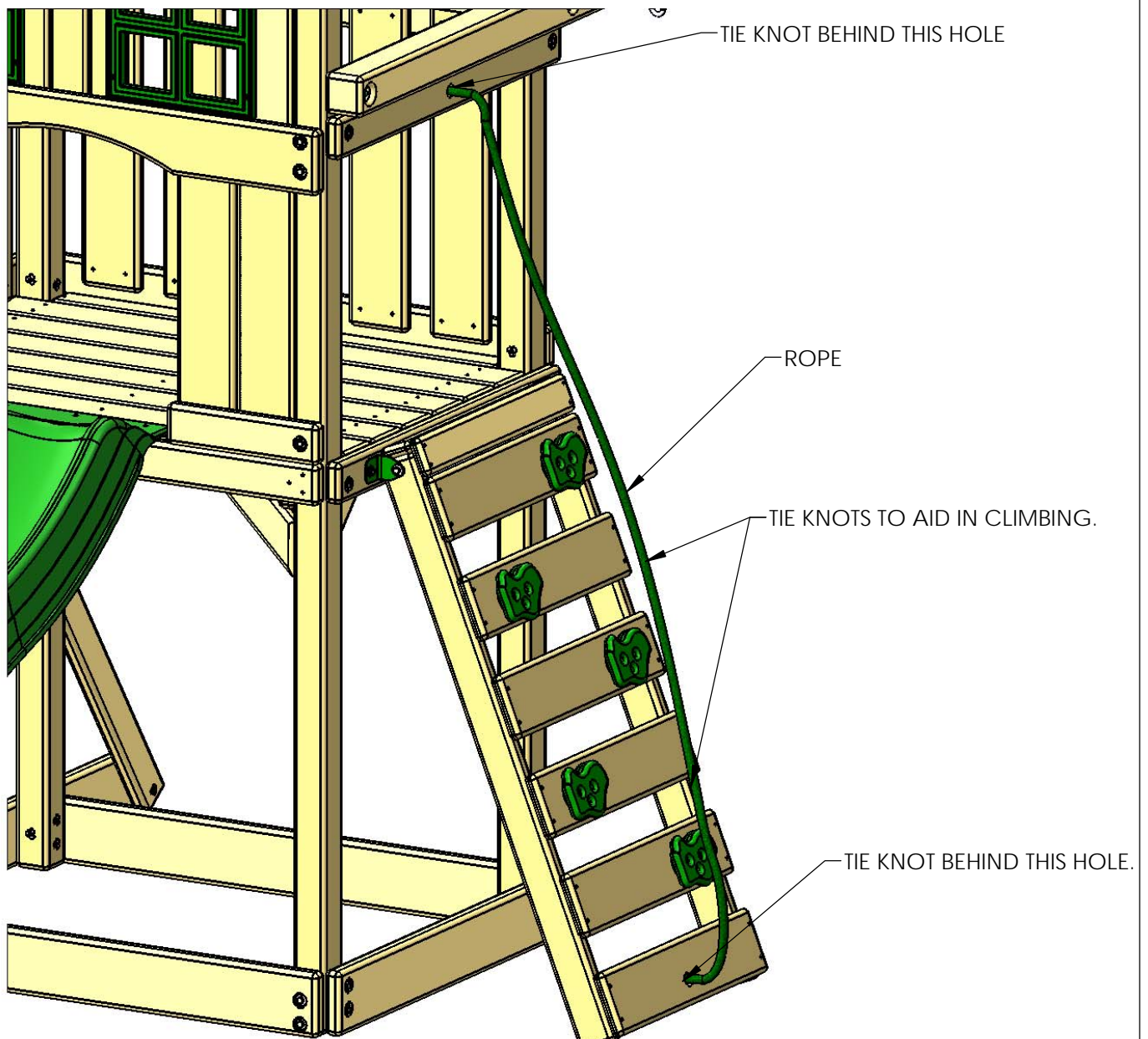

STEP 39: TIC TAC TOE ASSEMBLY

- 1: LOCATE THE 5/4 X 3 X 17-1/2" TIC TAC TOE MOUNTS.
- 2: FASTEN THE TIC TAC TOE MOUNTS TO THE GREEN TIC TAC TOE BRACKETS WITH THE SHORT SCREWS PROVIDED IN THE TIC TAC TOE BOX.
- 3: ASSEMBLE THE TIC TAC TOE ACCORDING TO THE INSTRUCTIONS IN THE BOX.

IGNORE STEPS 6 AND 7 IN THE INSTRUCTIONS.

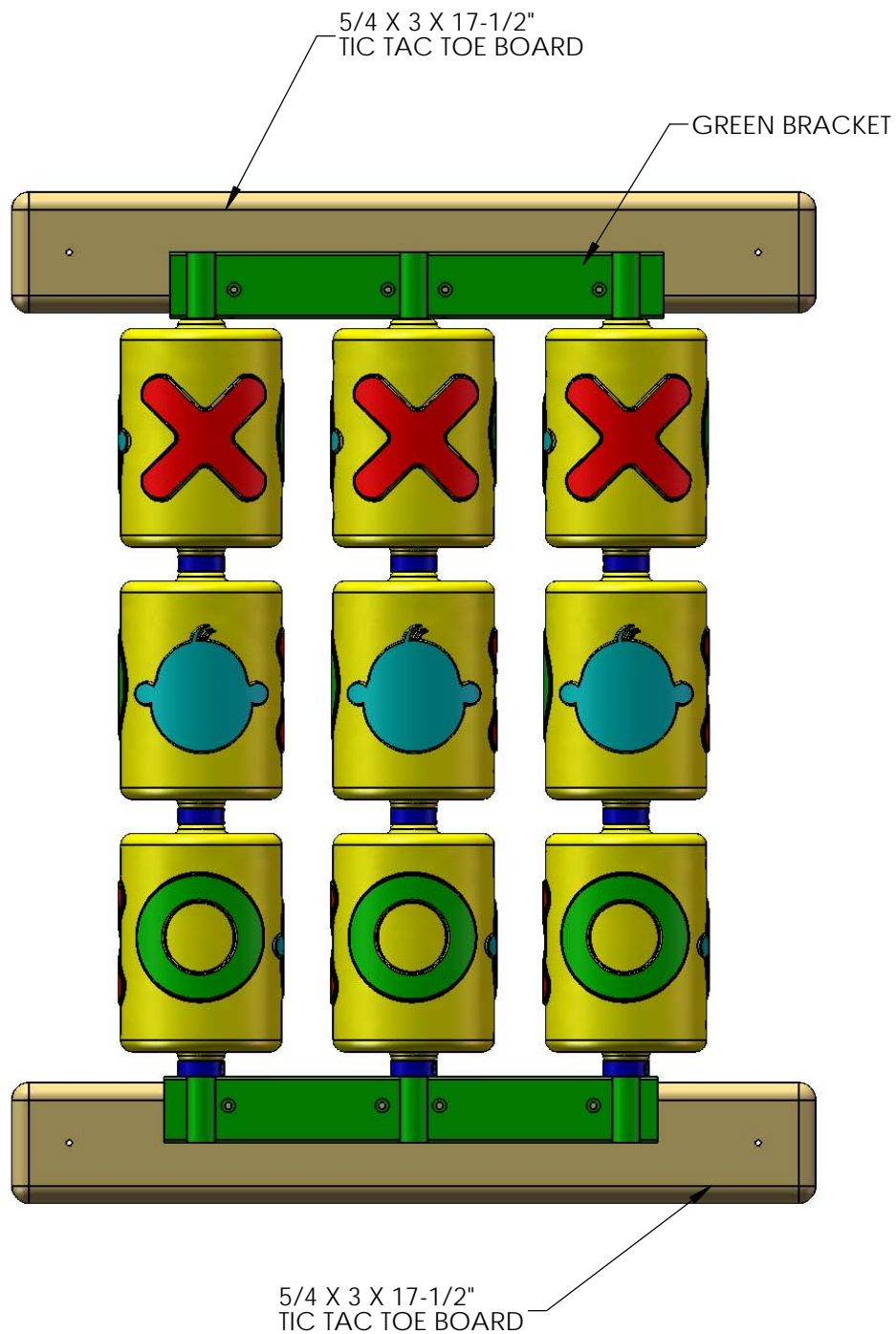

STEP 40: MOUNTING TIC TAC TOE PANEL

1: PLACE THE TIC TAC TOE PANEL ASSEMBLY FROM THE PREVIOUS STEP ONTO THE BACK WALL. THE LOWER TIC TAC TOE MOUNT BOARD SHOULD BE 4" ABOVE THE DECK.

2: ATTACH EACH TIC TAC TOE MOUNT TO THE PANEL SLATS WITH #8 X 1-3/4" WOOD SCREWS.

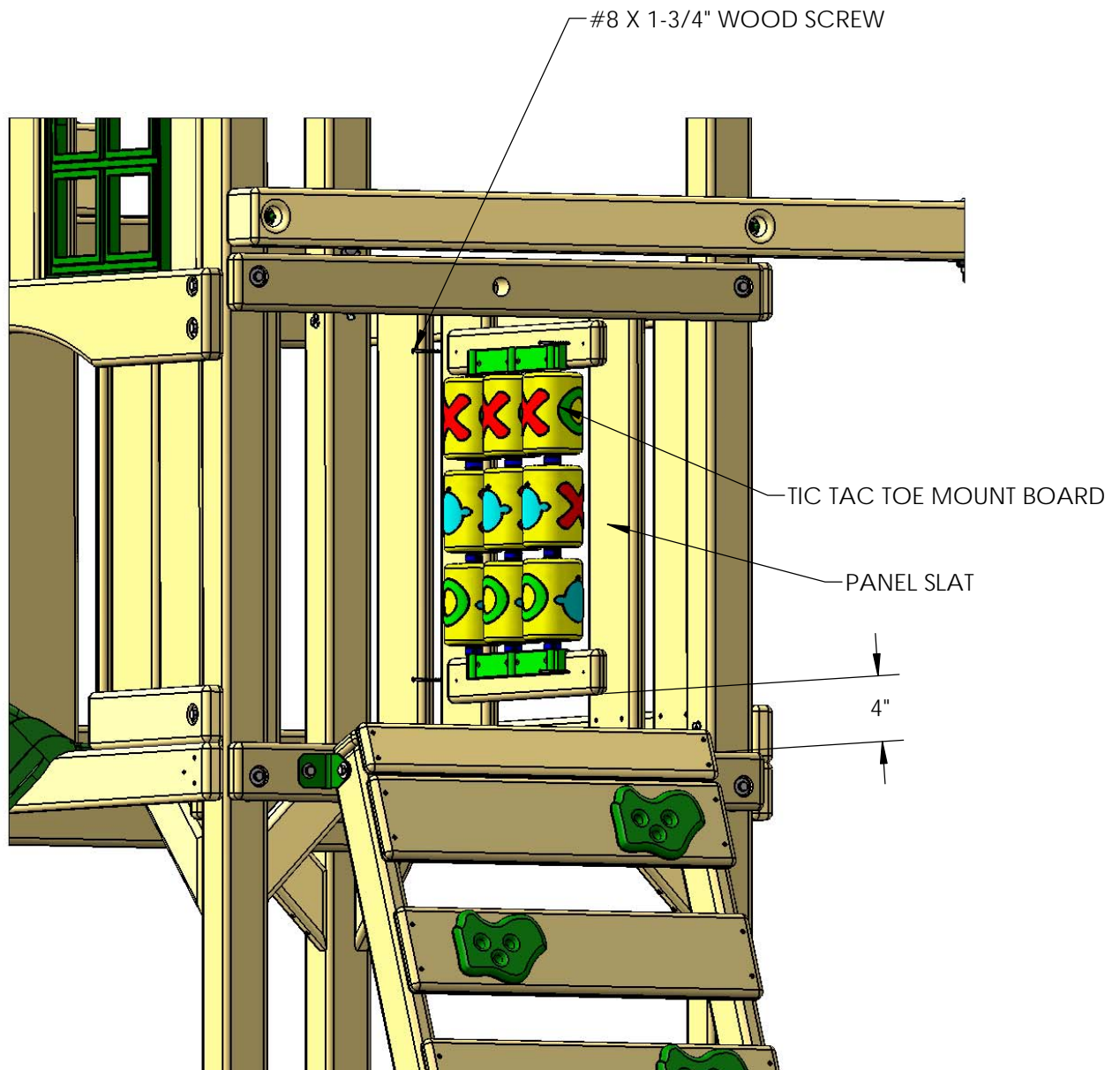

STEP 41: STEERING WHEEL

- 1: PLACE THE STEERING WHEEL INSERT INSIDE THE STEERING WHEEL. DRILL AN 11/64" HOLE 2" DEEP INTO THE END OF THE SWING BEAM.
- 2: USE THE HARDWARE INCLUDED WITH THE STEERING WHEEL TO MOUNT THE STEERING WHEEL TO THE END OF THE SWING BEAM. DO NOT OVER-TIGHTEN THE LAG SCREW INTO THE STEERING WHEEL, OR IT WILL NOT TURN.
- 3: PLACE THE STEERING WHEEL CAP OVER THE CENTER OF THE STEERING WHEEL. AND SNAP IT INTO THE STEERING WHEEL INSERT.

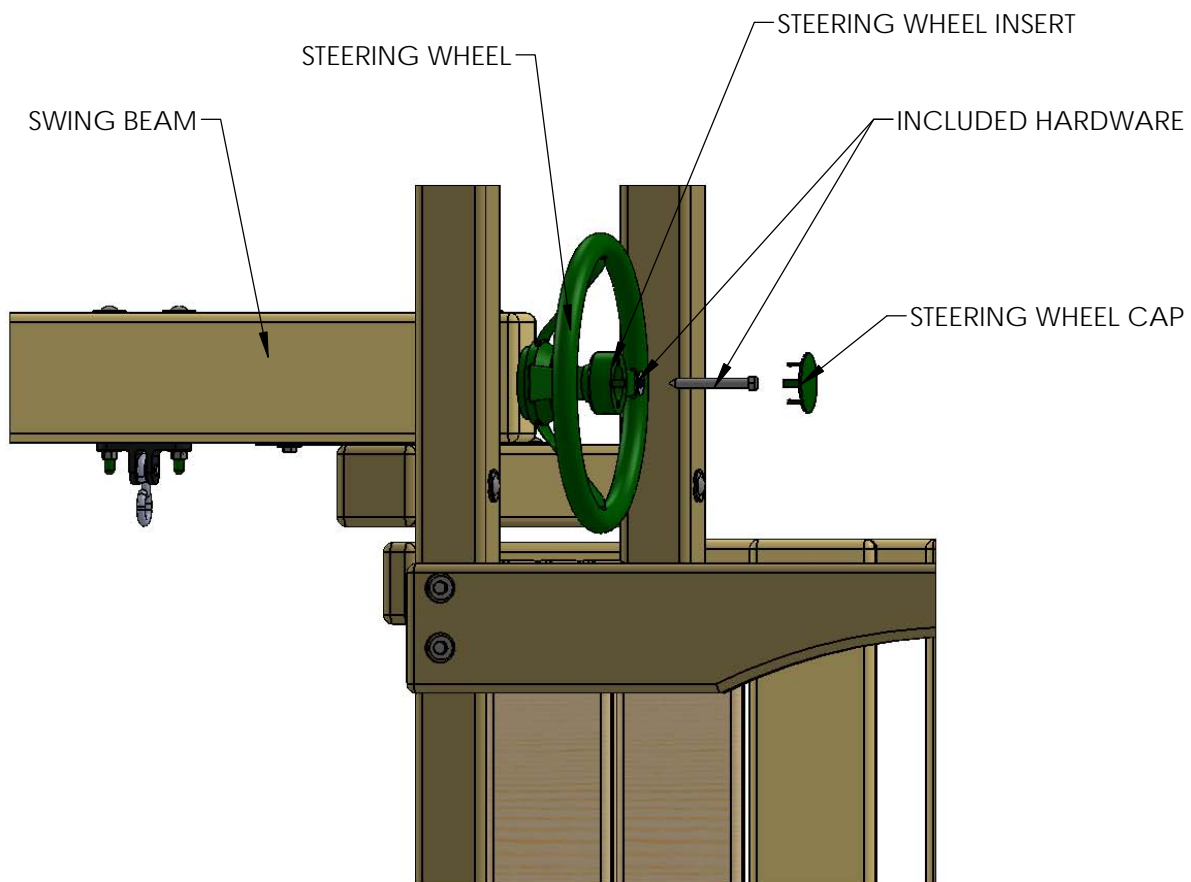

STEP 42: FLAG KITS

1: INSTALL THE FLAG KITS ON THE CORNER POSTS AT THE FRONT OF THE FORT. ATTACH THE FLAG KITS WITH THE HARDWARE PROVIDED.

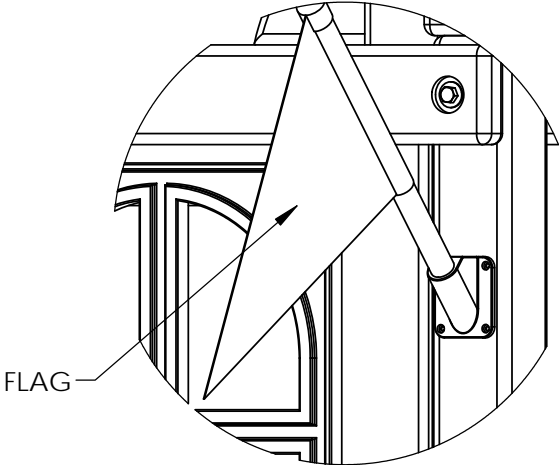

DETAIL A
SCALE 2 : 13

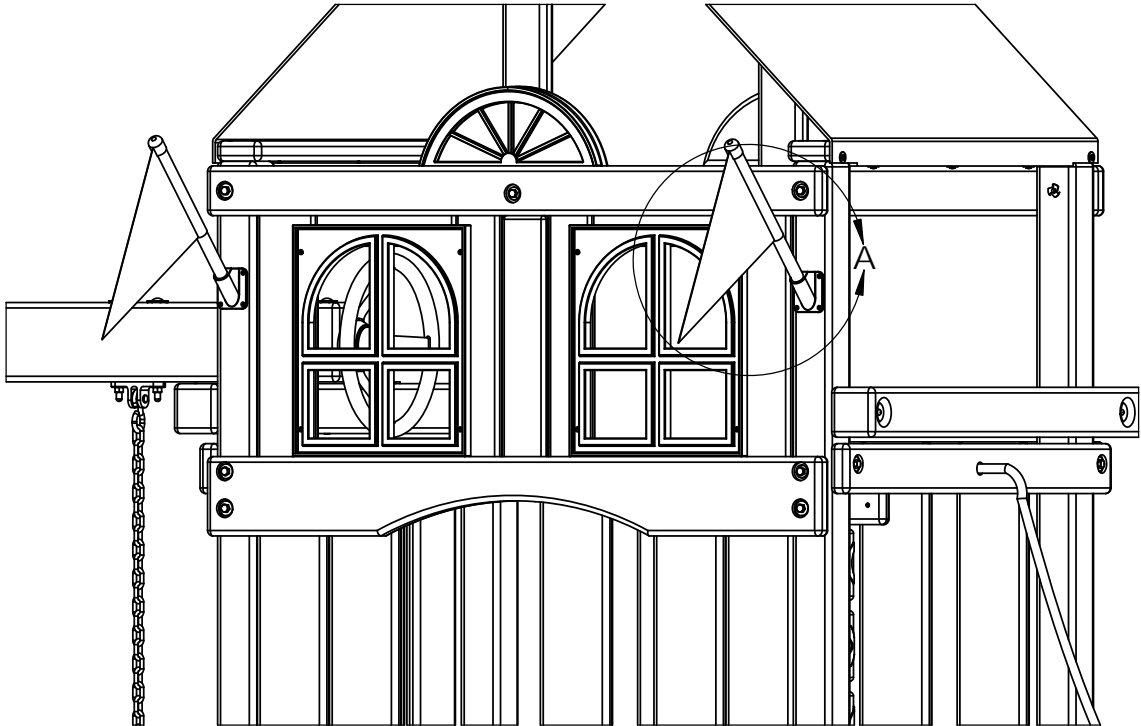

STEP 43: NAME PLATE

1: ATTACH THE NAME PLATE TO THE MIDDLE OF THE SWING BEAM WITH TWO 1-1/4" WOOD SCREWS.

ATTACH NAME PLATE HERE WITH TWO 1-1/4" WOOD SCREWS.

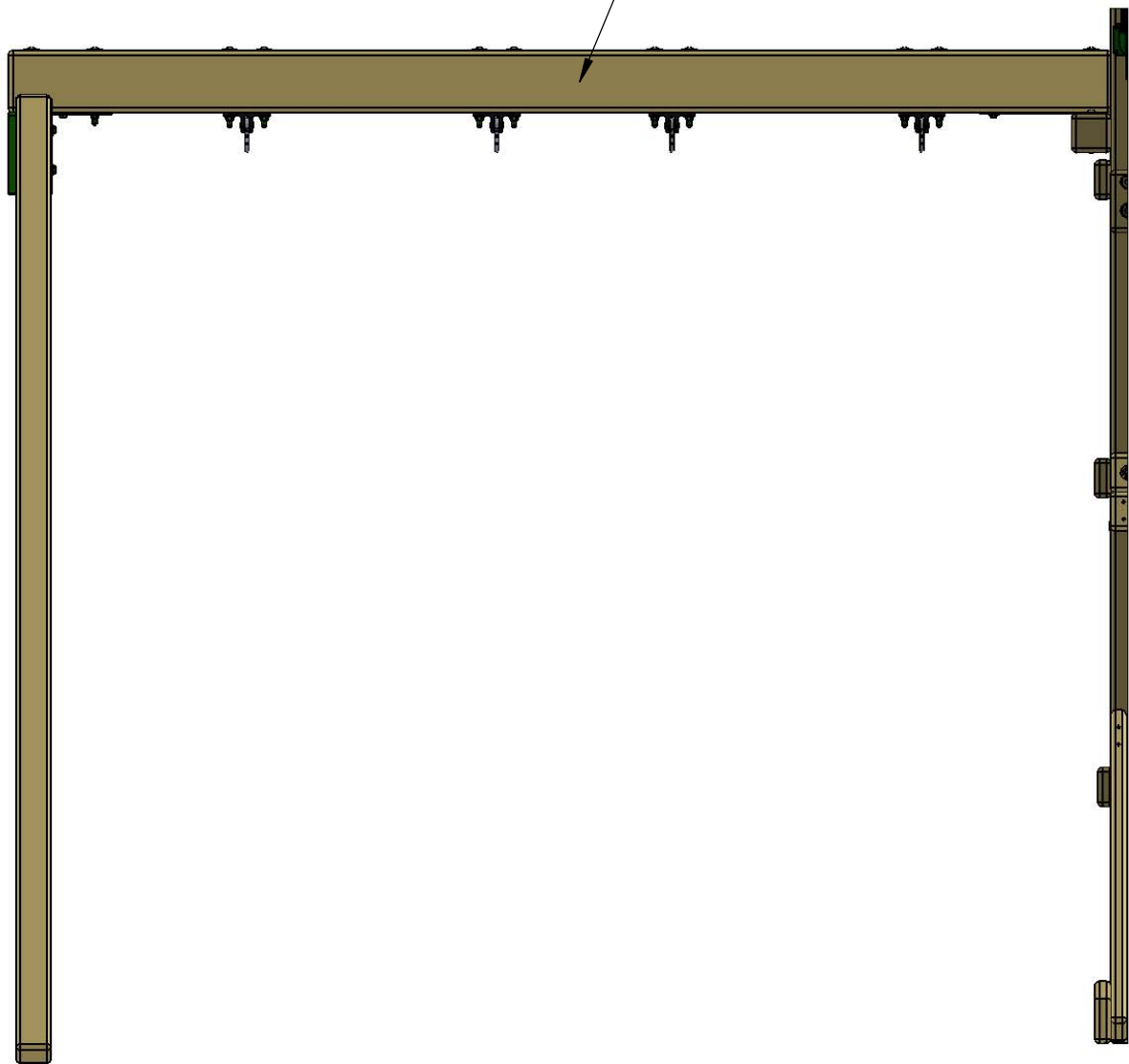

STEP 44: HANGING SWINGS

1: LOCATE TWO SWING BELTS WITH CHAINS ATTACHED.

2: PLACE A CHAIN LINK ONTO EACH SWING HANGER HOOK. ADJUST EACH SWING UP OR DOWN BY PLACING THE CHAIN LINKS HIGHER ONTO THE SWING HANGER HOOK.

3: LOCATE ONE TRAPEZE BAR WITH CHAINS ATTACHED.

4: PLACE A CHAIN LINK ONTO EACH SWING HANGER HOOK. ADJUST THE TRAPEZE UP OR DOWN BY PLACING THE CHAIN LINKS HIGHER ONTO THE SWING HANGER HOOK.

EXCESS CHAIN MAY BE LOOPED AND HOOKED ONTO THE END OF THE SWING HANGER HOOK.

****WARNING: DO NOT HANG SWING BELTS FROM TRAPEZE ARM****

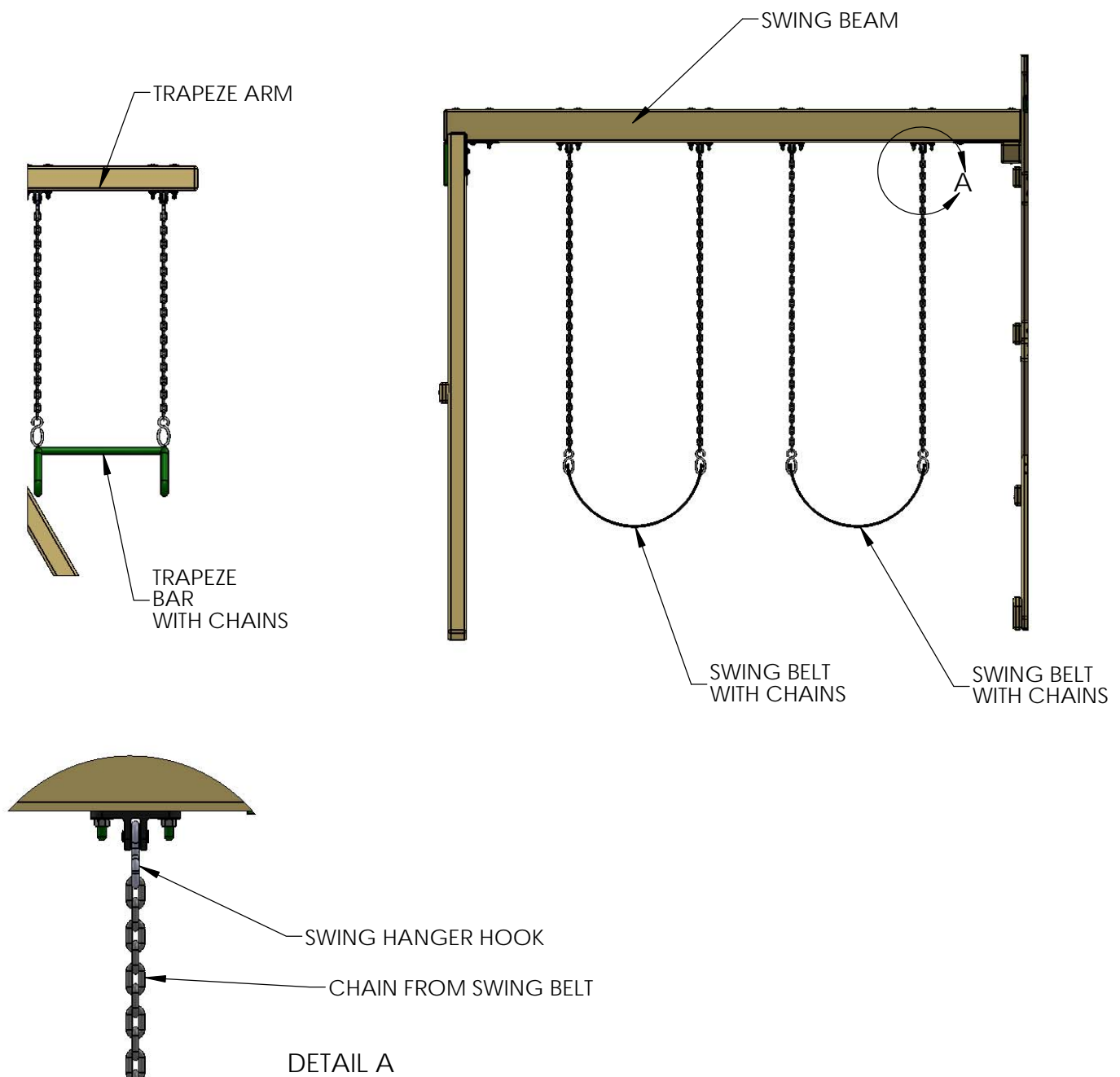

STEP 45: CHALKBOARD

1: ATTACH CHALKBOARD TO THE SLATS UNDER STEERING WHEEL WITH 3/4" PAN HEAD SCREWS.

NOTE: CHALKBOARD COMES WITH A MAGNETIC CHALK HOLDER WHICH WILL STICK TO THE CHALKBOARD.

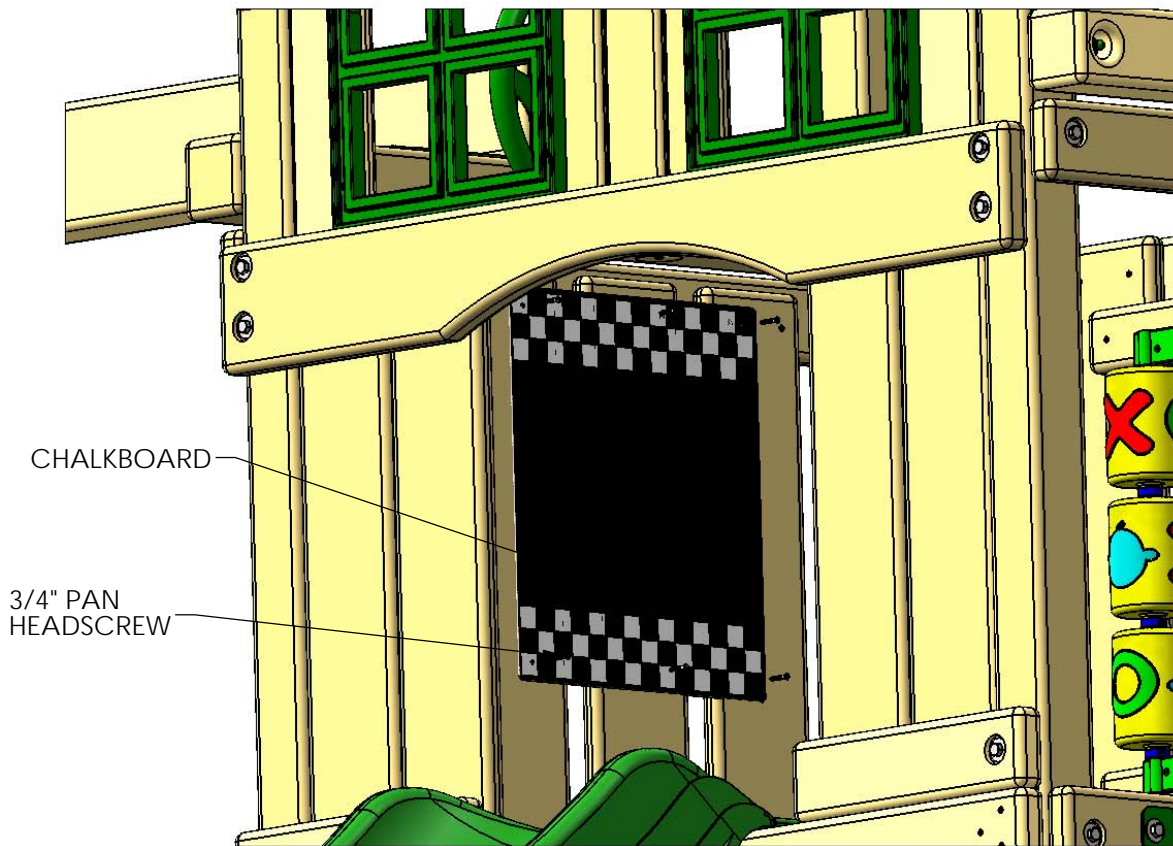

STEP 46: LOONEY PERISCOPE

THE PERISCOPE WILL BE MOUNTED ONTO THE REAR PANEL SLAT TO THE LEFT SIDE OF THE TIC TAC TOE.

- 1: FASTEN THE U-SHAPED BASE VERTICALLY ON THE REAR SLAT WITH 1-1/4" PHILIPS COUNTERSUNK HEAD SCREWS PROVIDED.
- 2: WHEN THE U-SHAPED BASE IS MOUNTED VERTICALLY AS SHOWN BELOW THE CHILD MAY SIMULATE THE UP AND DOWN MOVEMENT OF A REAL PERISCOPE. THE U-SHAPED BASE MAY ALSO BE MOUNTED HORIZONTALLY IF MOUNTING VERTICALLY IS NOT POSSIBLE.
- 3: SLIP THE BALL OF THE PERISCOPE INTO THE CHANNEL OF THE BASE.

!WARNING! **DO NOT LOOK INTO SUN OR OTHER BRIGHT LIGHTS WITH PERISCOPE**

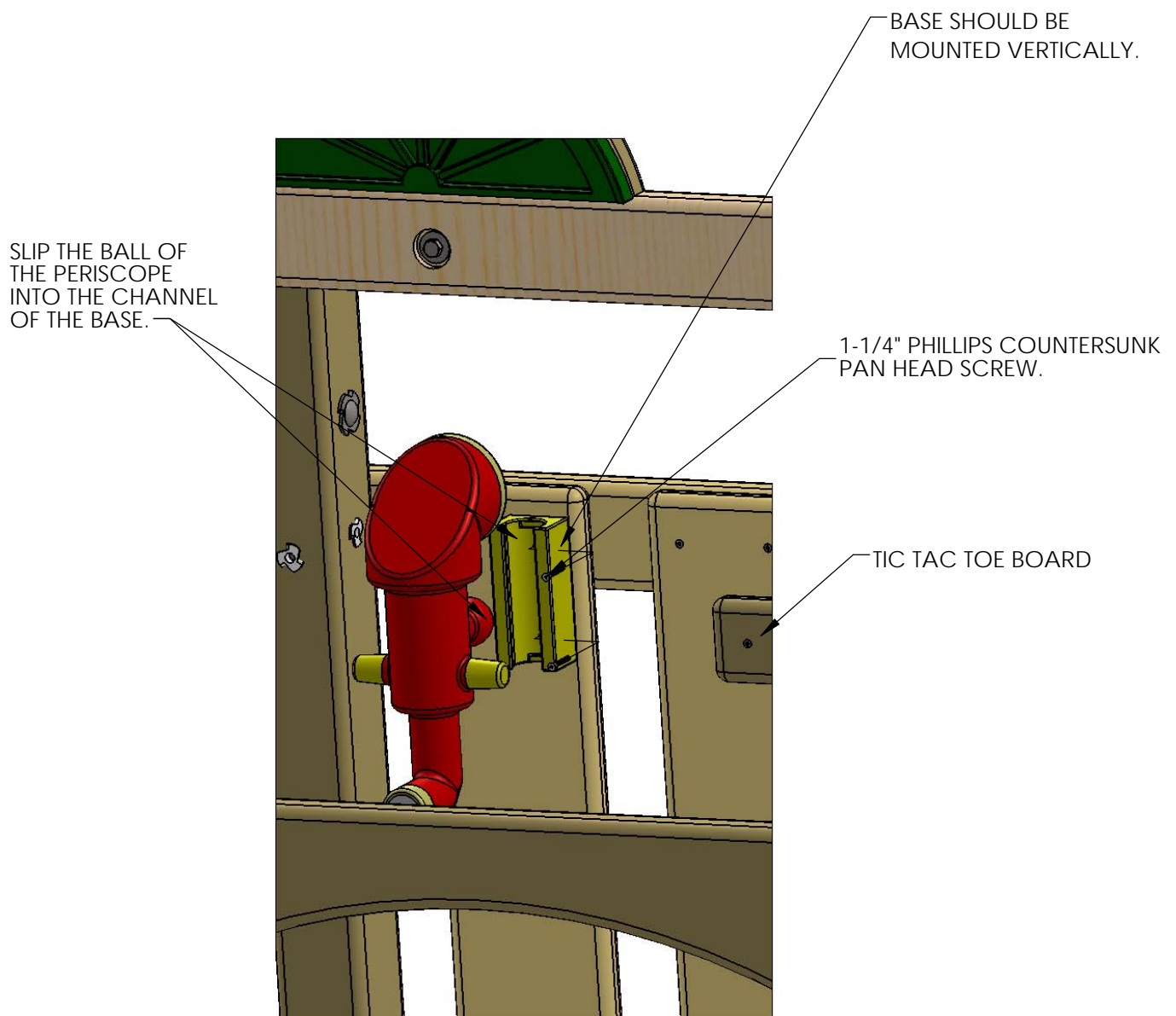

STEP 47: LOONEY TELESCOPE

1: FASTEN THE U-SHAPED BASE ON TOP OF THE TRAPEZE ARM WITH THE 1-1/4" PHILLIPS COUNTERSUNK HEAD SCREWS PROVIDED.

2: SLIDE THE BALL OF THE TELESCOPE INTO THE CHANNEL OF THE BASE.

!WARNING!DO NOT LOOK INTO SUN OR OTHER BRIGHT LIGHTS WITH TELESCOPE****

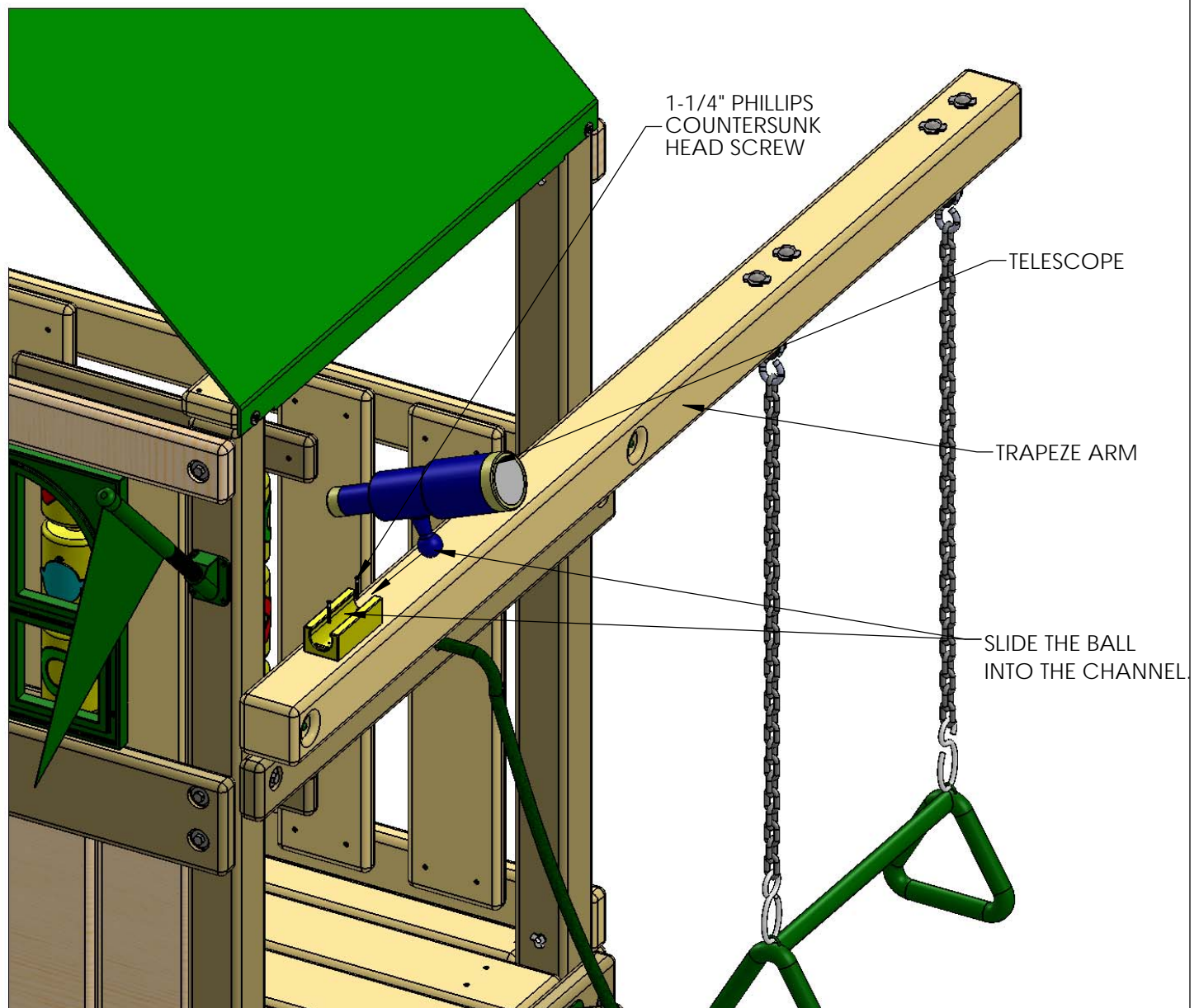

STEP 48: GROUND STAKES

1: PLACE THE GROUND STAKES ON THE OUTSIDE OF THE SWING LEGS AS SHOWN BELOW. HAMMER A GROUND STAKE INTO THE EARTH NEXT TO EACH SWING LEG AT AN ANGLE. DO NOT HOLD THE UPPER PORTION OF THE STAKE AFTER THE FIRST COUPLE OF HITS OR IT MAY VIBRATE HARSHLY AGAINST YOUR HAND. IF THE TOP PART OF THE STAKE TWISTS WHEN IT ENCOUNTERS A ROCK OR ROOT YOU MAY HAVE TO BEND THE TOP PORTION OF THE STAKE AGAINST THE SWING LEG. FINALLY INSTALL THE SCREW AND WASHER.

2: ATTACH EACH GROUND STAKE TO THE SWING LEG WITH A #14 X 2" PAN HEAD SCREW AND A 1/4" FENDER WASHER PROVIDED WITH THE GROUND STAKE.

3: HAMMER A GROUND STAKE ON THE INSIDE OF EACH CORNER POST. USE CAUTION WHEN HAMMERING SO THAT YOU DO NOT MAR THE WOOD. DO NOT HOLD THE UPPER PORTION OF THE STAKE AFTER THE FIRST COUPLE OF HITS OR IT MAY VIBRATE HARSHLY AGAINST YOUR HAND. LEAVE THE TOP PORTION OF THE GROUND STAKE ABOVE THE GROUND FAR ENOUGH SO THAT YOU CAN STILL GET THE SCREW INTO THE HOLE AT THE TOP OF THE STAKE.

4: ATTACH EACH GROUND STAKE TO THE CORNER POST WITH A #14 X 2" PAN HEAD SCREW AND A 1/4" FENDER WASHER PROVIDED WITH THE GROUND STAKE.

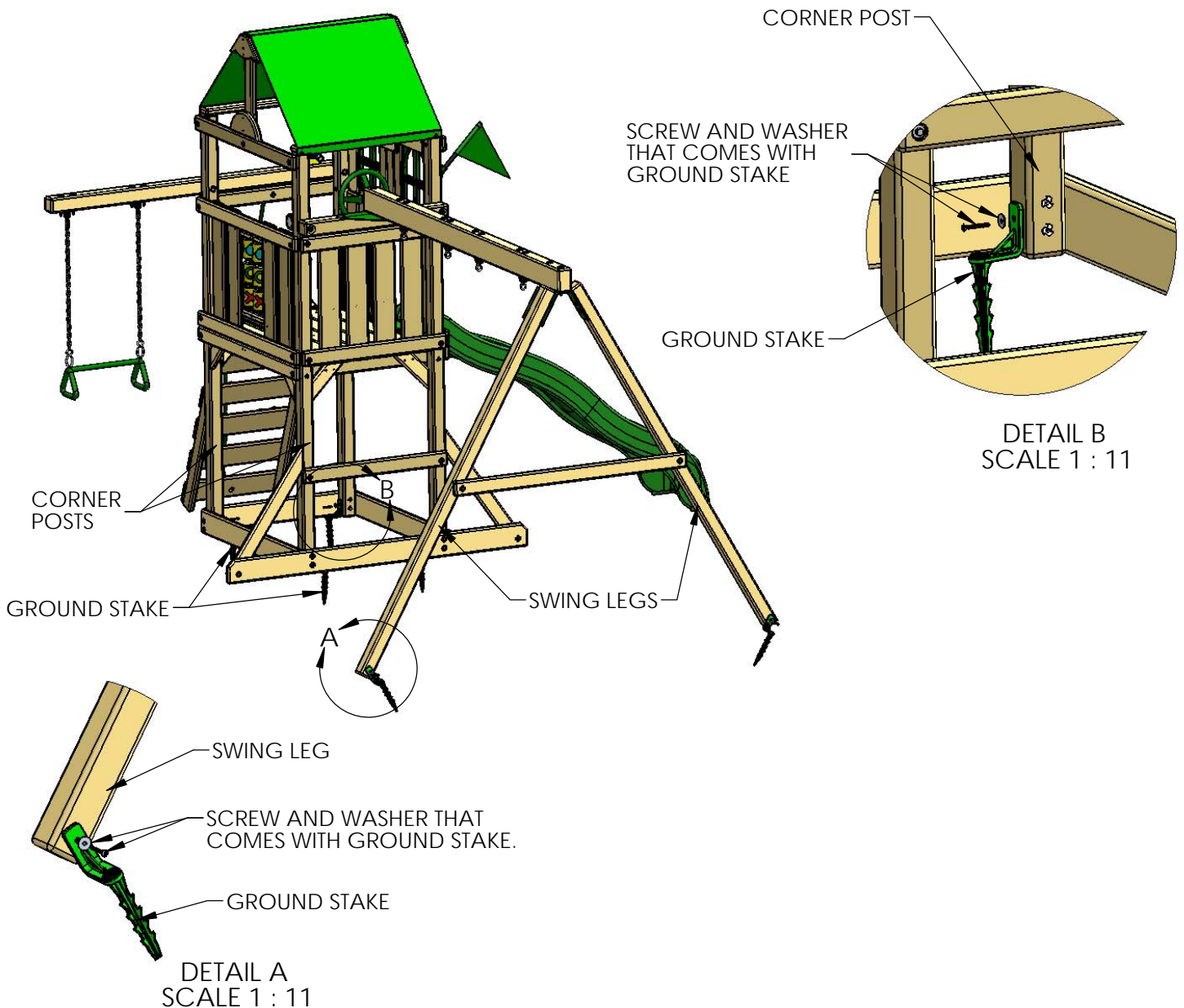

STEP 49: SANDBOX SEATS

1: PLACE THE 5/4 X 6 X 22" SANDBOX SEATS ONTO THE TOP OF THE SANDBOX BOARDS AS SHOWN BELOW.

2: ATTACH THE SANDBOX SEATS TO THE SANDBOX BOARDS WITH #8 X 2" WOOD SCREWS.

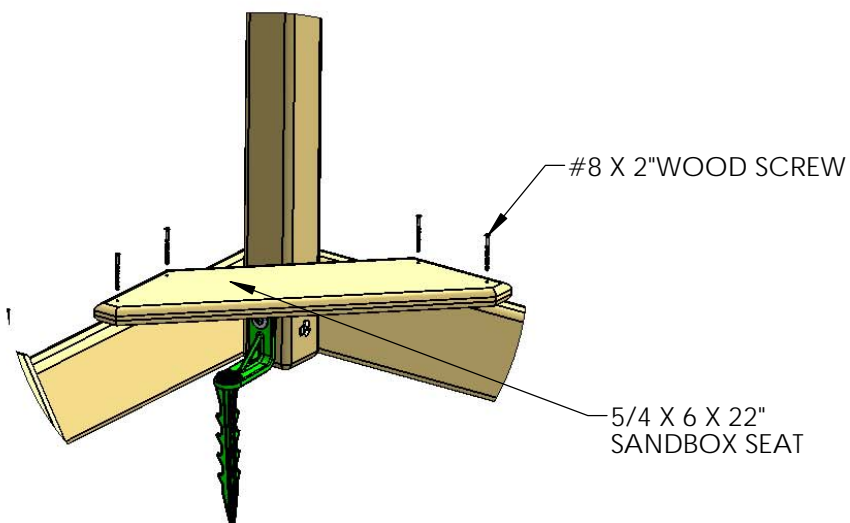

DETAIL A
SCALE 1 : 10

STEP 50: SAFETY HANDLES

- 1: LOCATE THE SAFETY HANDLE BAG.
- 2: ADJUST THE SAFETY HANDLES UP OR DOWN TO SUIT THE NEEDS OF YOUR CHILD.
- 3: ATTACH EACH SAFETY HANDLE TO THE CORNER POST WITH TWO PAN HEAD SCREWS AND TWO WASHERS PROVIDED WITH THE SAFETY HANDLES.

