

# gorilla

playsets



## Congo Swing Station ASSEMBLY MANUAL

Copyright © 2011 Gorilla Playsets  
All Rights Reserved

Gorilla Playsets • 190 Etowah Industrial Court • Canton, GA 30114 • (800) 882-0272

Latest Revision: April 4, 2011

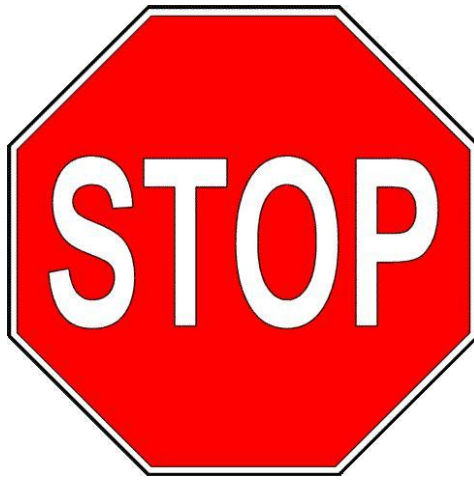

## **STOP...PLEASE READ!!**

**IF YOU HAVE MISSING OR DAMAGED PARTS OR NEED ASSISTANCE ASSEMBLING, PLEASE CALL **gorilla playsets™** MANUFACTURING DIRECT.**

**(800) 882-0272**

**FACTORY HOURS – MON.–FRI., 8AM-5PM EST**

DO NOT RETURN THIS PRODUCT TO THE RETAILER OR CONTACT THE RETAILER DIRECT. THE RETAILER DOES NOT STOCK COMPONENTS.

PLEASE RETAIN THESE INSTRUCTIONS FOR FUTURE REFERENCE. KEEP THEM IN A SAFE PLACE WHERE YOU CAN REFER TO THEM AS NEEDED.

### **CONTACT INFO:**

**Gorilla Playsets**  
190 Etowah Industrial Court  
**Canton, GA 30114**  
Tel. (678) 880-3328  
Fax. (678) 880-3329  
[custsrv@gorillaplaysets.com](mailto:custsrv@gorillaplaysets.com)

Check for revised instructions at [www.gorillaplaysets.com/support](http://www.gorillaplaysets.com/support)



# **Congo Swing Station**

---

## TABLE OF CONTENTS

Warranty and Safety Guidelines.....	4-9
Kit Contents and Tool List.....	10-13
Hardware and Lumber Checklist.....	14-16
Attaching Iron Ductiles to Swing Beam.....	Step 1
Attaching Swing Leg Bracket to Swing Beam.....	Step 2
Attaching Legs to Swing Leg Bracket.....	Step 3
Mounting the Swing Leg Cross Member.....	Step 4
Hanging Swings.....	Step 5
Customer Registration Card.....	22

**PLEASE READ OWNER’S MANUAL CAREFULLY BEFORE  
STARTING ASSEMBLY!**

## Thank you for choosing **gorilla playsets®** for your new backyard playground!

We've included everything you need, except tools, to build your very own professional looking playset. When complete, your new playset should far exceed the quality of playset kits from other build-your-own companies. Our engineers and design team have over 30 years of playground experience. What we've developed is a playset that doesn't compromise quality for simplicity. Yet you'll appreciate how quick and easy construction really is! Our playset kits are designed for children ages 3 to 11. **gorilla playsets®** believes every child should have a playset and with our kits they can! You can rest assured your new playset is safe, durable and designed to hold up to the elements. As parents ourselves, we know how important the security and well-being of our children is, and this shows in all of our products.

Each playset features our step-by-step 3D illustrated manual, patented powder coated swing beam bracket, heavy-duty swing belts with chains, slide(s), accessories, plus all the required hardware and pre-milled lumber.

### Quality Lumber

At Gorilla Playsets, we use only the finest, hand selected lumber available. Whether you choose a playset made from our Premium Preserved Pine, Beautiful California Redwood, Western Red Cedar, or Asian Cedar you can be assured that our lumber is strong, durable, and conforms to the national standards for use in children's play equipment. It's this quality that allows us to offer a 10 year warranty on the lumber used in our play sets.

### Premium Preserved Pine

Our Premium Preserved Pine is double kiln dried. We utilize this process to minimize shrinkage, warping, and cupping. Because our pine has been "pre-shrunk", the hardware used to assemble your playset will hold tight. Our preserved pine is clean, odorless, non-staining, and non-irritating to humans, animals, or plants. Gorilla's Preserved Pine uses one of the only exterior wood preservation systems that is EPA approved. Our pine lumber is preserved with a preservative system containing copper and azole compounds to protect against termite attack and fungal decay. Our Premium Preserved Pine can withstand harsh weather conditions and is effective for decades; making Gorilla Playsets the best choice in pine lumber built swing sets.

### California Redwood and Western Red Cedar\*

Our Beautiful California Redwood and Western Red Cedar play sets are a natural alternative to preserved lumber. California Redwood naturally resists decay caused by the environment or by insect infestation while Western Red Cedar is a preferred wood for purposes where an attractive appearance and resistance to weather is important. All California Redwood and Western Red Cedar Gorilla Playsets receive a factory stain and sealant process. To maintain this aesthetic appeal, it is recommended that you seal your redwood and cedar play set once per year.

### Asian Cedar (*Cunninghamia Lanceolata*)

Our durable Asian Cedar play sets are low-maintenance, and maintain their beauty for many years. Asian Cedar has been harvested in Southeast Asia for more than 800 years, and is prized because it naturally repels pests, fungus, and rot. Asian Cedar is used indoors and out where durability is critical. Asian Cedar can be found throughout the U.S. in outdoor lawn furniture, and on children's play structures.

\*Gorilla Playsets reserves the right to substitute Western Red Cedar with other species of similar characteristics due to market availability.

## Limited Manufacturers Warranty

**gorilla playsets®** warrants this product to be free from defects in workmanship and materials, under normal use and conditions, for a period of 10 years for structural wood components and one year for all other components (i.e., hardware, plastics, tarps, rope ladder, etc.). Cosmetic defects that do not affect the structural integrity of the product, or natural defects of wood such as warping, checking or any other physical properties of wood that do not present a safety hazard, are not covered by this warranty.

**gorilla playsets®** will repair, or, at its discretion, replace any part within the stated warranty period that is defective in workmanship or materials. This decision is subject to verification of the defect upon delivery of the defective part to **gorilla playsets®** at 190 Etowah Industrial Court, Canton, Georgia 30114. Any part(s) returned to **gorilla playsets®** must include proof and date of purchase.

This warranty is valid only if the product is used for the purpose for which it was designed and installed at a residential, single-family dwelling. This warranty is void if the product is put to commercial or institutional use. This warranty does not cover (a) products which have been damaged by negligence, natural disasters, or accident by improper use, or which have been modified or repaired by unauthorized persons, (b) the cost of labor, or (c) the cost of shipping the product, any part, or any replacement product or part.

This warranty is valid only in the United States of America, is non-transferable and does not extend to the owners of the product subsequent to the original purchaser. **gorilla playsets®** disclaims all other representations and warranties of any kind, express, implied, statutory or otherwise, including the implied warranties of merchantability and fitness for a particular purpose. **gorilla playsets®** will not be liable for any incidental or consequential damages. Some states do not allow limitations on implied warranties or exclusion of incidental or consequential damages, so these restrictions may not be applicable to you. This warranty gives you specific legal rights. You may also have other rights that vary from state to state.

### IMPORTANT SAFETY GUIDELINES

This product is intended for residential use only and not intended for use in any public setting. A safety surface such as mulch or recycled tire should be used under the play set to prevent injury from falls. Also a 6 foot safety zone should be used around the entire playset.

As with any home project, good judgment and respect for power tools will greatly reduce the risk of injury. **gorilla playsets®** recommends you follow all tool manufacturers' safety guidelines. Always wear eye protection and safety gloves to prevent injury. In several phases of construction two people may be required for lifting and securing of lumber. While playset is being constructed, please keep children off the equipment until the project is complete. Bolts and screw heads should be checked regularly for tightness. The ground ladder, rope ladder, slide, swings and other areas where children spend a majority of their playtime should be checked more frequently.

**gorilla playsets®** shall not be liable for incidental, indirect or consequential damages or injuries that result from the building and/or playing on our playsets. Adult supervision is recommended anytime a playset is being used.

## **WEIGHT LIMITS FOR GORILLA PLAYSETS**

- FORT PLATFORMS: 800 LBS. TOTAL WEIGHT
- SWING BELTS: 175 LBS.
- GLIDER SWINGS: 70 LBS. PER CHILD
- TRAPEZE: 125 LBS.
- FULL BUCKET SWING: 50 LBS.
- TODDLER BUCKET SWING: 50 LBS.
- INFANT SWING: 35 LBS.
- TIRE SWING: 125 LBS. TOTAL WEIGHT
- ROPE LADDER: 75 LBS.
- ROCK WALL: 150 LBS.
- ALL SLIDES: 125 LBS.

**Gorilla Playsets recommends that the weight limits for all components must not be exceeded. Failure to adhere to these and other safety guidelines could result in damage to the playset and injury to the users.**

## Safety and Maintenance Tips for Your New Play Set:

**NOTE:** Your children's safety is our #1 concern. Observing the following statements and warnings reduces the likelihood of serious or fatal injury. Please review these safety rules regularly with your children.

- This playset is designed for the use of 3 occupants who have a combined weight **not exceeding** 525 pounds on the swing area.
- On-site adult supervision is **required**.
- Teach children **not** to walk close to, in front of, behind, or between moving swings or other moving playground equipment.
- Teach children to sit in and **never** stand on swings
- Teach children **not** to twist the chains and ropes and not to loop them over the swing beam, since this may reduce the strength of the chain or rope.
- Teach children **not** to jump from swings or other playground equipment in motion.
- Teach children to **not push** empty seats. The seat may hit them and cause serious injury.
- Teach children to sit in the center of the swings with their full weight on the seats.
- Teach children **not** to use the equipment in a manner other than intended.
- Parents should have children **dress appropriately** with well-fitting shoes. Loose clothing such as scarves and ponchos should not be worn. Always take off, tie up or tuck in cords and drawstrings on children's clothing. These things can get caught on playground equipment and strangle a child.
- Teach children **not** to climb when the equipment is wet.
- Verify that any suspended climbing ropes, chains, or cables are secured at both ends and that they cannot be looped around an adult hand.
- Teach children **not** to attach items to the playground equipment that are not specifically designed for use with the equipment, such as, but not limited to, jump ropes, clothesline, pet leashes, cables and chain as they may cause a strangulation hazard.
- Teach children to **never** wrap their legs around swing chain.
- Teach children to **never** slide down the swing chain.

**WARNING: Children must NOT use this playset until unit has been completely assembled and inspected by an adult to insure set has been properly installed and anchored.**

## **Safety and Maintenance Tips for Your New Play Set: (continued)**

Playgrounds should be inspected on a regular basis. If any of the following conditions are noted, they should be removed, corrected, or repaired immediately to prevent injuries.

- Hardware that is loose, worn or that has protrusions or projections
- Exposed equipment footings
- Scattered debris, litter, rocks, or tree roots
- Splinters, large cracks, and decayed wood components.
- Deterioration and corrosion on structural components, which connect to the ground
- Missing or damaged equipment components, such as handholds, guardrails, swing seats.
- Check all nuts and bolts frequently during the usage season and tighten as required. (But not so tight that you crack the wood) We recommend you check the swing beam and hardware often due to wood expansion and contraction. It is particularly important that this procedure be followed at the beginning of each season.
- Remove plastic swing seats and take indoors or do not use when the temperature drops below 32°F.
- Oil all metallic moving parts monthly during the usage period.
- Check all coverings for bolts and sharp edges twice monthly during usage season to be certain they are in place. Replace when necessary. It is especially important to do this at the beginning of each new season.
- Check swing seats, ropes, cables and chains monthly during usage season for evidence of deterioration. Replacement should be made of any swing seat that has developed cracks in the plastic seats or has exposed metal in the edges of the swing seat. If there are already exposed metal inserts on the edge of the seat, immediately remove the seats and chains to prevent serious injury. Ropes, cables and chains should be removed and replaced if excessive wear is found. Contact Gorilla Playsets for warranted replacement parts.
- For rusted areas on metallic members such as monkey bars, hand supports brackets, etc.; sand and repaint, using a non lead-based paint meeting the requirements of Title 16 CRF Part 1303.
- Inspect wood parts monthly. The grain of the wood sometimes will lift in the dry season causing splinters to appear. Light sanding may be necessary to maintain a safe playing environment. If you are treating your playset with stain regularly, it will help prevent severe checking/splitting and other weather damage.
- Once or twice a year, depending on your climate conditions, you must apply some type of protection (sealant) to the wood of your unit. Prior to the application of sealant, lightly sand any "rough" spots on your set. Please note this is a requirement of your warranty.
- Creating and maintaining the playset on a level location is very important. As your children play, your playset will slowly dig its way into the soil, and it is very important that it settles evenly. Make sure the play set is level and true once each year or at the beginning of each play season.
- Rake the surface periodically to prevent compaction and maintain appropriate depths.

***Disposal Instructions:*** When the playset use is no longer desired, it should be disassembled and disposed of in such way that no unreasonable hazards will exist at the time the unit is discarded.



## Play Set Surfacing Recommendations:

Below are some of the recommendations that the U.S. Consumer Product Safety Commission (CPSC) offers from its *Handbook for Public Playground Safety*. The guide can be downloaded in full at [www.cpsc.gov/cpscpub/pubs/325.pdf](http://www.cpsc.gov/cpscpub/pubs/325.pdf)

**1. Protective Surfacing** - Since almost 60% of all injuries are caused by falls to the ground, protective surfacing under and around all playground equipment is the most critical safety factor on playgrounds.

Certain manufactured synthetic surfaces also are acceptable; however, test data on shock absorbing performance should be requested from the manufacturer.

Asphalt and concrete are unacceptable. They do not have any shock absorbing properties. Similarly, grass and turf should not be used. Their ability to absorb shock during a fall can be reduced considerably through wear and environmental conditions.

Certain loose-fill surfacing materials are acceptable. Surfacing materials are acceptable, such as the types and depths shown in the table.

## Fall Heights and Materials

Material	Uncompressed Depth			Compressed Depth to 9" (228mm)
	6" (152mm)	9" (228mm)	12" (304mm)	
Wood Chips	7' (2.13m)	10' (3.05m)	11' (3.35m)	10' (3.05m)
Double-Shredded bark mulch	6' (1.83m)	10' (3.05m)	11' (3.35m)	7' (2.13m)
Engineered Wood Fibers	6' (1.83m)	7' (2.13m)	>12' (3.66m)	6' (1.83m)
Fine Sand	5' (1.52m)	5' (1.52m)	9' (2.74m)	5' (1.52m)
Coarse Sand	5' (1.52m)	5' (1.52m)	6' (1.83m)	4' (1.22m)
Fine Gravel	5' (1.52m)	7' (2.13m)	10' (3.05m)	6' (1.83m)
Medium Gravel	5' (1.52m)	5' (1.52m)	6' (1.83m)	5' (1.52m)
Shredded Tires*	10-12' (3.0-3.6m)	N/A	N/A	N/A

\*This data is from tests conducted by independent testing laboratories on a 6-inch depth of uncompressed shredded tire samples produced by four manufacturers. The tests reported critical heights, which varied from 10 feet to greater than 12 feet. It is recommended that persons seeking to install shredded tires as a protective surface request test data from the supplier showing the critical height of the material when it was tested in accordance with ASTM F1292.

It should be recognized that all injuries due to falls cannot be prevented no matter what surfacing material is used.

**2. Fall Zones** - A fall zone, covered with a protective surfacing material, is essential under and around equipment where a child might fall. This area should be free of other equipment and obstacles onto which a child might fall. Stationary climbing equipment and slides should have a fall zone extending a Minimum of 6' in all directions from the perimeter of the equipment.

Swings should have a fall zone extending a minimum of 6' from the outer edge of the support structure on each side. The fall zone in front and back of the swing should extend out a minimum distance of twice the height of the swing as measured from the ground to the top of the swing support structure.

# Congo Swing Station

## KIT CONTENTS

### COMPONENTS

Description	Qty	Check List
<b><i>(Swings, Slides, Accessories)</i></b>		
Trapeze Swing w/Chains	1	_____
Swing Belt w/ Chains	2	_____
The Swing Station Assembly Manual	1	_____

**Description**  
***(Fort Hardware)*** ***see following pages***

**Description**  
***(Swing Beam Hardware)*** ***see following pages***

**Description**  
***(Wood Components)*** ***see following pages***

### REQUIRED TOOL LIST

- Standard or Cordless Drill w/ Phillips Bit (#3 Philips bit provided)
- 9/16" Wrench, Socket, and Deep Well Socket
- Level
- Tape Measure
- Extension Cord (if using standard drill)
- Hammer
- Pencil
- Locking Pliers
- Shovel
- Rubber Mallet

Please familiarize yourself with the manual, parts/components and general construction process of your new playset before getting started.

**SITE PLAN:**

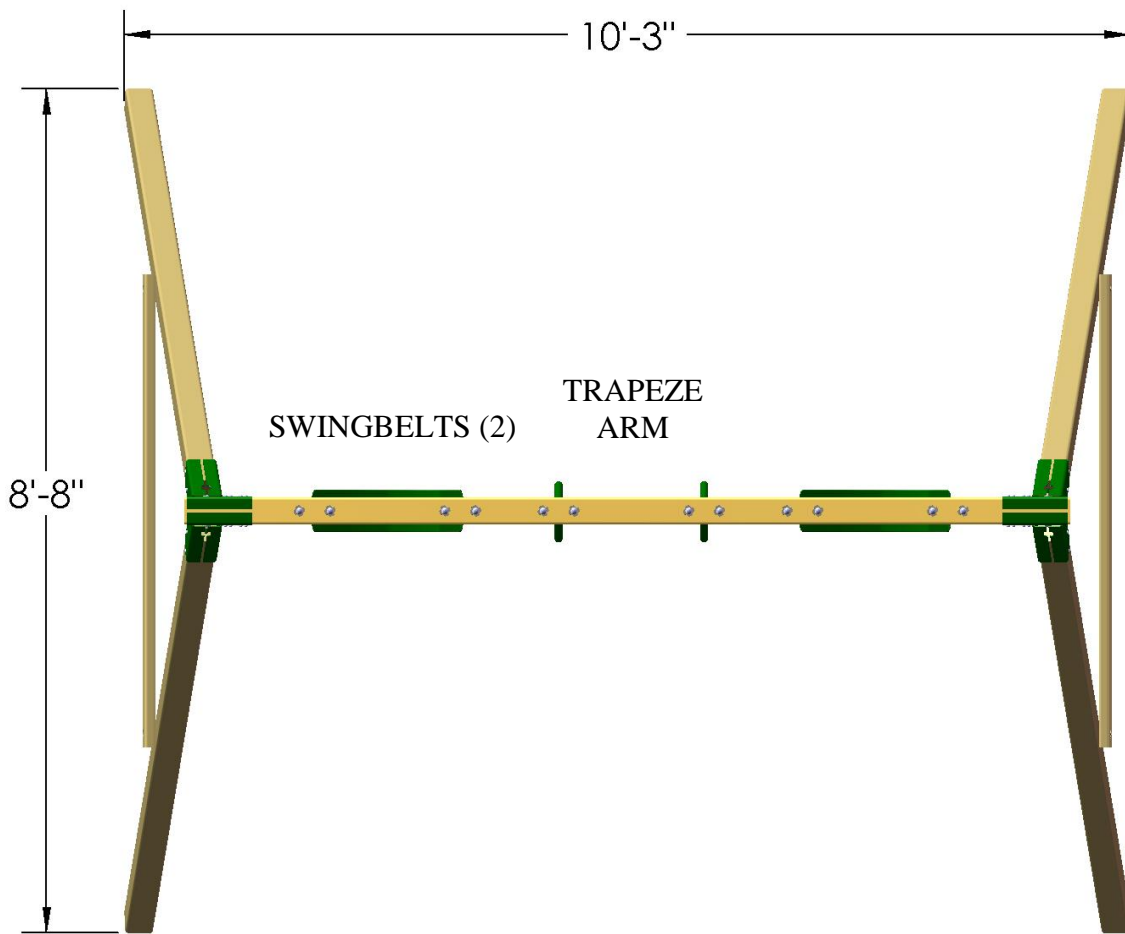

**Playset height: 7'-5"**

**Approximate assembly time:**

2-4 Hours

**{ 6 foot unobstructed safety perimeter around playset recommended }**

## *Helpful Installation Hints*

- Depending on your experience, assembly of Gorilla play sets can take as little as 6 hours up to 24 hours, depending on size, after inventory of parts; therefore, we recommend you set aside a full two days for assembly.
- Identify all of the parts for your playset. Empty each box and lay out boards so you can see each part. Your instruction book will have detailed drawings that will make it easy for you to recognize individual parts. Keep all hardware and metal parts separate from wooden pieces.
- After everything is laid out, check carefully to ensure all parts are present. Make sure there are no broken boards.
- Find an area to sort your hardware. It is best to open the hardware on a solid surface so that you do not lose any pieces in the grass. This will save time and familiarize you with all the different pieces in the hardware bag.
- Important note: Wood has some natural defects such as knots, surface cracks, etc. We reject parts that are structurally defective. We use a high quality lumber in our structures; however, during shipping, boards may rub together, causing rough spots. You should inspect each part for splinters or rough spots and sand them smooth to prevent injury.
- After familiarizing yourself with all of the components, read all instructions thoroughly. Reading instructions after you have studied the parts will help you understand more clearly the installation process, and help to eliminate unnecessary mistakes.
- Pay close attention to the diameter and length of each bolt and screw.
- Never tighten hardware completely at first. It helps to have some adjustment for bolt alignment while you are attaching parts together. After everything is square, tighten each joint.
- After you complete installation, make sure every bolt, screw, and nut is tight, and every board is secure. Wood will expand and contract with the seasons. Check all bolt connections and swing hangers seasonally.
- Place the set on level ground, not less than 6ft from any structure or obstruction such as a fence, garage, house, overhanging branches, laundry lines, or electrical wires.

### **READ! VERY IMPORTANT!**

If you are missing parts or have questions regarding the installation of our quality product PLEASE call us directly at the factory **(1-800-882-0272)**. Our trained staff will be happy to assist you.

#### **Customer service hours:**

**Monday thru Friday 8AM – 5PM EST**

**E-mail: [custsrv@gorillaplaysets.com](mailto:custsrv@gorillaplaysets.com)**

# General Info To Review Before Installation

This page is a list of definitions and explanations used throughout our instructions to aid you in the assembly of your playset.

**Counter-sunk holes-** Many of the parts that will be used have counter-sunk holes. A counter-sunk hole is one that surrounds one side of a thru hole, but does not extend through the wood it's self. When using a counter-sunk hole the bolt will be inserted through the thru hole and either the head of the bolt and washer or nut and washer will occupy the counter sunk hole.

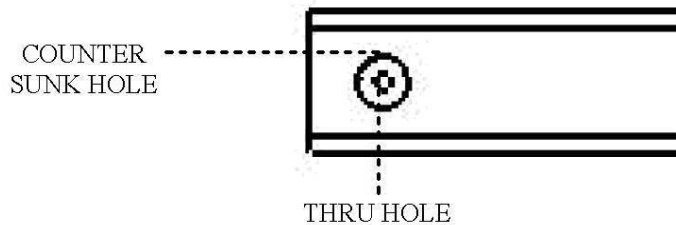

**Lag Screws-** Lag screws are used in the construction of our play sets to enhance the structural integrity of the unit. There will not be predrilled holes in the post for lag screw installation. Lag screws are self-tapping, though if you are using a manual socket wrench it may be necessary to tap the head of the lag screw with a hammer. You should also be sure to tighten the lags completely. Power tools such as an impact wrench or power drill should have enough torque to drive the lag screws without using a hammer, but make sure not to over tighten as this can cause the threads to "strip out" in the post.

3/8 X 3-1/2"  
HEX LAG SCREW  
QTY: 4



#14 X 2"  
PAN HEAD SCREW  
QTY:32



3/8" LOCK NUT  
QTY: 14



#3 PHILIPS BIT  
QTY: 1

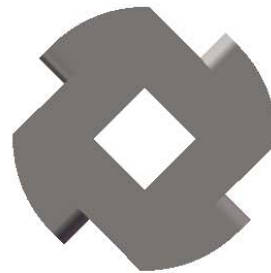

TORQUE WASHER  
QTY: 12



BOLT CAP  
QTY: 14



3/8" WASHER  
QTY: 18

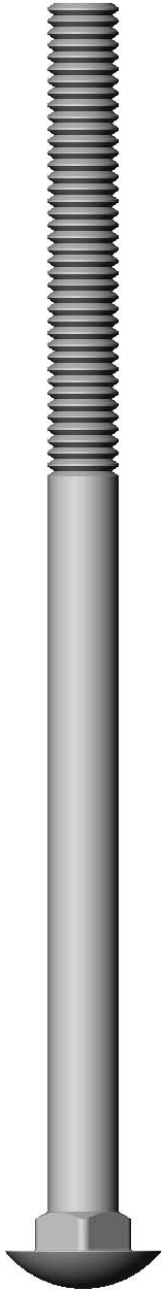

3/8 X 6-1/2"  
CARRIAGE BOLT  
QTY: 12

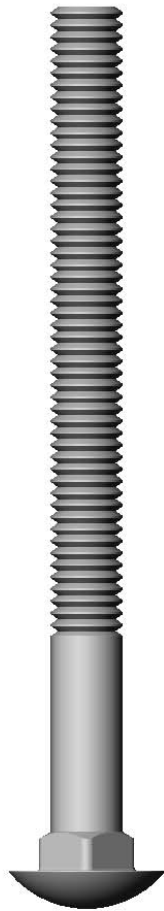

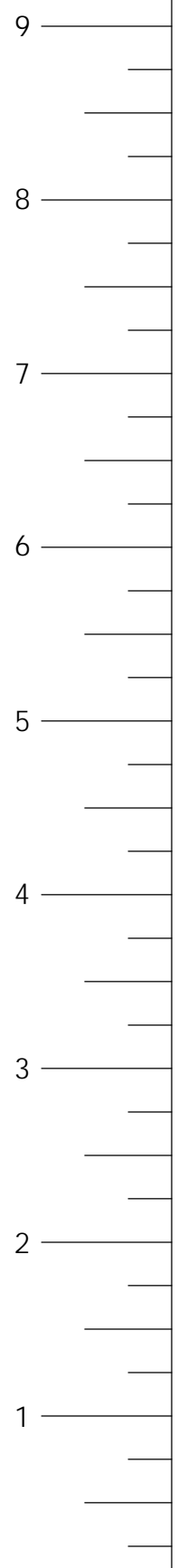

3/8 X 4-1/2"  
CARRIAGE BOLT  
QTY: 2

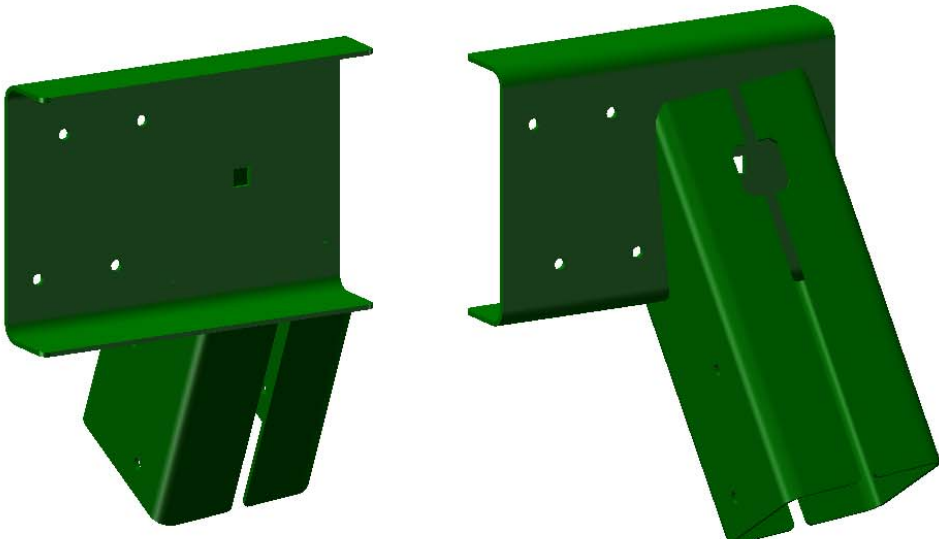
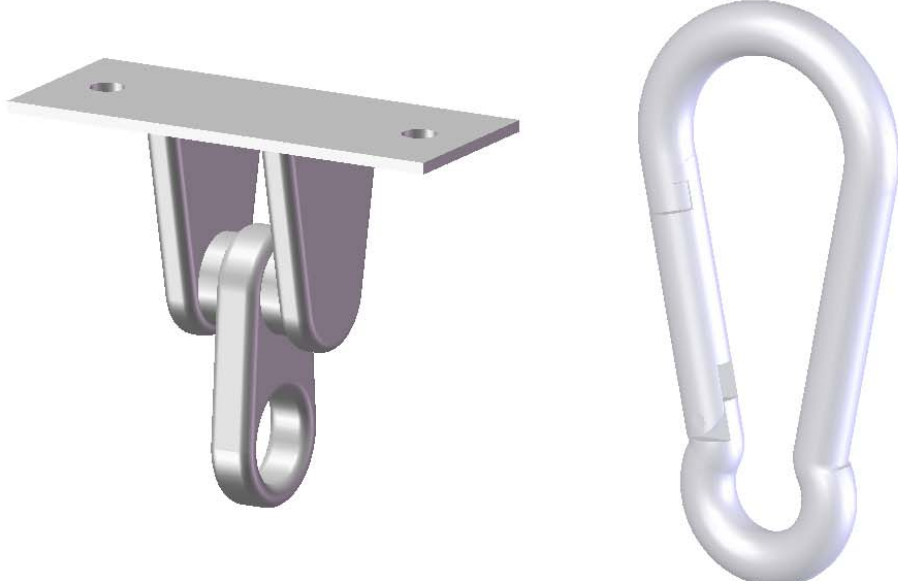

USE THE RULER TO THE RIGHT TO MEASURE YOUR BOLTS AND SCREWS. PICTURE VIEWS SHOWN ABOVE ARE 1:1 SCALE AND CAN BE USED TO MATCH BOLT AND SCREW SIZES.

PICTURE	DESCRIPTION	QTY.
	2 X 4 X 58" SWING LEG CROSS-MEMBER	2
	4 X 4 X 96" SWING LEG	4
	4 X 6 X 108" SWING BEAM	1
		15

PICTURE	DESCRIPTION	QTY.
	<p>2-PIECE SWING LEG BRACKET</p>	<p>2 LEFT 2 RIGHT</p>
	<p>IRON DUCTILE  SPRING CLIP</p>	<p>6</p>
	<p>SWINGS W/CHAINS  TRAPEZE BAR W/CHAINS</p>	<p>2  1</p>



# STEP 1: IRON DUCTILES

1: LINE UP THE HOLES OF THE IRON DUCTILES WITH THE HOLES IN THE SWING BEAM.

2: FASTEN THE IRON DUCTILES TO THE SWING BEAM USING 6-1/2" CARRIAGE BOLTS WITH TORQUE WASHERS ON TOP OF THE SWING BEAM, AND 3/8" LOCK NUTS AND WASHERS ON THE BOTTOM. PLACE GREEN BOLT CAPS OVER EXPOSED THREADS AFTER SECURING.

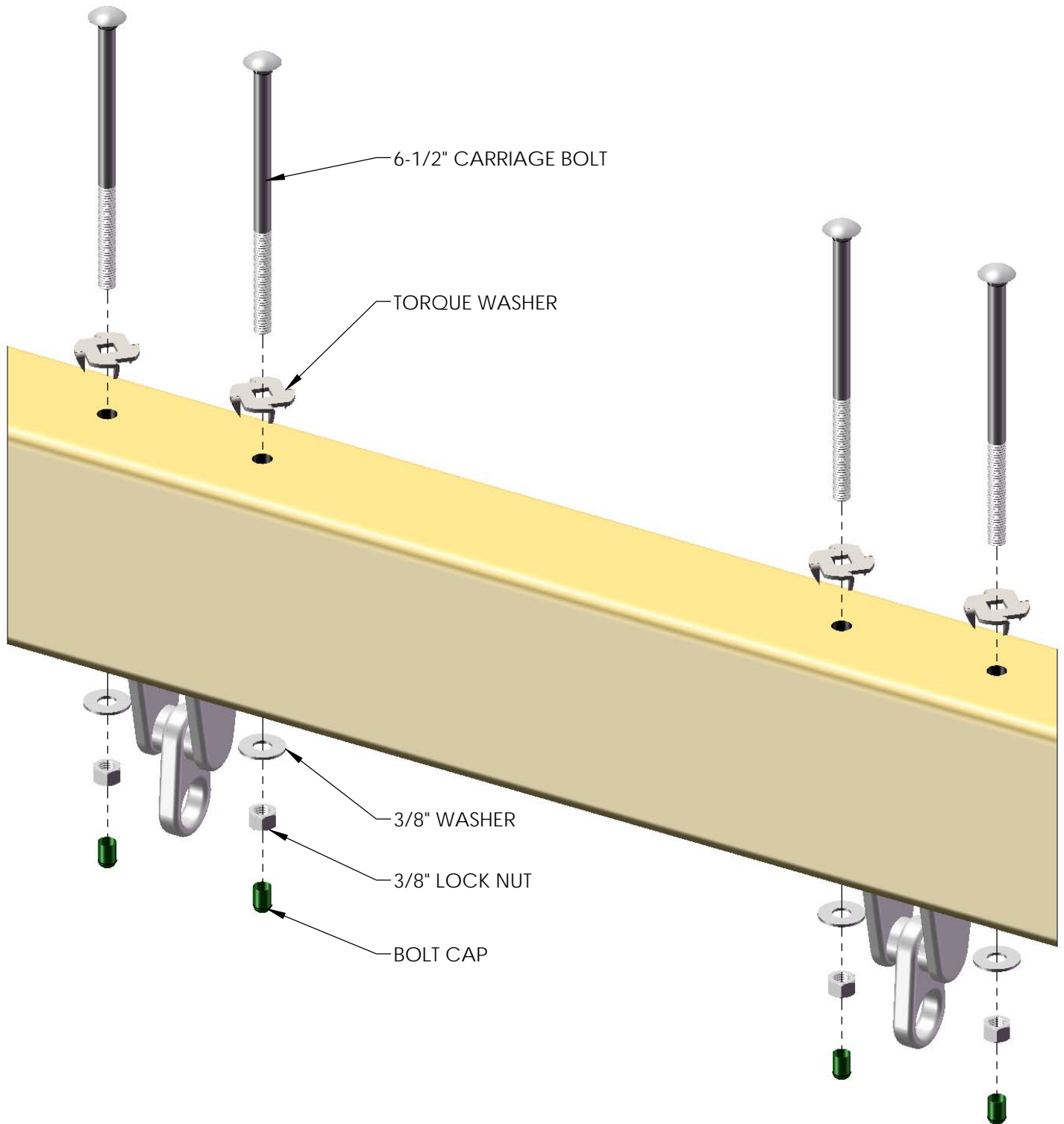

## STEP 2: SWING LEG BRACKETS

- 1: FIND THE FOUR HALVES OF THE SWING LEG BRACKETS.
- 2: MATCH UP THE BRACKETS SO THAT THE HOLES FOR THE LEGS WILL ANGLE AWAY FROM THE SWING AREA.
- 3: USE A 4-1/2" CARRIAGE BOLT IN THE SQUARE HOLE ON THE SIDE OF THE SWING LEG BRACKET. NOTE THE SQUARE PART OF THE NECK ON THE CARRIAGE BOLT. THIS WILL FIT INSIDE THE SQUARE HOLE ON THE SWING LEG BRACKET.
- 4: USE 3/8" WASHERS WITH LOCK NUTS ON THE OPPOSITE END OF THE SWING LEG BRACKET. YOU MAY NEED TO USE LOCKING PLIERS TO HOLD THE CARRIAGE BOLT IN PLACE WHEN TIGHTENING THE LOCK NUTS.
- 5: PLACE GREEN BOLT CAPS ON THE EXPOSED THREADS OF THE CARRIAGE BOLTS.
- 6: LOCATE THE FOUR HOLES ON THE SIDE OF THE SWING LEG BRACKET AND USE 2" PAN HEAD SCREWS IN EACH HOLE.

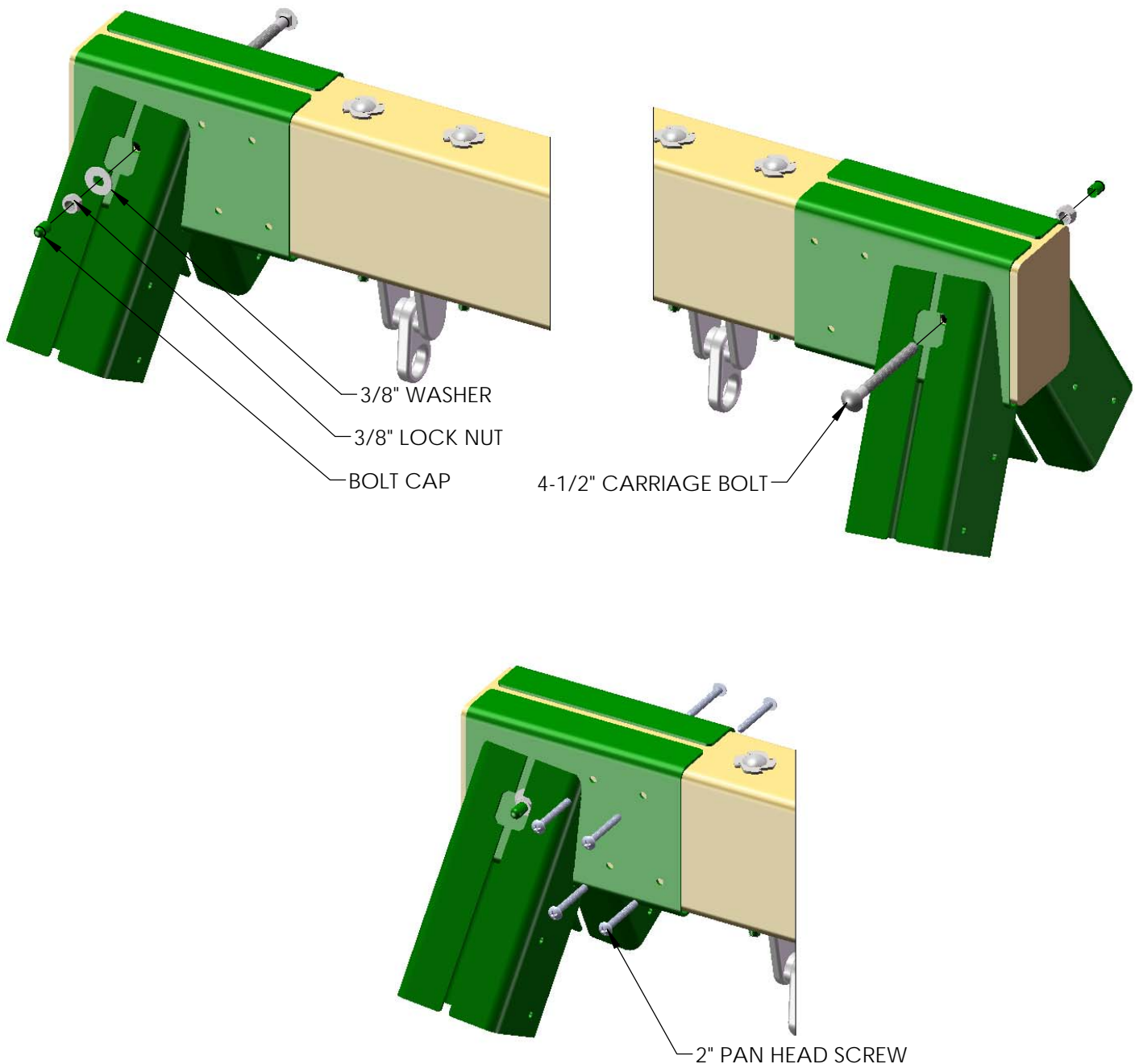

## STEP 3: SWING LEGS

- 1: FIND THE FOUR 4 X 4 X 96" SWING LEGS.
- 2: PLACE THE LEGS IN THE HOLES OF THE BRACKET AND ALLOW THE LEGS TO GO INTO THE HOLES UNTIL THEY STOP.
- 3: ONCE ALL FOUR LEGS ARE IN THE BRACKETS, ADJUST THE LEGS AS NECESSARY TO LEVEL THE SWING BEAM.
- 4: FASTEN THE LEGS TO THE SWING LEG BRACKET WITH 2" PAN HEAD SCREWS IN THE HOLES OF THE BRACKET.

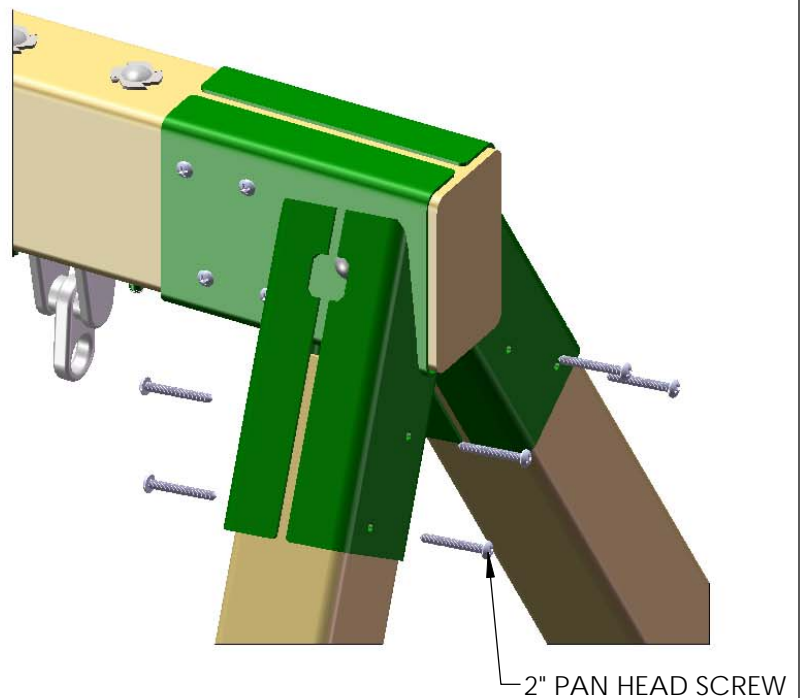
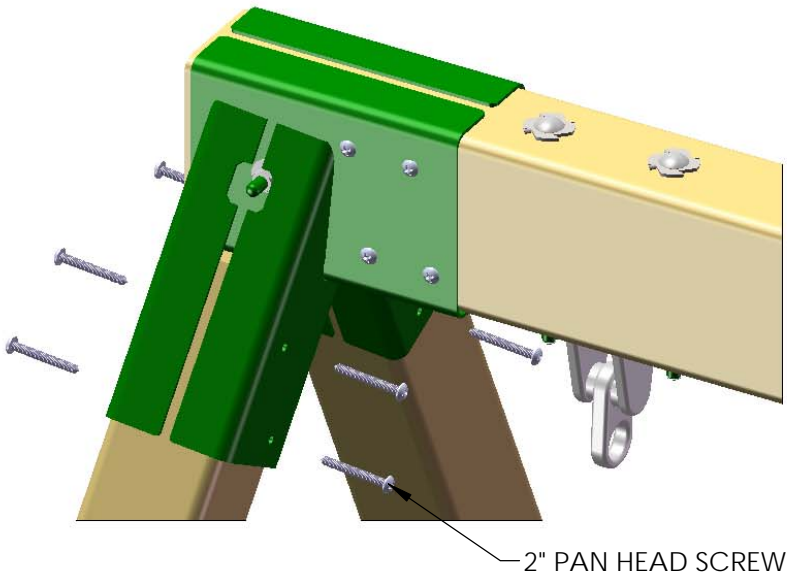

## STEP 4: SWING LEG CROSS-MEMBER

1: POSITION THE 2 X 4 X 58" SWING LEG CROSS-MEMBER AGAINST THE SWING BEAM LEGS.

2: LEVEL CROSS-MEMBER, AND FASTEN TO THE SWING LEGS WITH 3/8 X 3-1/2" LAG SCREWS AND 3/8" WASHERS.

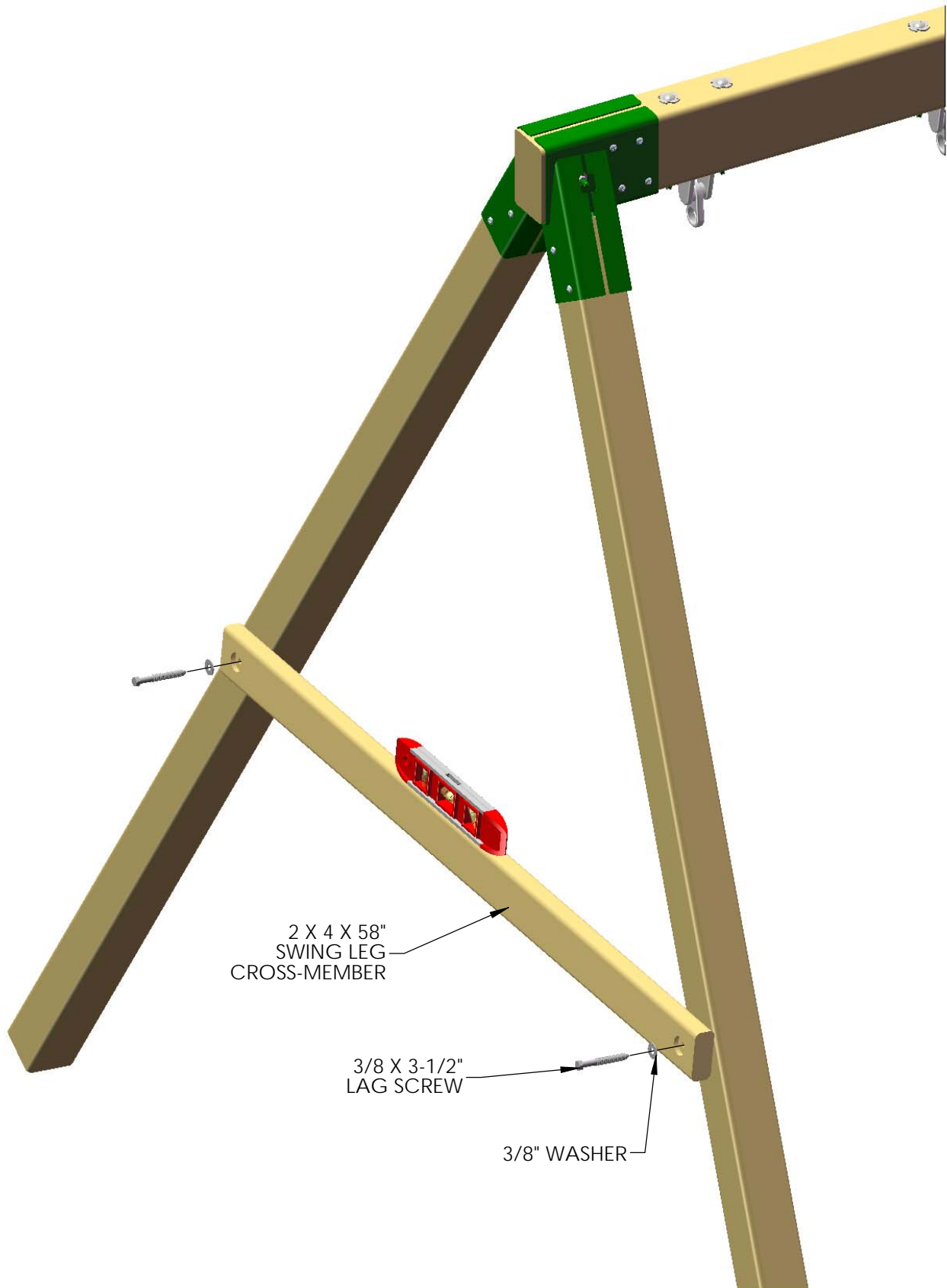

## STEP 5: HANGING THE SWINGS

- 1: CLIP EACH OF THE SPRING CLIPS ONTO THE IRON DUCTILE SWING HANGERS, THEN CLIP ONTO THE SWING CHAINS.
- 2: USE THE CLIPS TO ADJUST THE HEIGHT OF THE SWING BY CLIPPING ON HIGHER OR LOWER LINKS.
- 3: COUNT BACK THE SAME NUMBER OF LINKS ON THE OPPOSITE SIDE TO ENSURE THAT THE SWING IS LEVEL, AND ADJUST TO FIT YOUR NEEDS.

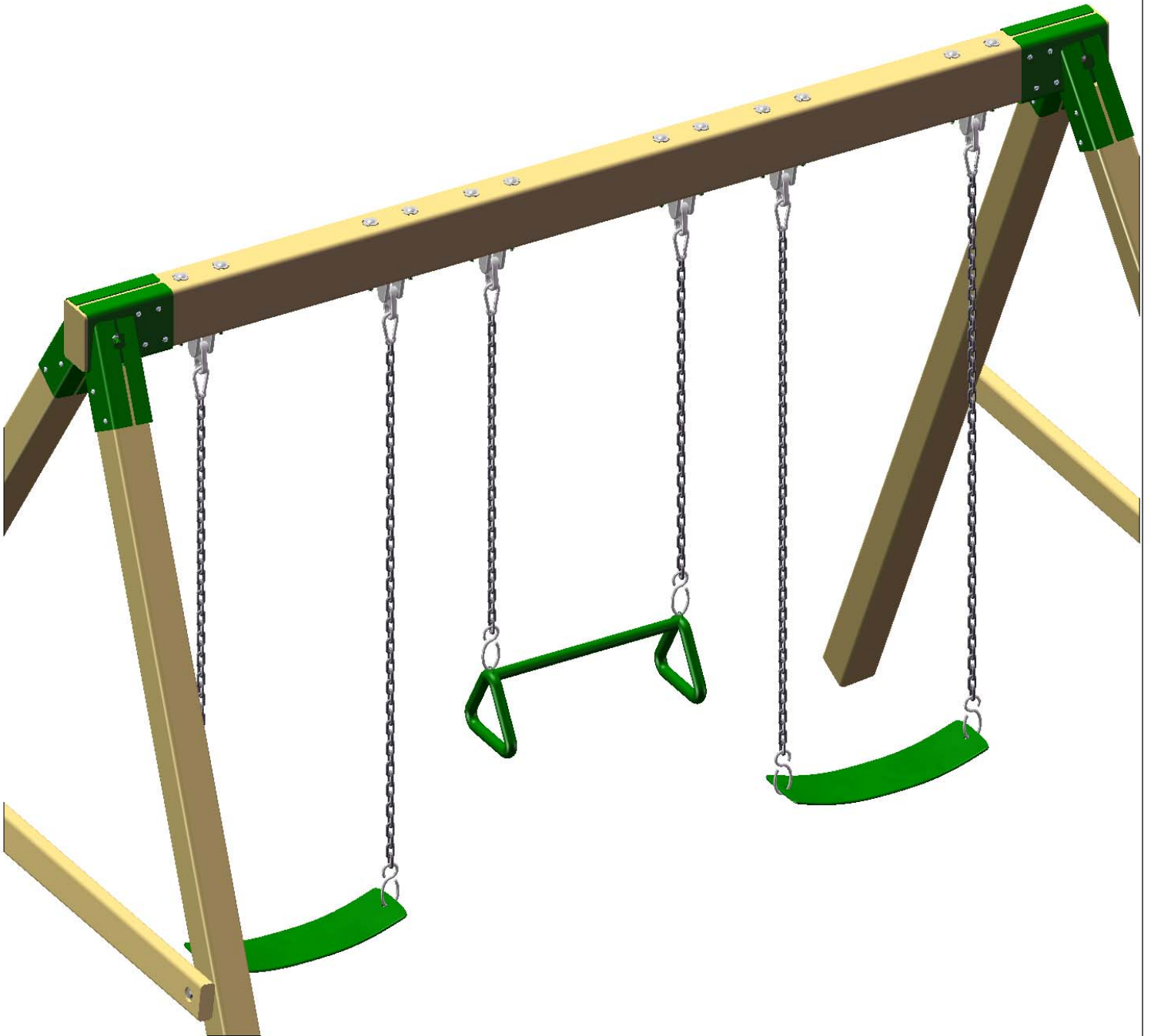

# WARRANTY REGISTRATION CARD – CONGO SWING STATION

Name: \_\_\_\_\_

Address: \_\_\_\_\_

City, State, Zip: \_\_\_\_\_

Email: \_\_\_\_\_

Date of Purchase: \_\_\_\_\_

Place of Purchase: \_\_\_\_\_

City, State, Zip: \_\_\_\_\_

Please, check the boxes below.

Your age?

- 18-25    26-30    31-35    36-40    41-45    46-50    51-55    56-60  
 61-65    66+

How old are your children?

- 2-3    4-5    6-7    8+

How would you rate the quality of our product?

- Excellent    Above average    Average    Below average    Poor

Would you recommend this product?

- Yes    No

Comments:

\_\_\_\_\_  
\_\_\_\_\_  
\_\_\_\_\_  
\_\_\_\_\_  
\_\_\_\_\_

Thank you for registering with gorilla playsets™! The information you provided will be kept confidential and will ONLY be used to better serve our customers. Remove this page from the manual and mail to the address below.

Thank you from everyone here at gorilla playsets™!

Mail to:  
Gorilla Playsets  
190 Etowah Industrial Court  
Canton, GA 30114

or fax:  
(678) 880-3329