



Caribou

Model: 1200

(BOXES: 1200-1, 1200-2 &
SLIDE BOX)

Copyright © 2014 Gorilla Playsets
All Rights Reserved

190 Etowah Industrial Court
Canton, GA 30114

www.gorillaplaysets.com

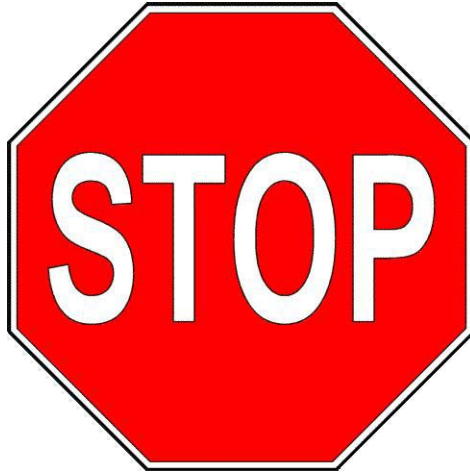

Please inspect and inventory all parts immediately upon accepting delivery. Use the inventory pages in the manual to make sure you have received all necessary parts. The quickest method to get any parts that are missing or damaged is to use our “Quick Response Center” located at:

www.gorillaplaysets.com/support

DO NOT RETURN THIS PRODUCT TO THE RETAILER OR CONTACT THE RETAILER DIRECTLY. THE RETAILER DOES NOT STOCK COMPONENTS.

PLEASE RETAIN ALL INSTRUCTIONS FOR FUTURE REFERENCE. KEEP THEM IN A SAFE PLACE WHERE YOU CAN REFER TO THEM AS NEEDED. CHECK FOR REVISED INSTRUCTIONS AT:

www.gorillaplaysets.com/manuals

GORILLA PLAYSETS WARRANTY – 2014

Gorilla Playsets® (“Gorilla”) warrants its play sets to be free from defects in workmanship and materials, under normal use and conditions, for 10 years for above ground structural wood components and for one year for all other components (e.g., swings, hardware, plastics, tarps, rope ladder, etc.).

Gorilla warrants all remaining products, including but not limited to its , Free Standing Swing Set, Free Standing Tire Swing, See-Saw, Children’s Picnic Table with Umbrella, Play-Zee-Bo™, Cedar Toy Chest and spring riders to be free from defects in workmanship and materials, under normal use and conditions, for a period of 1 year. The Krazy Clubhouse is warranted for a period of 6 months.

Cosmetic imperfections and natural tendencies of wood such as peeling, splintering, warping, seasonal checking or cracking, knots or knot holes, etc. are normal characteristics of all outdoor wooden play equipment and are not covered by this warranty.

Wood rot or decay that develops because the product was installed in an area with poor drainage is not covered under this warranty. Lumber that has been damaged by wood boring bees, or conditions that develop as a result of faulty or improper installation of the product, are not covered by this warranty. Fading of stain, discoloration or mold on any wood part or accessory is not covered by this warranty. Cracks in plastic components, surface rust on hardware and chips on powder coated materials are not considered defects in material as long as they do not affect the functionality or structural integrity of the part or component.

It is the owner’s responsibility to maintain the swing set. **This includes but is not limited to staining and sealing the lumber as needed and regular inspection to be sure all hardware is tight.** Instructions for proper maintenance can be found on Gorilla’s website. Imperfections or conditions that develop because of a failure to properly maintain the swing set are not covered by this warranty.

Gorilla will, at its discretion, replace any above ground part within the stated warranty period that is defective in workmanship or materials. This decision is subject to verification of the defect, which, at Gorilla’s discretion, may be accomplished by submitting photographs or by delivery of the defective part to Gorilla Playsets • 190 Etowah Industrial Ct. • Canton, GA 30114 • 1-800-882-0272 Monday to Friday 9AM-5PM EST. Any warranty claim must include proof of purchase, including the date of purchase. In addition, within the first 30 days from the date of purchase, Gorilla will replace any parts discovered to be missing from or damaged in the original packaging.

This warranty is valid only if the product is used for the purpose for which it was designed and installed at a residential, single-family dwelling. This warranty is void if the product is used in a commercial, institutional or multi-family setting. **This warranty does not cover normal wear and tear or (a) products that have been damaged by acts of God and/or nature, negligence, misuse or accident; (b) products that have been modified or repaired by unauthorized persons; (c) the cost of labor; or (d) the cost of shipping any replacement product or part.**

GORILLA DISCLAIMS ALL OTHER REPRESENTATIONS AND WARRANTIES OF ANY KIND, EXPRESSED, IMPLIED, STATUTORY OR OTHERWISE, INCLUDING THE IMPLIED WARRANTIES OF MERCHANTABILITY AND FITNESS FOR A PARTICULAR PURPOSE. GORILLA WILL NOT BE LIABLE FOR ANY INCIDENTAL OR CONSEQUENTIAL DAMAGES. This warranty is non-transferable and does not extend to the owners of the product subsequent to the original purchaser. Some states do not allow limitations on implied warranties or exclusion of incidental or consequential damages, so these restrictions may not be applicable to you. This warranty gives you specific legal rights. You may also have other rights which vary from state to state.

IMPORTANT SAFETY GUIDELINES

This product is recommended for use by children ages 3-11. This product is intended for residential use only and not intended for use in any public setting. A safety surface such as mulch or recycled tire should be used under the play set to prevent injury from falls. Also a 6 foot safety zone should be used around the entire play set.

As with any home project, good judgment and respect for power tools will greatly reduce the risk of injury. Gorilla recommends you follow all tool manufacturers' safety guidelines. Always wear eye protection and safety gloves to prevent injury. In several phases of construction two people may be required for lifting and securing of lumber. While the play set is being constructed, please keep children off the equipment until the project is complete. Bolts and screw heads should be checked regularly for tightness. The ground ladder, rope ladder, slide, swings and other areas where children spend a majority of their playtime should be checked more frequently.

Gorilla shall not be liable for incidental, indirect or consequential damages or injuries that result from building and/or playing on our play sets. Adult supervision is recommended anytime a play set is being used.

WEIGHT LIMITS FOR GORILLA PLAYSETS

- FORT PLATFORMS: 800 LBS. TOTAL WEIGHT
- SWING BELT: 225 LBS.
- GLIDER SWINGS: 70 LBS. PER CHILD. UP TO 140 LBS. TOTAL WEIGHT.
- TRAPEZE: 125 LBS.
- FULL BUCKET SWING/ HALF BUCKET SWING: 50 LBS.
- HEAVY DUTY TODDLER BUCKET SWING: 85 LBS.
- INFANT SWING: 35 LBS.
- TIRE SWING: 125 LBS. TOTAL WEIGHT
- ROPE LADDER: 75 LBS.
- ROCK WALL: 150 LBS.
- CLIMBING RAMP: 150 LBS.
- MONKEY BARS: 175 LBS.
- ALL SLIDES: 150 LBS.

Gorilla recommends that the weight limits for all components must not be exceeded. Failure to adhere to these and other safety guidelines could result in damage to the play set and injury to the users.

WARRANTY REGISTRATION

- CARIBOU -

Gorilla Playsets manufactures the finest quality products that are designed for outstanding strength and durability. We back our products with an unparalleled warranty. In the unlikely event that you will need to contact us about covered repairs, we must have a valid Warranty Registration on file.

3 EASY WAYS TO REGISTER	
OPTION 1	Fax this completed form to: (678) 880-3329 OR Mail this completed form to: Gorilla Playsets 190 Etowah Industrial Court Canton, GA 30114
OPTION 2	Complete the online registration form at: http://www.gorillaplaysets.com/register
OPTION 3	Scan this QR Code with your smart phone to complete the form using your phone 

Where did you buy this product?:

Date of Purchase

Place of Purchase

Your registration information:

Name: _____ Email: _____

Address: _____

Street

City

State

Zip

Please select your age? 18-30 31-40 41-50 51+

How old are your children? 2-3 4-5 6-7 8+

How would you rate the quality of this product?
 ★★★★★ Excellent
 ★★★★ Above Average
 ★★★ Average
 ★★ Below Average
 ★ Poor

Would you recommend this product to friends & family? Yes No

Comments: _____

IMPORTANT – PLEASE READ

As fresh lumber acclimates to its new environment, the natural tendencies of the tree can show itself in the form of checks, or “cracks” in the lumber. In almost all cases this is normal and it will not affect the structural integrity of your play set.

Cosmetic defects that do not affect the structural integrity of the product, or natural defects of wood such as warping, checking or any other physical properties of wood that do not present a safety hazard, are not covered by this warranty. Defects that develop because the product is exposed to extreme climate conditions or woodboring insects are not covered by this warranty. Defects that develop as a result of faulty or improper installation of the product are also not covered by this warranty.

Most cracks are not warrantable, however if you believe that the integrity of your play set is compromised by this natural occurrence, please follow the warranty claim procedure found at www.gorillaplaysets.com. Click on the “Customer Care” tab on the left hand side of the page, then click on “Warranty Claim” and follow the directions.

KEEPING YOUR PLAYSET LIKE NEW

LUBRICATE:

- Spray swing hangers with Pam, Mazola or olive oil to stop squeaking.
- Do not use petroleum based products such as WD-40 or motor oil.
- To speed up the slide wipe center of slide ONLY with wax paper every 2 - 3 weeks.

TIGHTEN:

- Check and tighten hex/carriage bolts within first 60 days and then twice annually.
- Check lag screws for tightness before each season and then once during the season for tightness. Tighten lag screws as required.

SEAL:

- Apply an oil based sealer or preservative within 90 days, then every 2 - 3 years. You may need to power wash the unit before sealer application on year two.

INSECTS:

- To repel yellow jackets and wasps, using a cloth, coat all interior 90 degree corners with liquid dish soap underneath the play set deck. This will make wasps sick when they attempt to build a nest. Avoid using insecticides.



Model: 1200

(BOXES: 1200-1, 1200-2 &
SLIDE BOX)

REV: 4.15.2013

TABLE OF CONTENTS

Safety Guidelines.....	Pages 3-6
Leveling fort, General Information, Definitions.....	Pages 6-8
How to Install T-nuts, Board Identification, Pre-drill Lag Screw Directions and Swing Beam Loading.....	Pages 9-13
Site Plan, Required Tool List and Kit Contents.....	Pages 14-15
Hardware, Lumber and Accessory Checklists.....	Pages 16-27
Framing Play Set.....	Steps 1-9
Attaching Bottom Panel Boards and Deck.....	Steps 10-13
Rock Wall Assembly and Installation.....	Steps 14-21
Ladder Assembly and Installation.....	Steps 22-23
Panel Slats.....	Step 24
Roof Support Assemblies.....	Steps 25-26
Swing Beam Assembly.....	Steps 27-34
Roof Assembly.....	Steps 35-40
Picnic Table Assembly and Installation.....	Steps 41-43
Rope Ladder Assembly.....	Step 44
Installing Slide.....	Step 45
Telescope and Rock Wall Rope.....	Steps 46-47
Tic Tac Toe Assembly and Installation.....	Steps 48-49
Safety Handles, Flag Kit, Hanging Swings and Ground Stakes/Name Plate.....	Steps 50-53
Safety Board.....	Step 54
Steering Wheel.....	Step 55

**PLEASE READ OWNER'S MANUAL CAREFULLY
BEFORE STARTING ASSEMBLY!**

Safety and Maintenance Tips for Your New Play Set:

NOTE: Your children's safety is our #1 concern. Observing the following statements and warnings reduces the likelihood of serious or fatal injury. Please review these safety rules regularly with your children.

- This play set is designed for the use of 4 occupants who have a combined weight not exceeding 800 pounds on the elevated floor, 3 occupants who have a combined weight of 425 pounds on the swing area, for a total Unit capacity of 7 occupants who have a combined weight of 1225. (This weight does not include any picnic table area(s).)
- On-site adult supervision is required.
- Teach children not to walk close to, in front of, behind, or between moving swings or other moving playground equipment.
- Teach children to sit in and never stand on swings
- Teach children not to twist the chains and ropes and not to loop them over the swing beam, since this may reduce the strength of the chain or rope.
- Teach children not to jump from swings or other playground equipment in motion.
- Teach children not to push empty seats. The seat may hit them and cause serious injury.
- Teach children to sit in the center of the swings with their full weight on the seats.
- Teach children not to use the equipment in a manner other than intended.
- Teach children to always go down slides feet first. Never slide headfirst.
- Teach children to look before they slide to make sure no one is at the bottom.
- Teach children to never run up a slide, as this increases their chances of falling.
- The parents should have the children dress appropriately with well-fitting shoes. Loose clothing such as scarves and ponchos should not be worn. Always take off, tie up or tuck in cords and drawstrings on children's clothing. These things can get caught on playground equipment and strangle a child.
- Teach children not to climb when the equipment is wet.
- Teach children to never jump from a fort deck. They should always use the ladder, ramp or slide.
- Teach children to never crawl or walk across the top of monkey bars.
- Teach children to never crawl on top of a fort roof.
- Verify that any suspended climbing ropes, chains, or cables are secured at both ends and that they cannot be looped around an adult hand.
- Teach children not to attach items to the playground equipment that are not specifically designed for use with the equipment, such as, but not limited to, jump ropes, clothesline, pet leashes, cables and chain as they may cause a strangulation hazard.
- Teach children to never wrap their legs around swing chain.
- Teach children to never slide down the swing chain.
- Teach children to remove their bike or other sports helmet before playing on the playground equipment.
- Teach children to NEVER look at the sun or other bright light through any accessory such as but not limited to a telescope, periscope or binoculars.

WARNING: Children must NOT use this play set until it has been completely assembled and inspected by an adult to insure it has been properly installed and the swing beam legs are anchored.

Safety and Maintenance Tips for Your New Play Set: (continued)

Playgrounds should be inspected on a regular basis. If any of the following conditions are noted, they should be removed, corrected, or repaired immediately to prevent injuries.

- Hardware that is loose, worn or that has protrusions or projections.
- Exposed equipment footings.
- Scattered debris, litter, rocks, or tree roots.
- Splinters, large cracks, and decayed wood components.
- Deterioration and corrosion on structural components, which connect to the ground.
- Missing or damaged equipment components, such as handholds, guardrails, swing seats.
- Check all nuts and bolts twice monthly during the usage season and tighten as required. (But not so tight that you crack the wood) We recommend you check the swing beam and hardware often due to wood expansion and contraction. It is particularly important that this procedure be followed at the beginning of each season.
- Remove plastic swing seats and take indoors or do not use when the temperature drops below 32°F. Reinstall swings and other swing equipment at the beginning of the usage season.
- Oil all metallic moving parts monthly during the usage period.
- Check all coverings for bolts and sharp edges twice monthly during usage season to be certain they are in place. Replace when necessary. It is especially important to do this at the beginning of each new season.
- Check swing seats, ropes, cables and chains monthly during usage season for evidence of deterioration. Replacement should be made of any swing seat that has developed cracks in the plastic seats. Ropes, cables and chains should be removed and replaced if excessive wear is found. Contact us for warranted replacement parts.
- For rusted areas on metallic members such as monkey bars, hand supports brackets, etc.; sand and repaint, using a non lead-based paint meeting the requirements of Title 16 C.F.R. Part 1303. These requirements are available at: <http://www.cpsc.gov/>
- Inspect wood parts monthly. The grain of the wood sometimes will lift in the dry season causing splinters to appear. Light sanding may be necessary to maintain a safe playing environment. If you are treating your play set with stain regularly, it will help prevent severe checking/splitting and other weather damage.
- Once or twice a year, depending on your climate conditions, you must apply some type of protection (sealant) to the wood of your unit. Prior to the application of sealant, lightly sand any “rough” spots on your set. Please note this is a requirement of your warranty.
- Creating and maintaining the play set on a level location is very important. As your children play, your play set will slowly dig its way into the soil, and it is very important that it settles evenly. Make sure the play set is level and true once each year or at the beginning of each play season.
- Twice a month during the usage season rake the playground protective surfacing materials to prevent compaction and maintain appropriate depths. Replace the protective surfacing materials as required.
- Disposal Instructions: When the play set is no longer desired, it should be disassembled and disposed of in such away that no unreasonable hazards will exist at the time the play set is discarded.

Play Set Surfacing Recommendations:

Below are some of the recommendations that the U.S. Consumer Product Safety Commission (CPSC) offers from its Handbook for Public Playground Safety. The guide can be downloaded in full at www.cpsc.gov/cpscpub/pubs/325.pdf

1. Protective Surfacing - Since almost 60% of all injuries are caused by falls to the ground, protective surfacing under and around all playground equipment is the most critical safety factor on playgrounds.

Certain manufactured synthetic surfaces also are acceptable; however, test data on shock absorbing performance should be requested from the manufacturer.

Asphalt and concrete are unacceptable. They do not have any shock absorbing properties. Similarly, grass and turf should not be used. Their ability to absorb shock during a fall can be reduced considerably through wear and environmental conditions.

Certain loose-fill surfacing materials are acceptable. Surfacing materials are acceptable, such as the types and depths shown in the table.

Fall Heights and Materials

Type Of Material	6 in. depth	9 in. depth	12 in. depth
Double-Shredded bark mulch	6' Fall Height	10' Fall Height	11' Fall Height
Wood Chips	6' Fall Height	7' Fall Height	12' Fall Height
Fine Sand	5' Fall Height	5' Fall Height	9' Fall Height
Shredded Tires*	10-12' Fall Height	N/A	N/A
Fine Gravel	6' Fall Height	7' Fall Height	10' Fall Height

*This data is from tests conducted by independent testing laboratories on a 6-inch depth of uncompressed shredded tire samples produced by four manufacturers. The tests reported critical heights, which varied from 10 feet to greater than 12 feet. It is recommended that persons seeking to install shredded tires as a protective surface request test data from the supplier showing the critical height of the material when it was tested in accordance with ASTM F1292.

It should be recognized that all injuries due to falls cannot be prevented no matter what surfacing material is used.

2. Fall Zones - A fall zone, covered with a protective surfacing material, is essential under and around equipment where a child might fall. This area should be free of other equipment and obstacles onto which a child might fall. Stationary climbing equipment and slides should have a fall zone extending a Minimum of 6' in all directions from the perimeter of the equipment.

Swings should have a fall zone extending a minimum of 6' from the outer edge of the support structure on each side. The fall zone in front and back of the swing should extend out a minimum distance of twice the height of the swing as measured from the ground to the top of the swing support structure.

LEVELING YOUR FORT DURING ASSEMBLY

- Complete the steps which will be the basic frame of the fort. {i.e. four corner posts with base (sand box boards) and deck supports}
- Position in the most level area chosen for the play set, keeping in mind the location and size of the swing beam, ladder, slides, etc. that extend off the fort.
- Once the frame is in the final position, check for vertical and horizontal levelness to determine which side(s) will need to be dug into the ground to level the play set.
- With a shovel, score the ground around the outside edges of the sandbox boards on the 'high' side of the fort. This is the area that will be dug in. Make sure to score deep enough; the scored lines will be your digging template.
- Push the frame off and away from the scored area, far enough to dig and remove dirt to reach the appropriate depth.
- Dig a channel along the scored line(s) for the base of the fort (corner post and sandbox boards) to rest into. Dig the channel(s) to the same level depth. The bottom of the channel(s) should be level to each other so your frame doesn't teeter or rock because the channel(s) are uneven.
- Once you have removed enough grass and dirt, slide/push the frame into the channel(s). Place a level on the vertical and horizontal boards of the frame to determine if enough soil, or too much, was removed.
- Repeat this process until the basic frame is plumb and level and in its final position before completing the rest of the assembly.
- Measure to make sure fort is square.

Important: if you require a channel depth of more than 6", then we recommend you have your play set area professionally graded before completing assembly.

Example Play area:

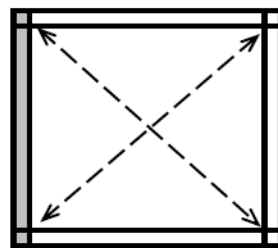
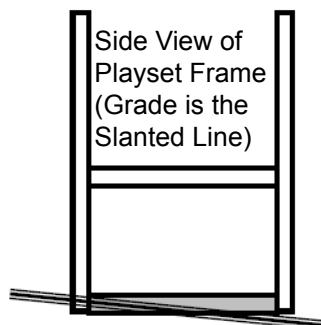

The diagonal measurements should be the same from corner post to corner post. If not, adjust corner posts so that the distance is equal.

■ = Area to be scored and channeled for levelness

General Info to Review Before Installation

- Depending on your experience, assembly of the playset can take as little as 6 hours up to 24 hours, depending on size, after inventory of parts; therefore, we recommend you set aside a full two days for assembly.
- Identify all of the parts for your play set. Empty each box and lay out boards so you can see each part. Your instruction book will have detailed drawings that will make it easy for you to recognize individual parts. Keep all hardware and metal parts separate from wooden pieces.
- After everything is laid out, check carefully to ensure all parts are present. Make sure there are no broken boards.
- Find an area to sort your hardware. It is best to open the hardware on a solid surface so that you do not lose any pieces in the grass. This will save time and familiarize you with all the different pieces in the hardware bag.
- Important note: Wood has some natural defects such as knots, surface cracks, etc... We reject parts that are structurally defective. We use a high quality lumber in our structures; however, you should inspect each part for splinters or rough spots and sand them smooth to prevent injury.
- After familiarizing yourself with all of the components, read all instructions thoroughly. Reading instructions after you have studied the parts will help you understand the installation process, and help to eliminate unnecessary mistakes.
- Pay close attention to the diameter and length of each bolt and screw.
- Never tighten hardware completely at first. It helps to have some adjustment for bolt alignment while you are attaching parts together. After everything is square, tighten each joint.
- After the main unit is assembled it is critical that the floor is level and square. If the main frame is not level, the walls and floor will be out of square.
- After you complete installation, make sure every bolt, screw, and nut is tight, and every board is secure. Wood will expand and contract with the seasons.
- Place the set on level ground, not less than 6 feet from any structure or obstruction such as a fence, garage, house, overhanging branches, laundry lines, or electrical wires.

This page is a list of definitions and explanations used throughout our instructions to aid you in the assembly of your play set.

Offset Holes- Throughout the installation procedures we will refer to parts with offset holes. This refers to the orientation of the holes on the board. An offset hole is one that is closer to one side than it is the other or in other words, it is not centered on the board. In the procedures you will be instructed to attach the boards with the holes offset up or with the holes offset down. This refers to which side of the board the hole/holes should be closer to. Offset holes up= hole/holes will be closer to the top of the board. Offset holes down= hole/holes will be closer to the bottom of the board. Note: some parts do not have offset holes, but instead the holes are on center. Therefore there will not be any reference on how to offset these parts.

EXAMPLE OF OFFSET HOLES UP



EXAMPLE OF OFFSET HOLES DOWN



Counter-sunk holes - Many of the parts that will be used have counter-sunk holes. A counter-sunk hole is one that surrounds one side of a through hole, but does not extend through the wood it's self. When using a counter-sunk hole the bolt will be inserted through the through hole and either the head of the bolt and washer or nut and washer will occupy the counter sunk hole.

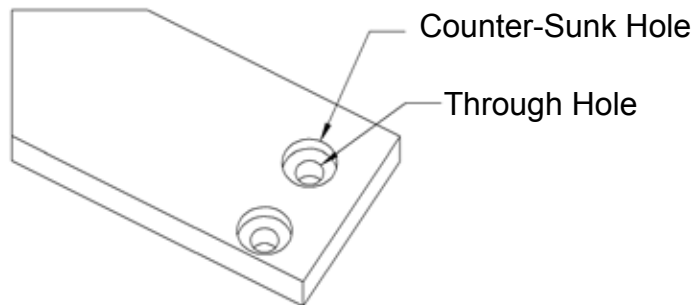

Lag Screws- Lag screws are used in the construction of our play sets to enhance the structural integrity of the unit. There will not be predrilled holes in the post for lag screw installation. Lag screws are self-tapping, though if you are using a manual socket wrench it may be advantageous to pre-drill a hole first. Instructions for this are provided on a separate page in the front of the manual. Be sure to tighten the lags completely when driving them in by hand. Power tools such as a heavy duty impact driver or large power drill should have enough torque to drive in the lag screws, but make sure not to over tighten as this can cause the threads to “strip out” in the post.

Common Installation Practice Installing T-nuts

When installing T-nuts into the wood, use a smooth faced hammer to set the face of the T-nut flush into the wood

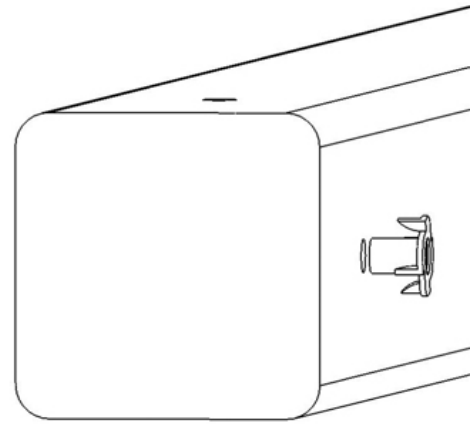
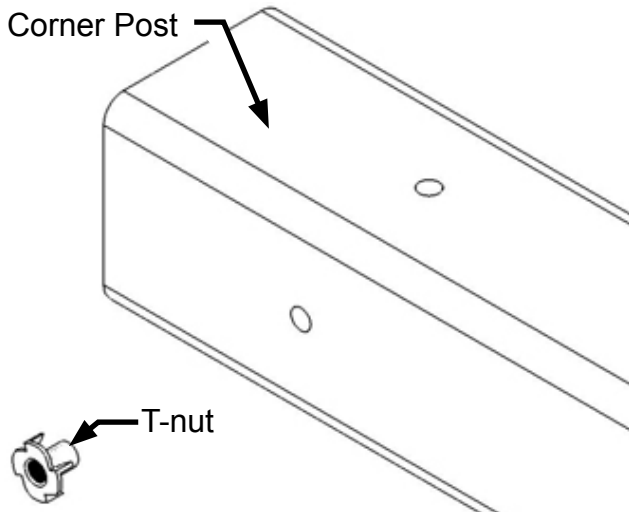

Insert the barrel of the T-nut into the predrilled hole. Using a smooth faced hammer, drive the T-nut until the face of the T-nut is flush to the wood.

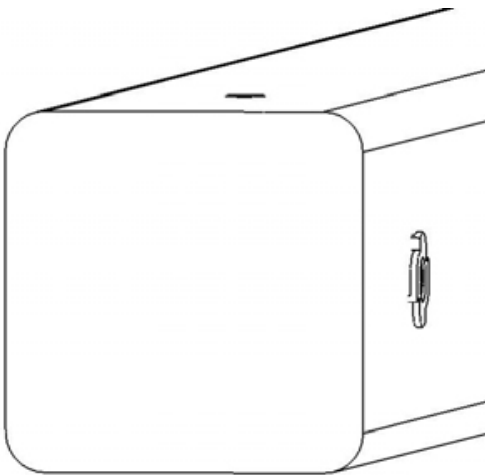

This picture shows the T-nut inserted and installed flush to the wood.

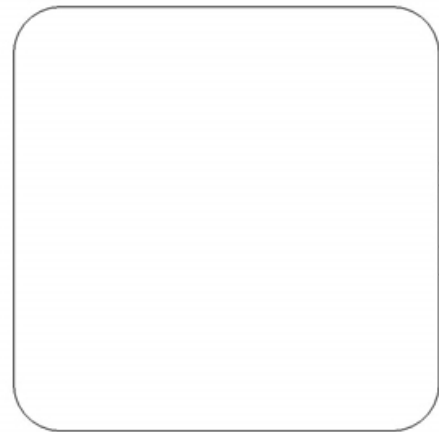

This picture shows an end view of the T-nut installed flush to the wood.

WARNING: DO NOT EMBED THE TOP OF THE T-NUT INTO THE FACE OF THE WOOD

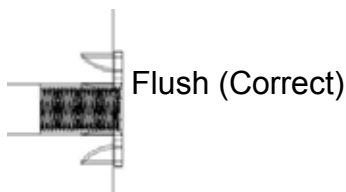

Cross Section end view, you are looking at an X-ray view of the post and T-nut. The barrel of the T-nut is in the corner post the line is the face of the wood.

HOW A T-NUT WORKS

THE FIRST STEP IN OUR ASSEMBLY INSTRUCTIONS IS TO INSERT T-NUTS INTO THE CORNER POSTS. A T-NUT IS A FASTENER WHICH IS THREADED ON THE INSIDE AND IT FUNCTIONS JUST LIKE A STANDARD HEX NUT. YOU INSERT THE T-NUTS INTO THE PREDRILLED HOLES IN THE CORNER POSTS.

THE T-NUT HAS A BARREL SHAPED END WHICH GOES INTO THE HOLE IN THE CORNER POST. THE T-NUT ALSO HAS AN FLANGE SHAPED END WITH TEETH. THE TEETH PENETRATE INTO THE CORNER POST WOOD TO PREVENT THE T-NUT FROM SPINNING WHEN YOU TIGHTEN THE HEX HEAD BOLT.

SHOWN BELOW YOU WILL SEE THE T-NUT IS HAMMERED INTO THE CORNER POST ON THE BACK SIDE. THE BOARD IS BEING ATTACHED ON THE FRONT SIDE OF THE CORNER POST.

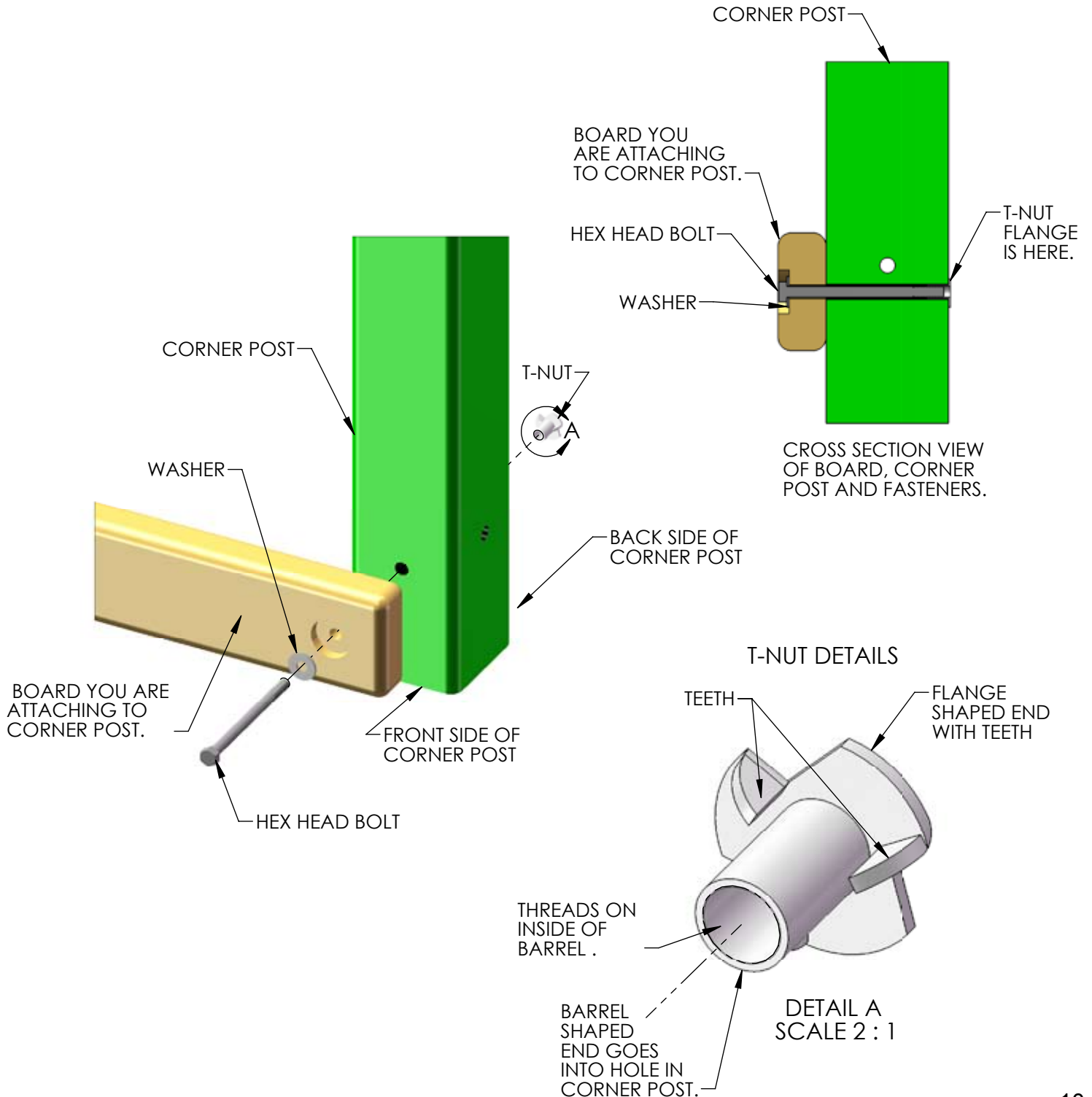

BOARD IDENTIFICATION

1. On the end of each board there should be a small white tag that is stapled into place.
2. This white identification tag displays the thickness, width, length and an abbreviated description of the part.

Example: a tag reads "2-4-3600-BPB"

- The 2 is the thickness of the board. "Nominal Lumber" at a home center will measure 1-1/2" for the thickness. We "remill" that lumber to 1-3/8" thick.
- The 4 is the width of the board. "Nominal Lumber" at a home center will measure 3-1/2" for the width. We "remill" that lumber to 3-3/8" wide.
Note: sometimes the width will be smaller than 3-3/8" because:
A) We need the width of the part to fit into a certain area of the play set.
B) We need the designation to be simple.
- The 3600 is the length of the board. It means the board is 36 inches long. If the code were 3625 then the board is 36-1/4" in length.
- The "BPB" abbreviation stands for "Bottom Panel Board". The wood part bill of materials in the instructions has a description which will match the abbreviation closely.
- In the event that there is no tag on a wood part measure the part then:
A) Use the measurements and compare them to the wood list at the front of the instructions to identify it.
B) Look at the holes on the wood part and compare them to the pictures in the wood list.
C) Look to see if the holes are centered or if they are offset up or offset down.
This should help you identify any parts that have missing tags. In the event that you cannot identify a board please email us for assistance.

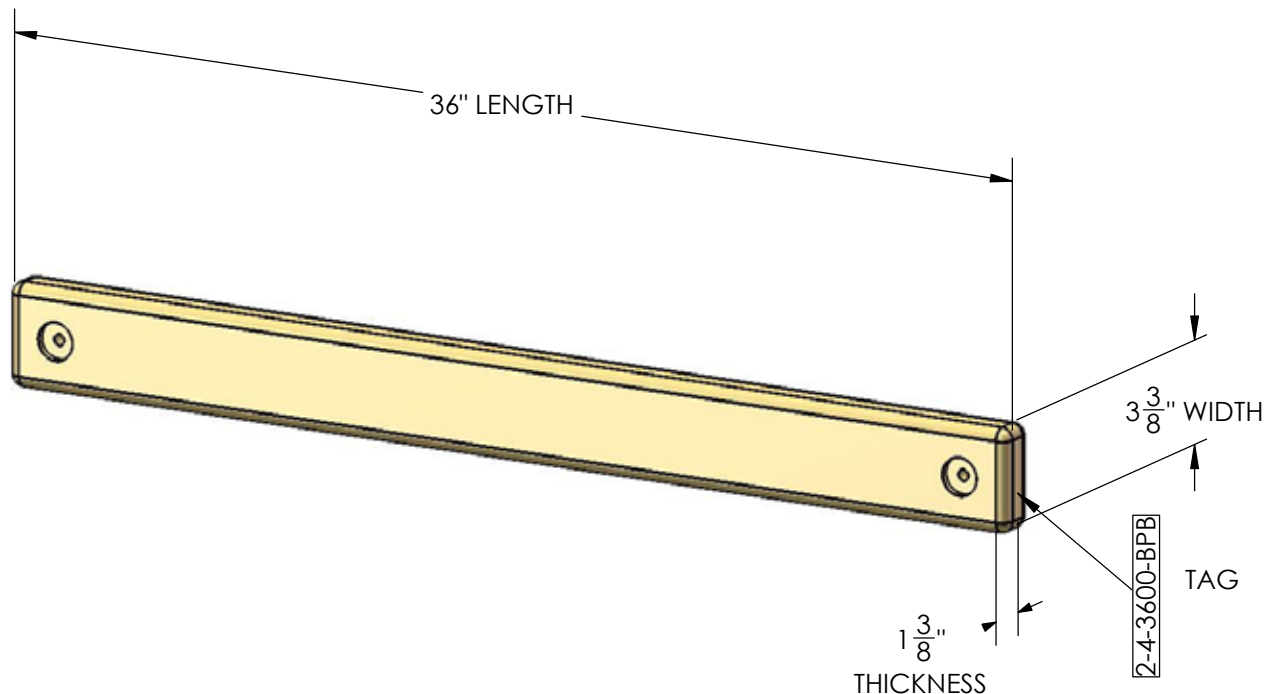

PRE-DRILL LAG SCREW DIRECTIONS

Pre-drilling holes for lag screws will make it easier to drive the screws in by hand. "Jobber" length drill bits are available in sizes that are longer than standard drill bits and those are ideal for the job. When using the drill bit you will have to "spot" drill the post and then remove the board you are attaching to finish drilling the hole.

Pay attention to the *DIAMETER* of the lag screw you are installing. Your playset may come with two different diameter lag screws. Each diameter will require a different size drill bit. When installing lag screws **DO NOT OVERTIGHTEN.**

LAG SCREW DIAMETER	DRILL BIT SIZE
5/16" DIAMETER	9/64"
3/8" DIAMETER	11/64"

Example: 3/8" diameter x 3-1/2" lag screw

This would be like the 2 x 4 board installation shown below. Place the board into position. Spot Drill through the holes in the 2 x 4 board into the corner posts with an 11/64" drill bit. Remove the 2 x 4 board. Continue to drill the holes to a total depth of 2-5/16" as shown at the right. Install the 2 x 4 board.

Example 5/16" diameter x 3-1/2" lag screw

This would be like the 2 x 4 board installation shown below. Place the board into position. Spot Drill through the holes in the 2 x 4 board into the corner posts with an 9/64" drill bit. Remove the 2 x 4 board. Continue to drill the holes to a total depth of 2-5/16" as shown at the right. Install the 2 x 4 board.

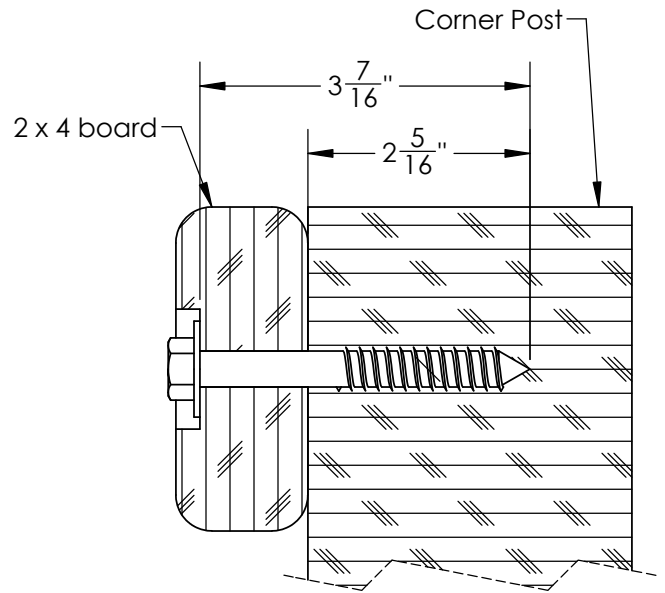

Example 3/8" diameter x 5" lag screw

This would be like the 4 x 4 board installation shown below. Place the board into position. Spot drill through the holes in the 4 x 4 board into the corner posts with an 11/64" drill bit. Remove the 4 x 4 board. Continue to drill the holes to a total depth of 2-13/16" as shown at the right. Install the 4 x 4 board.

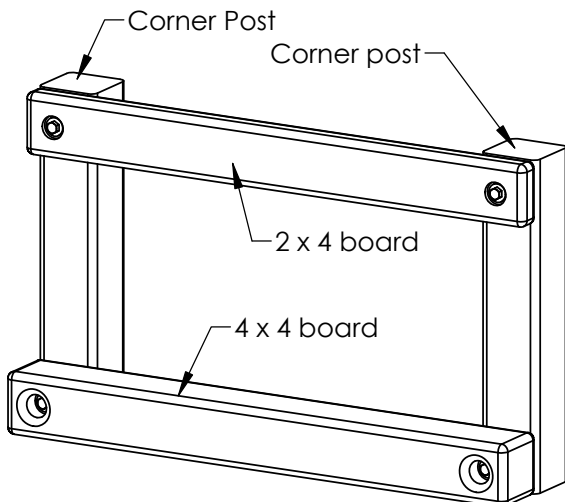
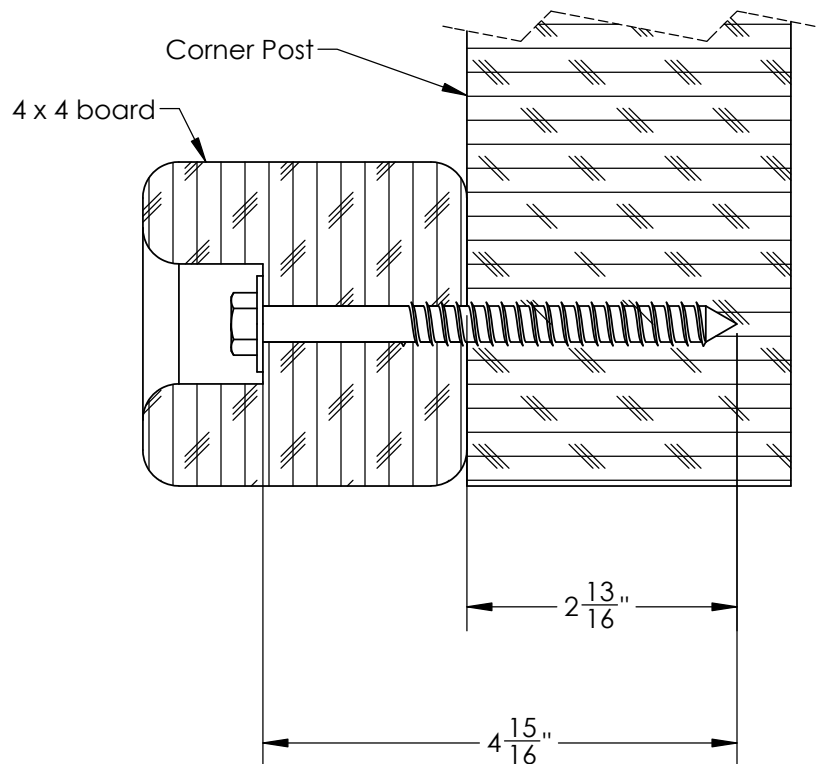

SWING BEAM LOADING

Weight Limits for Accessories:

The weight limit for a Swing Belt is 225 lbs. (Although 150lbs is the maximum recommended swinging weight capacity for the swing position.)

The weight limit for a Trapeze Bar is 125 lbs.

Maximum Allowable swinging weight for a three position swing:

- 1) The maximum allowable swinging weight at each Swing Belt position is 150 lbs.
- 2) The maximum allowable swinging weight at the Trapeze position is 125 lbs.
- 3) The MAXIMUM SWING BEAM LOAD IS 425 lbs.

MAXIMUM SWING BEAM LOAD IS 425 LBS.

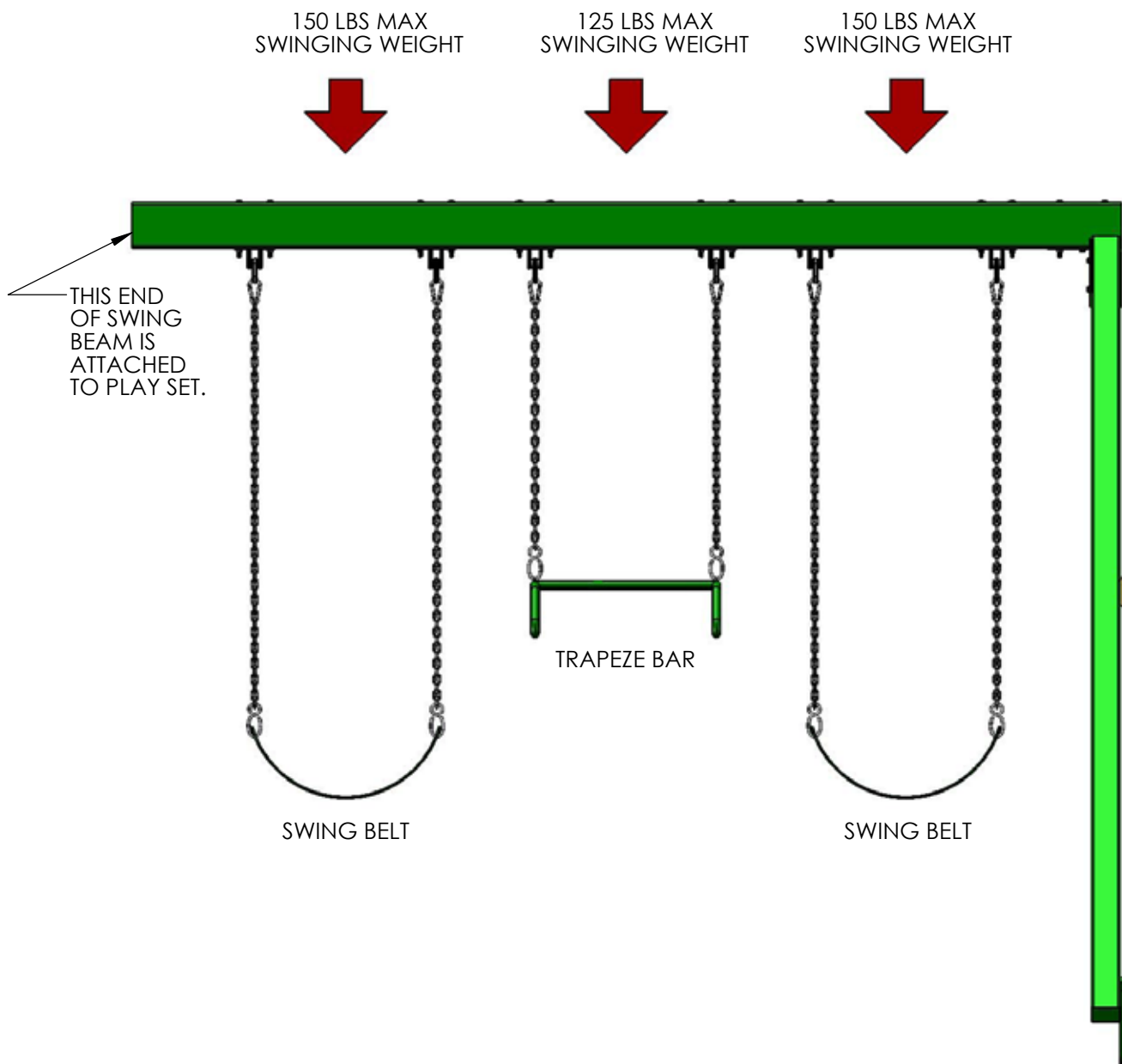

Please familiarize yourself with the manual, parts/components and general construction process of your new playset before getting started.

SITE PLAN:

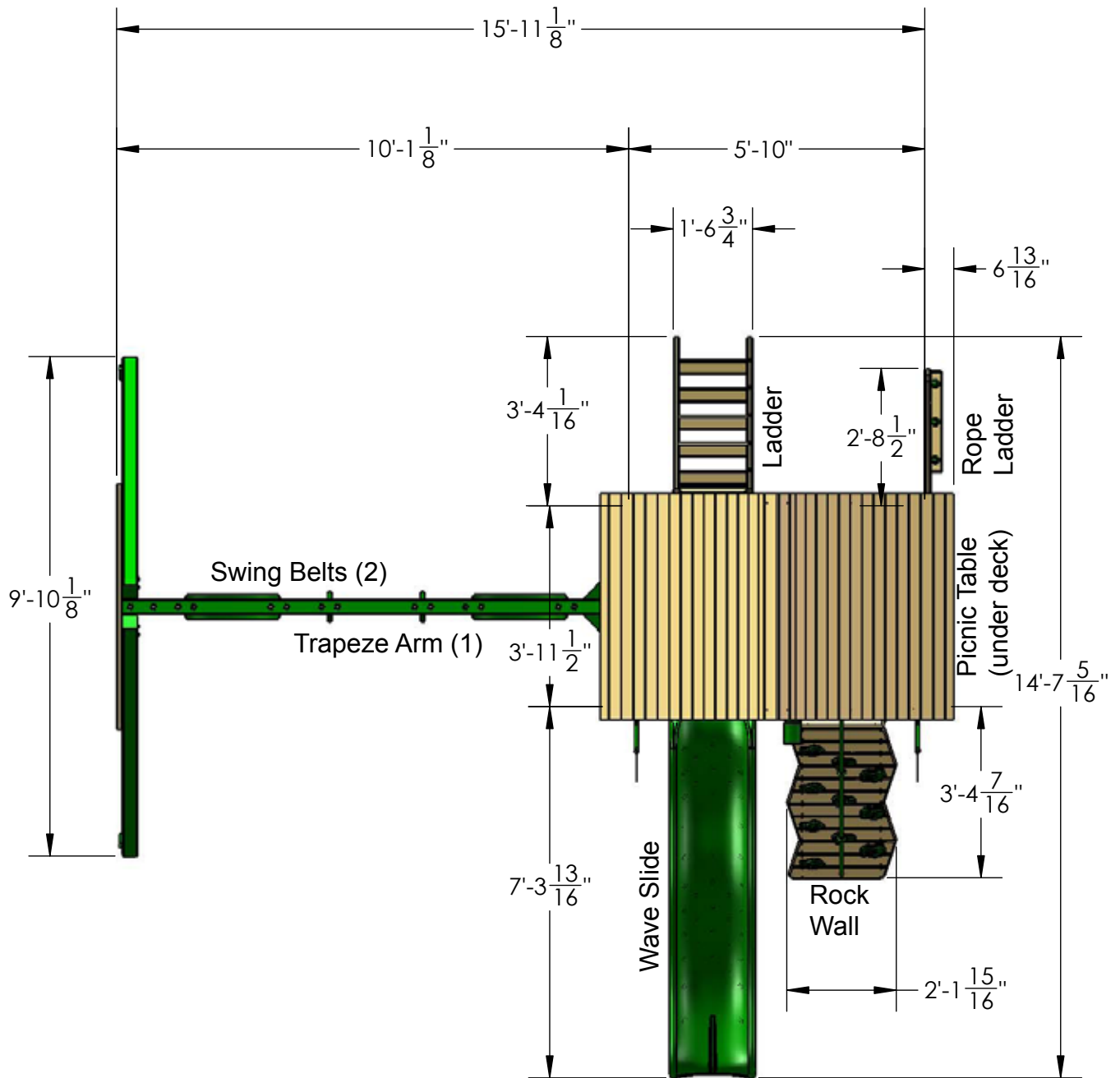

Playset height: 11 feet - 4-1/2 inches
 Deck height: 5 feet
 Swing beam height to top: 7 feet - 10-3/8 inches
 Approximate assembly time: 6 to 8 hours

(6) foot unobstructed safety perimeter around playset recommended

REQUIRED TOOL LIST:

- ___ Standard or Cordless Drill w/ Phillips Bit (#2 square bit provided)
- ___ Drill Bits 1/8", 3/16", 3/8", 9/64", 11/64".
- ___ 1/2" Wrench and Socket
- ___ 1/2" Deep Well Socket
- ___ 9/16" Deep Well Socket
- ___ 9/16" Wrench and Socket
- ___ Level
- ___ Tape Measure
- ___ Extension Cord (if using standard drill)
- ___ Hammer
- ___ Pencil
- ___ Locking Pliers (Vise Grips)
- ___ Shovel
- ___ Tape or Marker (Step 44)

KIT CONTENTS

Swings, Slides, Accessories:

- ___ (Qty) Description
- ___ (2) Swingbelts w/ Chains
- ___ (1) Trapeze Swing
- ___ (1) Tic Tac Toe
- ___ (1) Telescope
- ___ (1) Flag Kit (pair)
- ___ (1) Safety Handles (pair)
- ___ (1) Wave Slide
- ___ (1) Steering Wheel
- ___ (10) Rock Wall Grips (assorted colors)

Fort Hardware:

see following pages

Swing Beam Hardware:

see following pages

Wood Components:

see following pages

11-0029
 1200 HARDWARE
 12/4/2012
 REV B. J.H.
 PAGE 1 OF 2

5/16" X 3-1/2"
 HEX LAG
 SCREW
 QTY: 30

3/8 X 3-1/2"
 HEX LAG SCREW
 QTY: 12

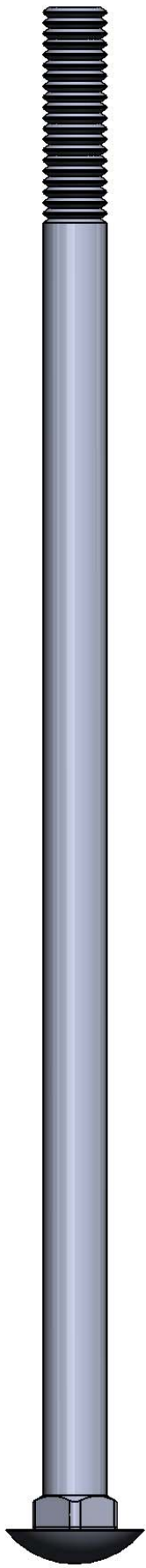

3/8 x 9"
 CARRIAGE BOLT
 QTY: 1

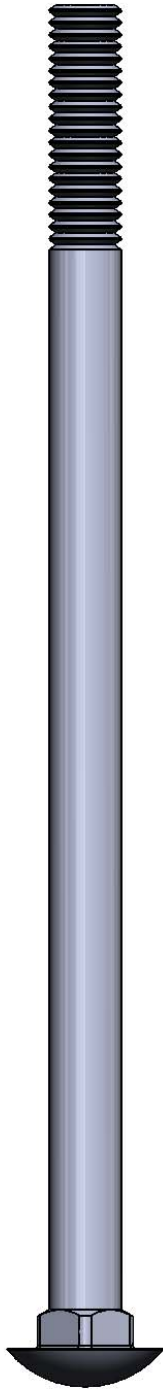

3/8 x 7"
 CARRIAGE BOLT
 QTY: 14

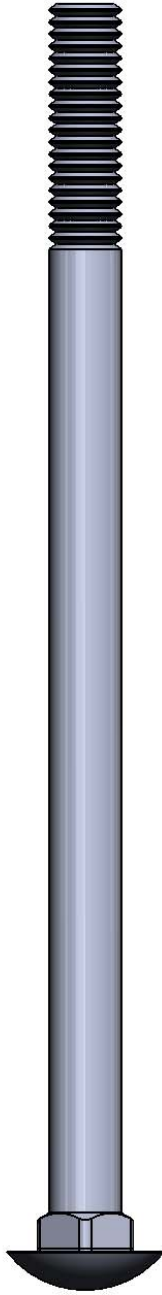

3/8 x 6-1/2"
 CARRIAGE BOLT
 QTY: 2

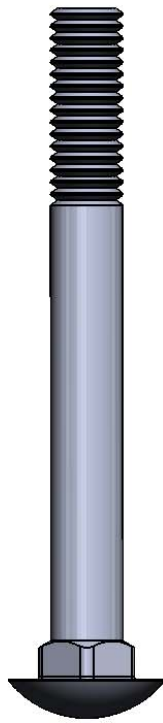

3/8 x 3-1/2"
 CARRIAGE BOLT
 QTY: 2

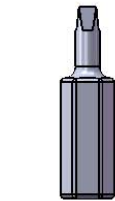
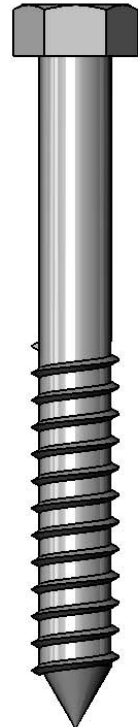
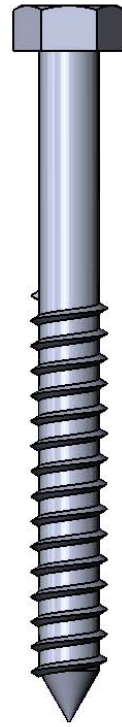

#2 SQUARE
 DRIVE BIT
 QTY: 1



PLASTIC
 BOLT CAP
 QTY: 19



USE THE RULER TO THE RIGHT TO MEASURE YOUR BOLTS AND SCREWS. PICTURE VIEWS SHOWN ABOVE ARE 1:1 SCALE AND CAN BE USED TO MATCH BOLT AND SCREW SIZES.

11-0029
 1200 HARDWARE
 12/4/2012
 REV B. J.H.
 PAGE 2 OF 2



#14 X 1-1/4"
 PAN HEAD SCREW
 QTY: 4

#8 X 1-1/2"
 WOOD SCREW
 QTY: 29



#8 X 1-3/4"
 WOOD SCREW
 QTY: 4



#8 X 2"
 WOOD SCREW
 QTY: 282



#8 X 2-1/2"
 WOOD SCREW
 QTY: 64



#8 X 3"
 WOOD SCREW
 QTY: 20

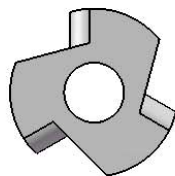

5/16" TEE NUT
 QTY: 38

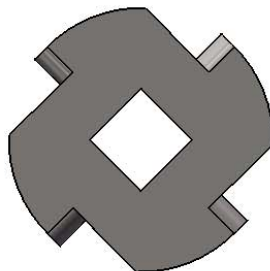

TORQUE WASHER
 QTY: 17

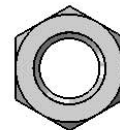

3/8" LOCK NUT
 QTY: 19

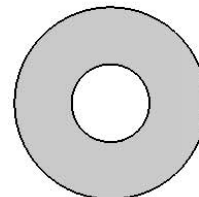

3/8" WASHER
 QTY: 31

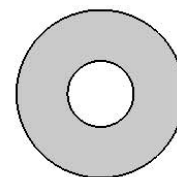

5/16" WASHER
 QTY: 68

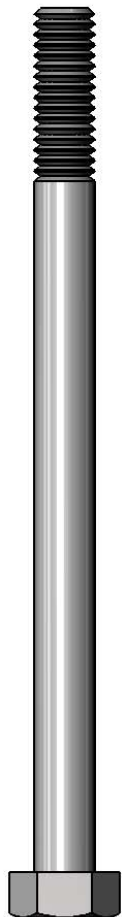

5/16 X 4-1/2"
 HEX BOLT
 QTY: 30



5/16 X 1-1/2"
 HEX BOLT
 QTY: 8

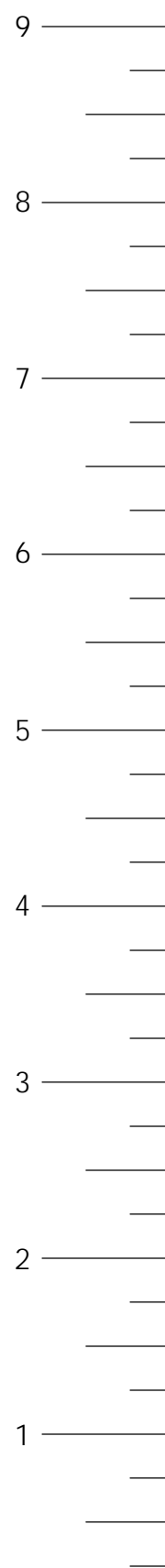

USE THE RULER TO THE RIGHT TO MEASURE YOUR BOLTS AND SCREWS. PICTURE VIEWS SHOWN ABOVE ARE 1:1 SCALE AND CAN BE USED TO MATCH BOLT AND SCREW SIZES.

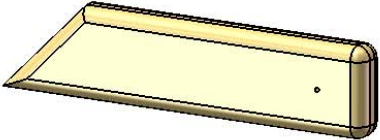
PICTURE	DESCRIPTION	QTY.
	<p>1 x 2 x 62-1/2" ROCK WALL BATTEN</p> <p>1-2-6250-RB</p>	<p>1</p>
	<p>5 x 5 x 53-1/2" ROOF PEAK</p> <p>5-5-5350-RP</p>	<p>1</p>
	<p>1 x 5 x 53-1/2" ROOF BOARD</p> <p>1-5-5350-RB</p>	<p>28</p>
	<p>1 x 5 x 53-1/2" ROOF STARTER</p> <p>1-5-5350-RS</p>	<p>2</p>
	<p>5/4 x 3 x 11" SMALL RAY</p> <p>125-3-1100-SR</p>	<p>4</p>
	<p>5/4 x 23 x 17" LARGE RAY</p> <p>125-3-1700-LR</p>	<p>2</p>
	<p>5/4 x 3 x 18-3/4" LADDER BACK</p> <p>125-3-1875-LB</p>	<p>1</p>

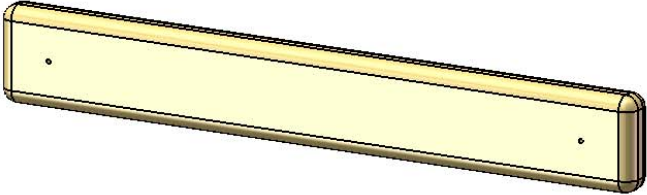
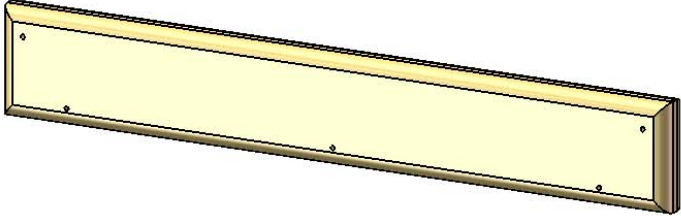
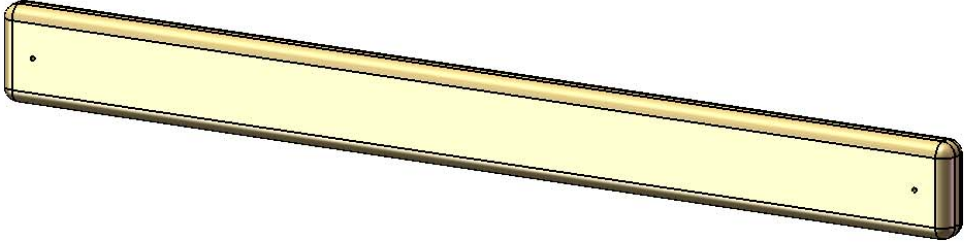
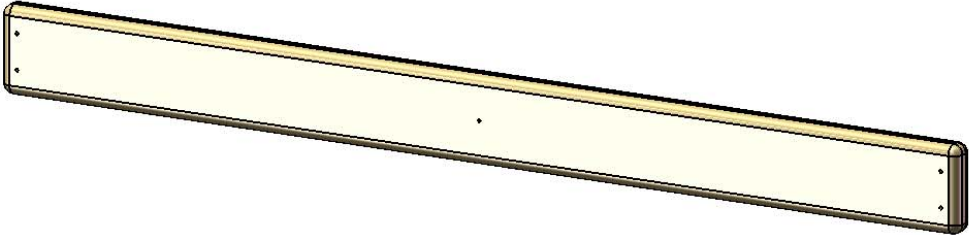
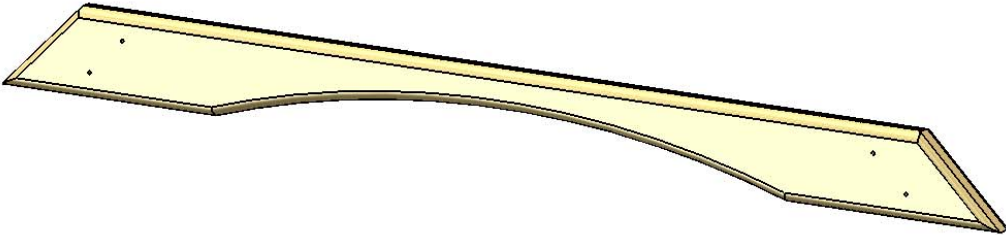
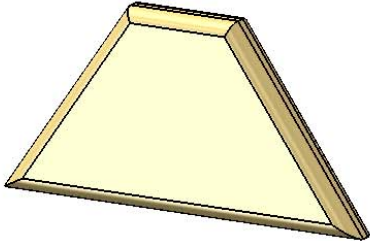
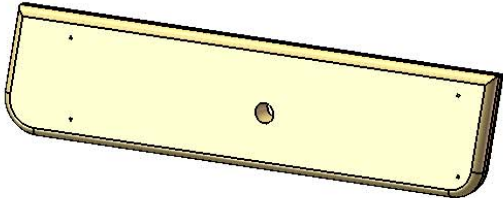
PICTURE	DESCRIPTION	QTY.
	<p>5/4 X 3 X 19" TIC TAC TOE MOUNT</p> <p>125-3-1900-TTMM</p>	<p>2</p>
	<p>5/4 X 3 X 21" ROCK WALL CAP</p> <p>125-3-2100-RWC</p>	<p>1</p>
	<p>5/4 X 3 X 28-1/2" PANEL SLAT</p> <p>125-3-2850-PS</p>	<p>24</p>
	<p>5/4 X 4 X 40-1/4" DECK SPACER</p> <p>125-4-4025-DS</p>	<p>2</p>
	<p>5/4 X 4 X 42" RAY SUPPORT</p> <p>125-4-4200-RS</p>	<p>2</p>
	<p>5/4 X 6 X 10-3/4" ROOF PEAK SUPPORT</p> <p>125-6-1075-RPS</p>	<p>2</p>
	<p>5/4 X 6 X 23- 11/16" BOTTOM ROCK WALL BOARD</p> <p>125-6-2368-BRWB</p>	<p>1</p>

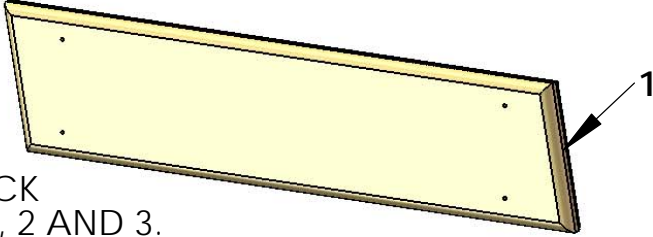
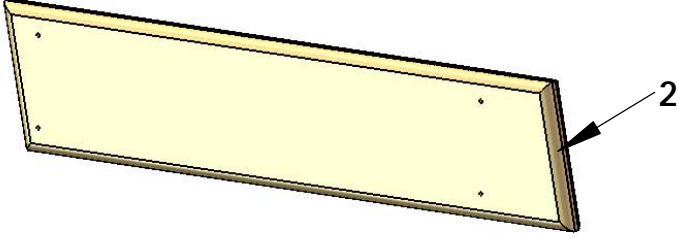
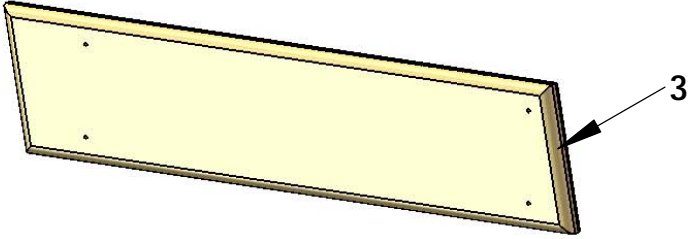
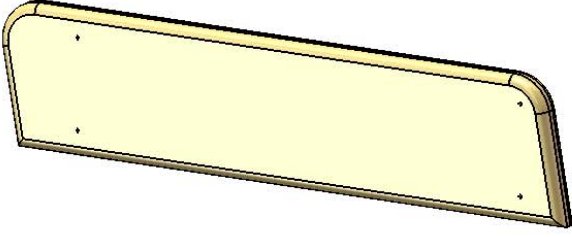
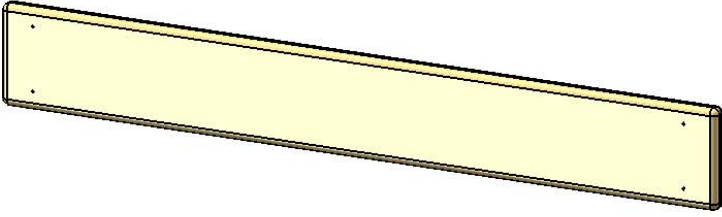
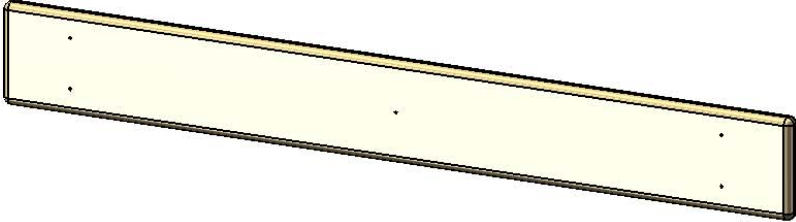
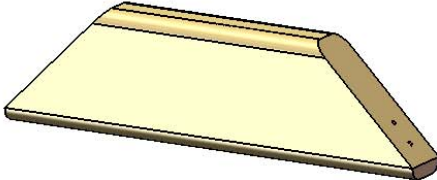

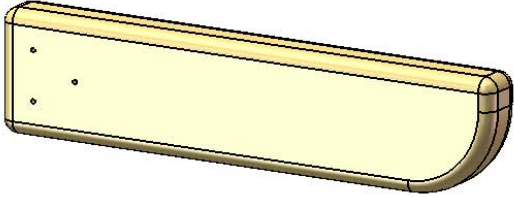
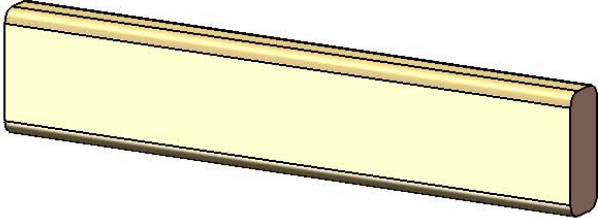
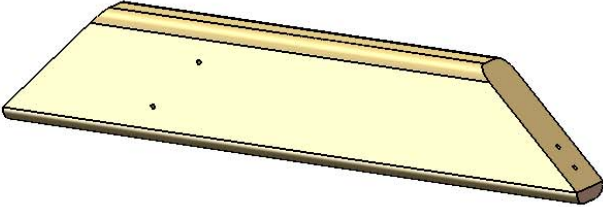
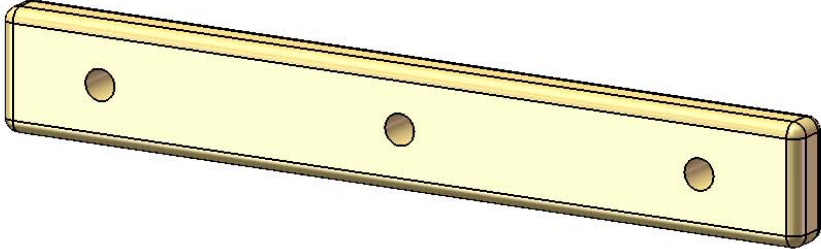
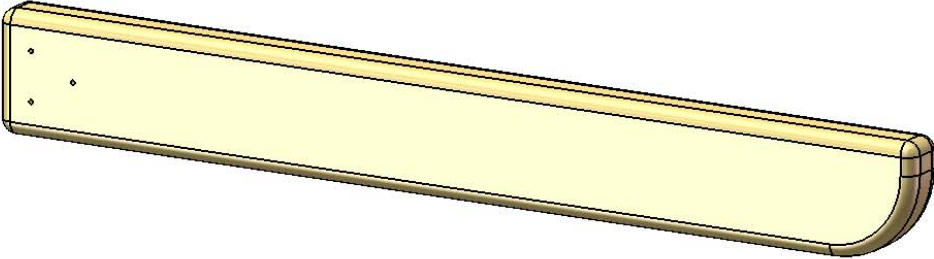
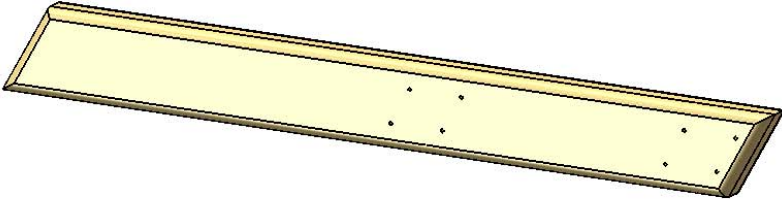
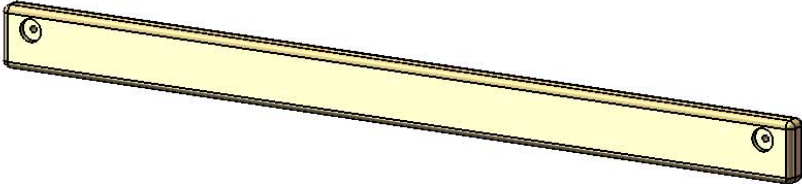

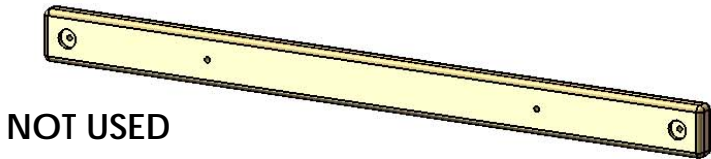
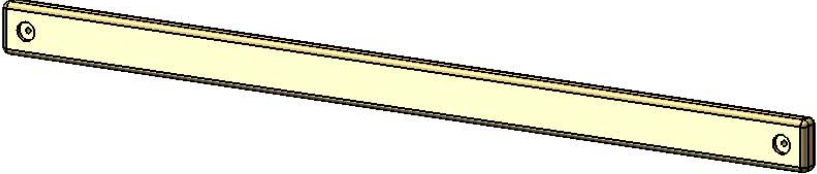
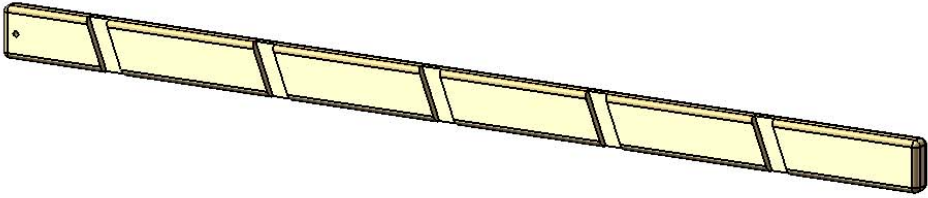
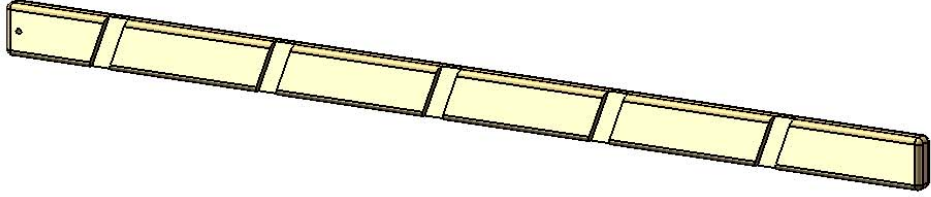
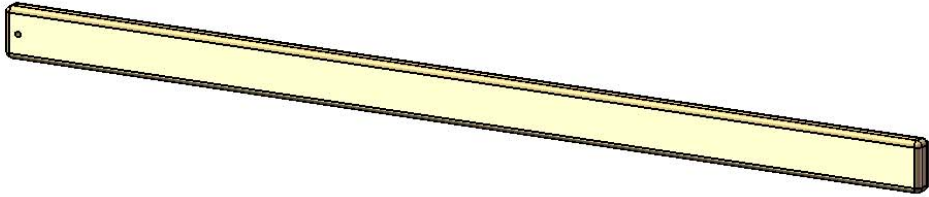
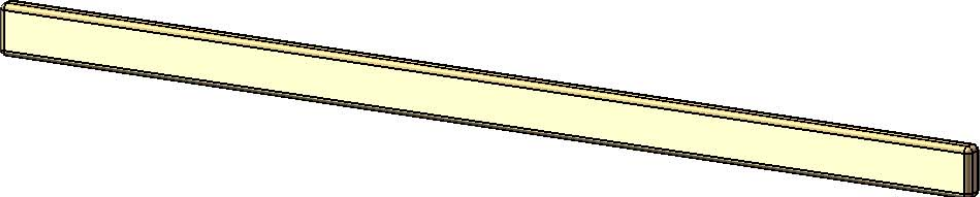
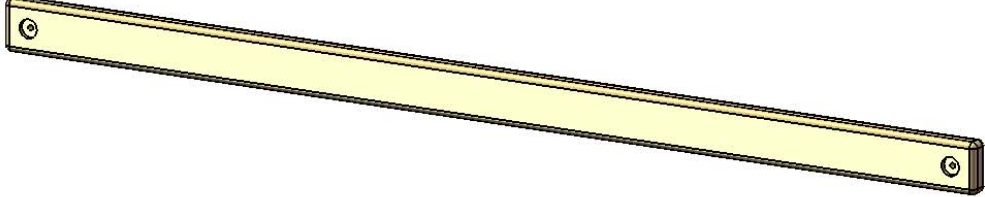
PICTURE	DESCRIPTION	QTY.
<p>SEE STEP 14 IN MANUAL FOR MORE DETAILS ABOUT IDENTIFYING ROCK WALL BOARDS 1, 2 AND 3.</p> 	<p>5/4 X 6 X 23- 15/16" ROCK WALL BOARD 1 125-6-2397-RWB1</p>	<p>4</p>
	<p>5/4 X 6 X 23- 15/16" ROCK WALL BOARD 2 125-6-2397-RWB2</p>	<p>4</p>
	<p>5/4 X 6 X 23- 15/16" ROCK WALL BOARD 3 125-6-2397-RWB3</p>	<p>2</p>
	<p>5/4 X 6 X 23- 11/16" TOP ROCKWALL BOARD 125-6-2368-TRWB</p>	<p>1</p>
	<p>5/4 X 6 X 43" PICNIC TABLE TOP & SEAT BOARD 125-6-4300-PTTS</p>	<p>4</p>
	<p>5/4 X 6 X 47-3/8" DECK BOARD 125-6-4738-DB</p>	<p>11</p>
	<p>2 X 4 X 13" ANGLE SUPPORT 2-4-1300-AS</p>	<p>4</p>

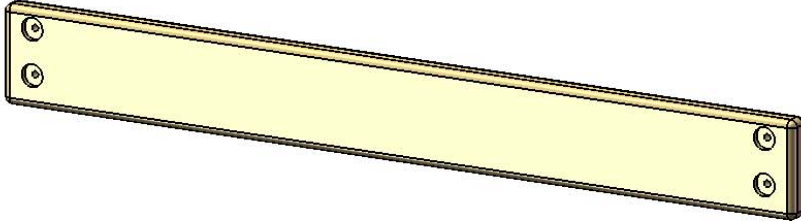
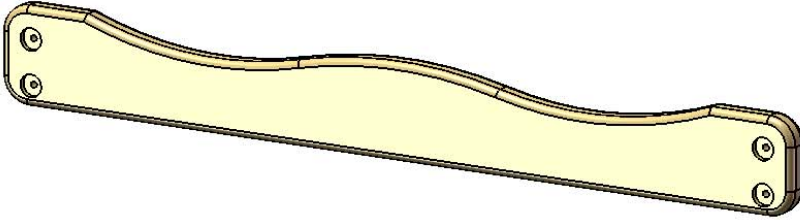
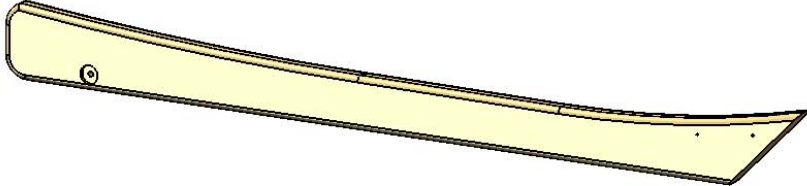
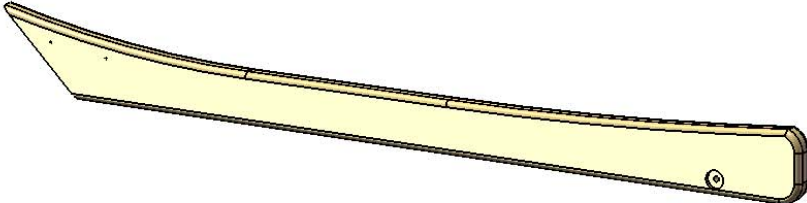
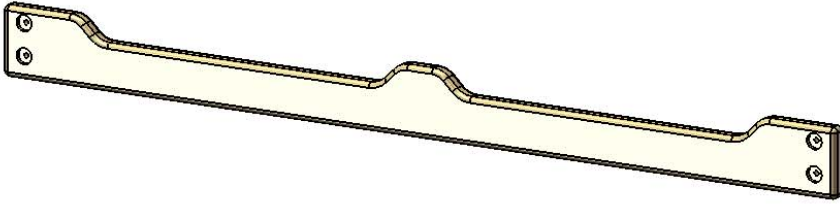
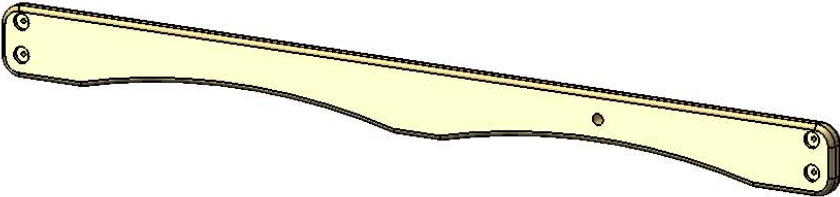
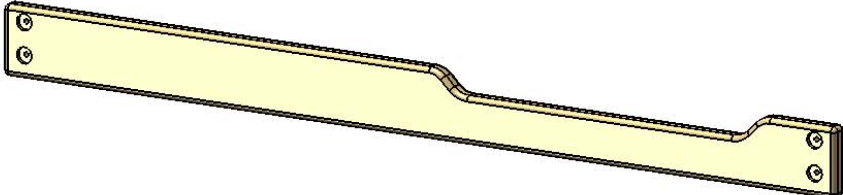
PICTURE	DESCRIPTION	QTY.
	<p>2 x 4 x 14-3/4" PICNIC TABLE TOP SUPPORT</p> <p>2-4-1475-PTTS</p>	<p>2</p>
	<p>2 x 4 x 17" LADDER STEP</p> <p>2-4-1700-LS</p>	<p>5</p>
	<p>2 x 4 x 18" ANGLE SUPPORT</p> <p>2-4-1800-AS</p>	<p>4</p>
	<p>2 x 4 x 24" ROPE LADDER RUNG</p> <p>2-4-2400-RLR</p>	<p>6</p>
	<p>2 x 4 x 27-1/2" PICNIC TABLE SEAT SUPPORT</p> <p>2-4-1475-PTTS</p>	<p>2</p>
	<p>2 x 4 x 32-1/2" PICNIC TABLE LEG</p> <p>2-4-3250-PTL</p>	<p>2</p>
	<p>2 x 4 x 47-1/2" SAFETY/BOTTOM PANEL BOARD</p> <p>2-4-4750-SBPB</p>	<p>3</p>

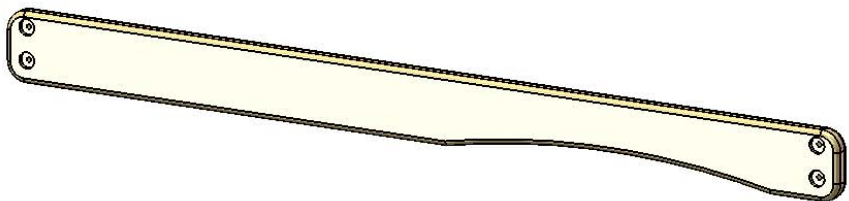
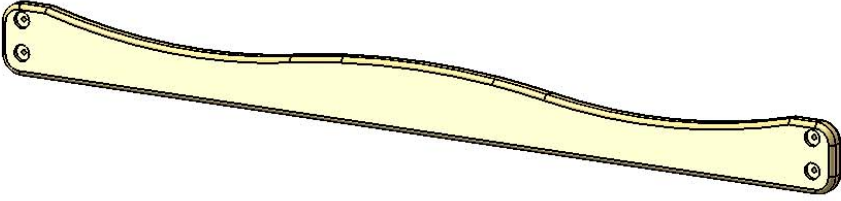
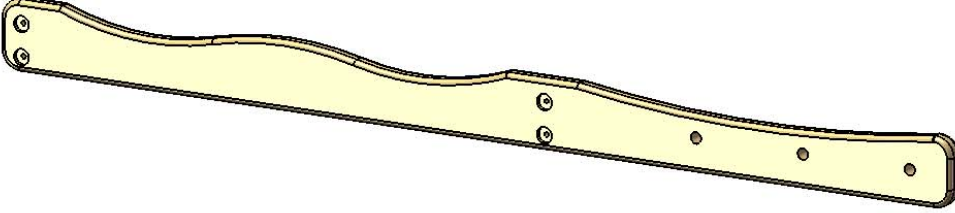
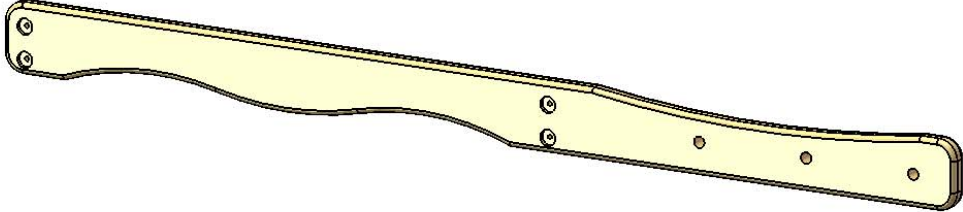
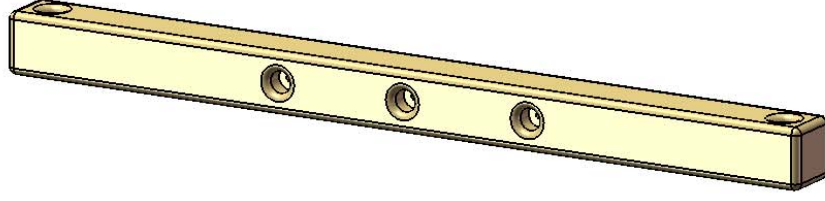
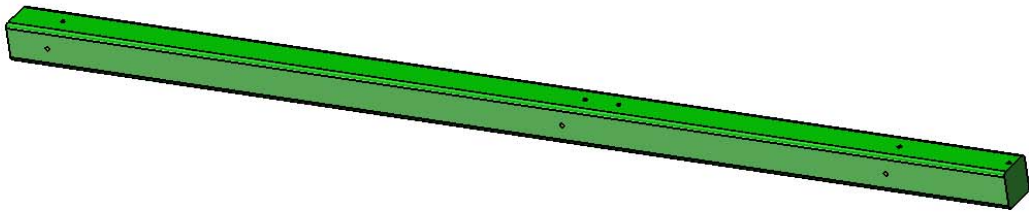
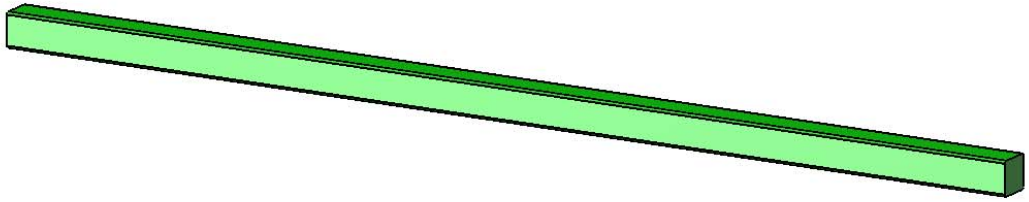

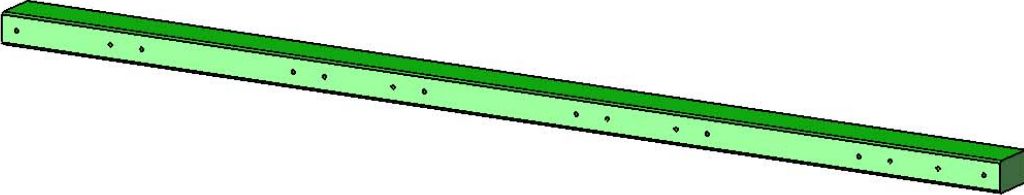
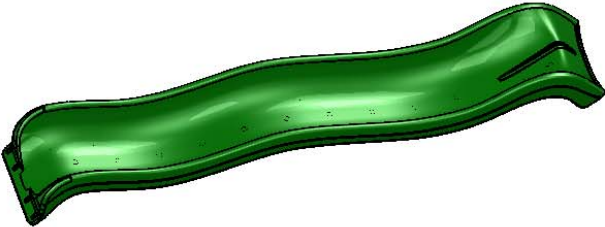

PICTURE	DESCRIPTION	QTY.
 <p>NOT USED</p>	<p>2 X 4 X 47-1/2" TOY CHEST ATTACHMENT BOARD</p> <p>2-4-4750-TCAB</p>	<p>1</p>
	<p>2 X 4 X 58" SWING LEG CROSS MEMBER</p> <p>2-4-5800-CM</p>	<p>1</p>
	<p>2 X 4 X 66" LADDER LEFT SIDE</p> <p>2-4-6600-LLS</p>	<p>1</p>
	<p>2 X 4 X 66" LADDER RIGHT SIDE</p> <p>2-4-6600-LRS</p>	<p>1</p>
	<p>2 X 4 X 66" ROCK WALL SIDE</p> <p>2-4-6600-RWS</p>	<p>2</p>
	<p>2 X 4 X 70" CENTER DECK SUPPORT</p> <p>2-4-7000-CDS</p>	<p>1</p>
	<p>2 X 4 X 70" DECK SUPPORT</p> <p>2-4-7000-DS</p>	<p>2</p>

PICTURE	DESCRIPTION	QTY.
	<p>2 X 6 X 47-1/2" BOTTOM PANEL BOARD</p> <p>2-6-4750-BPB</p>	<p>2</p>
	<p>2 X 6 X 47-1/2" LEFT SANDBOX BOARD</p> <p>2-6-4750-LSB</p>	<p>1</p>
	<p>2 X 6 X 57-1/2" ROOF SUPPORT LEFT</p> <p>2-6-5750-RSL</p>	<p>2</p>
	<p>2 X 6 X 57-1/2" ROOF SUPPORT RIGHT</p> <p>2-6-5750-RSR</p>	<p>2</p>
	<p>2 X 6 X 70" FRONT DECK PANEL BOARD</p> <p>2-6-7000-FDPB</p>	<p>1</p>
	<p>2 X 6 X 70" FRONT TOP PANEL BOARD</p> <p>2-6-7000-FTPB</p>	<p>1</p>
	<p>2 X 6 X 70" REAR DECK PANEL BOARD</p> <p>2-6-7000-RDPB</p>	<p>1</p>

PICTURE	DESCRIPTION	QTY.
	<p>2 X 6 X 70" REAR TOP PANEL BOARD 2-6-7000-RTPB</p>	<p>1</p>
	<p>2 X 6 X 70" SANDBOX BOARD 2-6-7000-SB</p>	<p>2</p>
	<p>2 X 6 X 80" ROPE LADDER RUNNER 2-6-8000-RLR</p>	<p>1</p>
	<p>2 X 6 X 80" ROPE LADDER SUPPORT 2-6-8000-RLS</p>	<p>1</p>
	<p>4 X 4 X 47-1/2" SWING BEAM SUPPORT 4-4-4750-SBM</p>	<p>1</p>
	<p>4 X 4 X 96" CORNER POST 4-4-9600-CP</p>	<p>4</p>
	<p>4 X 4 X 108" SWING LEG 4-4-10800-SL</p>	<p>2</p>

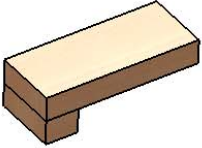
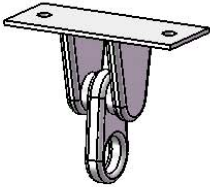
PICTURE	DESCRIPTION	QTY.
	<p>4 X 6 X 120" SWING BEAM 4-6-12000-SB</p>	<p>1</p>
<p>(NOT SHOWN)</p>	<p>3/4" DIAMETER X 10 FEET (GREEN) ROCK WALL ROPE</p>	<p>1</p>
<p>(NOT SHOWN)</p>	<p>3/4" DIAMETER X 13 FEET (GREEN) ROPE LADDER ROPE</p>	<p>3</p>
	<p>WAVE SLIDE 03-0013</p>	<p>1</p>
	<p>SWING BELT W/CHAINS 04-0002</p>	<p>2</p>
	<p>TRAPEZE BAR W/CHAINS 04-0006</p>	<p>1</p>
	<p>TIC TAC TOE PANEL 07-0010</p>	<p>1</p>

PICTURE	DESCRIPTION	QTY.
	TELESCOPE 07-0001	1
	FLAG KIT (PAIR) 09-1014	1
	SAFETY HANDLES PLASTIC (PAIR) 07-0005	1
	SWING BEAM PLATE 11-5002	1
	SWING LEG BRACKET 11-5010	1
	ROCK WALL ROCKS (PACKAGE OF 5) 07-0008	2
<p data-bbox="77 1843 998 1873">NOTE: GROUND STAKES MAY BE PLASTIC OR WOOD AT OUR DISCRETION.</p> 	GROUND STAKES (PLASTIC) 07-0016	2

PICTURE	DESCRIPTION	QTY.
(NOT SHOWN)	NAME PLATE	1
(NOT SHOWN)	HARDWARE BOX 11-0029	1
	SPACER BLOCK	2
	IRON DUCTILE SWING HANGER 11-4012	6
	SPRING CLIP 11-4003	6
	90° BRACKET 11-5013	4
	STEERING WHEEL 07-0004	1

STEP 1: ATTACHING T-NUTS TO THE CORNER POSTS

1: THIS STEP IS CRITICAL TO BUILDING THE FORT PROPERLY. IF ANY MISTAKES ARE MADE HERE, YOU WILL NEED TO DIS-ASSEMBLE AND THEN RE-ASSEMBLE TO MAKE YOUR CORRECTIONS.

2: MAKE SURE HOLES ARE FREE OF ANY OBSTRUCTIONS. USE A BOLT TO CLEAN OUT ANY DEBRIS.

3: LAY OUT EACH OF THE 4 X 4 X 96" CORNER POSTS IN THE AREA YOU INTEND ON BUILDING THE FORT SIDE OF THE PLAYSET.

4: USE THE DIAGRAM BELOW TO CORRECTLY IDENTIFY AND ORIENT THE NECESSARY DIRECTION THE POSTS SHOULD FACE.

5: USE A HAMMER TO SEAT THE T-NUTS AFTER INSERTING THEM INTO THE HOLES SHOWN IN THE DIAGRAM BELOW.

6: THE BARREL OF THE T-NUT SHOULD GO IN THE HOLE FIRST. HAMMER THE T-NUT UNTIL IT IS FLUSH/ALMOST FLUSH TO THE CORNER POSTS.

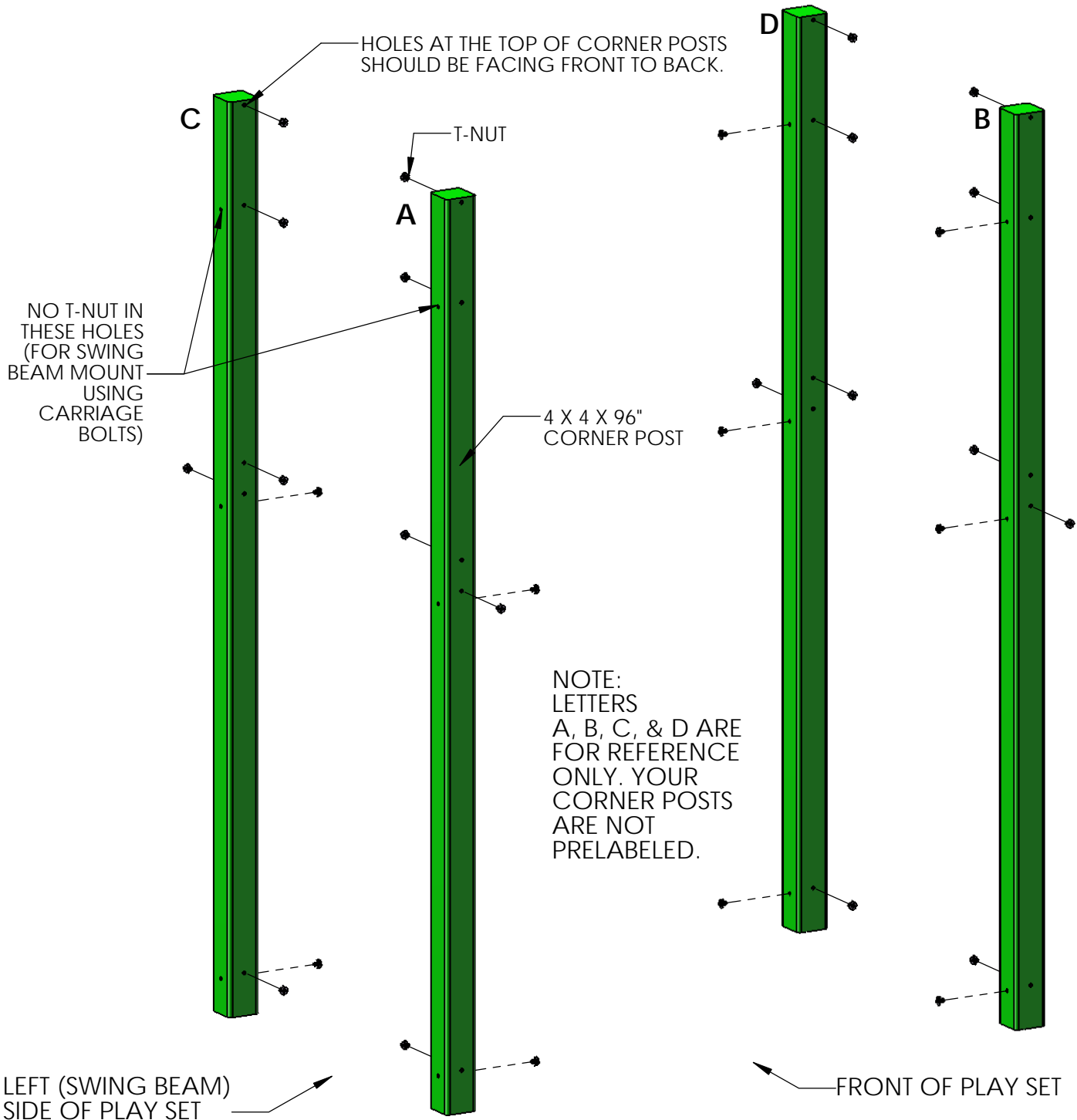

STEP 2: ASSEMBLING THE RIGHT SIDE FRAME

- 1: LAY THE RIGHT SIDE CORNER POSTS ON THE GROUND IN THEIR PROPER ORIENTATION. TOPMOST HOLES FACE FRONT TO BACK. T-NUTS FACE EACH OTHER BETWEEN POSTS.
- 2: LAY THE 2 X 6 X 80" ROPE LADDER RUNNER ON TOP OF THE RIGHT SIDE CORNER POSTS AT THE BOTTOM OF THE CORNER POSTS. THE HOLES IN THE ROPE LADDER RUNNER ARE OFFSET DOWN.
- 3: USE 5/16" X 4-1/2" HEX BOLTS AND 5/16" WASHERS TO ATTACH THE TOP HOLES OF THE SANDBOX BOARD TO THE T-NUTS INSTALLED ON THE CORNER POSTS. THE BOTTOM HOLES WILL BE USED LATER.
- 4: LAY THE 2 X 6 X 47-1/2" BOTTOM PANEL BOARD ON TOP OF THE RIGHT SIDE CORNER POSTS IN THE MIDDLE OF THE CORNER POSTS. THE HOLES IN THE BOTTOM PANEL BOARD ARE OFFSET DOWN.
- 5: USE 5/16" X 4-1/2" HEX BOLTS AND 5/16" WASHERS TO ATTACH THE BOTTOM HOLES OF THE BOTTOM PANEL BOARD TO THE T-NUTS INSTALLED ON THE CORNER POSTS. THE TOP HOLES WILL BE USED LATER.
- 6: LAY THE 2 X 6 X 80" ROPE LADDER SUPPORT ON TOP OF THE RIGHT SIDE CORNER POSTS. THE HOLES IN THE ROPE LADDER SUPPORT ARE OFFSET DOWN.
- 7: USE 5/16" X 4-1/2" HEX BOLTS AND 5/16" WASHERS TO ATTACH THE TOP HOLES OF THE ROPE LADDER SUPPORT TO THE T-NUTS INSTALLED ON THE CORNER POSTS.
- 8: DO NOT INSTALL ANY LAG SCREWS AT THIS TIME.

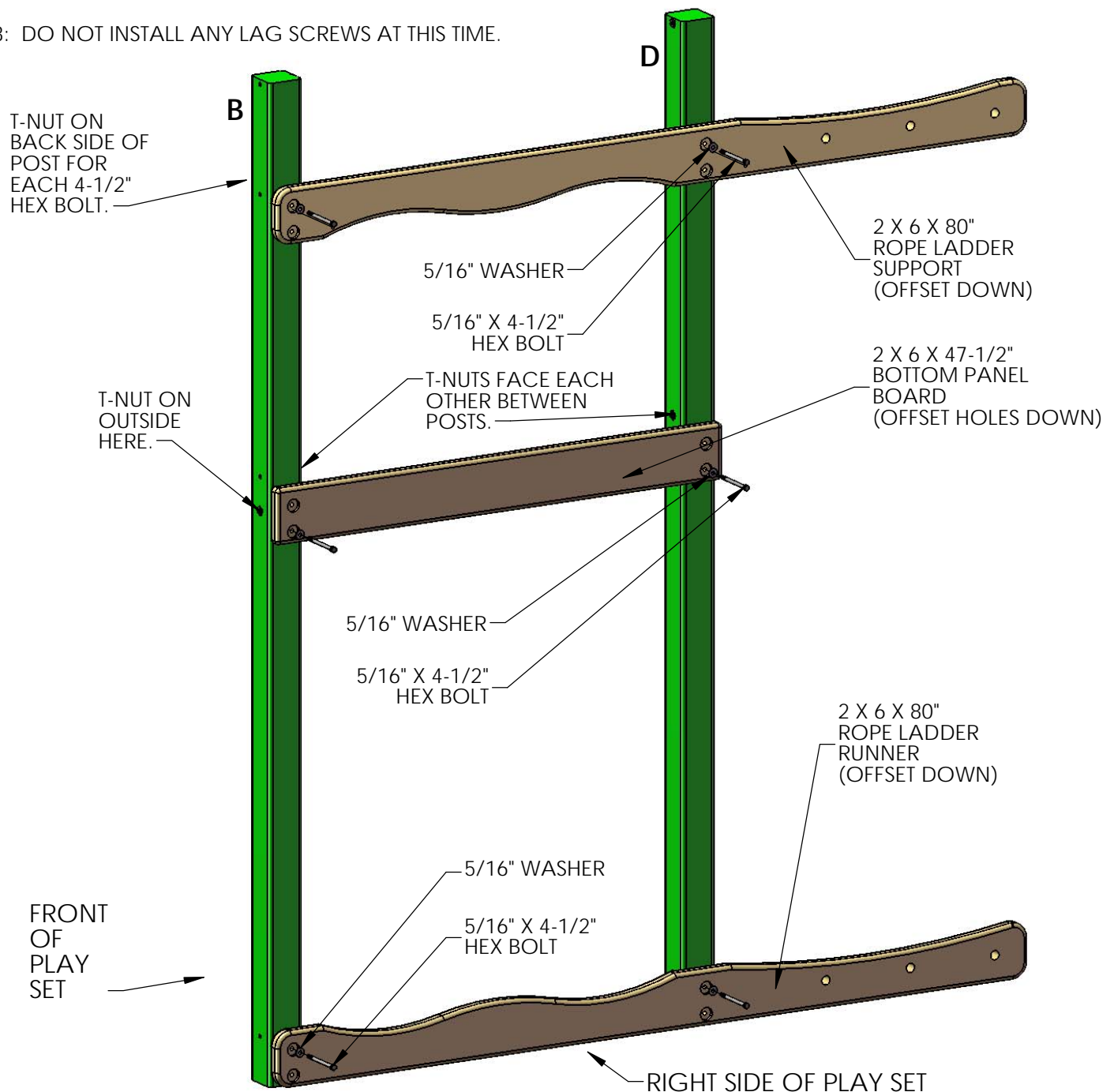

STEP 3: ASSEMBLING THE LEFT SIDE FRAME

- 1: LAY THE LEFT SIDE CORNER POSTS ON THE GROUND IN THEIR PROPER ORIENTATION.
- 2: LAY THE 2 X 6 X 47-1/2" LEFT SANDBOX BOARD ON TOP OF THE LEFT SIDE CORNER POSTS AT THE BOTTOM OF THE CORNER POSTS. THE HOLES IN THE LEFT SANDBOX BOARD ARE OFFSET DOWN..
- 3: USE 5/16 X 4-1/2" HEX BOLTS AND 5/16" WASHERS TO ATTACH THE TOP HOLES OF THE SANDBOX BOARD TO THE T-NUTS INSTALLED ON THE CORNER POSTS. THE BOTTOM HOLES WILL BE USED LATER.
- 4: LAY THE 2 X 6 X 47-1/2" BOTTOM PANEL BOARD ON TOP OF THE LEFT SIDE CORNER POSTS IN THE MIDDLE OF THE CORNER POSTS. THE HOLES IN THE BOTTOM PANEL BOARD ARE OFFSET DOWN.
- 5: USE 5/16 X 4-1/2" HEX BOLTS AND 5/16" WASHERS TO ATTACH THE BOTTOM HOLES OF THE BOTTOM PANEL BOARD TO THE T-NUTS INSTALLED ON THE CORNER POSTS. THE TOP HOLES WILL BE USED LATER.
- 6: LAY THE 4 X 4 X 47-1/2" SWING BEAM SUPPORT ON TOP OF THE LEFT SIDE CORNER POSTS. THE THREE COUNTERSUNK HOLES IN THE MIDDLE OF THE SWING BEAM SUPPORT MUST FACE DOWNWARD.
- 7: FIND TWO TORQUE WASHERS. PLACE A 3/8" X 6-1/2" CARRIAGE BOLT INSIDE THE TORQUE WASHER, MAKING SURE THAT THE TEETH ARE FACING IN THE SAME DIRECTION AS THE THREADS OF THE CARRIAGE BOLT. PLACE THE TORQUE WASHER/CARRIAGE BOLT ASSEMBLY INTO THE HOLES OF THE CORNER POST SO THAT THE HEAD OF THE CARRIAGE BOLT FACES WHAT WILL BE THE INSIDE OF THE FORT. USE A HAMMER TO SET THE TORQUE WASHER INTO THE CORNER POST.
- 8: ATTACH THE SWING BEAM SUPPORT TO THE CORNER POSTS WITH 3/8" WASHERS AND 3/8" LOCK NUTS AS SHOWN IN DETAIL Z. COVER ANY EXPOSED THREADS WITH BOLT CAPS.

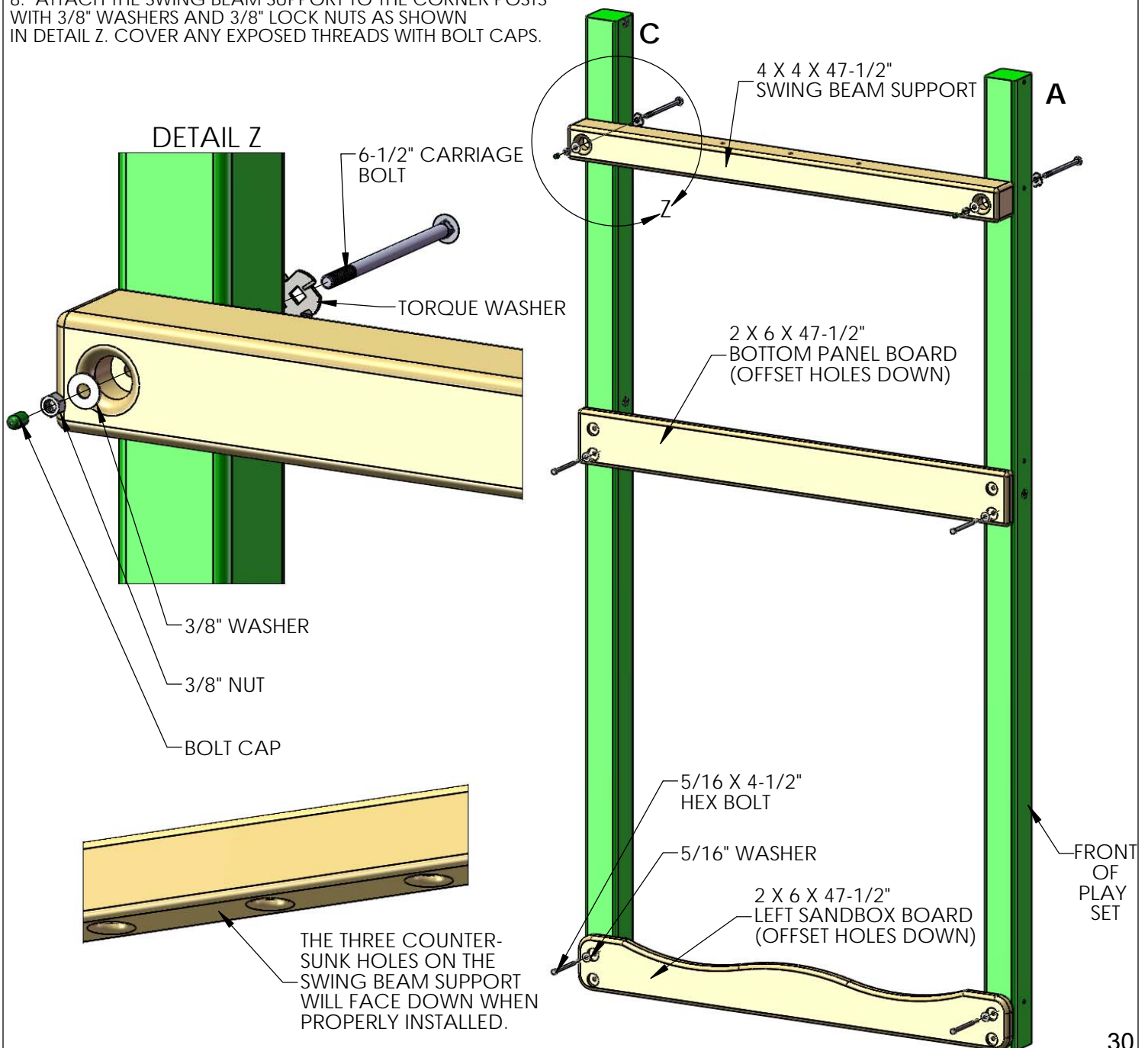

STEP 4: DECK SUPPORTS

YOU WILL NEED AN EXTRA PERSON FOR THIS STEP.

1: WITH HELP, STAND UP THE LEFT AND RIGHT SIDE ASSEMBLIES.

2: FASTEN THE 2 X 4 X 70" DECK SUPPORTS TO THE HOLES AT 54-3/4" WITH 5/16 X 4-1/2" HEX BOLTS AND 5/16" WASHERS FROM THE INSIDE OF THE FRONT

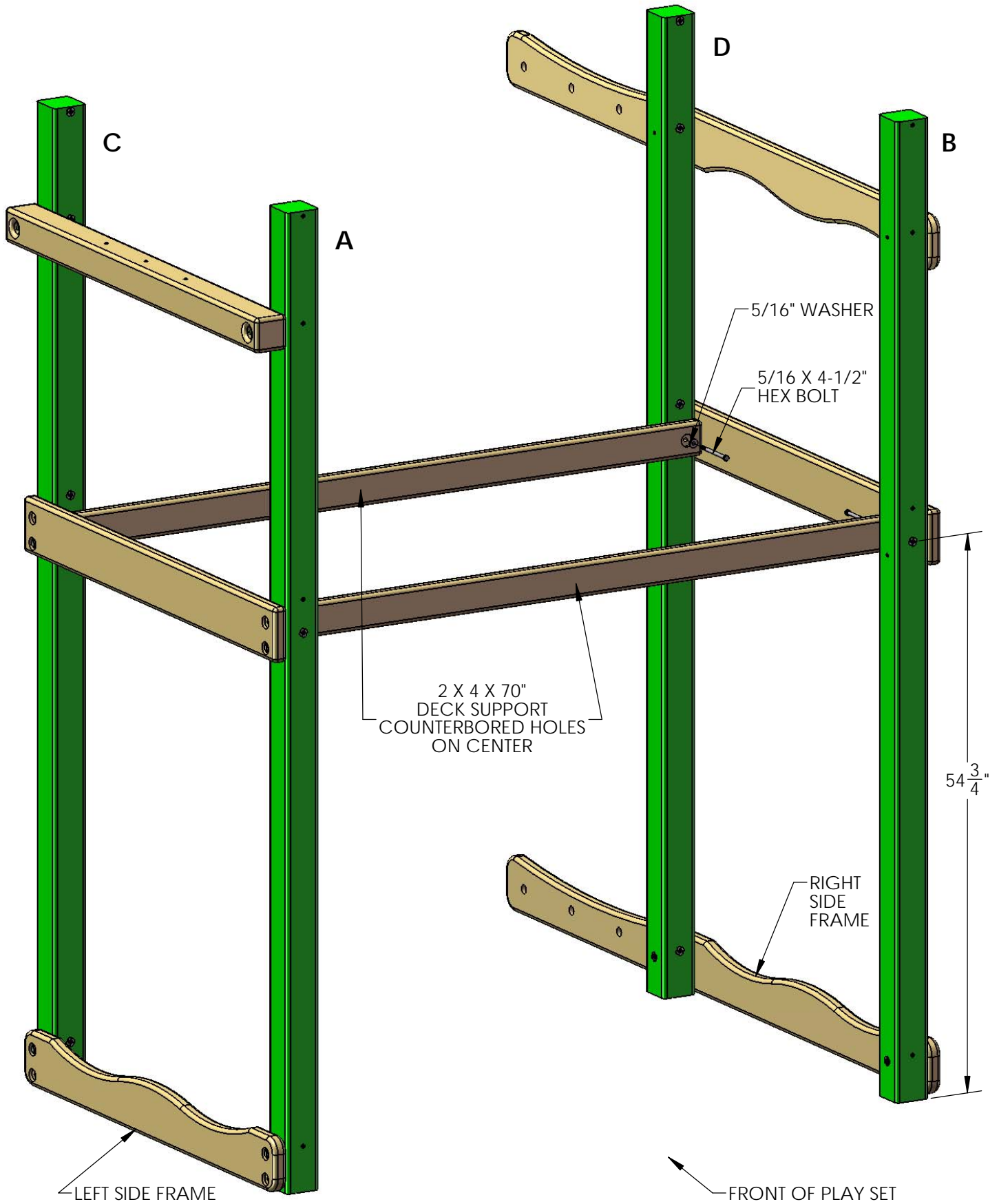

STEP 5: FRONT FRAME ASSEMBLY

- 1: PLACE THE 2 X 6 X 70" SANDBOX BOARD ON THE FRONT OF THE CORNER POSTS. THE HOLES IN THE SANDBOX BOARD ARE OFFSET UP.
- 2: USE 5/16 X 4-1/2" HEX BOLTS AND 5/16" WASHERS TO ATTACH THE TOP HOLES OF THE SANDBOX BOARD TO THE T-NUTS INSTALLED ON THE CORNER POSTS. THE BOTTOM HOLES WILL BE USED LATER.
- 3: PLACE THE 2 X 6 X 70" FRONT DECK PANEL BOARD WITH NOTCHES ON THE FRONT OF THE CORNER POSTS. THE HOLES IN THE FRONT DECK PANEL BOARD ARE OFFSET UP.
- 4: USE 5/16 X 4-1/2" HEX BOLTS AND 5/16" WASHERS TO ATTACH THE TOP HOLES OF THE FRONT DECK PANEL BOARD TO THE T-NUTS INSTALLED ON THE CORNER POSTS. THE BOTTOM HOLES WILL BE USED LATER.
- 5: PLACE THE 2 X 4 X 70" FRONT TOP PANEL BOARD ON THE FRONT OF THE CORNER POSTS. THE HOLES IN THE FRONT TOP PANEL BOARD ARE OFFSET UP.
- 6: USE 5/16 X 4-1/2" HEX BOLTS AND 5/16" WASHERS TO ATTACH THE TOP HOLES OF THE FRONT TOP PANEL BOARD TO THE T-NUTS INSTALLED ON THE CORNER POSTS.

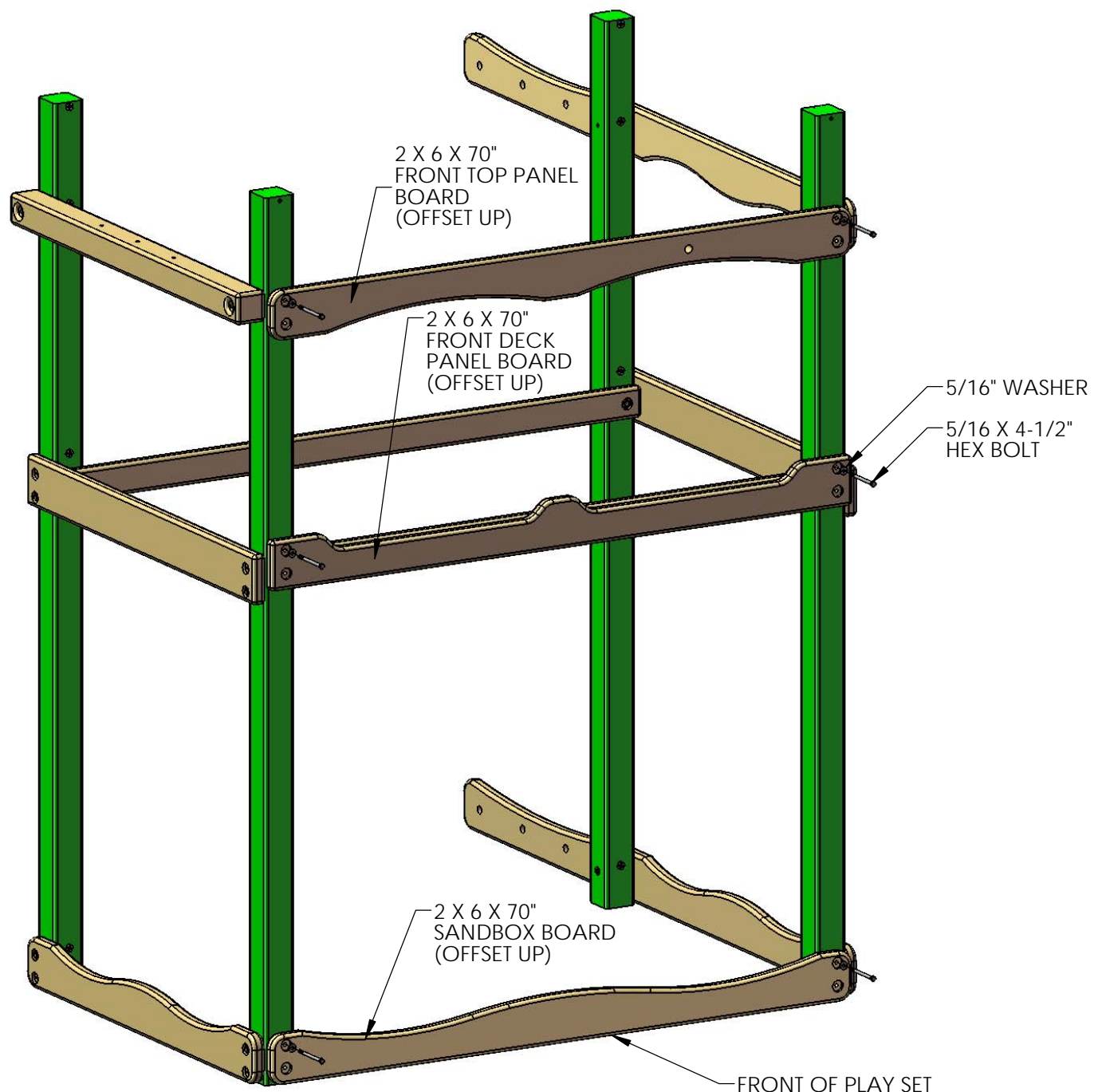

STEP 6: REAR FRAME ASSEMBLY

1: PLACE THE 2 X 6 X 70" SANDBOX BOARD ON THE REAR OF THE CORNER POSTS. THE HOLES IN THE SANDBOX BOARD ARE OFFSET UP.

2: USE 5/16" X 4-1/2" HEX BOLTS AND 5/16" WASHERS TO ATTACH THE TOP HOLES OF THE SANDBOX BOARD TO THE T-NUTS INSTALLED ON THE CORNER POSTS. THE BOTTOM HOLES WILL BE USED LATER.

3: PLACE THE 2 X 6 X 70" REAR DECK PANEL BOARD ON THE FRONT OF THE CORNER POSTS. THE HOLES IN THE REAR DECK PANEL BOARD ARE OFFSET UP.

4: USE 5/16" X 4-1/2" HEX BOLTS AND 5/16" WASHERS TO ATTACH THE TOP HOLES OF THE REAR DECK PANEL BOARD TO THE T-NUTS INSTALLED ON THE CORNER POSTS. THE BOTTOM HOLES WILL BE USED LATER.

5: PLACE THE 2 X 4 X 70" REAR TOP PANEL BOARD ON THE FRONT OF THE CORNER POSTS. THE HOLES IN THE TOP PANEL BOARD ARE OFFSET UP.

6: USE 5/16" X 4-1/2" HEX BOLTS AND 5/16" WASHERS TO ATTACH THE TOP HOLES OF THE REAR TOP PANEL BOARD TO THE T-NUTS INSTALLED ON THE CORNER POSTS.

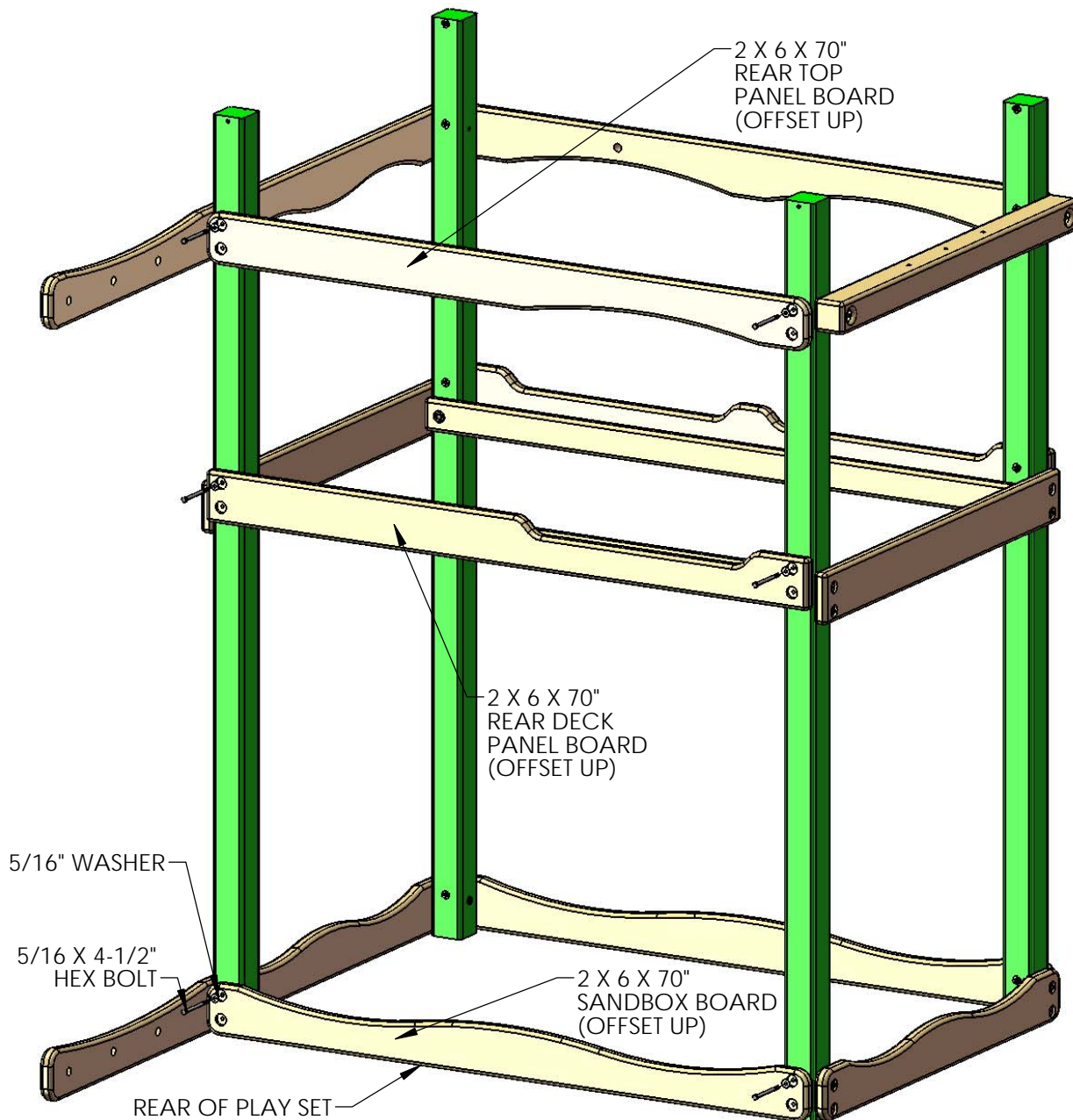

STEP 7: LAG SCREWS

1: AT THIS POINT THE FRAME IS UNSTABLE. YOU MUST HAVE AN ASSISTANT HELP YOU MOVE THE FRAME TO AVOID RACKING THE FRAME AND POTENTIALLY CRACKING BOARDS.

2: PLACE THE FRAME IN ITS FINAL POSITION AND FOLLOW THE PROCEDURES AT THE FRONT OF THE MANUAL TO LEVEL AND SQUARE THE STRUCTURE. ONCE THE FRAME IS LEVEL, SQUARE, AND SET INTO POSITION; GO BACK AND INSERT THE 5/16" X 3-1/2" LAG SCREWS AND 5/16" WASHERS IN ALL OF THE REMAINING HOLES OF THE 2 X 6 PARTS. NOTE: THERE WILL NOT BE ANY PREDRILLED HOLES IN THE CORNER POSTS FOR THE LAG SCREWS. LAG SCREWS ARE SELF-TAPPING.

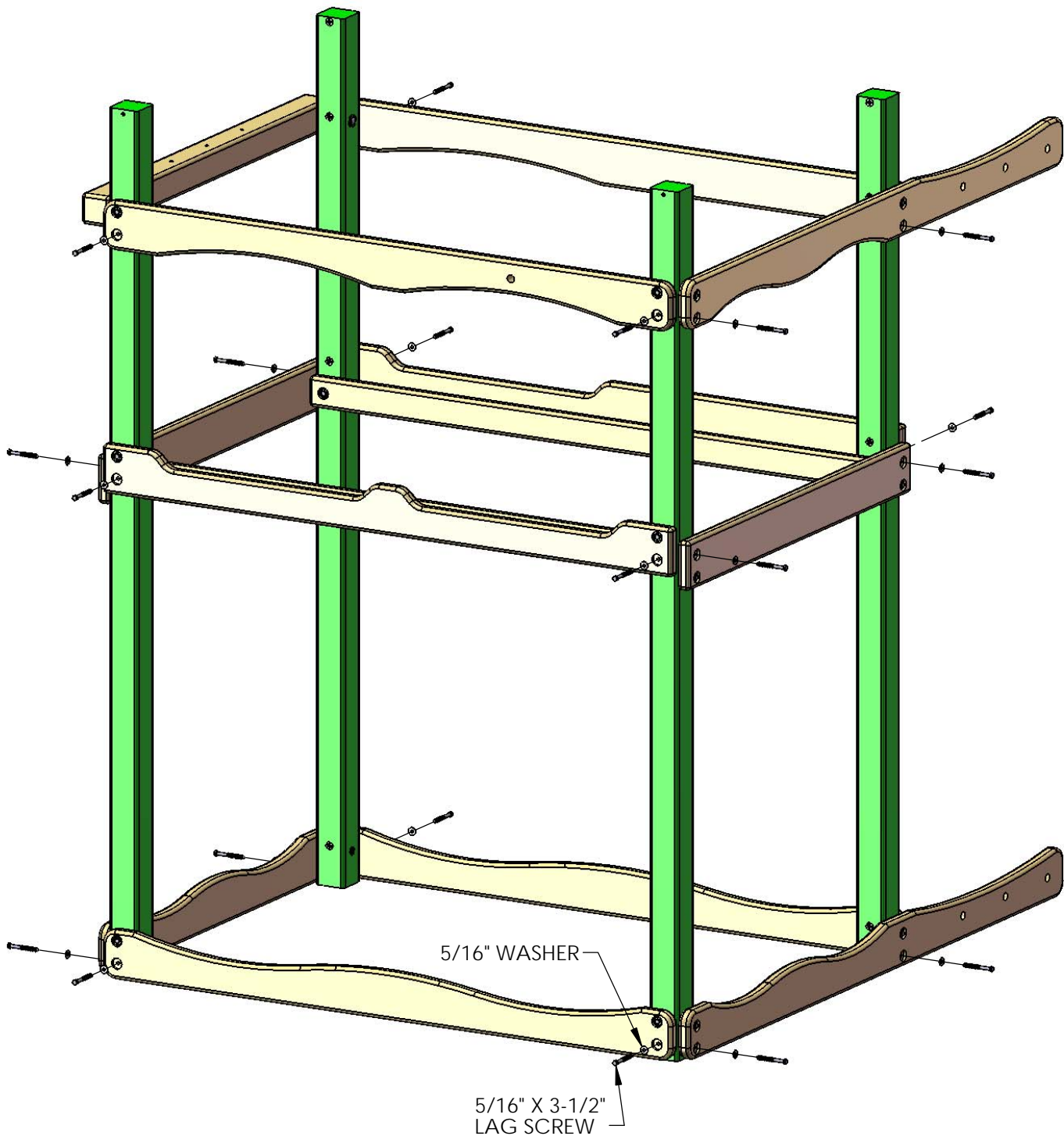

STEP 8: ANGLE SUPPORTS

1: THE FOUR 2 X 4 X 13" ANGLE SUPPORTS ARE MOUNTED UNDERNEATH THE AREA WHERE THE DECK WILL BE LOCATED ON THE FRONT AND BACK OF THE FORT.

2: USE TWO 2-1/2" WOOD SCREWS THROUGH THE DECK SUPPORT INTO THE TOP OF THE ANGLE SUPPORT, AND ONE 2" AND ONE 3" WOOD SCREW TO FASTEN THE ANGLE SUPPORT TO THE CORNER POSTS.

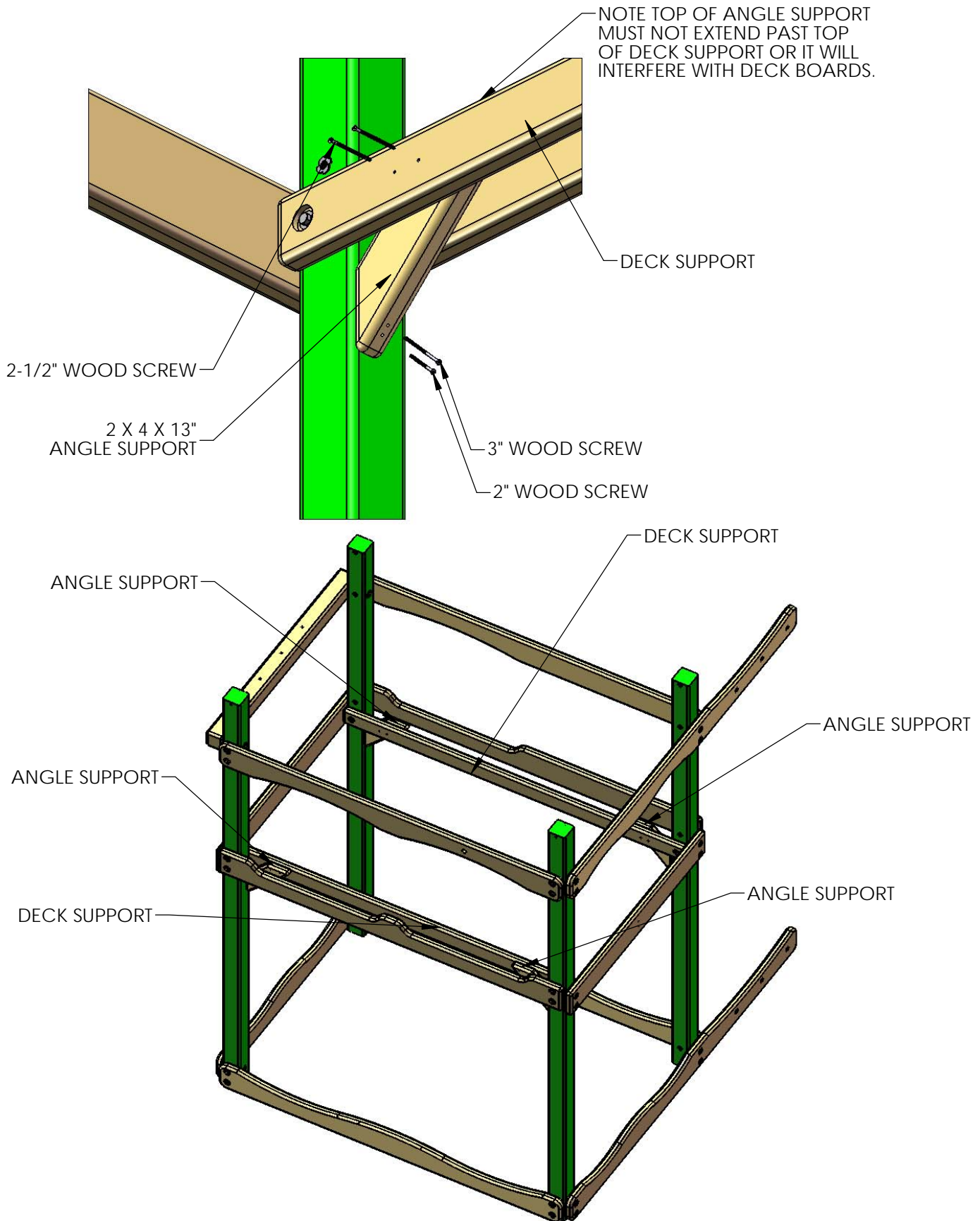

STEP 9: ANGLE SUPPORTS

1: THE FOUR 2 X 4 X 18" ANGLE SUPPORTS ARE MOUNTED UNDER THE DECK ON THE LEFT AND RIGHT SIDES OF THE FORT.

2: USE TWO 2-1/2" WOOD SCREWS ON TOP OF THE ANGLE SUPPORT, AND ONE 2" AND ONE 3" WOOD SCREW TO FASTEN THE ANGLE SUPPORT TO THE CORNER POSTS.

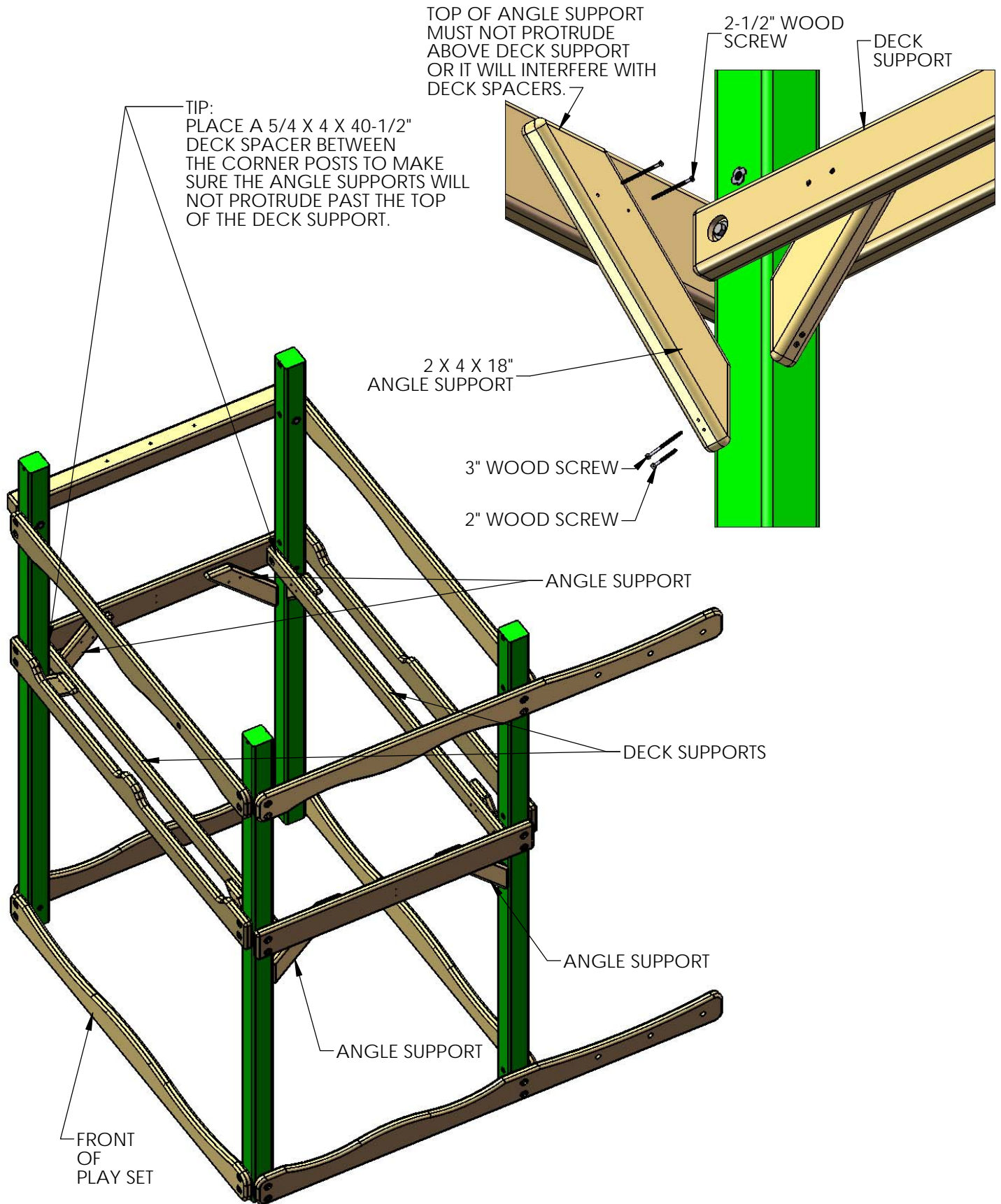

STEP 10: BOTTOM PANEL BOARDS

1: PLACE THE 2 X 4 X 47-1/2" BOTTOM PANEL BOARD ON TOP OF THE 2 X 6 PANEL BOARD WITH OFFSET HOLES UP AND FASTEN TO THE CORNER POSTS WITH 5/16 X 3-1/2" LAG SCREWS WITH 5/16" WASHERS.

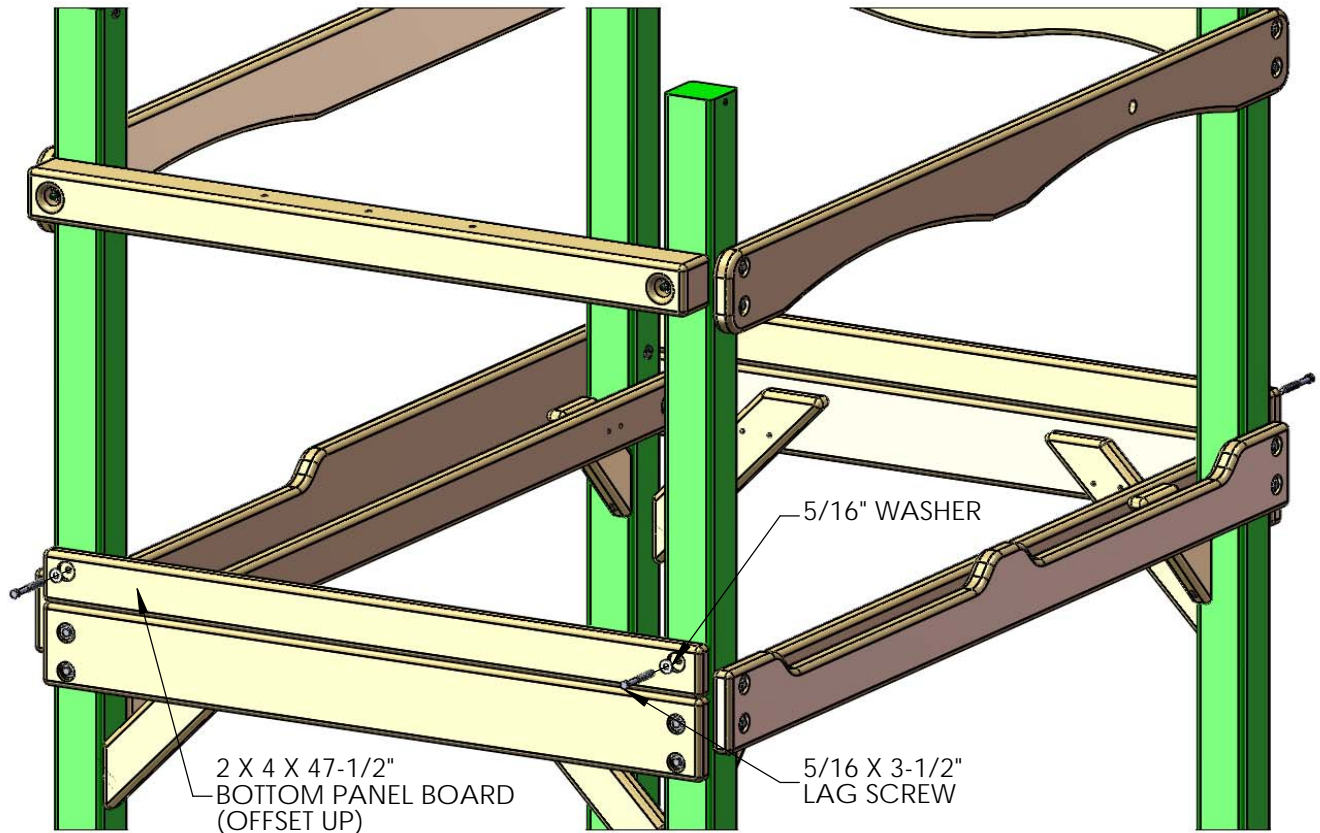

2: PLACE THE 2 X 4 X 47-1/2" BOTTOM PANEL BOARD ON TOP OF THE 2 X 6 PANEL BOARD WITH OFFSET HOLES UP AND FASTEN TO THE CORNER POSTS WITH 5/16 X 3-1/2" LAG SCREWS WITH 5/16" WASHERS.

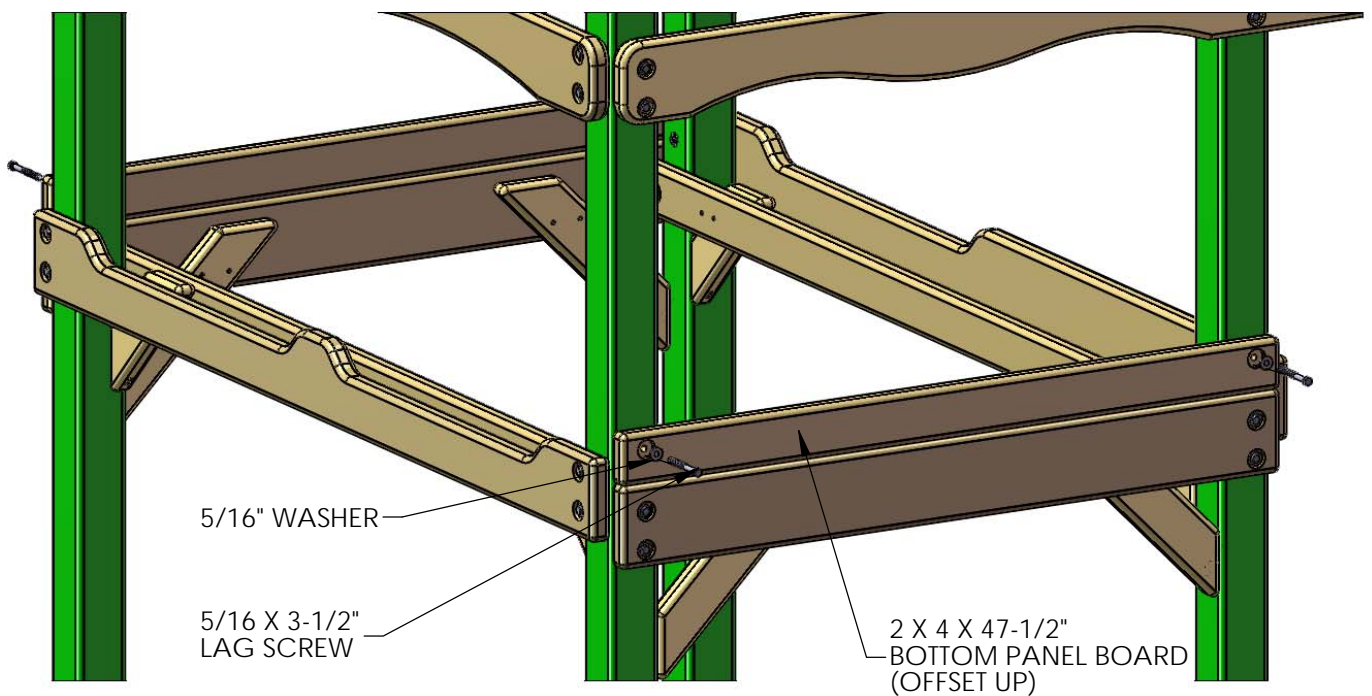

STEP 11: DECK SPACERS

THE FOLLOWING STEP IS RECOMMENDED TO PREVENT POSSIBLE SPLITS IN THE WOOD

1: PRE-DRILL THE ENDS OF THE 5/4 X 4 X 40-1/2" DECK SPACERS TO PREVENT INSTALLATION DAMAGE. PRE-DRILL BOTH ENDS WITH A 1/8" DRILL BIT AT THE DIMENSIONS SHOWN BELOW. THE HOLE AT 20-1/4" ONLY NEEDS TO BE DRILLED ONCE. THIS HOLE IS TO ATTACH THE CENTER DECK SUPPORT TO THE DECK SPACER.

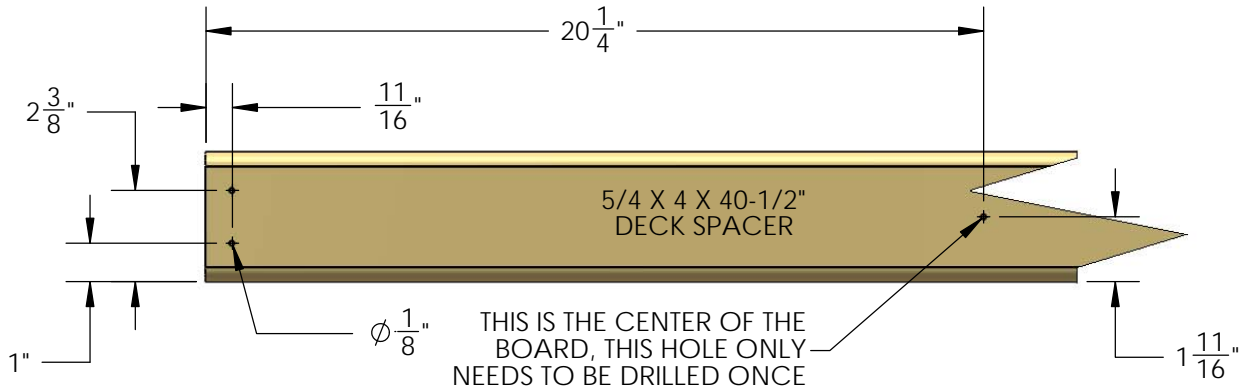

2: PLACE THE 5/4 X 4 X 40-1/2" DECK SPACER AT ONE END OF THE FORT. CENTER THE BOARD BETWEEN THE CORNER POSTS AND ATTACH IT WITH 2" WOOD SCREWS THROUGH THE PREDRILED HOLES AND INTO THE DECK SUPPORT BELOW. NOTE: THE TOP OF THE SCREW HEAD SHOULD BE FLUSH TO THE TOP OF THE DECK SPACER.

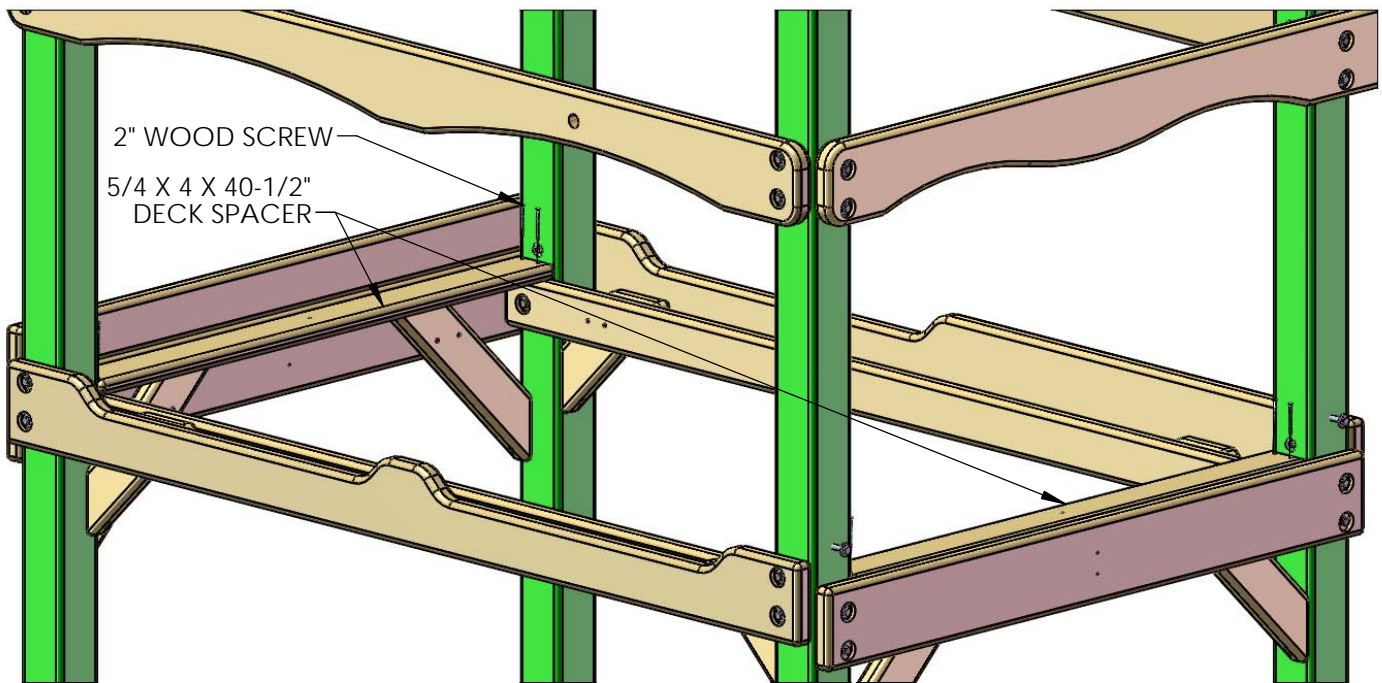

2 X 4 X 47-1/2" BOTTOM PANEL BOARD
REMOVED FROM VIEW FOR CLARITY

STEP 12: CENTER DECK SUPPORT

- 1: FIND THE 2 X 4 X 70" CENTER DECK SUPPORT WITHOUT HOLES.
- 2: PLACE THE CENTER DECK SUPPORT UNDERNEATH THE CENTER OF THE DECK SPACERS. (USE THE HOLE AT THE CENTER AS A GUIDE)
- 3: USE 2" WOOD SCREWS TO ATTACH THE DECK SPACERS TO THE CENTER DECK SUPPORT.
- 4: USE THE HOLE AT THE CENTER OF THE DECK SUPPORT AS A GUIDE TO MAKE A MARK ON THE OUTSIDE OF THE FORT TO REPRESENT A CENTER LINE. MAKE SURE THE 2 X 4 X 70" CENTER DECK SUPPORT IS LINED UP ON THESE MARKS.
- 5: INSTALL TWO 2-1/2" WOOD SCREWS INTO THE 2 X 4 X 70" CENTER DECK SUPPORT THROUGH THE OUTSIDE OF THE 2 X 6. REPEAT THIS STEP ON THE OPPOSITE END OF THE FORT.

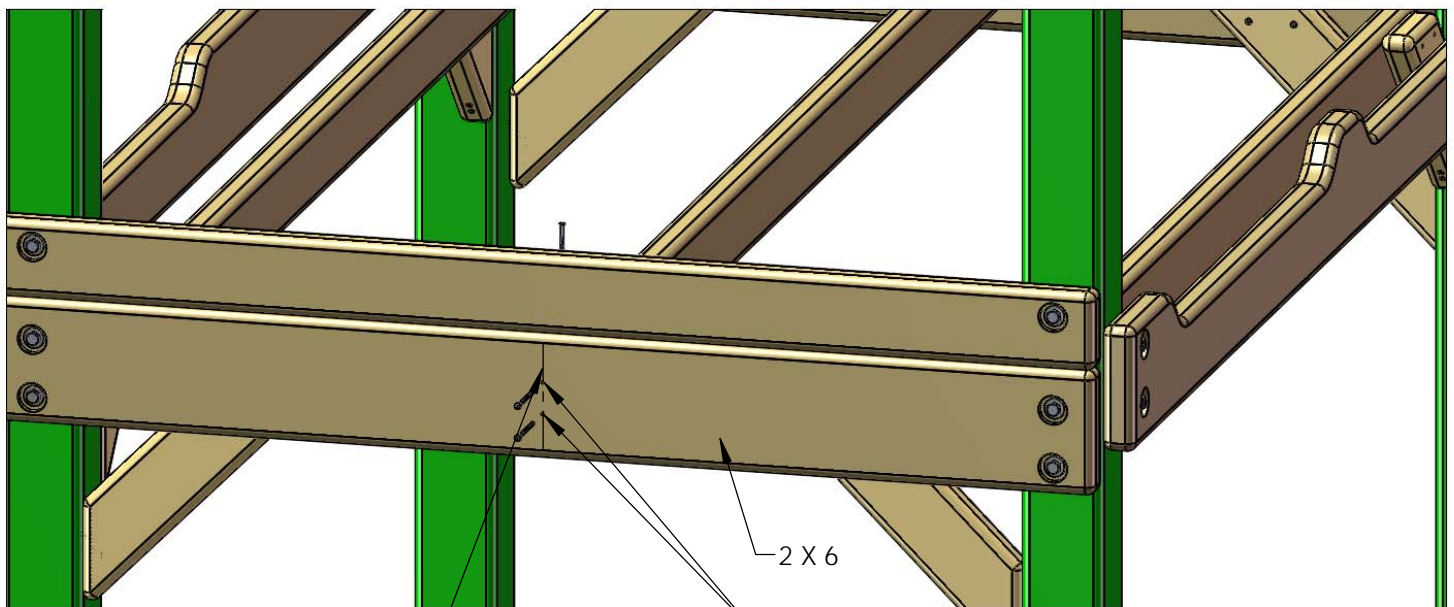
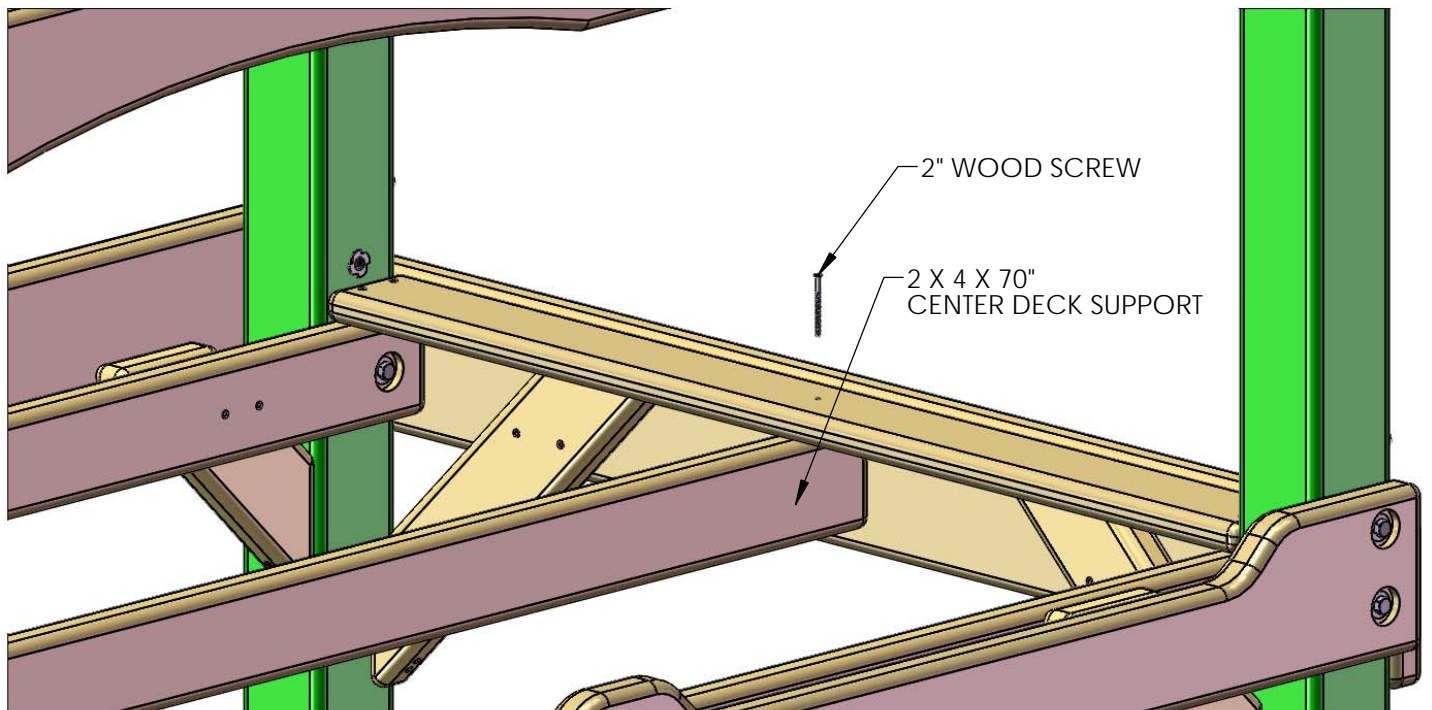

USE HOLE IN DECK SPACER TO MAKE A CENTER MARK HERE AND ON OTHER END OF FORT.

STEP 13: DECK BOARDS

THE FOLLOWING STEP IS RECOMMENDED TO PREVENT POSSIBLE SPLITS IN THE WOOD

1: PRE-DRILL THE ENDS OF THE DECK BOARDS TO PREVENT INSTALLATION DAMAGE. PRE-DRILL BOTH ENDS WITH A 1/8" DRILL BIT AT THE DIMENSIONS SHOWN BELOW.

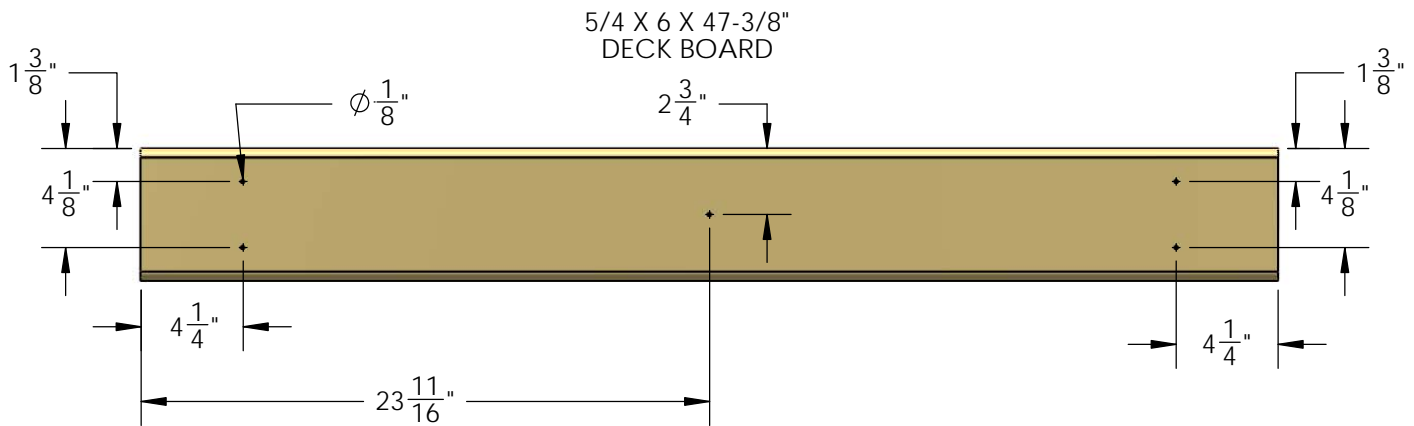

2: START WITH A 5/4 X 6 X 47-3/8" DECK BOARD AT ONE END OF THE FORT. CENTER THE BOARD BETWEEN THE FRONT DECK PANEL BOARD AND THE REAR DECK PANEL BOARD AND ATTACH IT WITH 2" WOOD SCREWS THROUGH THE PREDRILED HOLES AND INTO THE DECK SUPPORT BELOW. LEAVE A UNIFORM (APPROX. 1/4") SPACE BETWEEN THE DECK BOARDS. NOTE: THE TOP OF THE SCREW HEAD SHOULD BE FLUSH TO THE TOP OF THE DECK BOARDS.

LAY ALL DECK BOARDS ACROSS THE DECK SUPPORTS BEFORE SECURING THEM TO THE FORT. THIS WILL ENSURE THAT YOU HAVE EQUAL SPACING ACROSS THE DECK.

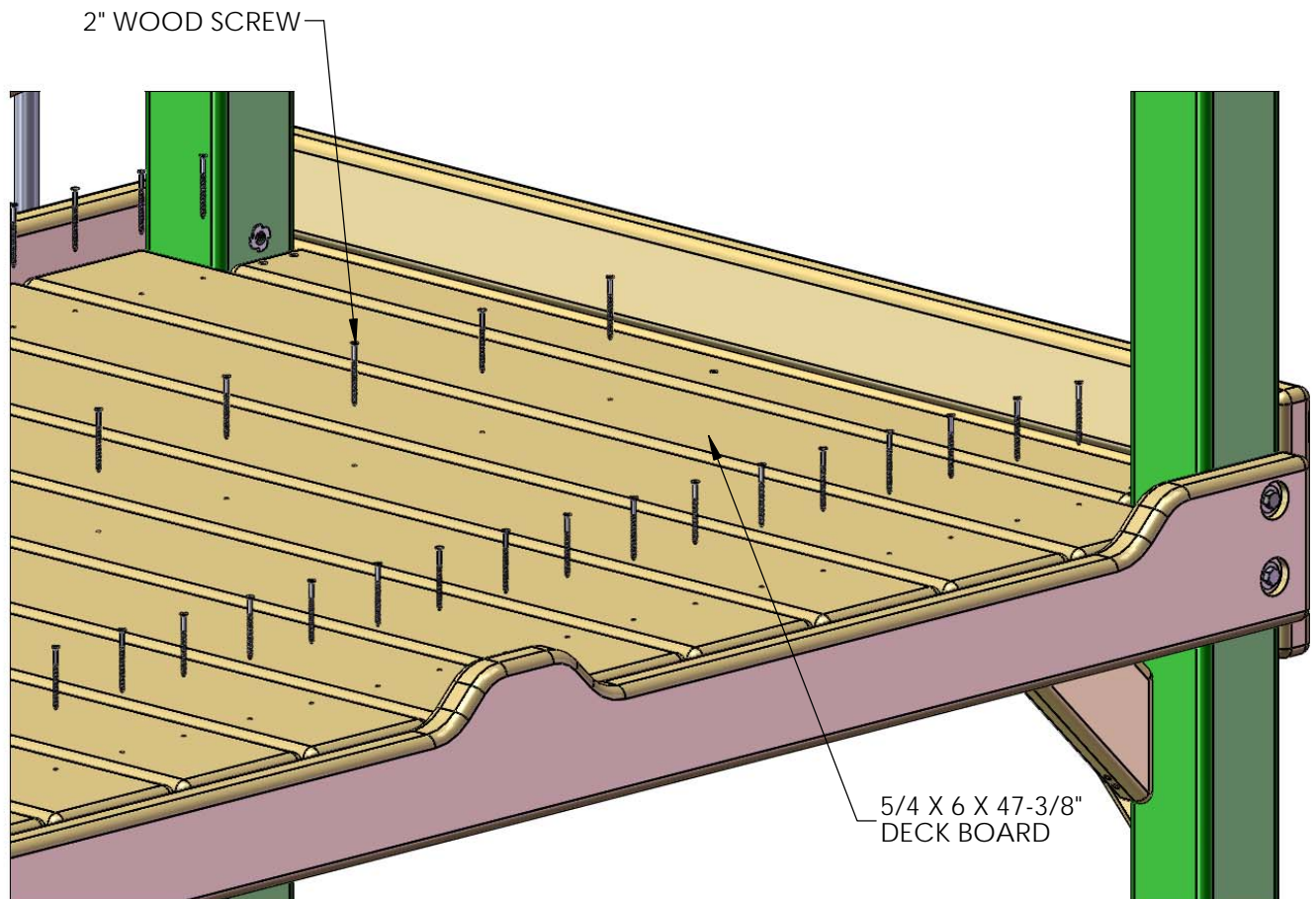

STEP 14: ROCK WALL BOARD IDENTIFICATION

1: EVERY EFFORT HAS BEEN MADE TO PRE-LABEL YOUR ROCK WALL BOARDS PROPERLY. ROCK WALL BOARDS 1, 2 AND 3 SHOULD HAVE THE NUMBERS 1, 2 OR 3 PRINTED ON THE ENDS OF THE BOARDS. IN THE EVENT THAT A ROCK WALL BOARD DOES NOT HAVE ANY IDENTIFYING MARKS USE THIS CHART AS A GUIDE TO IDENTIFY THE BOARD.

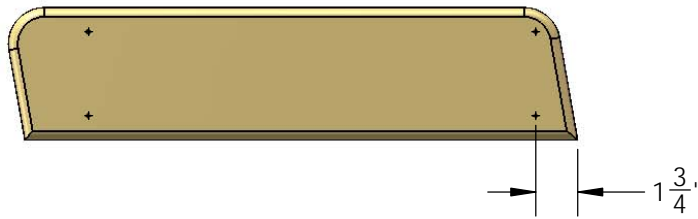

TOP ROCK WALL BOARD
(ROUNDED TOP CORNERS)
125-6-2368-TRWB
QUANTITY: 1

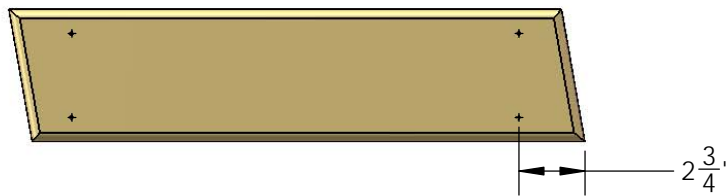

ROCK WALL BOARD 1
125-6-2397-RWB1
QUANTITY: 4

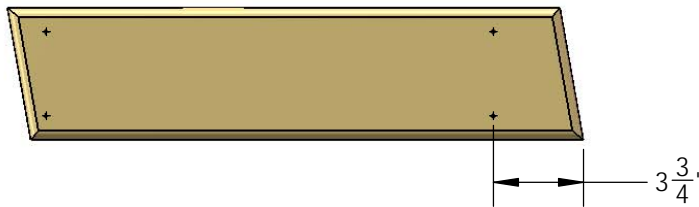

ROCK WALL BOARD 2
125-6-2397-RWB2
QUANTITY: 4

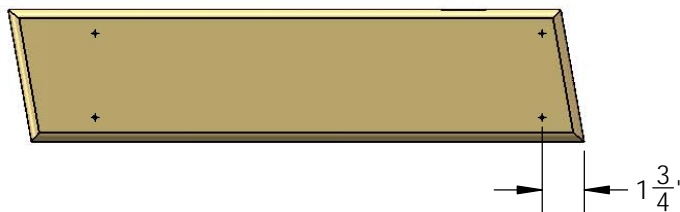

ROCK WALL BOARD 3
125-6-2397-RWB3
QUANTITY: 2

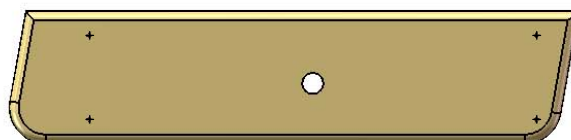

BOTTOM ROCK WALL BOARD
(ROUNDED BOTTOM CORNERS
AND HOLE)
125-6-2368-BRWB
QUANTITY: 1

STEP 15: ROCK WALL BOARD LAYOUT

1: LAY ALL THE ROCK WALL BOARDS OUT ON A FLAT SURFACE AS SHOWN BELOW. YOU ARE LOOKING AT THE BACK SIDE OF THE ROCK WALL.

2: PLACE THE 1 X 2 X 62-1/2" BATTEN ON THE BACK SIDE AS SHOWN. FASTEN THE BATTEN TO THE ROCK WALL BOARDS WITH #8 X 1-1/2" WOOD SCREWS.

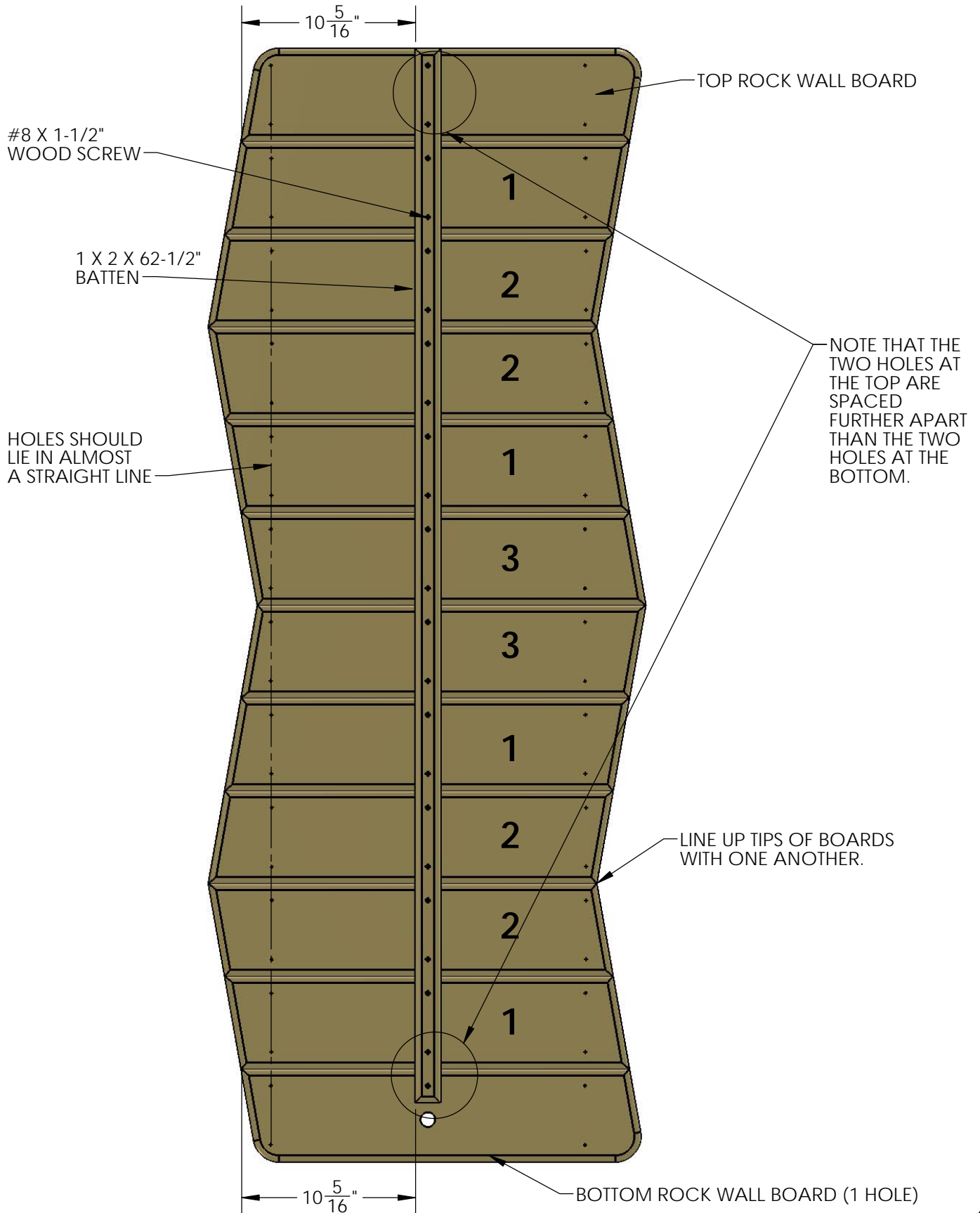

STEP 16: ROCK WALL SIDES

- 1: LOCATE TWO 2 X 4 X 66" ROCK WALL SIDES.
- 2: POSITION THE ROCK WALL SIDES SO THAT THE HOLES IN THE BOARDS ARE BOTH FACING THE SAME WAY.
- 3: INSERT T-NUTS INTO THE INSIDE OF THE ROCK WALL SIDES AND SET WITH A HAMMER.

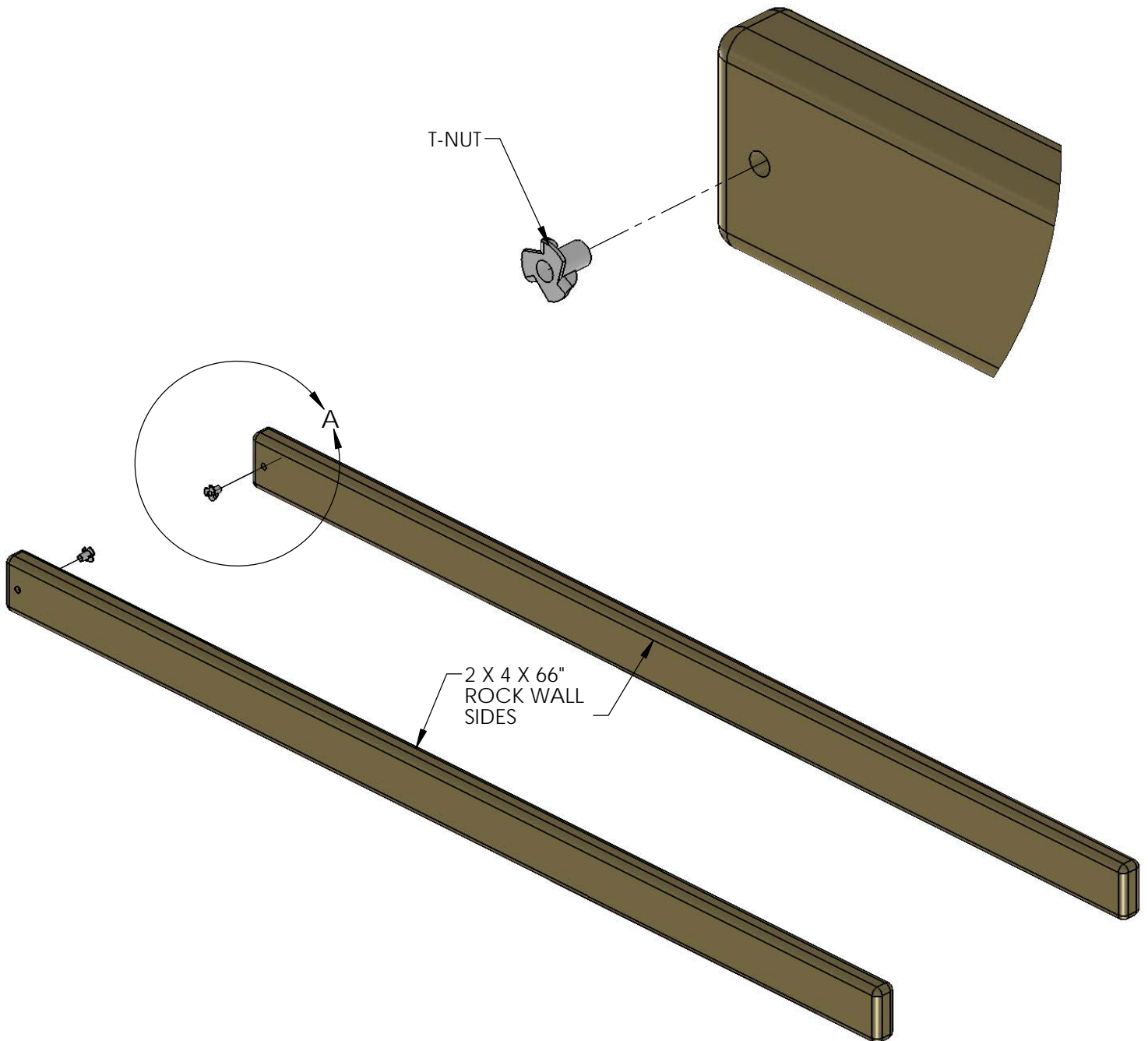

STEP 17: ROCK WALL BOARDS

1: LAY OUT THE ROCK WALL SIDES ON THE FLAT SURFACE BESIDE THE ROCK WALL ASSEMBLY. THE OUTSIDE SURFACES OF THE ROCK WALL SIDES SHOULD BE 20 INCHES APART. T-NUTS SHOULD BE ON THE INSIDE OF THE ROCK WALL SIDES.

2: FLIP THE ROCK WALL ASSEMBLY OVER SO THAT THE BATTEN IS FACING THE GROUND. PLACE THE ROCK WALL ASSEMBLY ON TOP OF THE ROCK WALL BOARDS.

3: CENTER THE HOLES IN THE ROCK WALL BOARDS OVER THE CENTER OF THE ROCK WALL SIDES. THE TOP ROCK WALL BOARD MUST BE FLUSH TO THE ENDS OF THE 2 X 4 X 66" ROCK WALL SIDES.

4: ATTACH THE ROCK WALL BOARDS TO THE ROCK WALL SIDES WITH #8 X 2" WOOD SCREWS.

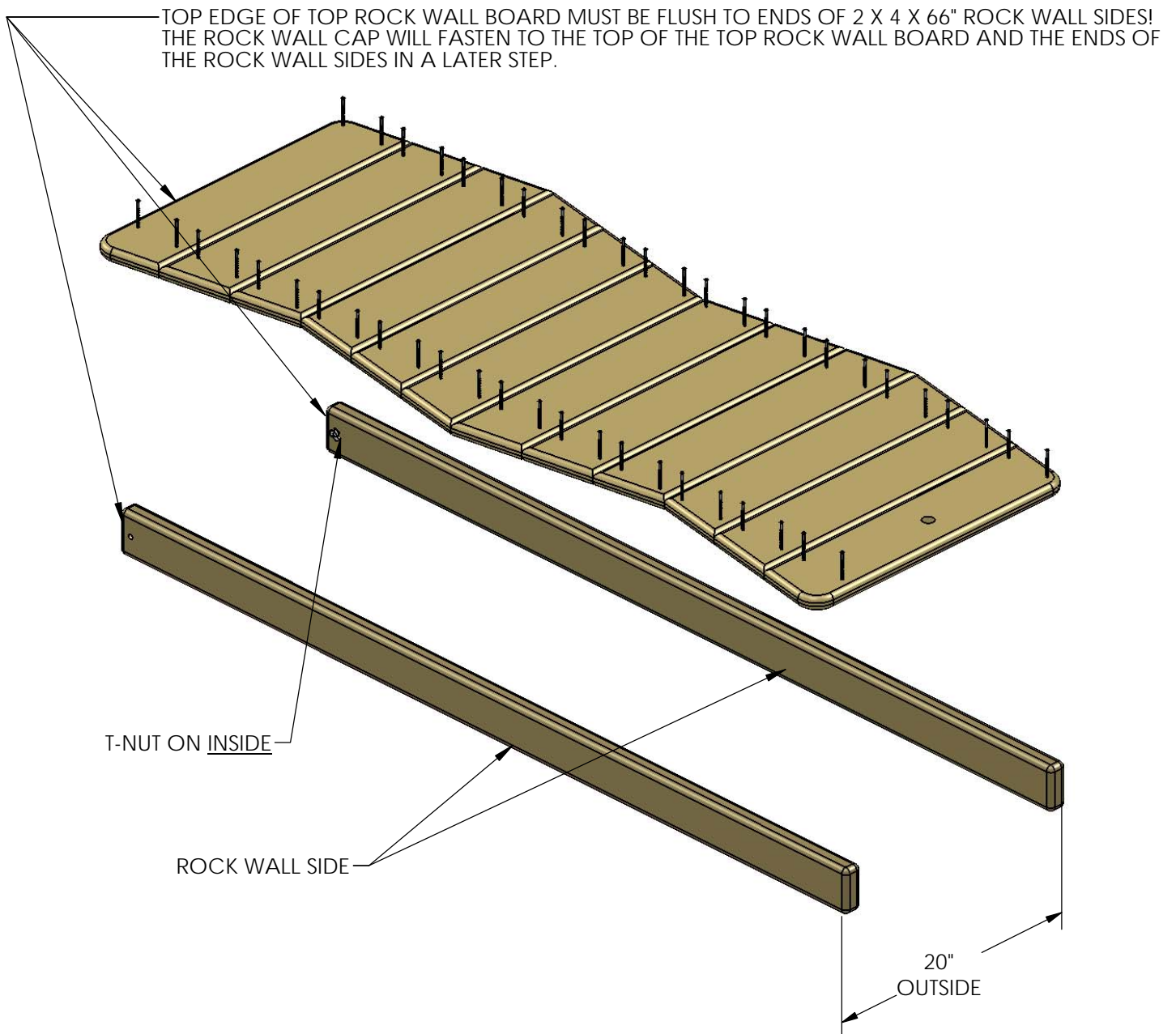

STEP 18: ROCK WALL BRACKETS

1: FASTEN THE 90° GREEN BRACKET TO THE ROCK WALL SIDES WITH 5/16" X 1-1/2" HEX BOLTS AND 5/16" WASHERS.

2: DO NOT FULLY TIGHTEN THE HEX NUTS INTO THE T-NUTS AT THIS TIME.

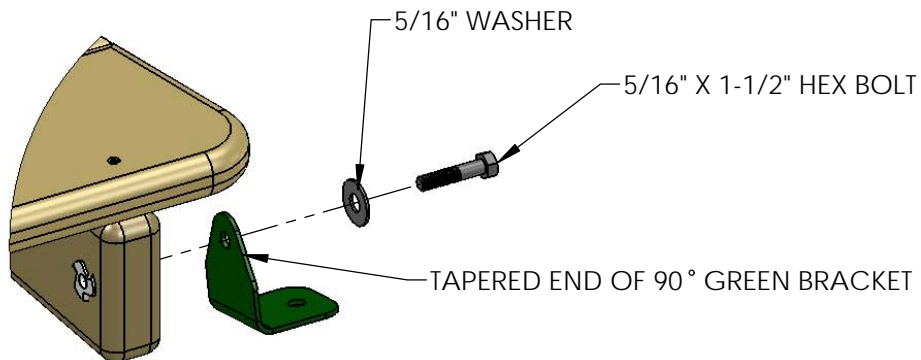
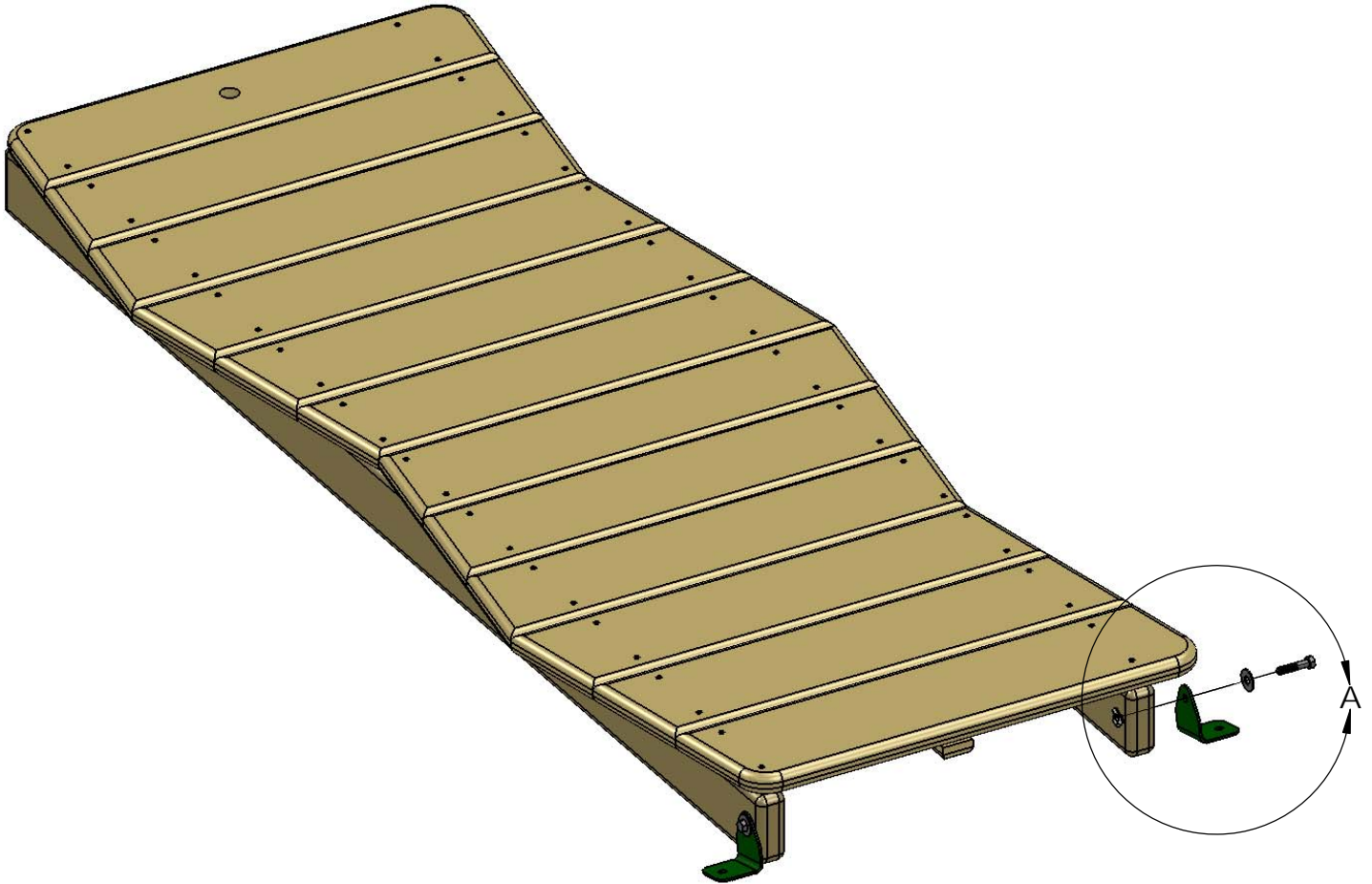

STEP 19: ROCK WALL ROCKS

1: LOCATE TEN ROCK WALL ROCKS WITH HARDWARE INCLUDED.

2: MOUNT THE ROCKS IN A STAGGERED PATTERN ON THE ROCK WALL BOARDS. ATTACH EACH ROCK WALL ROCK TO THE ROCK WALL BOARDS WITH THE PAN HEAD SCREWS AND WASHERS PROVIDED WITH THE ROCKS.

NOTE: THE IMAGE SHOWN BELOW IS A GENERIC ARRANGEMENT OF ROCKS ON THE ROCK WALL. YOUR ACTUAL PATTERN MAY BE DIFFERENT FROM WHAT YOU SEE BELOW.

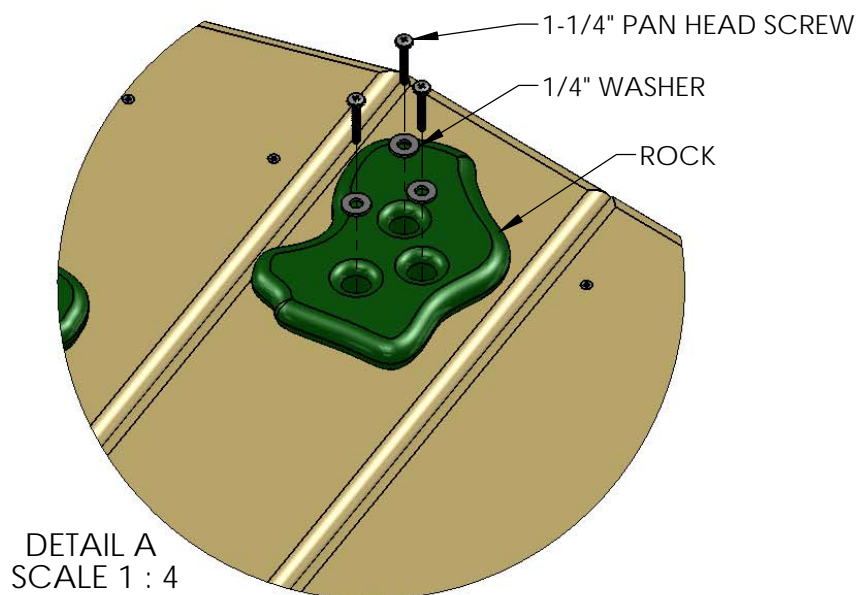
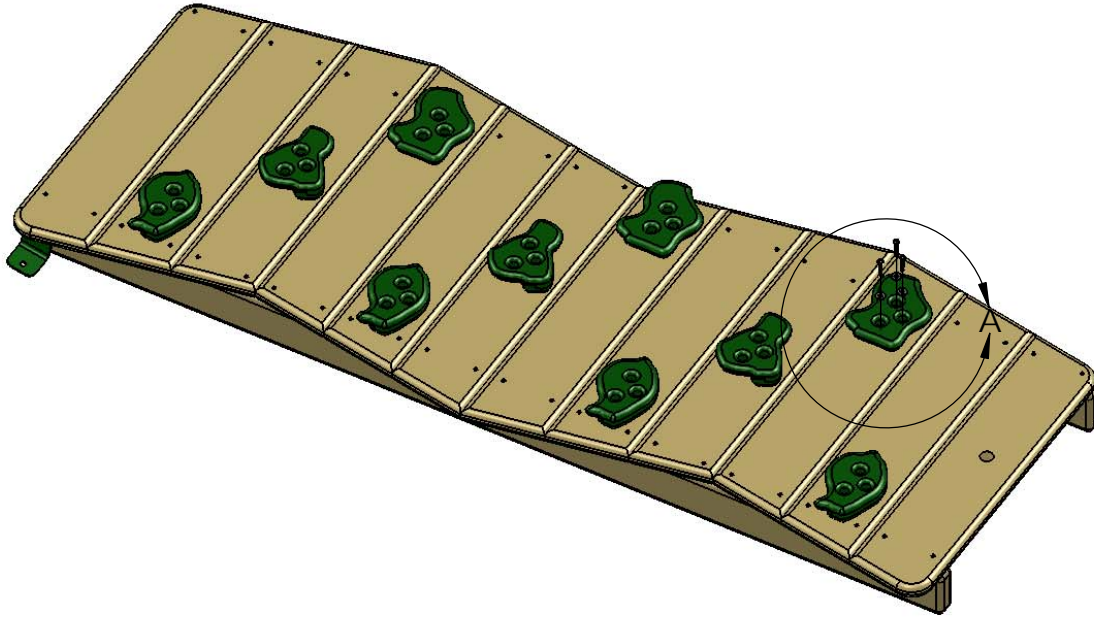

DETAIL A
SCALE 1 : 4

STEP 20: ROCK WALL TOP CAP

1: PLACE THE 5/4 X 3 X 21" ROCK WALL TOP CAP AT THE TOP OF THE ROCK WALL AS SHOWN.

2: ONE END OF THE ROCK WALL TOP CAP WILL EXTEND PAST THE ROCK WALL SIDE AS SHOWN BELOW. THE OUTSIDE FACE OF THE TOP ROCK WALL BOARD WILL BE FLUSH TO THE FRONT SURFACE OF THE ROCK WALL TOP CAP; SEE "FLUSH" BELOW.

3: FASTEN THE ROCK WALL TOP CAP TO THE TOP ROCK WALL BOARD AND THE ROCK WALL SIDES WITH #8 X 2" WOOD SCREWS.

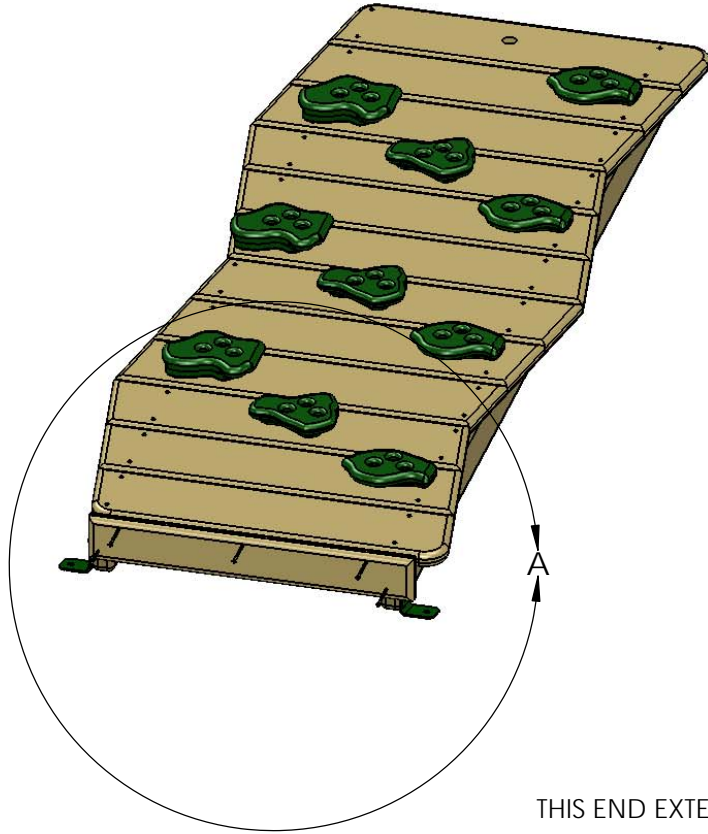

THIS END EXTENDS PAST THE SIDE OF THE ROCK WALL SIDE.

THIS END IS FLUSH TO THE SIDE OF THE ROCK WALL SIDE.

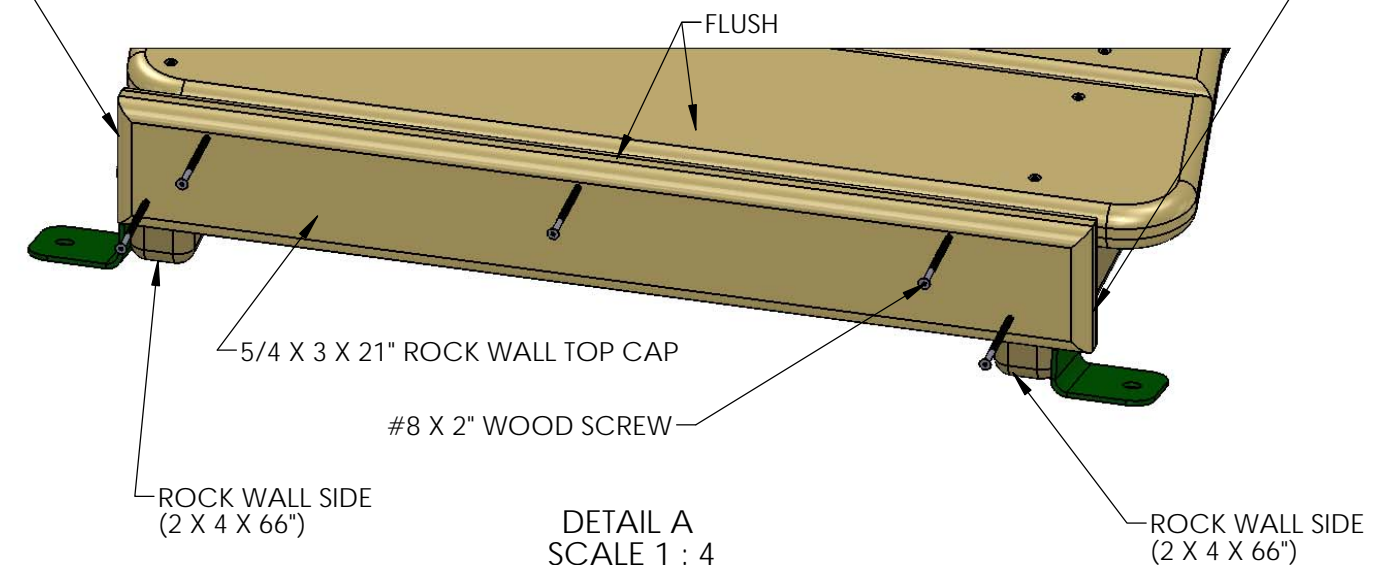

STEP 21: ATTACHING THE ROCK WALL

1: PLACE THE ROCK WALL INTO POSITION ON THE FORT AS SHOWN BELOW; THE ROCK WALL SIDE IS 9-3/4" FROM THE END OF THE DECK PANEL BOARD. USING THE 90° BRACKETS AS A TEMPLATE; DRILL A 3/8" HOLE THROUGH THE DECK PANEL BOARD. THE BOTTOM OF THE GREEN BRACKETS SHOULD BE APPROXIMATELY 3/4" FROM THE BOTTOM OF THE DECK PANEL BOARD.

2: FROM THE UNDERSIDE OF THE DECK INSERT A T-NUT INTO THE BACKSIDE OF THE 3/8" HOLES ON THE DECK PANEL BOARD.

3: ATTACH THE ROCK WALL WITH 5/16 X 1-1/2" BOLTS AND 5/16" WASHERS.

4: WHEN THE BRACKETS ARE SECURE, AND THE ROCK WALL IS IN ITS FINAL POSITION; TIGHTEN THE 5/16 X 1-1/2" BOLTS ON THE ROCK WALL SIDES.

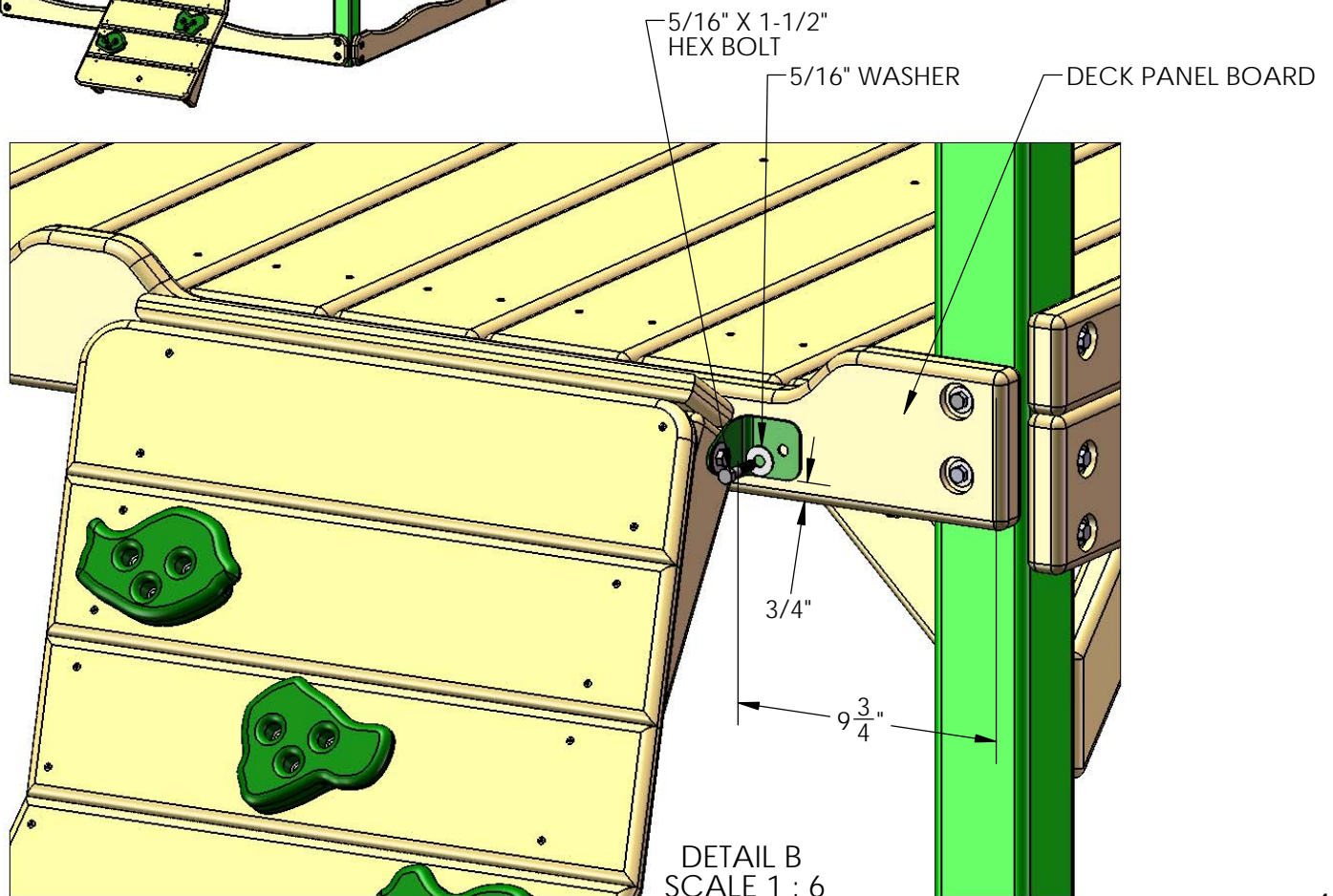
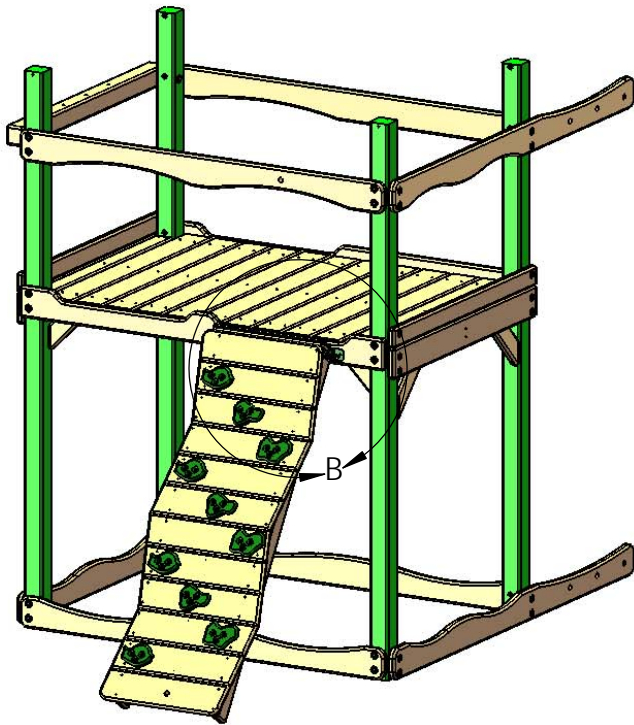

STEP 22: LADDER

1: FIND TWO 2 X 4 X 66" LADDER SIDES.

2: POSITION THE LADDER SIDES SO THAT THE SLOTS IN THE BOARDS ARE FACING EACH OTHER AND ARE PARALLEL.

3: INSERT T-NUTS INTO THE OUTSIDE OF THE LADDER SIDES AND SET WITH A HAMMER.

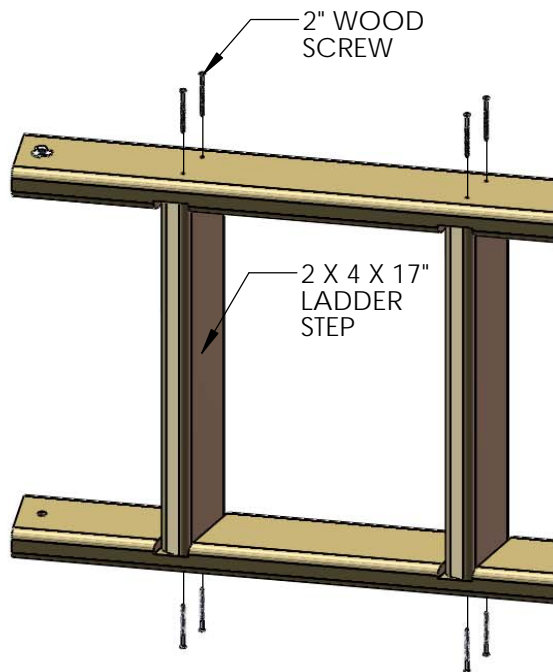
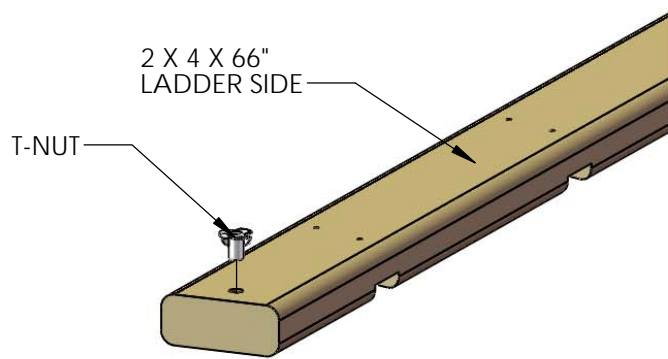

4: FIND FIVE 2 X 4 X 17" LADDER STEPS.

5: PLACE THE STEPS INTO THE SLOTS ON THE LADDER SIDES, AND FASTEN WITH 2" WOOD SCREWS.

6: CAREFULLY TURN THE LADDER OVER AND PUT THE SCREWS INTO THE OTHER SIDE.

7: INSTALL THE 90° ANGLE BRACKETS TO THE INSIDE OF THE LADDER RAILS WITH 5/16 X 1-1/2" BOLTS, 5/16 WASHERS, INTO THE 5/16" T-NUTS.

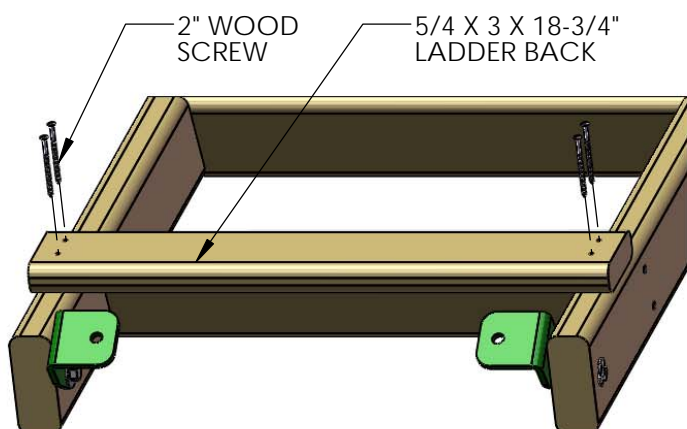
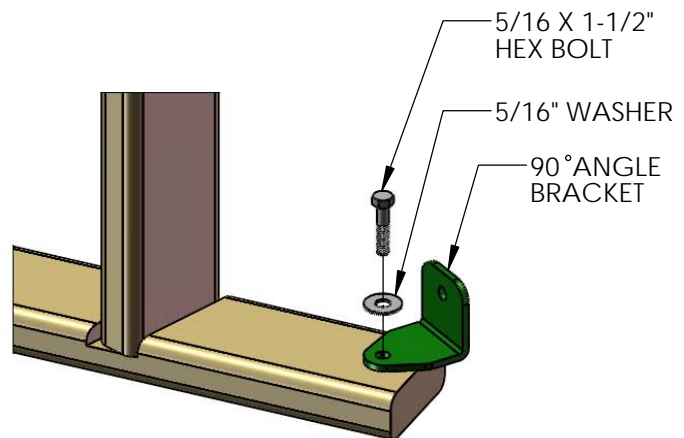

8: INSTALL THE 5/4 X 3 X 18-3/4" LADDER BACK ABOVE THE TOP STEP OF THE LADDER WITH TWO 2" WOOD SCREWS PER SIDE.

STEP 23: LADDER TO FORT

1: PLACE THE LADDER INTO POSITION ON THE REAR OF THE FORT AS SHOWN BELOW; THE SIDE OF THE LADDER SHOULD BE 10-1/2" FROM THE OUTSIDE OF THE CORNER POST. THE BOTTOM OF THE 90 DEGREE BRACKETS SHOULD BE 3/4" ABOVE THE BOTTOM OF THE REAR DECK PANEL BOARD.

2: USING THE LADDER BRACKETS AS A TEMPLATE, DRILL A 3/8" HOLE THROUGH THE REAR DECK PANEL BOARD.

3: FROM THE UNDERSIDE OF THE DECK INSERT A T-NUT INTO THE BACKSIDE OF THE 3/8" HOLES ON THE REAR DECK PANEL BOARD.

4: ATTACH THE LADDER WITH 5/16 X 1-1/2" BOLTS AND 5/16" WASHERS.

5: WHEN THE BRACKETS ARE SECURE, AND THE LADDER IS IN ITS FINAL POSITION; TIGHTEN THE 5/16 X 1-1/2" BOLTS ON THE LADDER SIDES.

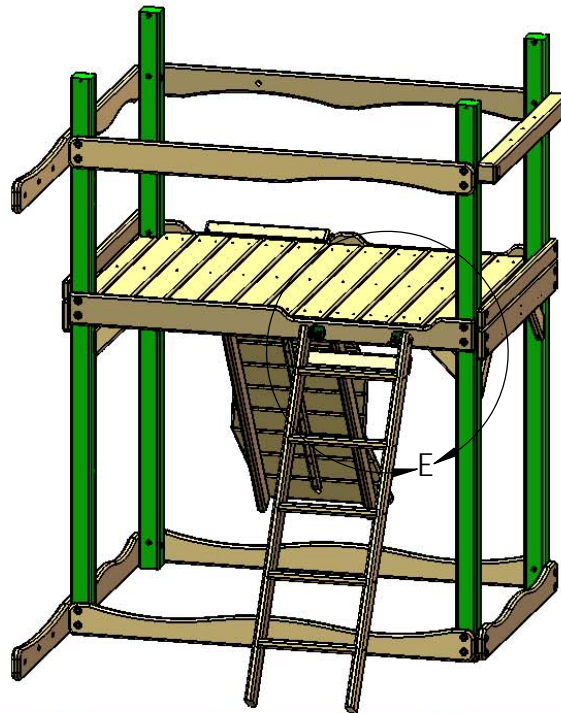

5/16" X 1-1/2"
HEX BOLT

5/16" WASHER

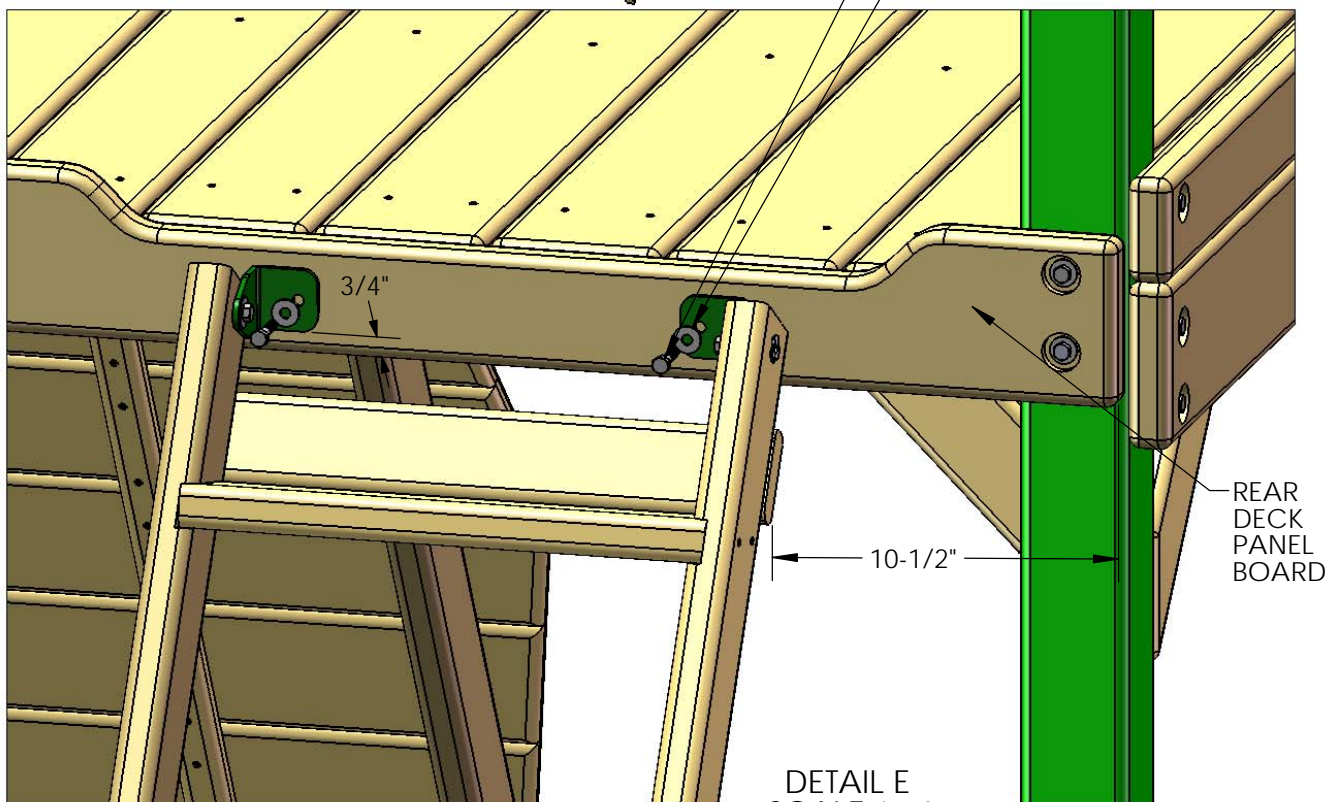

DETAIL E
SCALE 1 : 6

STEP 24: PANEL SLATS

- 1: FIND TWENTY-FOUR 5/4 X 2-5/8 X 28-1/2" PANEL SLATS.
- 2: PRE-DRILL THE SLATS 1" FROM EACH END ON CENTER WITH A 1/8" DRILL BIT.
- 3: INSTALL THE PANEL SLATS AT EQUAL LENGTHS. SEE DETAIL BELOW FOR MEASUREMENTS.
- 4: ATTACH THE PANEL SLATS TO THE FORT WITH 2" WOOD SCREWS IN THE PRE-DRILLED HOLES.

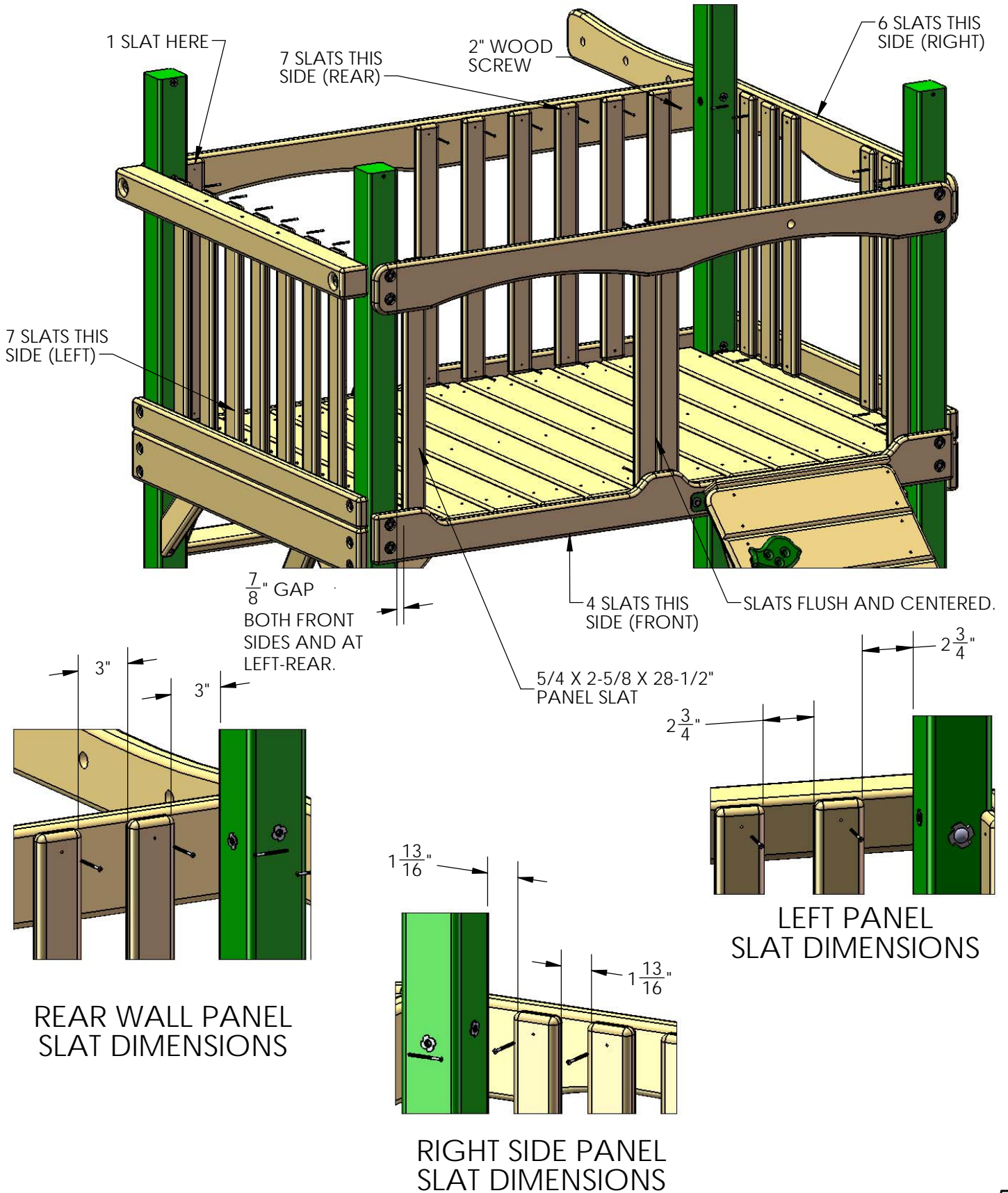

STEP 26: ROOF PEAK SUPPORTS

1: PLACE A 5/4 X 6 X 10-3/4" ROOF PEAK SUPPORT ON THE OUTSIDE OF THE ROOF SUPPORTS.

2: LEVEL THE ROOF PEAK SUPPORT. MAKE SURE THE ANGLED SURFACES ARE FLUSH OR SLIGHTLY BELOW THE TOP SURFACES OF THE ROOF SUPPORTS.

3: USE #8 X 2" WOOD SCREWS IN THE THE PREDRILLED HOLES TO ATTACH THE ROOF PEAK SUPPORTS TO THE ROOF SUPPORTS.

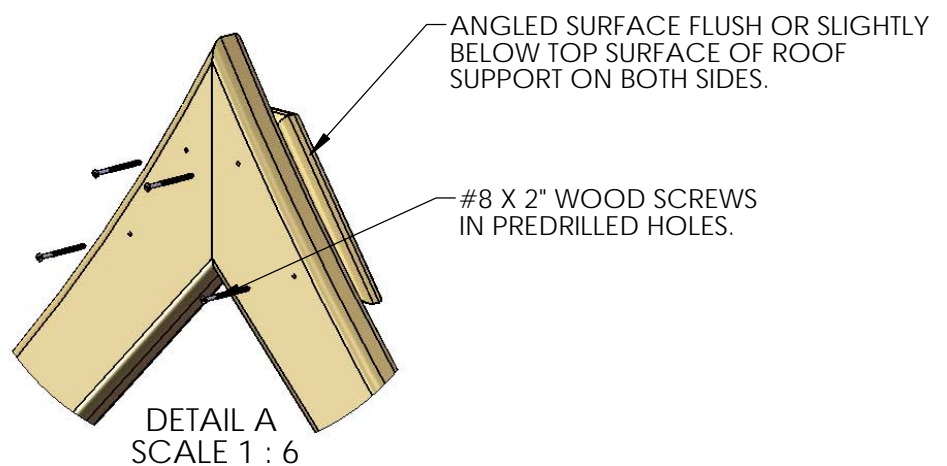
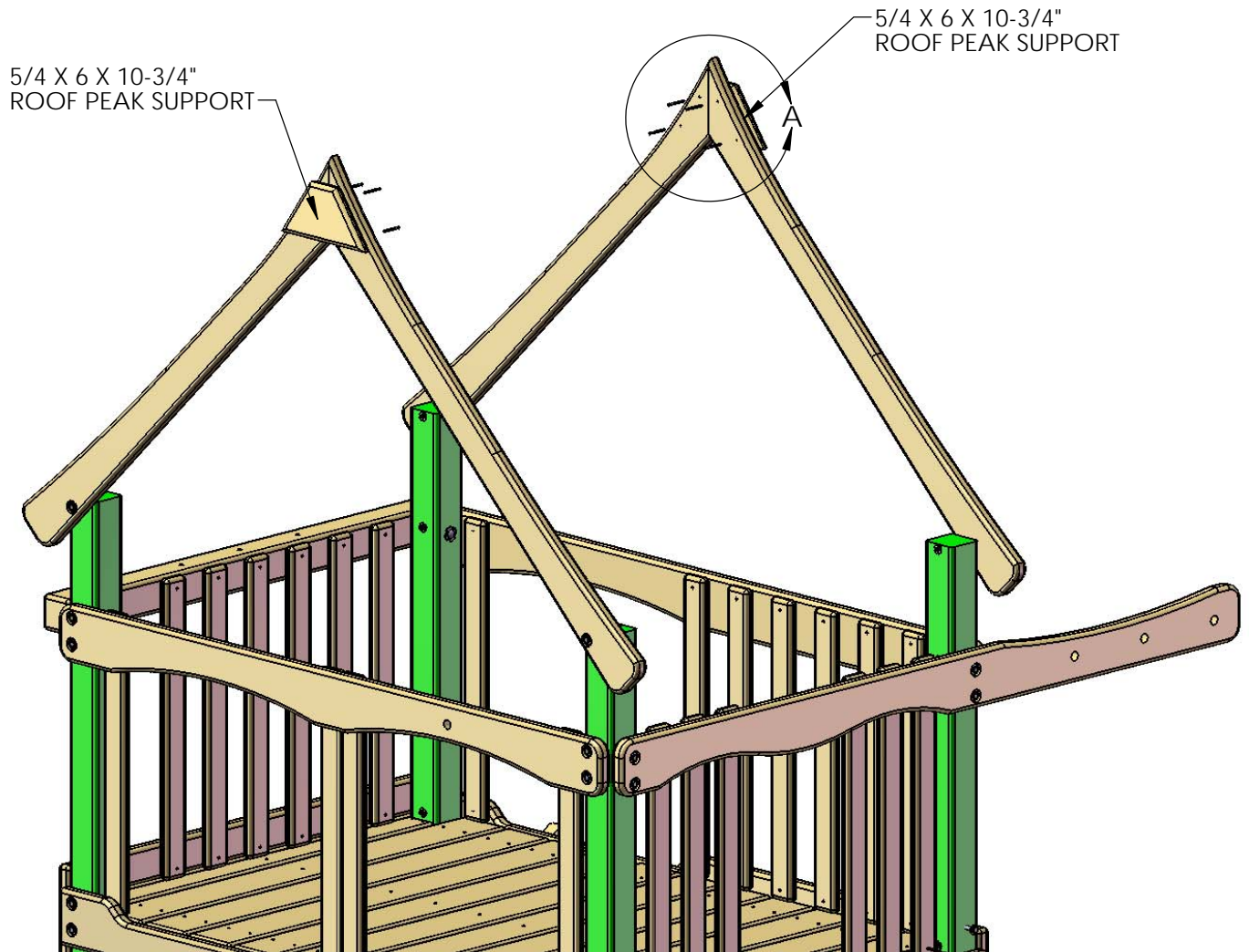

STEP 27: SWING BEAM PLATE

1: PLACE THE SWING BEAM PLATE ON TOP OF THE SWING BEAM SUPPORT, LINING UP THE PILOT HOLES.

2: FASTEN THE SWING BEAM PLATE TO THE SWING BEAM SUPPORT USING 3-1/2" CARRIAGE BOLTS ON TOP AND 3/8" LOCK NUTS WITH 3/8" WASHERS FROM UNDERNEATH, IN THE COUNTERBORED HOLES OF THE SWING BEAM SUPPORT. USE BOLT CAPS TO COVER ANY EXPOSED THREADS.

3: LEAVE THE MIDDLE HOLE EMPTY, IT WILL BE USED LATER.

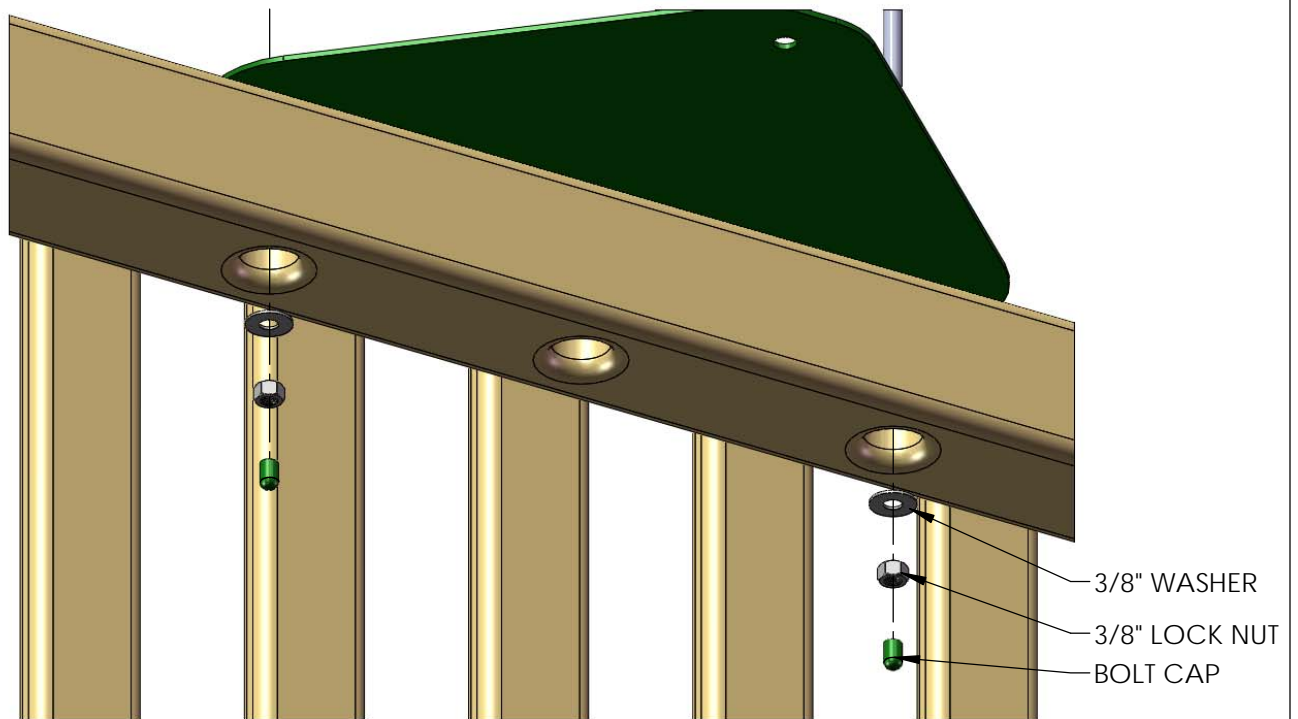
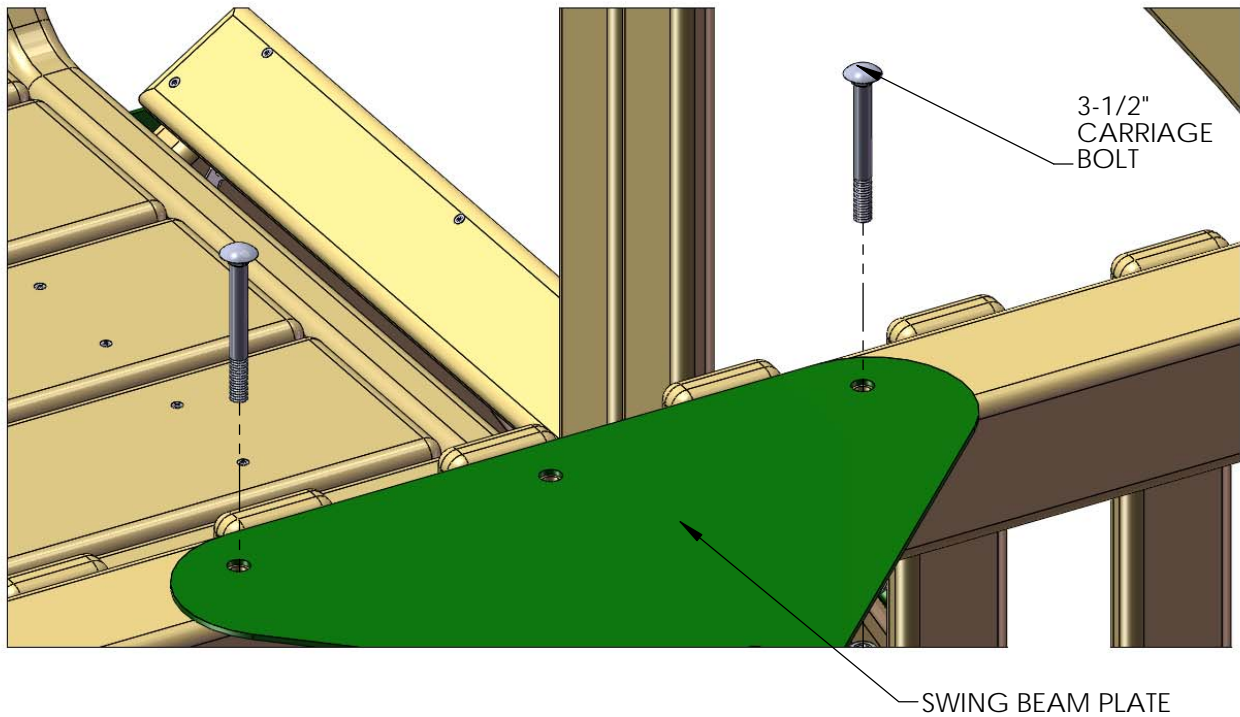

STEP 28: IRON DUCTILES

- 1: LINE UP THE HOLES OF THE IRON DUCTILE SWING HANGERS WITH THE HOLES IN THE SWINGBEAM.
- 2: FASTEN THE SWING HANGER TO THE SWING BEAM USING 7" CARRIAGE BOLTS WITH TORQUE WASHERS, AND 3/8" WASHERS WITH 3/8" LOCK NUTS.
- 3: PLACE BOLT CAPS OVER EXPOSED THREADS.

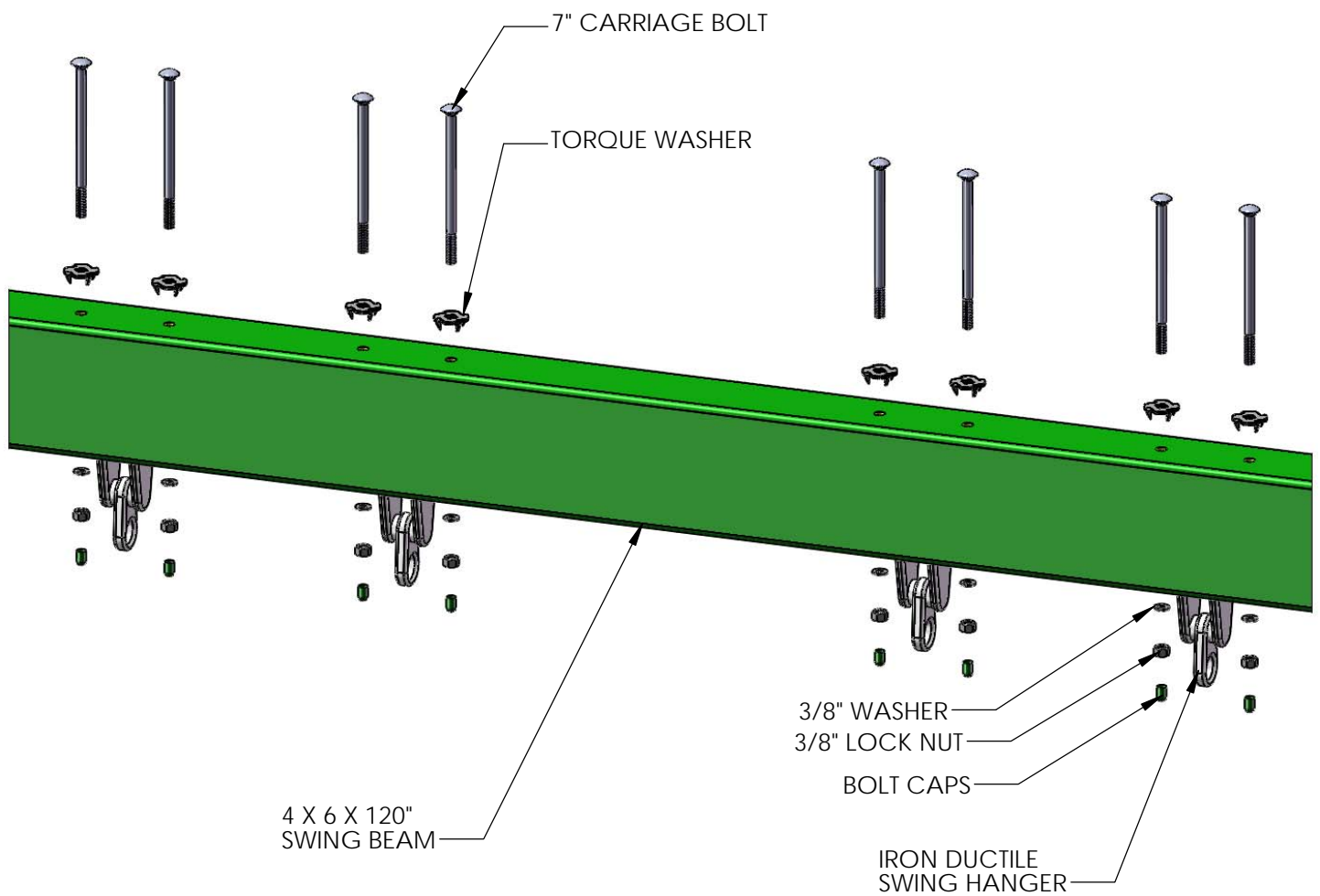

STEP 29: ATTACH SWING LEGS TO BRACKET

1: PLACE THE 4 X 4 X 108" SWING LEGS FLUSH TO THE TOP OF THE SWING LEG BRACKET.

2: FASTEN THE SWING LEGS TO THE SWING LEG BRACKET WITH 3/8 X 3-1/2" LAG SCREWS AND 3/8" WASHERS.

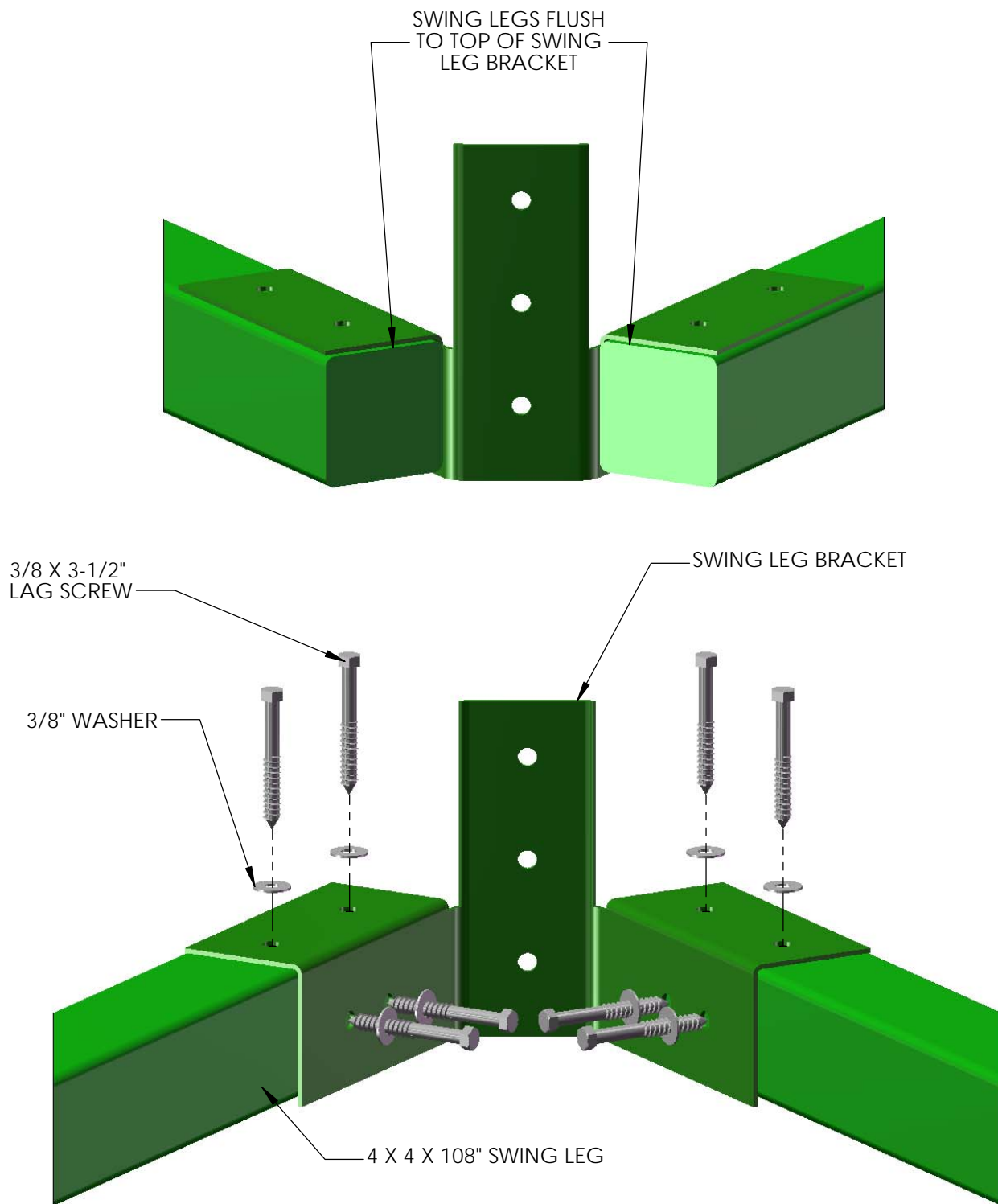

STEP 30: REST SWING BEAM ON FORT

AN EXTRA PERSON IS NEEDED FOR THIS STEP

1: SIT THE SWING BEAM LEGS UPRIGHT.

2: LINE UP THE PRE-DRILLED HOLES, AND REST THE SWING BEAM ON TOP OF THE FORT AND THE SWING BEAM LEGS. MAKE SURE THAT YOU HAVE THE BEAM FACING THE RIGHT WAY.

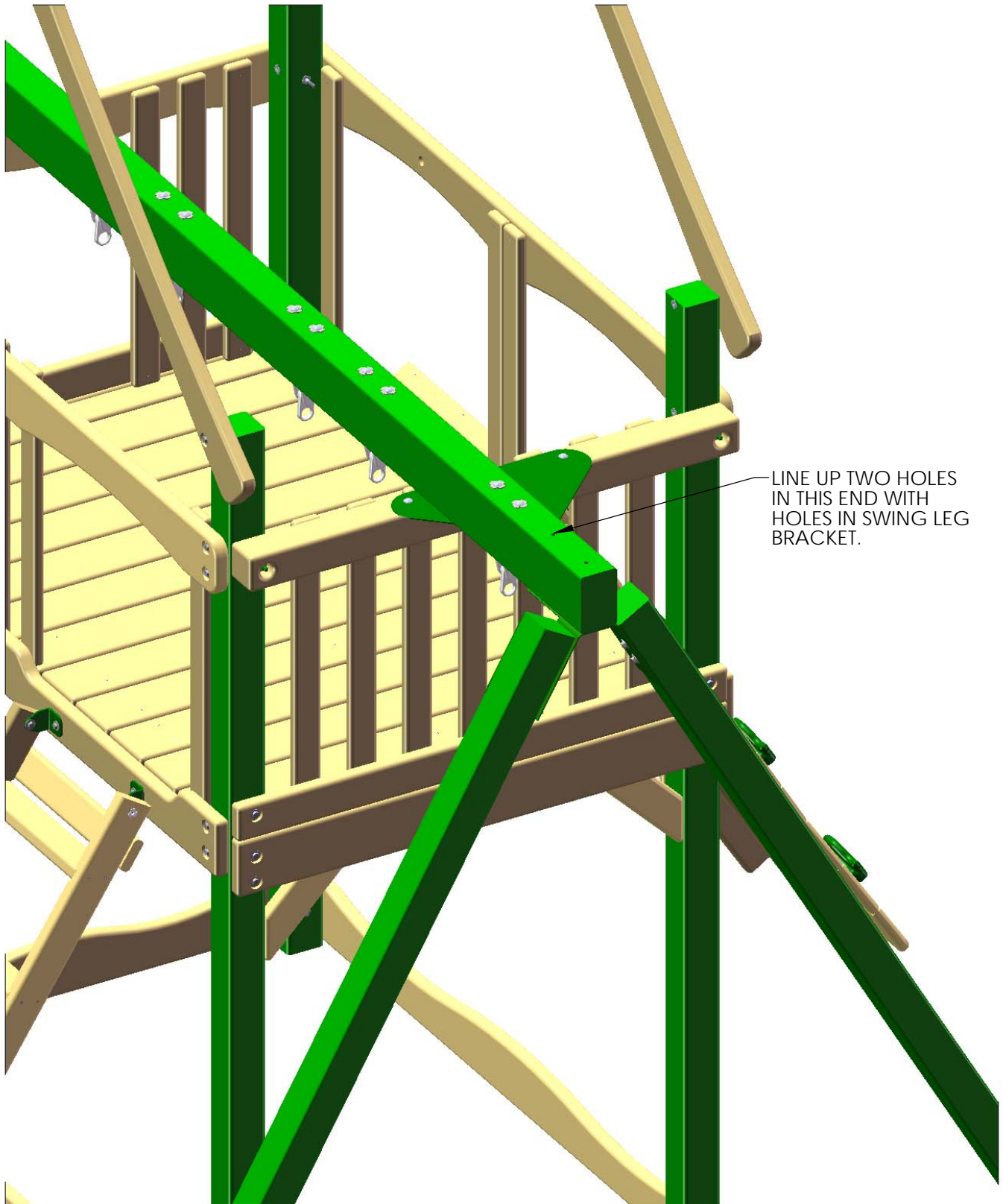

STEP 31: MOUNT SWING BEAM TO SWING BEAM LEGS

- 1: FASTEN THE SWING BEAM TO THE SWING BEAM BRACKET USING 7" CARRIAGE BOLTS WITH TORQUE WASHERS ON TOP OF THE SWING BEAM, AND 3/8" LOCK NUTS WITH 3/8" WASHERS FROM UNDERNEATH.
- 2: USE A 3/8 X 3-1/2" LAG SCREW WITH 3/8" WASHER FOR THE HOLE IN THE CENTER OF THE SWING BEAM BRACKET.
- 3: PLACE A BOLT CAP OVER ANY EXPOSED THREADS.

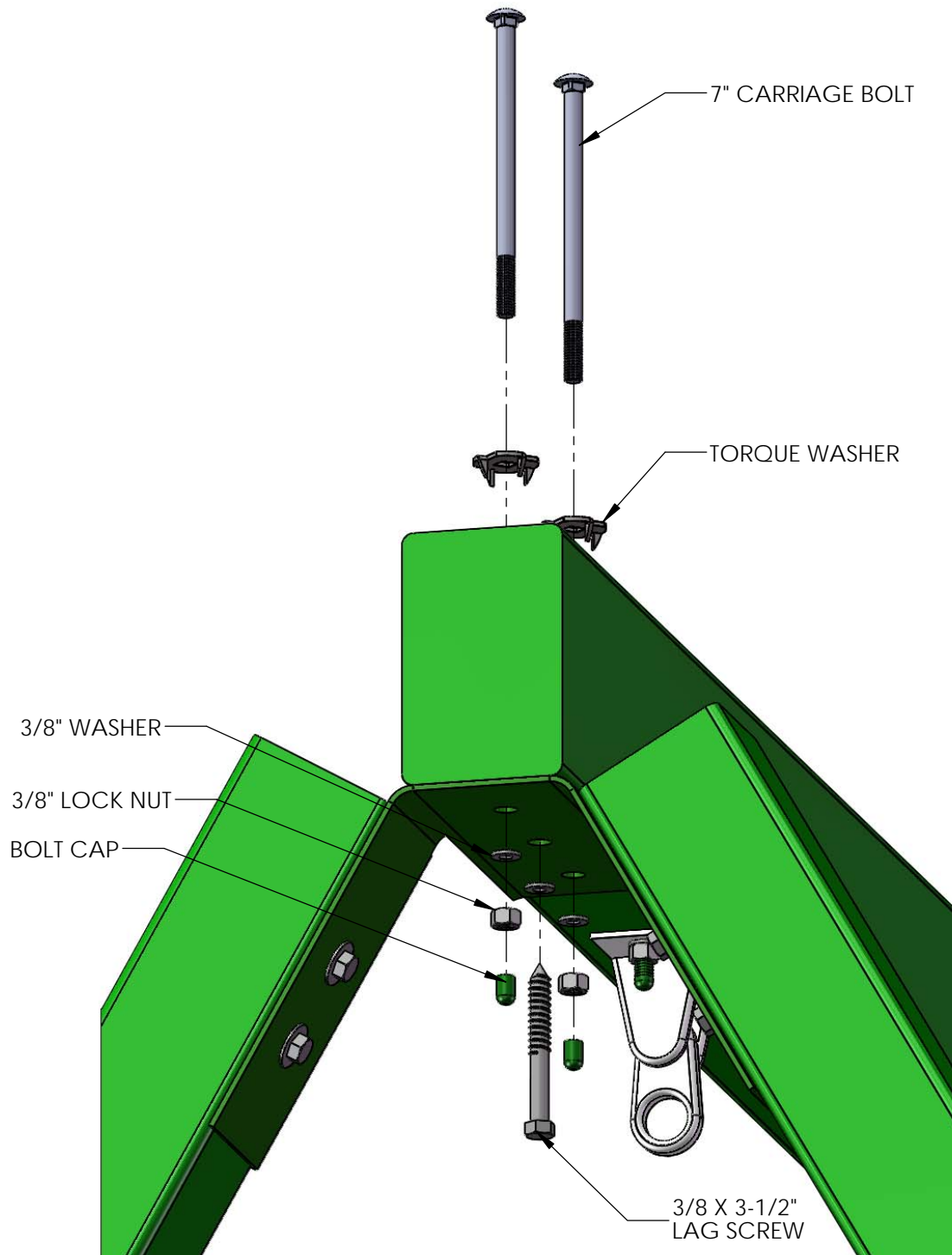

STEP 32: MOUNT SWING BEAM ON FORT

AN EXTRA PERSON IS NEEDED FOR THIS STEP

- 1: HAVE ONE PERSON WALK THE SWING BEAM OUT TO THE END OF THE FORT FROM INSIDE THE FORT WHILE THE OTHER PERSON CARRIES IT BY THE LEGS..
- 2: LINE UP THE PILOT HOLES AT THE END OF THE SWING BEAM WITH THE MIDDLE HOLES ON THE SWING BEAM PLATE.
- 3: FASTEN THE SWING BEAM TO THE SWING BEAM PLATE AND SWING BEAM SUPPORT USING A 9" CARRIAGE BOLT WITH A TORQUE WASHER ON TOP AND A 3/8" LOCK NUT AND WASHER ON THE BOTTOM. PLACE GREEN BOLT CAPS OVER EXPOSED THREADS AFTER SECURING.
- 4: FASTEN THE SWING BEAM TO THE SWING BEAM PLATE FROM UNDERNEATH WITH A 3/8 X 3-1/2" LAG SCREW AND 3/8" WASHER.
- 5: USE VISE GRIPS TO HOLD CARRIAGE BOLTS IN PLACE WHEN INSTALLING.

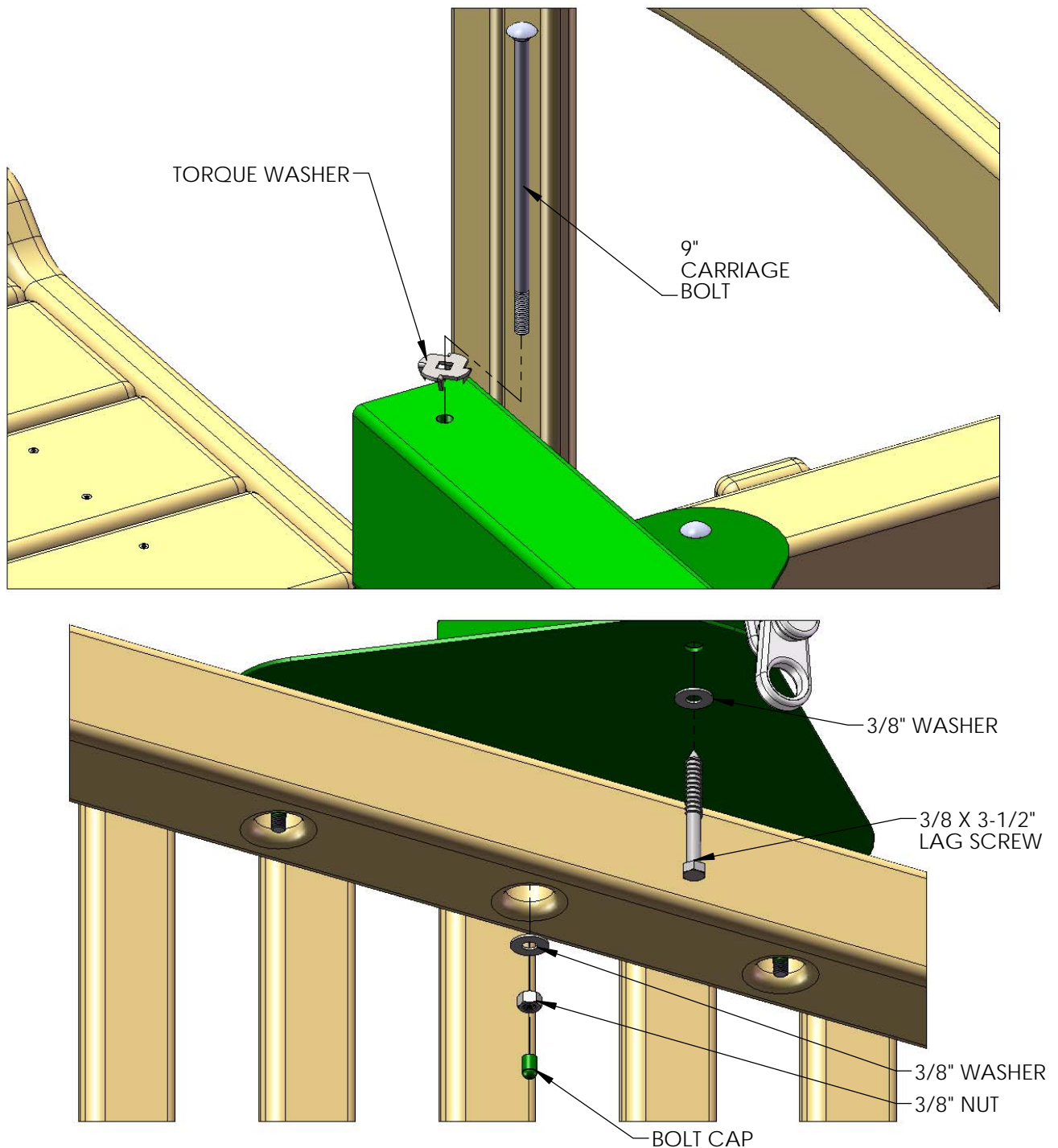

STEP 33: LEVEL SWING BEAM

1: PLACE A LEVEL ON TOP OF THE SWING BEAM AND ADJUST THE BEAM LEGS IN OR OUT AS NEEDED TO MAKE THE SWING BEAM LEVEL.



IMPORTANT NOTE:
THE LEGS ARE DESIGNED TO ACCOMODATE SWING BEAMS ON UNEVEN GROUND (DOWN SLOPE). THEY ARE LONGER THAN REQUIRED. IF YOUR GROUND IS RELATIVELY LEVEL, YOU MAY NEED TO EITHER
A) DIG IN BOTH LEGS WHERE THEY MEET THE GROUND, OR
B) BEND THE LEGS OUT SLIGHTLY TO MATCH YOUR GRADE.

STEP 34: SWING LEG CROSS-MEMBER

- 1: POSITION THE 2 X 4 X 58" SWING LEG CROSS-MEMBER AGAINST THE SWING BEAM LEGS.
- 2: LEVEL CROSS-MEMBER AND MARK THE LOCATION OF THE SECURING HOLES INSIDE THE CROSS-MEMBER HOLES.
- 3: USE 3/8 X 3-1/2" LAG SCREWS WITH 3/8" WASHERS TO SECURE THE CROSS-MEMBER TO THE SWING BEAM LEGS.

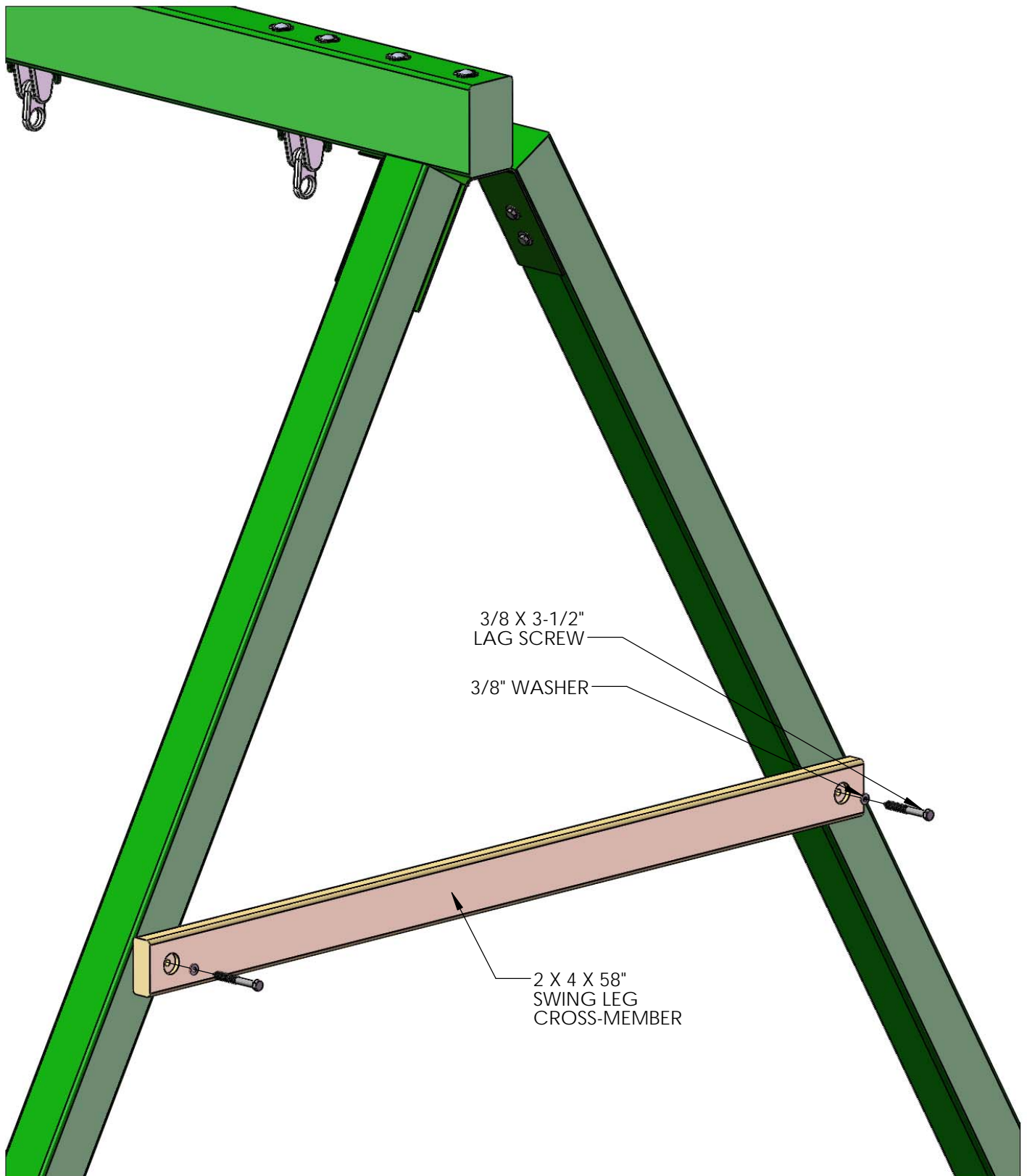

STEP 35: ROOF

1: PLACE THE TOP EDGE OF THE 1 X 5 X 53-1/2" ROOF STARTER BOARDS 54-1/2" AWAY FROM THE THE PEAK OF THE ROOF. THE HOLES IN THE ROOF STARTERS SHOULD BE CENTERED ON THE ROOF SUPPORTS. THE ROOF STARTER SHOULD OVERLAP THE SIDES OF THE ROOF SUPPORTS EQUALLY. THE BEVELED SIDE OF THE ROOF STARTER SHOULD LIE ON TOP OF THE ROOF SUPPORTS.

2: FASTEN THE ROOF STARTER BOARDS TO THE ROOF SUPPORTS WITH 1-1/2" WOOD SCREWS.

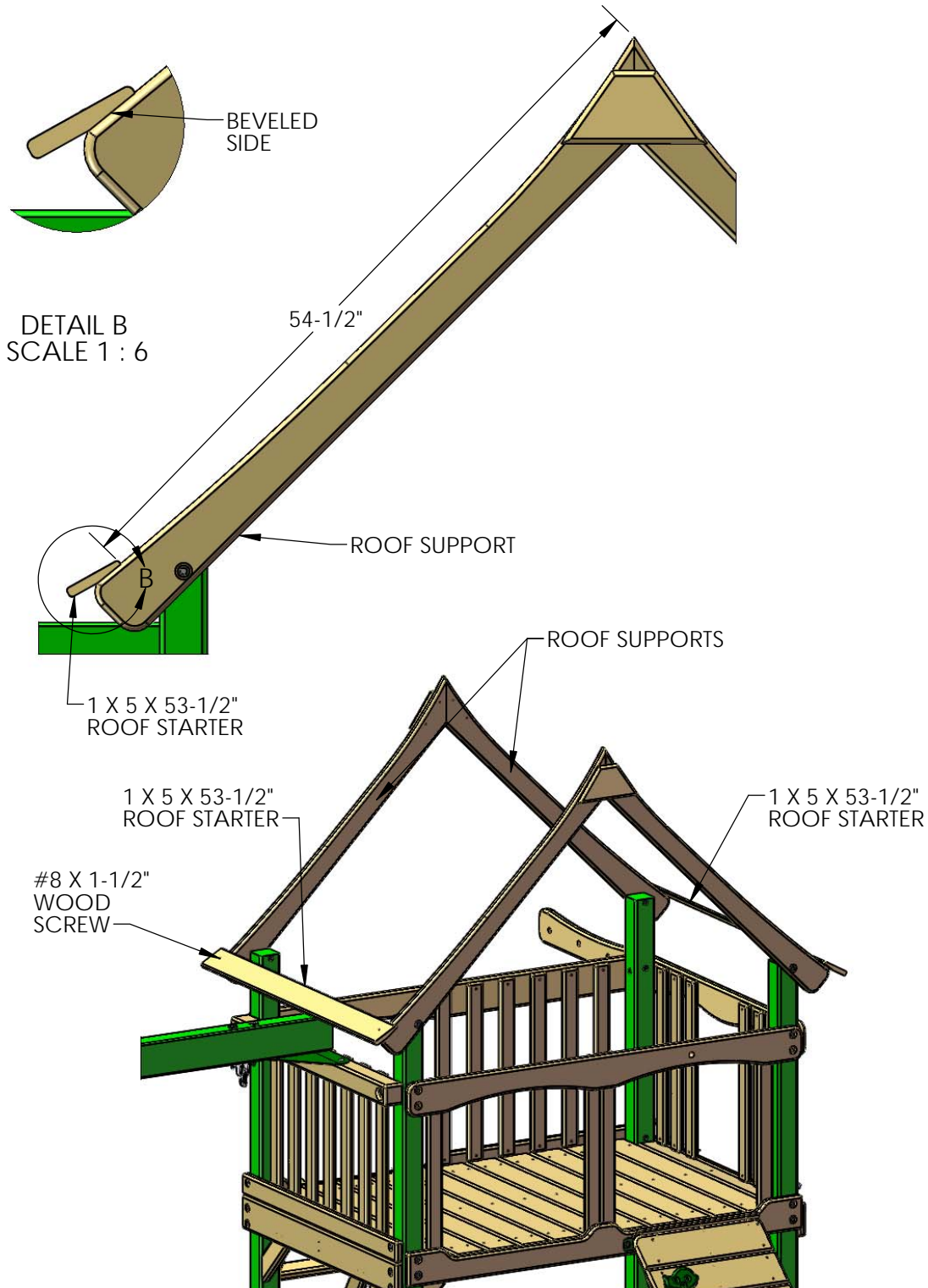

STEP 37: ROOF

1: LOCATE TWO SPACER BLOCKS AS SHOWN BELOW. VERIFY THAT THE SPACER BLOCKS HAVE THE CORRECT 3-3/4" DIMENSION SHOWN.

2: YOU WILL NEED SOME CLAMPS FOR THIS STEP. WE USE HAND OPERATED 2-1/2" SPRING CLAMPS. YOU CAN PURCHASE THIS TYPE OF CLAMP FROM YOUR LOCAL HOME CENTER.

3: PLACE A SPACER BLOCK ON TOP OF THE ROOF BOARD YOU INSTALLED IN STEP 36. YOU WILL NEED A SPACER BLOCK ON EACH END OF THE ROOF BOARD. MAKE SURE THE SPACER BLOCK IS FLUSH TO THE FRONT EDGE OF THE ROOF BOARD THAT IS ALREADY INSTALLED. NOW CLAMP THE SPACER BLOCK TO THE ROOF BOARD THAT IS ALREADY INSTALLED. REPEAT THIS PROCESS FOR THE SPACER BLOCK ON THE OTHER SIDE.

4: PLACE A 1 X 5 X 53-1/2" ROOF BOARD AGAINST THE SPACER BLOCK. NOW ATTACH THE ROOF BOARD TO THE ROOF SUPPORTS WITH #8 X 2" WOOD SCREWS.

5: REPEAT SUBSTEPS 3 AND 4 FOR THE REMAINING ROOF BOARDS UNTIL YOU GET ALMOST ALL THE WAY TO THE PEAK. NOTE, AT SOME POINT YOU WILL NEED A LADDER TO SECURE THE ROOF BOARDS NEAR THE PEAK.

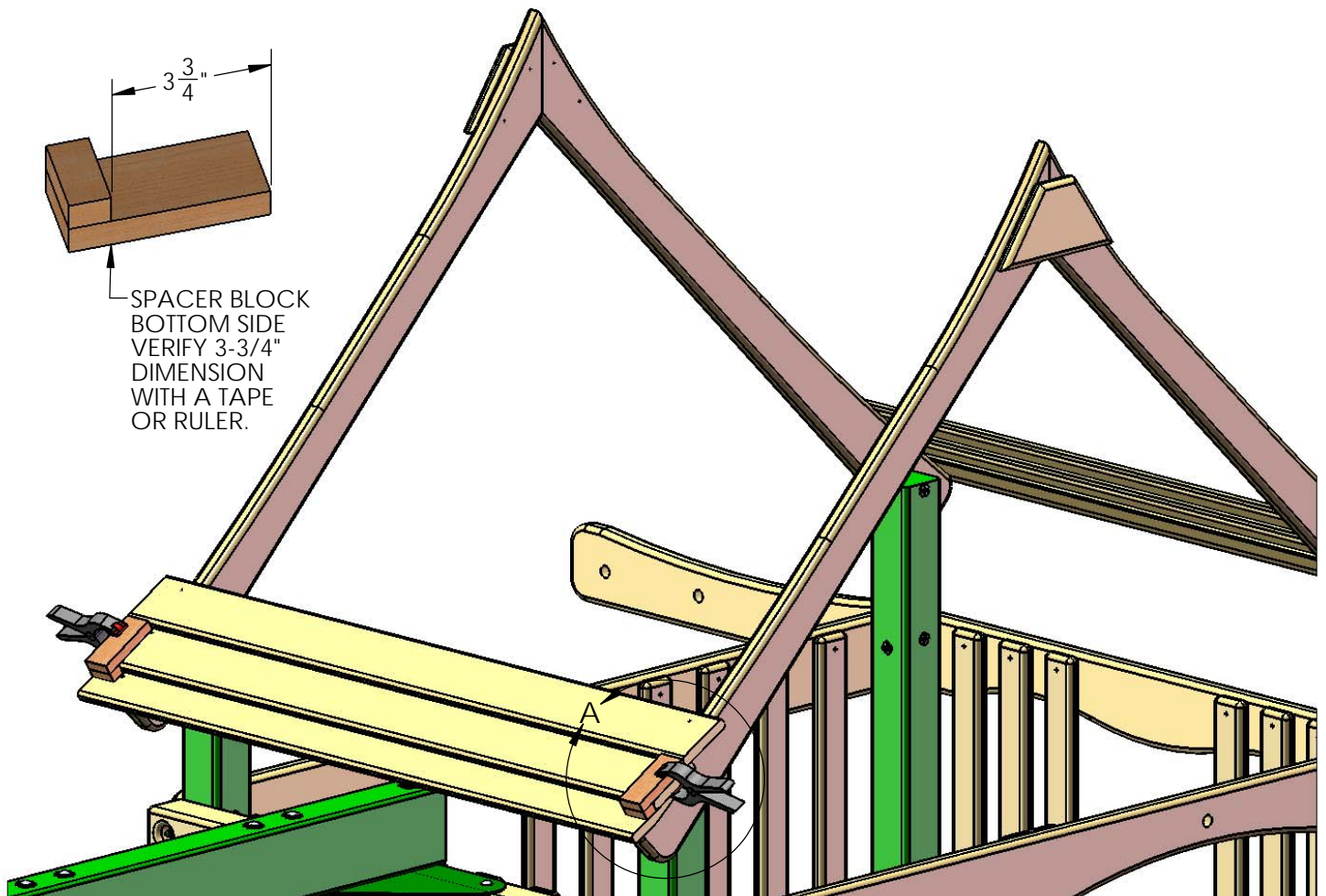

DETAIL A
SCALE 1 : 6

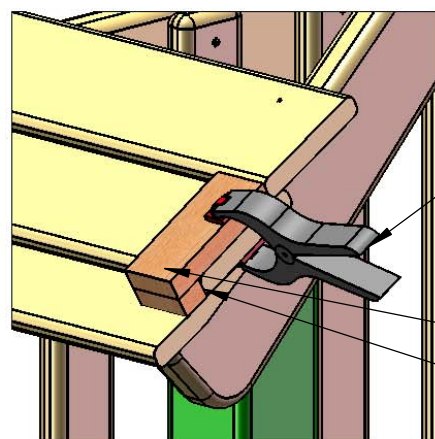

HAND OPERATED
2-1/2" SPRING CLAMP

SPACER BLOCK

SPACER BLOCK IS FLUSH HERE
AGAINST FRONT EDGE OF BOARD
INSTALLED IN STEP 36.

STEP 38: ROOF PEAK

- 1: LOCATE THE 5 X 5 X 53-1/2" ROOF PEAK ASSEMBLY.
- 2: PLACE THE ROOF PEAK ON TOP OF THE LAST ROOF BOARDS.
- 3: USE A 1/8" DRILL BIT TO PREDRILL HOLES IN THE ROOF BOARDS USING THE ROOF PEAK HOLES AS A GUIDE.
- 4: ATTACH THE ROOF PEAK TO THE ROOF BOARDS WITH #8 X 2-1/2" WOOD SCREWS.

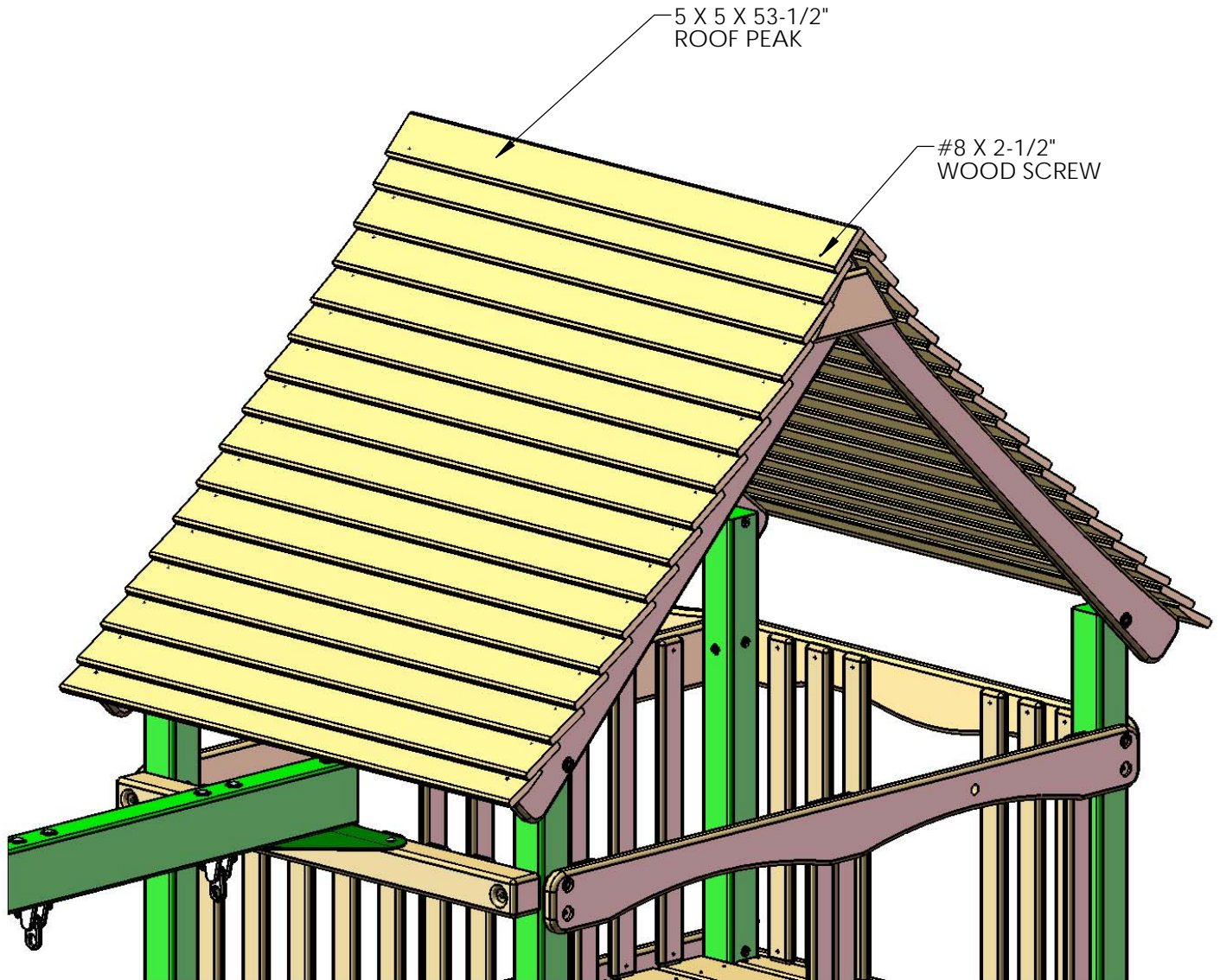

STEP 39: SUNBURST

1: LOCATE ONE 5/4 X 3 X 17-1/2" LARGE RAY, TWO 5/4 X 3 X 11" SMALL RAYS AND ONE 5/4 X 4 X 42" RAY SUPPORT.

2: LAY ALL THE PARTS OUT ON A FLAT SURFACE AS SHOWN BELOW.

3: CENTER THE LARGE RAY WITH THE CENTER OF THE RAY SUPPORT. PAY ATTENTION TO THE HOLE LOCATIONS IN THIS PART SO YOU DO NOT PLACE IT UPSIDE DOWN. ATTACH THE LARGE RAY TO THE RAY SUPPORT WITH TWO #8 X 2-1/2" WOOD SCREWS.

4: PLACE A SMALL RAY ON EITHER SIDE OF THE LARGE RAY AS SHOWN. ATTACH EACH SMALL RAY TO THE RAY SUPPORT WITH ONE #8 X 2-1/2" WOOD SCREW.

5: REPEAT SUBSTEPS 1 THROUGH 4 AND ASSEMBLE ONE MORE SUNBURST.

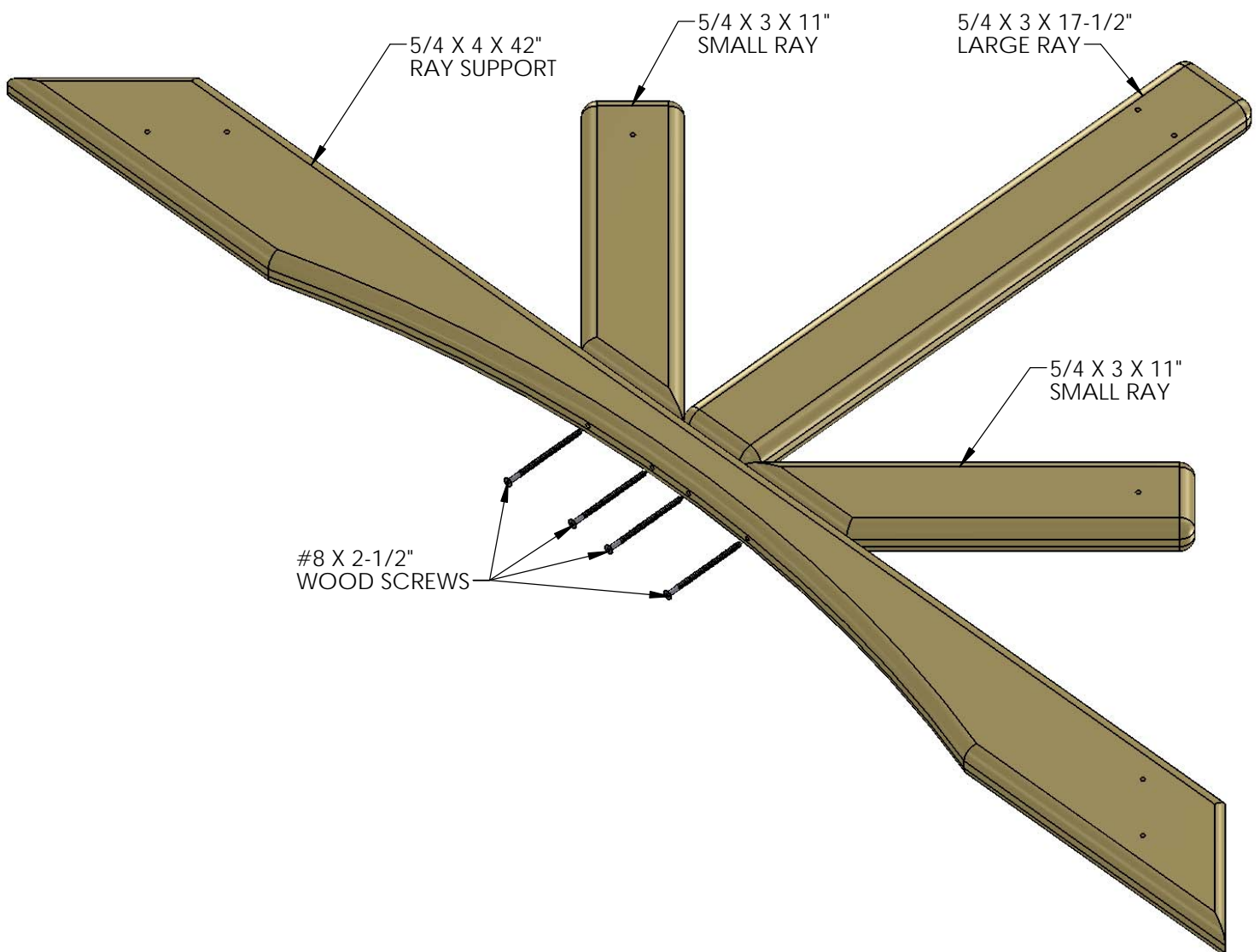

STEP 40: SUNBURST INSTALLATION

- 1: EACH SUNBURST ASSEMBLY WILL BE LOCATED ON THE INSIDE OF THE ROOF SUPPORTS.
- 2: LEVEL THE SUNBURST SUPPORT.
- 3: FASTEN THE EACH SUNBURST ASSEMBLY TO THE ROOF SUPPORTS WITH #8 X 2" WOOD SCREWS.

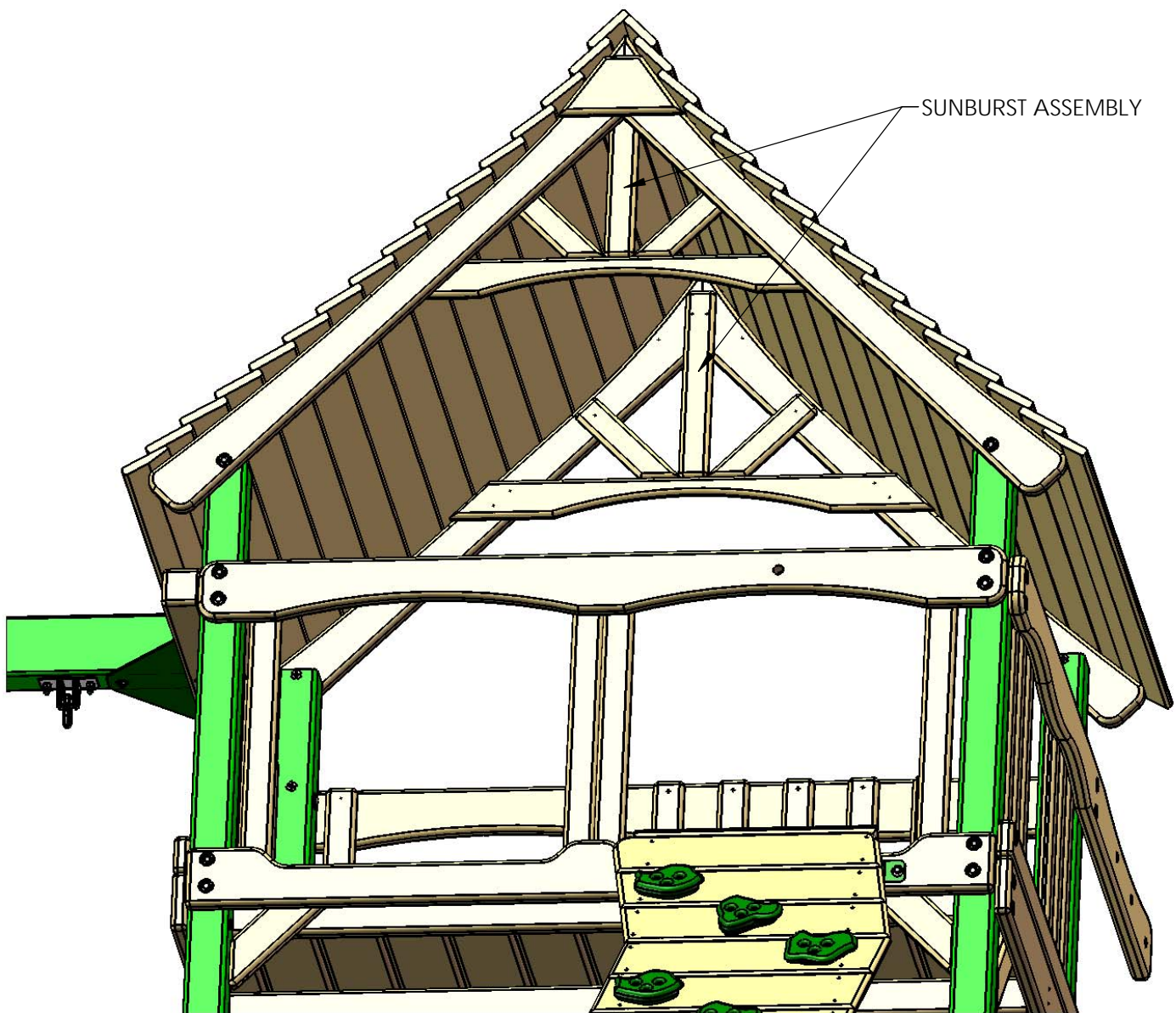

STEP 41: PICNIC TABLE

1: LOCATE TWO 2 X 4 X 14-3/4" PT TOP SUPPORTS, TWO 2 X 4 X 27-1/2" PT SEAT SUPPORTS, TWO 2 X 4 X 32-1/2" PT LEGS AND TWO 5/4 X 3 X 13-1/4" PICNIC TABLE SLATS.

2: FOR THE LEFT SIDE ASSEMBLY, PLACE A 2 X 4 X 14-3/4" PT TOP SUPPORT AND A 2 X 4 X 27-1/2" PT SEAT SUPPORT PARALLEL TO ONE ANOTHER. PLACE A 2 X 4 X 32-1/2" PT LEG ON TOP AT THE 7-1/2" DIMENSION. THE TOP OF THE PT LEG SHOULD BE FLUSH TO THE TOP OF THE PT TOP SUPPORT. ATTACH THE PT LEG TO THE SUPPORTS WITH #8 X 2-1/2" WOOD SCREWS.

3: FOR THE RIGHT SIDE ASSEMBLY, PLACE A 2 X 4 X 14-3/4" PT TOP SUPPORT AND A 2 X 4 X 27-1/2" PT SEAT SUPPORT PARALLEL TO ONE ANOTHER. PLACE A 2 X 4 X 32-1/2" PT LEG ON TOP AT THE 7-1/2" DIMENSION. THE TOP OF THE PT LEG SHOULD BE FLUSH TO THE TOP OF THE PT TOP SUPPORT. ATTACH THE PT LEG TO THE SUPPORTS WITH #8 X 2-1/2" WOOD SCREWS.

4: PLACE THE PICNIC TABLE SLAT NEXT TO THE PICNIC TABLE LEG FOR EACH ASSEMBLY BELOW. LEAVE A 3/16" GAP BETWEEN THE TOP OF THE SLAT AND THE LEG. USE THE 6-15/16" DIMENSION TO LOCATE THE BOTTOM END OF THE SLAT. FASTEN THE PICNIC TABLE SLAT TO THE SUPPORTS WITH TWO #8 X 2" WOOD SCREWS.

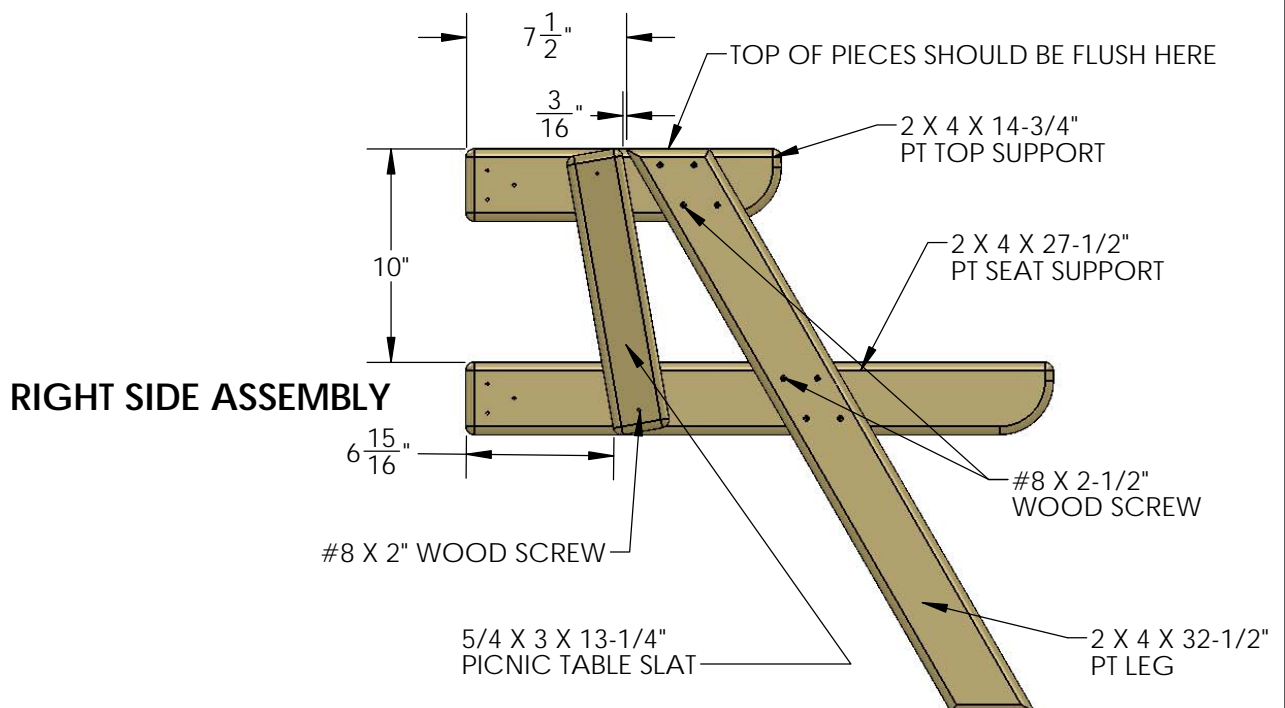
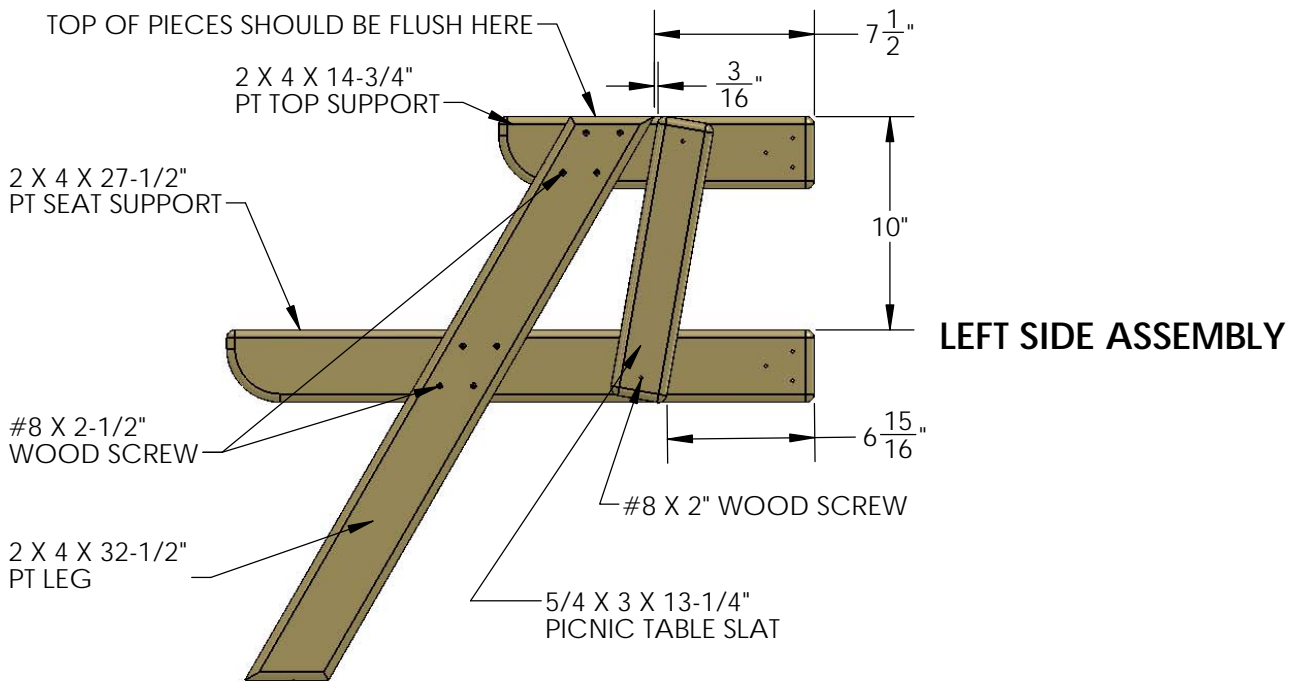

STEP 42: PICNIC TABLE

1: MEASURE UP 26-3/8" FROM THE BOTTOM OF THE CORNER POSTS ON THE RIGHT SIDE OF THE PLAYSET. MAKE MARKS ON THE INSIDE OF THE CORNER POSTS WITH A PEN OR PENCIL AT 26-3/8"

2: PLACE THE TOP OF THE RIGHT SIDE ASSEMBLY FLUSH TO THE MARK ON THE RIGHT FRONT CORNER POST. ATTACH THE RIGHT SIDE ASSEMBLY TO THE INSIDE OF THE CORNER POST WITH #8 X 3" WOOD SCREWS.

3: PLACE THE TOP OF THE LEFT SIDE ASSEMBLY FLUSH TO THE MARK ON THE RIGHT REAR CORNER POST. ATTACH THE LEFT SIDE ASSEMBLY TO THE INSIDE OF THE CORNER POST WITH #8 X 3" WOOD SCREWS.

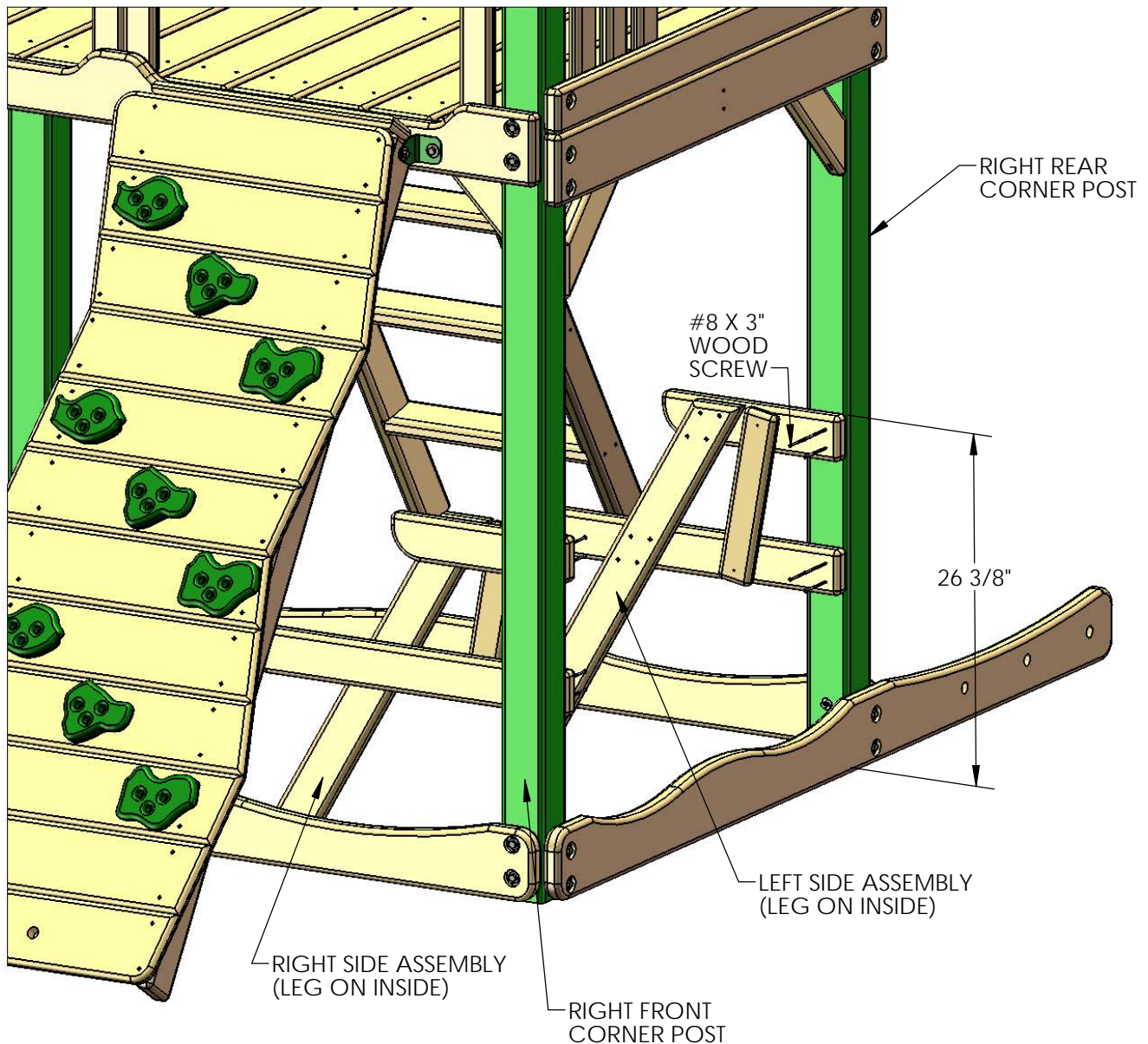

STEP 43: PICNIC TABLE

- 1: LOCATE FOUR 5/4 X 6 X 43" PT TOP AND SEAT BOARDS.
- 2: CENTER THE HOLES IN THE BOARDS OVER THE TOP OR SEAT SUPPORTS.
- 3: FASTEN THE PT TOP AND SEAT BOARDS TO THE TOP OR SEAT SUPPORTS WITH #8 X 2-1/2" WOOD SCREWS.

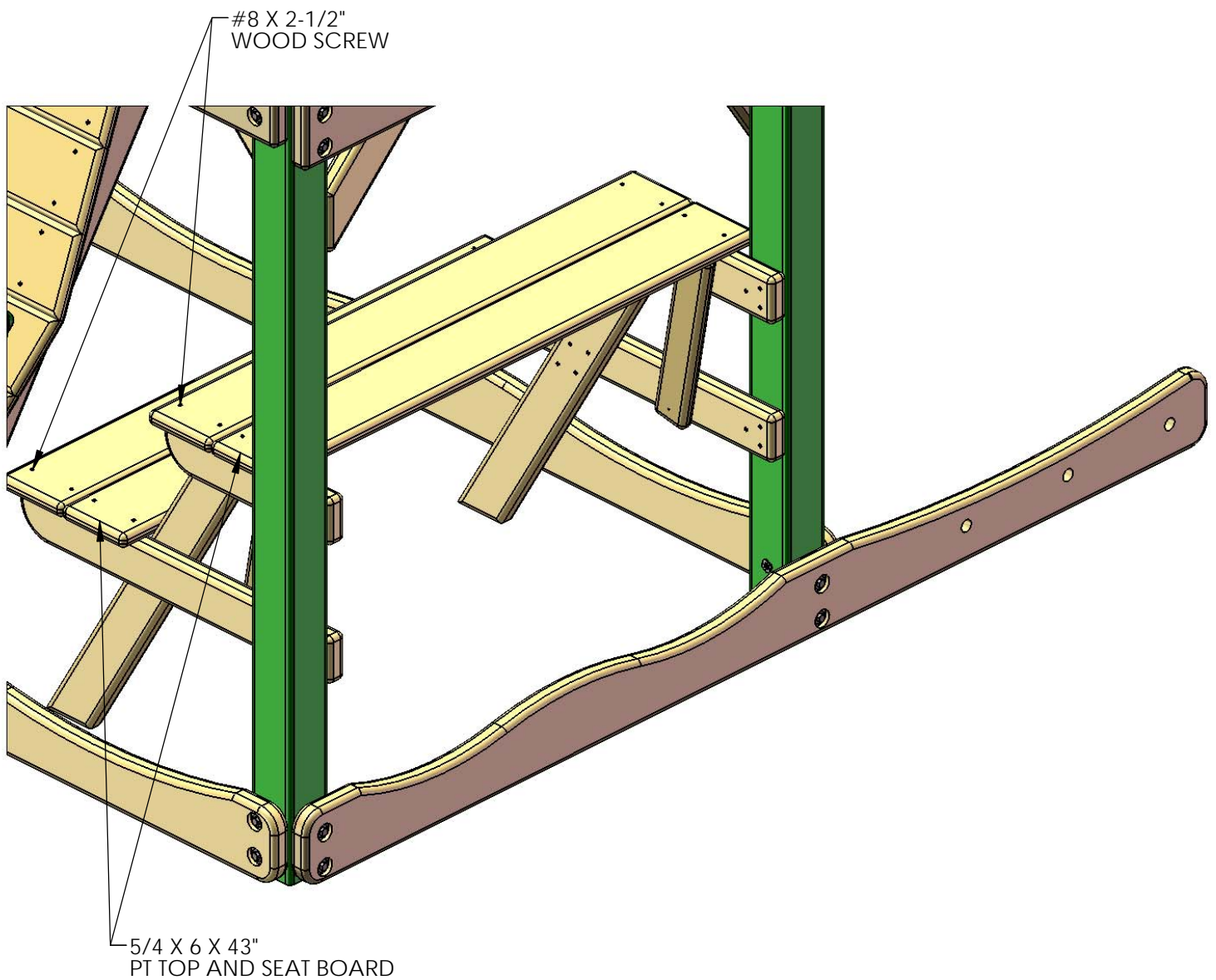

STEP 44: ROPE LADDER

1: FIND THREE ROPE LADDER ROPES. MAKE A KNOT IN THE END OF EACH ROPE AND THREAD THE FREE END THROUGH THE BACK SIDE OF THE ROPE LADDER SUPPORT. PULL EACH ROPE TAUGHT.

2: MEASURE DOWN FROM THE BOTTOM OF THE ROPE LADDER SUPPORT 6 INCHES AND TIE A KNOT. THE BOTTOM OF THE KNOT SHOULD BE 6 INCHES BELOW THE ROPE LADDER SUPPORT. SLIDE EACH ROPE THROUGH THE HOLES IN ONE ROPE LADDER RUNG. SLIDE THE RUNG UP AGAINST THE BOTTOM OF THE KNOTS.

3: TIE THREE KNOTS BELOW THE ROPE LADDER RUNG.

4: MEASURE DOWN FROM THE BOTTOM OF THE ROPE LADDER RUNG 10-5/8 INCHES AND MAKE A MARK ON THE ROPE WITH A PIECE OF TAPE OR A MARKER. THREAD ANOTHER ROPE LADDER RUNG ONTO THE ROPES.

5: WITH THE TOP OF THE RUNG EVEN WITH THE 10-5/8 INCH MARK TIE THREE KNOTS BELOW THE SECOND ROPE LADDER RUNG.

6: REPEAT SUBSTEPS 4-5 FOR THE REMAINING ROPE LADDER RUNGS.

7: THREAD THE BOTTOM END OF EACH ROPE THROUGH THE HOLES IN THE ROPE LADDER RUNNER AND TIE THEM OFF. GRAB EACH ROPE AND ATTEMPT TO WRAP IT AROUND YOUR HAND. IF THE ROPE WRAPS AROUND YOUR HAND IT IS TOO LOOSE. IF THE ROPE IS TOO LOOSE UNTIE THE KNOT BEHIND THE ROPE LADDER RUNNER AND RETIE IT UNTIL YOU CAN NO LONGER WRAP THE ROPE AROUND YOUR HAND.

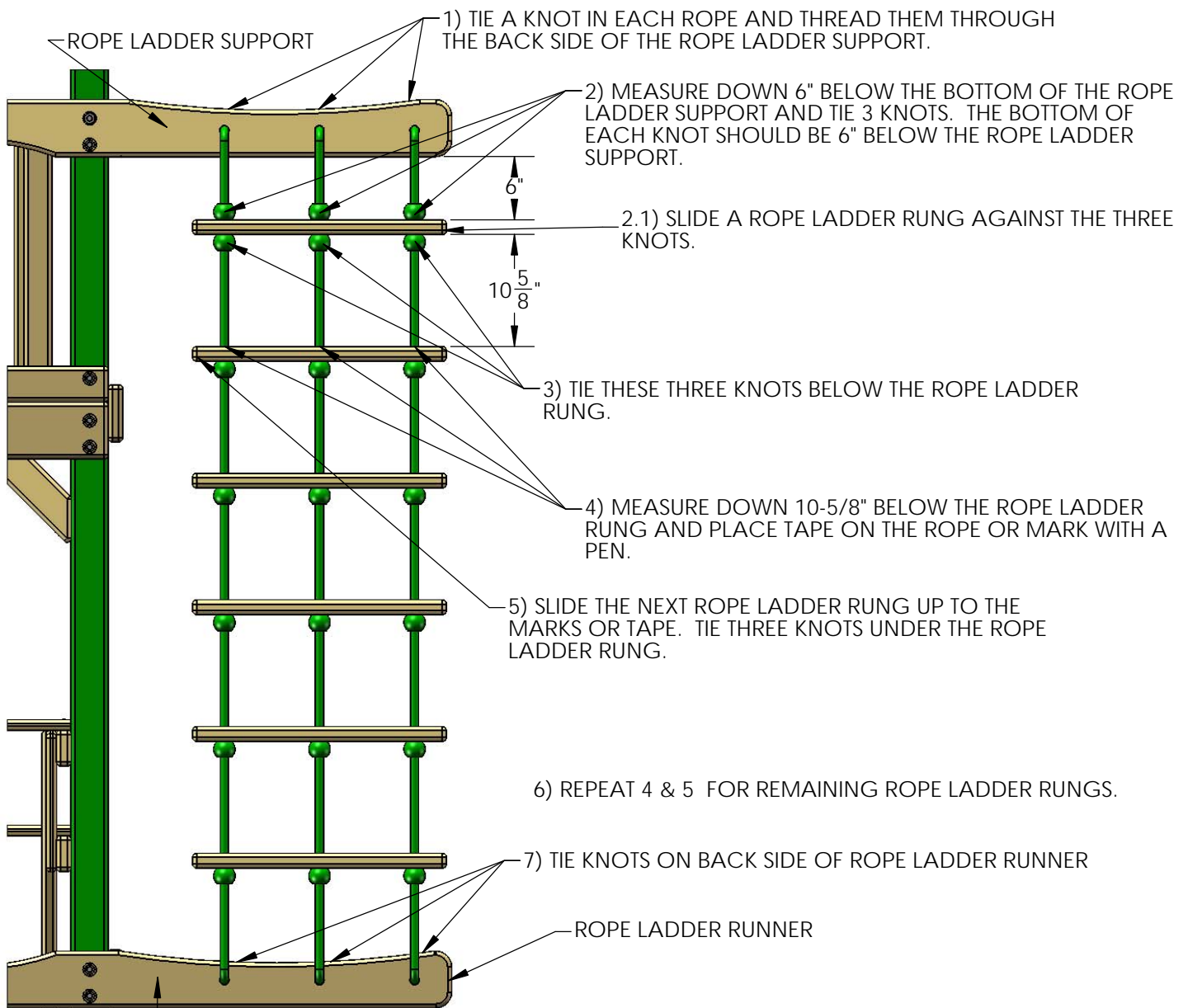

THIS IS THE VIEW AS IF YOU WERE STANDING AT THE RIGHT SIDE OF THE FORT LOOKING AT IT.

STEP 45: MOUNTING THE SLIDE

1: PLACE THE SLIDE IN THE OPENING AT THE FRONT OF THE PLAY SET NEXT TO THE ROCK WALL.

2: THE FLARED END OF THE SLIDE WILL REST ON TOP OF THE BOTTOM PANEL BOARD. THE FLAT AREA OF THE SLIDE WITH THE FOUR INDENTATIONS WILL LIE ON TOP OF THE DECK BOARDS.

3: ALIGN THE HOLES IN THE SLIDE OVER THE DECK BOARDS AVOIDING GAPS. PREDRILL 1/8" PILOT HOLES THROUGH THE CENTER OF THE INDENTATIONS IN THE SLIDE INTO THE DECK BOARDS. ATTACH THE SLIDE TO THE DECK BOARDS WITH FOUR 1-1/4" PAN HEAD SCREWS.
**** DO NOT OVER TIGHTEN****



FLAT AREA LIES OVER DECK BOARDS

#14 X 1-1/4" PAN HEAD SCREW
**** DO NOT OVER TIGHTEN ****

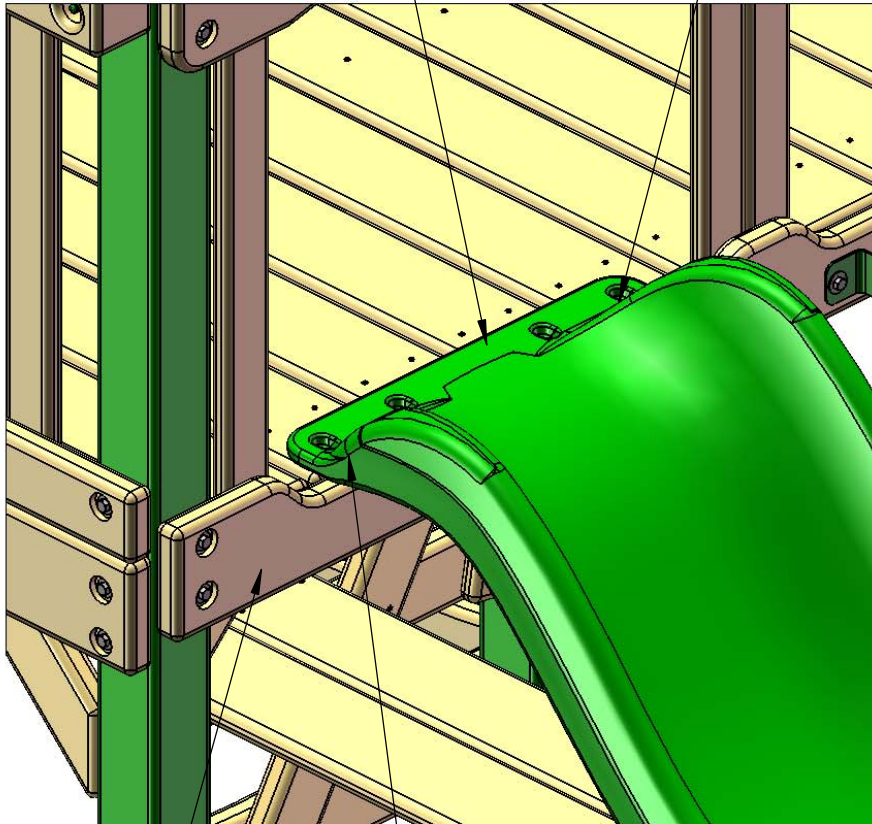

BOTTOM
PANEL
BOARD

FLARED END RESTS OVER BOTTOM PANEL BOARD.

STEP 46: MOUNTING THE TELESCOPE

1: WITH THE 1-1/4" WOOD SCREWS PROVIDED IN THE TELESCOPE BAG, FASTEN ONE OF THE SQUARE TELESCOPE BRACKETS NEXT TO THE PANEL SLAT ON THE INSIDE OF THE FORT.

2: PLACE THE TELESCOPE STAND AND TELESCOPE INTO THE SLOT OF THE TELESCOPE BRACKET.

3: FASTEN THE REMAINING SQUARE TELESCOPE BRACKET TO THE OPPOSITE SIDE THAT THE FIRST TELESCOPE BRACKET WAS INSTALLED ON WITH 1-1/4" WOOD SCREWS.

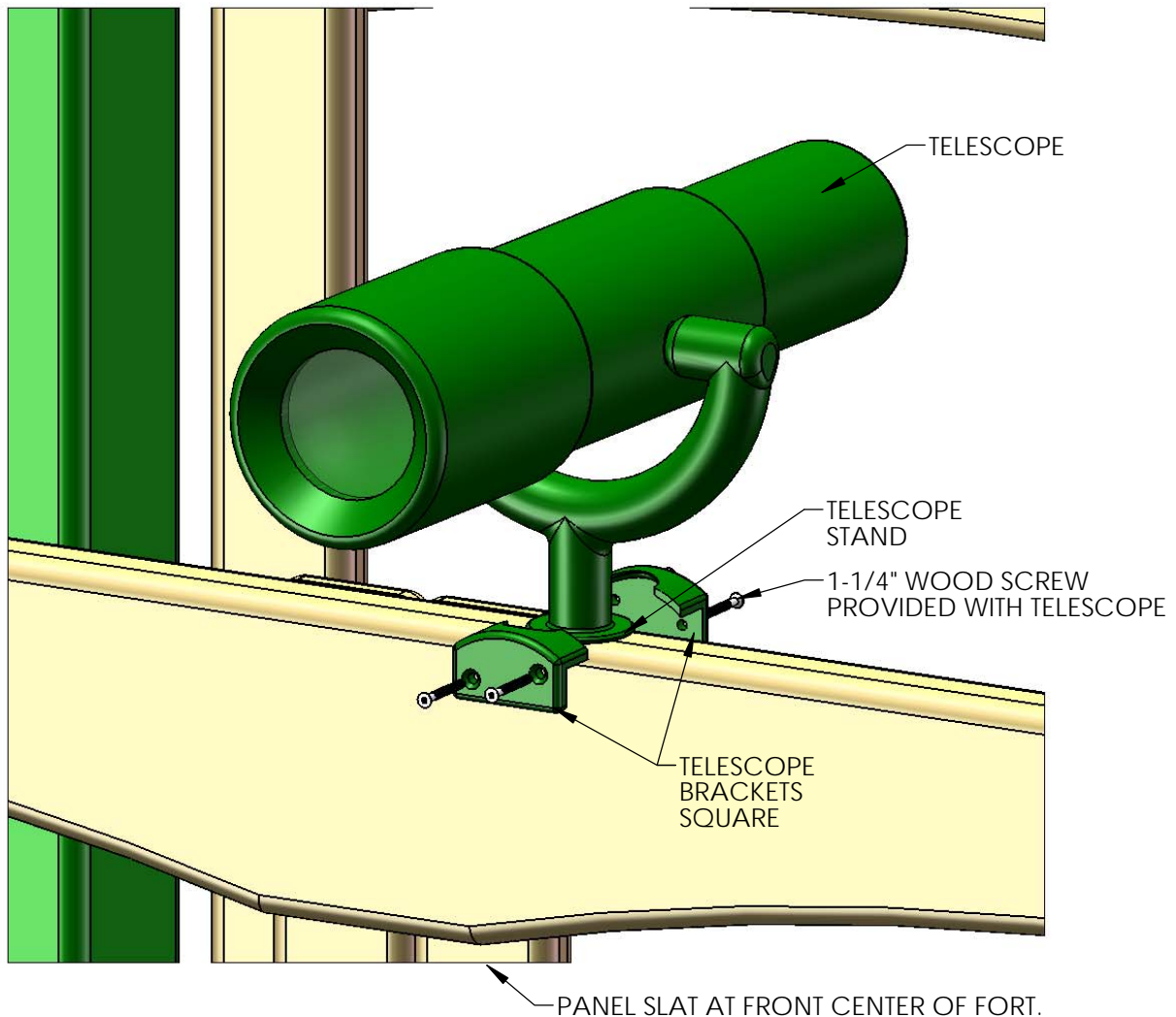

STEP 47: INSTALLING ROCK WALL ROPE

- 1: TIE A KNOT IN ONE END OF THE 10 FOOT ROCK WALL ROPE.
- 2: THREAD THE ROPE THROUGH THE BACK SIDE OF THE FRONT TOP PANEL BOARD.
- 3: YOU MAY TIE UP TO TWO KNOTS TO AID YOUR CHILD WHEN CLIMBING.
- 4: THREAD THE LOWER END OF THE ROCK WALL ROPE THROUGH THE HOLE IN THE FRONT SIDE OF THE ROCK WALL. TIE A SECURE KNOT ON THE BACK SIDE OF THE ROCK WALL.

TEST THE ROCK WALL ROPE BY ATTEMPTING TO WRAP IT AROUND YOUR HAND. IF THE ROPE WRAPS AROUND YOUR HAND IT IS TOO LOOSE. UNTIE ONE END OF THE ROPE AND RETIE IT UNTIL IT NO LONGER WRAPS AROUND YOUR HAND.

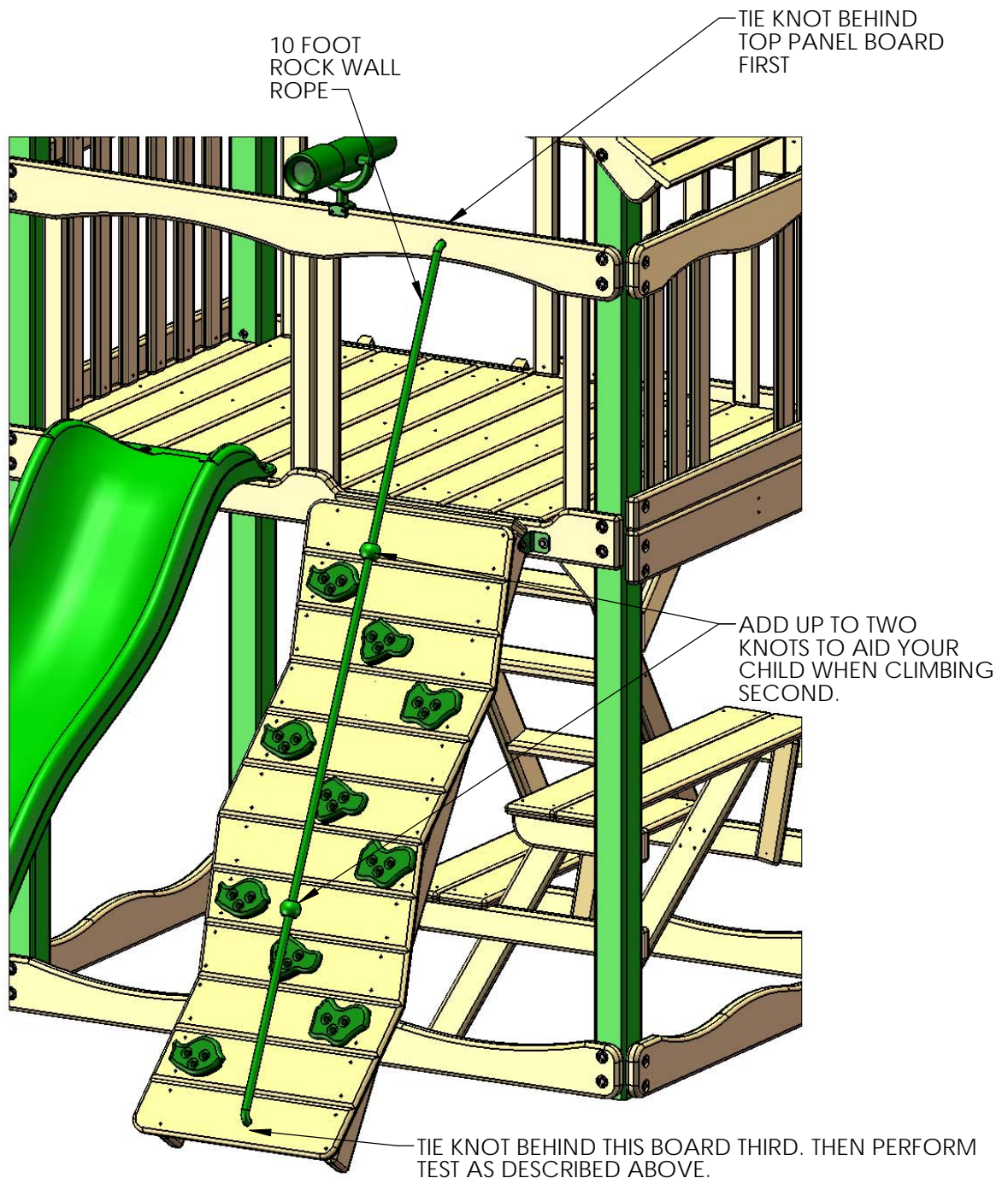

STEP 48: TIC TAC TOE ASSEMBLY

1: LOCATE THE TIC TAC TOE BOX.

2: FOLLOW THE INSTRUCTIONS IN THE BOX TO ASSEMBLE THE TIC TAC TOE OMITTING STEPS 6 AND 7.

3: LOCATE TWO 5/4 X 3 X 19" TIC TAC TOE MOUNTS.

4: USE THE SCREWS INCLUDED WITH THE TIC TAC TOE TO ATTACH THE GREEN BRACKETS TO THE TIC TAC TOE MOUNTS. EACH GREEN BRACKET SHOULD BE CENTERED OVER THE TIC TAC TOE MOUNT.

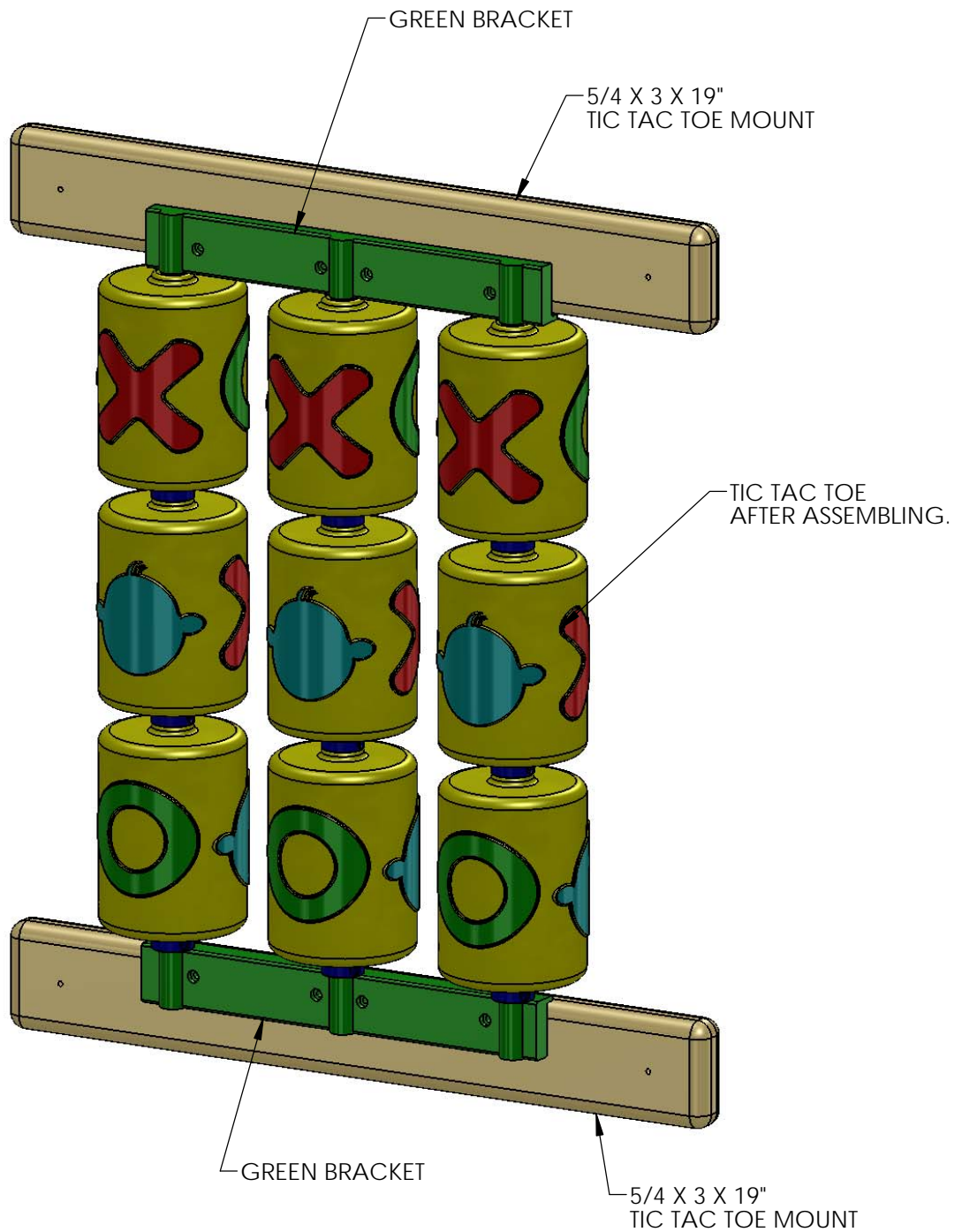

STEP 49: TIC TAC TOE INSTALLATION

1: PLACE THE TIC TAC TOE AGAINST THE PANEL SLATS AT THE RIGHT SIDE OF THE PLAY SET ON THE INSIDE. THE LOWER TIC TAC TOE MOUNT SHOULD BE APPROXIMATELY 4" OFF THE DECK.

2: ATTACH THE TIC TAC TOE MOUNTS TO THE PANEL SLATS WITH #8 X 1-3/4" WOOD SCREWS.

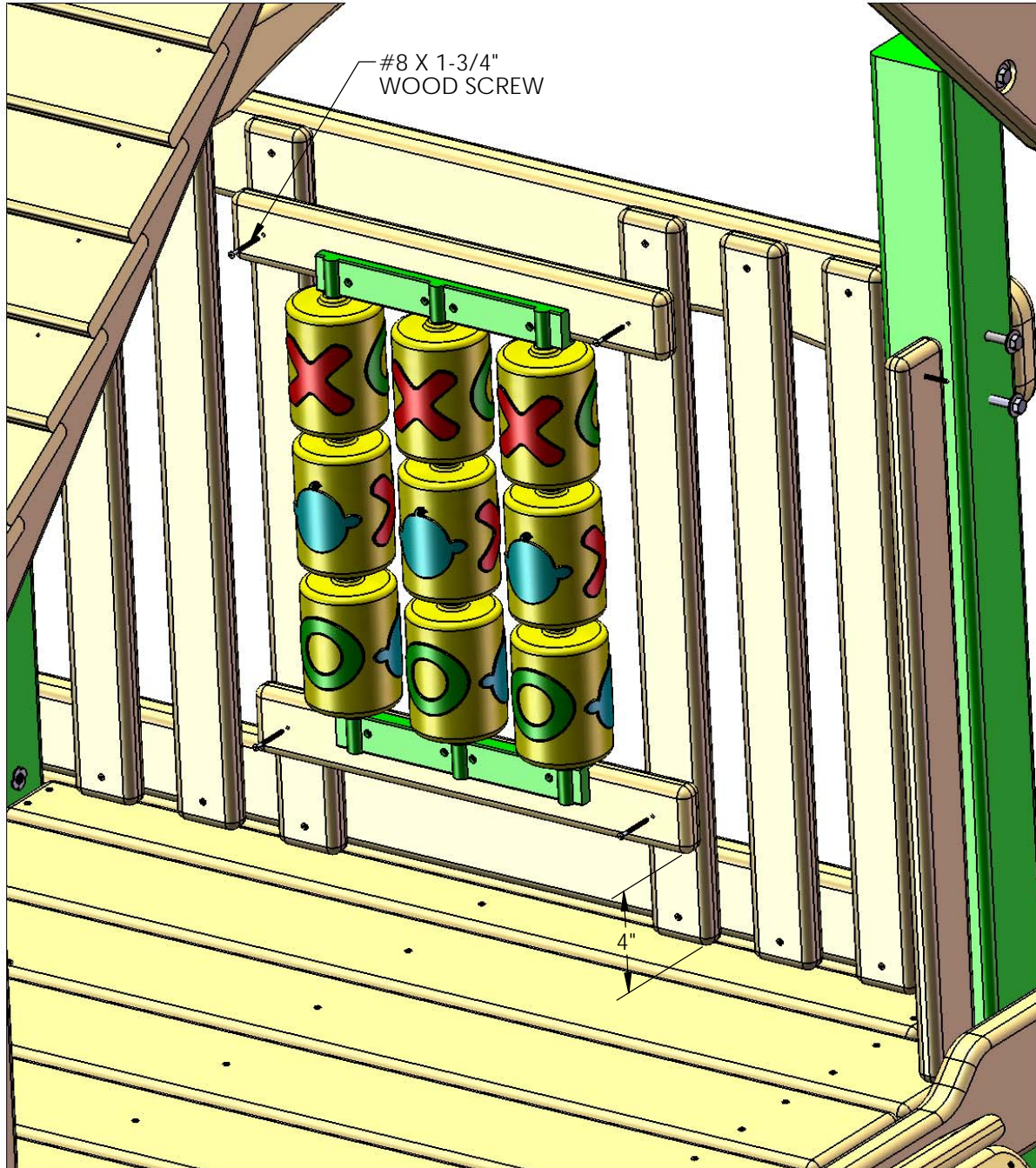

STEP 50: SAFETY HANDLES

- 1: LOCATE THE SAFETY HANDLE BAG.
- 2: ADJUST THE SAFETY HANDLES UP OR DOWN TO SUIT THE NEEDS OF YOUR CHILD.
- 3: ATTACH EACH SAFETY HANDLE TO THE PANEL SLATS WITH TWO PAN HEAD SCREWS AND TWO WASHERS PROVIDED WITH THE SAFETY HANDLES.

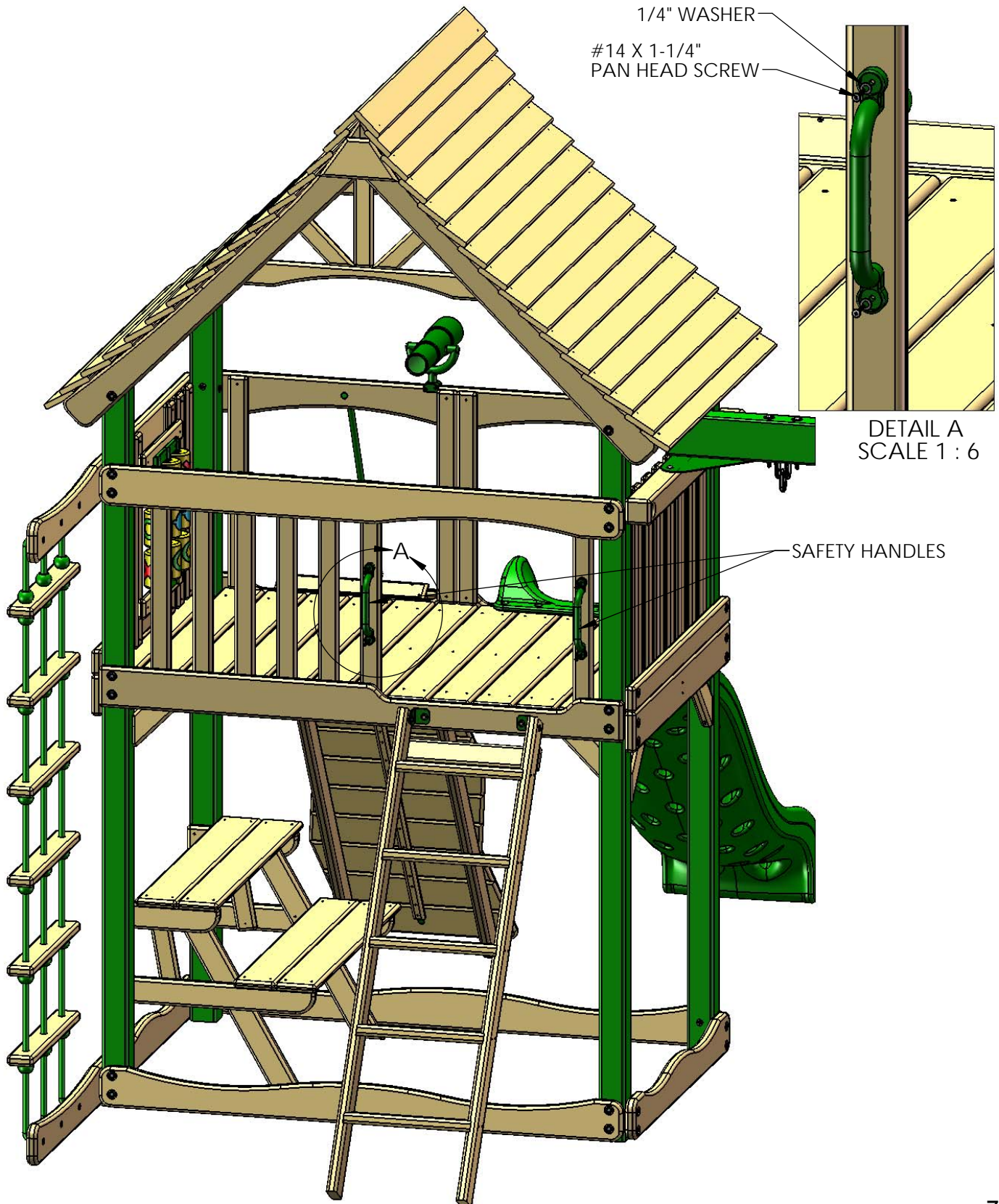

STEP 51: FLAG KIT

1: PLACE THE PLASTIC BASE OF EACH FLAG ONTO THE FRONT CORNER POSTS AS SHOWN.

2: ATTACH THE PLASTIC BASE TO THE CORNER POST WITH THE 1/2" PAN HEAD SCREWS PROVIDED WITH THE FLAGS.

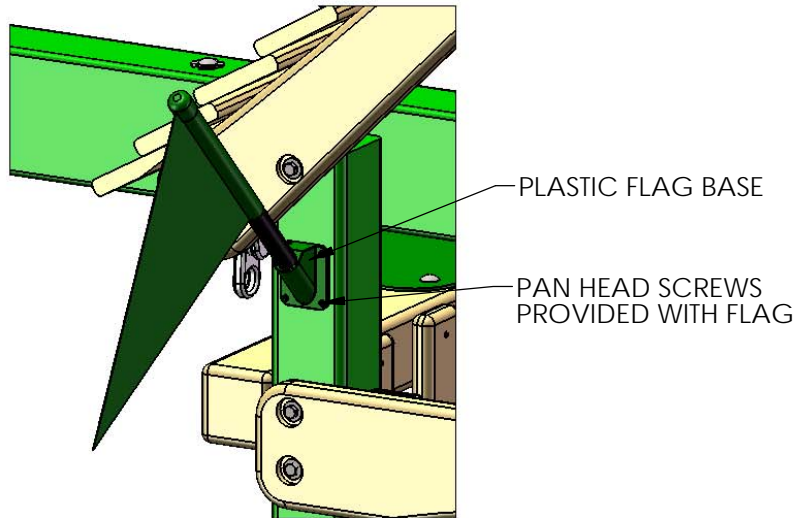

DETAIL A
SCALE 1 : 8

FLAGS

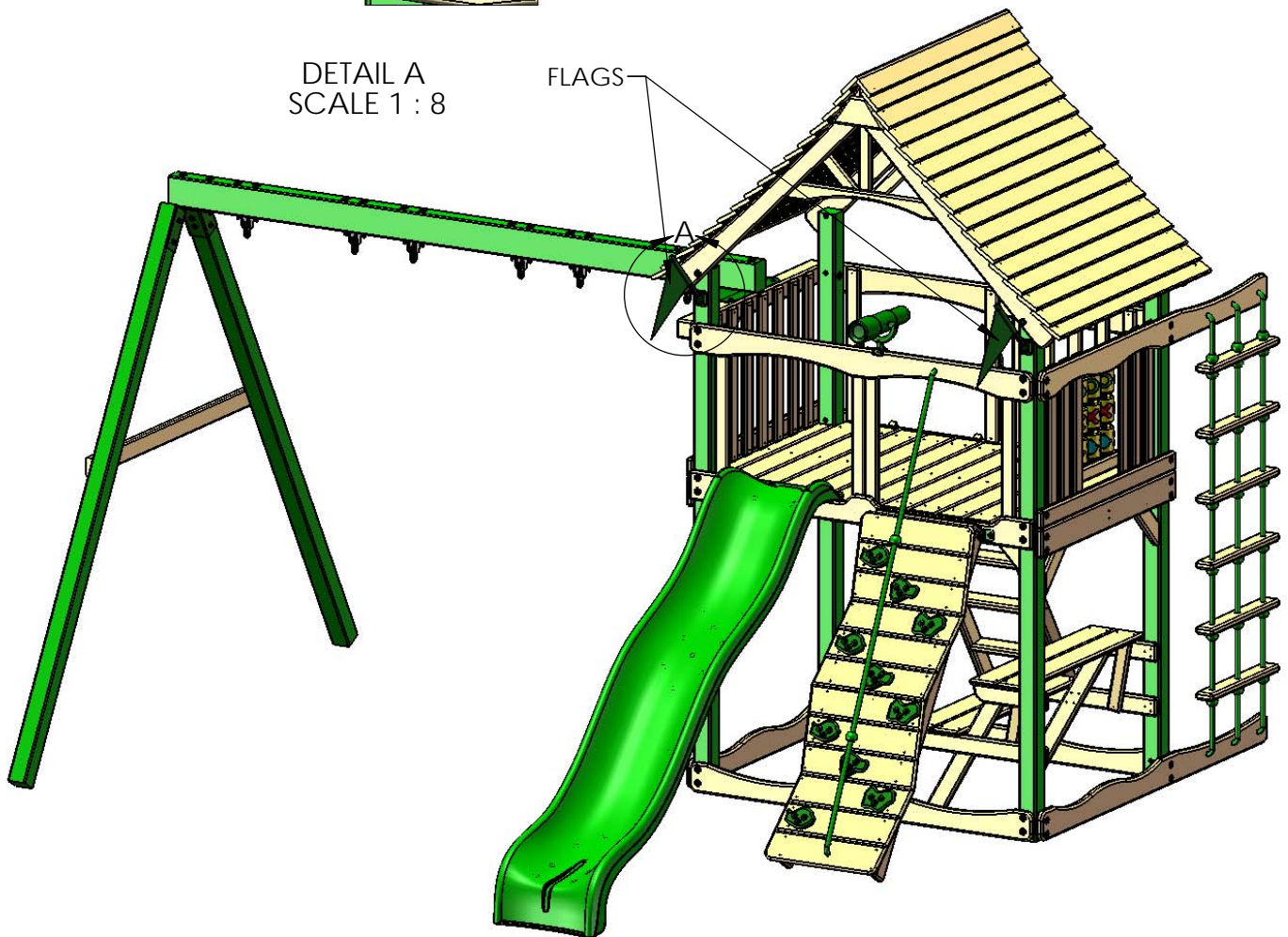

STEP 52: HANGING SWINGS

- 1: LOCATE THE SWING BELTS, TRAPEZE BAR AND SIX SPRING CLIPS.
- 2: SNAP A SPRING CLIP ONTO EACH IRON DUCTILE SWING HANGER.
- 3: HANG ONE CHAIN FROM EACH ACCESSORY ONTO EACH SPRING CLIP.
- 4: ADJUST SWINGS UP OR DOWN BY CLIPPING ONTO HIGHER OR LOWER CHAIN LINKS.

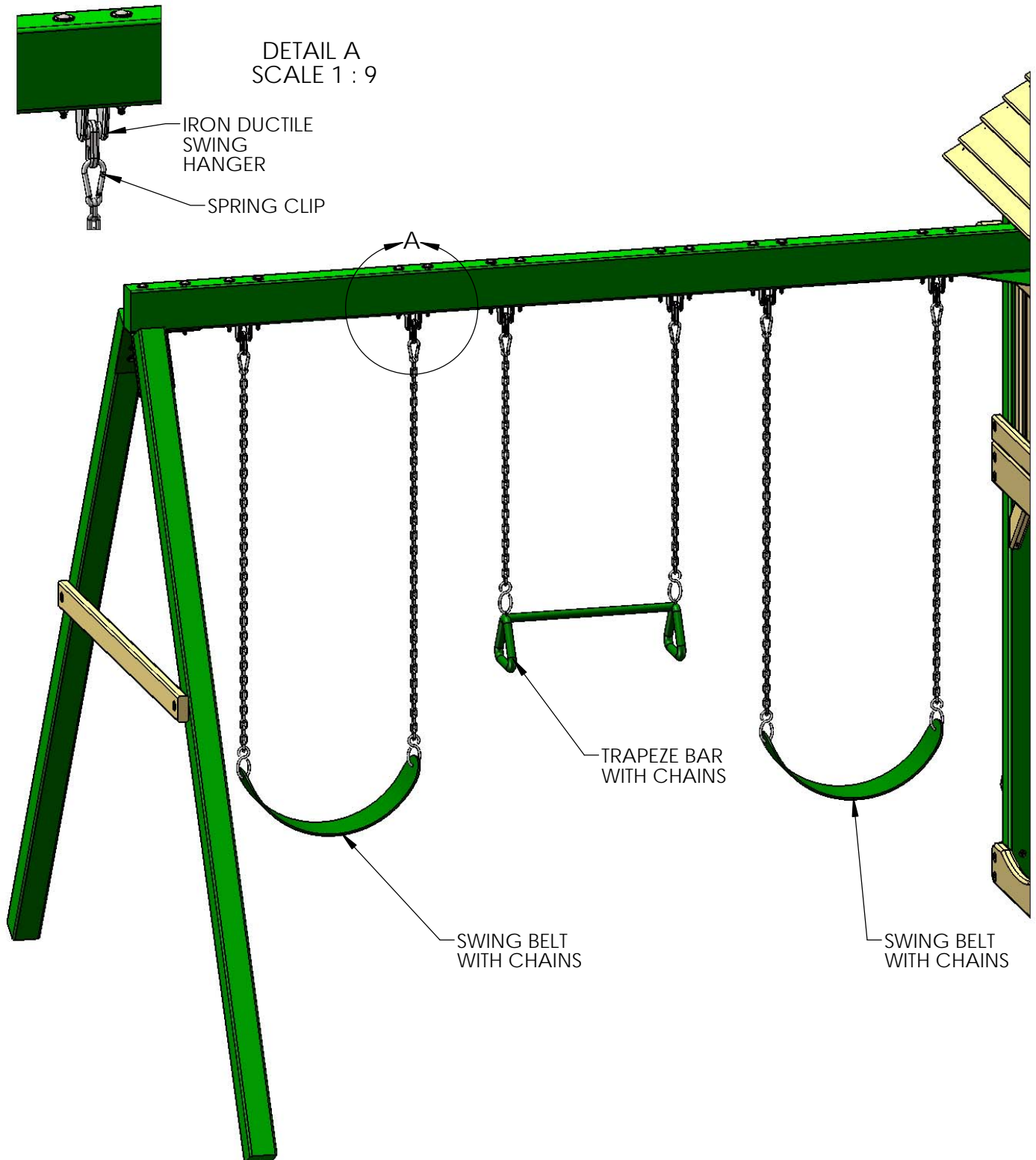

STEP 53: GROUND STAKES AND NAME PLATE

- 1: HAMMER IN THE GROUND STAKES AT AN ANGLE NEXT TO THE SWING LEGS.
- 2: FASTEN EACH GROUND STAKE TO THE SWING LEG WITH THE 2" SCREW PROVIDED WITH THE GROUND STAKE.
- 3: FASTEN THE NAME PLATE TO THE SWING BEAM AT THE CENTER WITH TWO #8 X 1-1/2" WOOD SCREWS

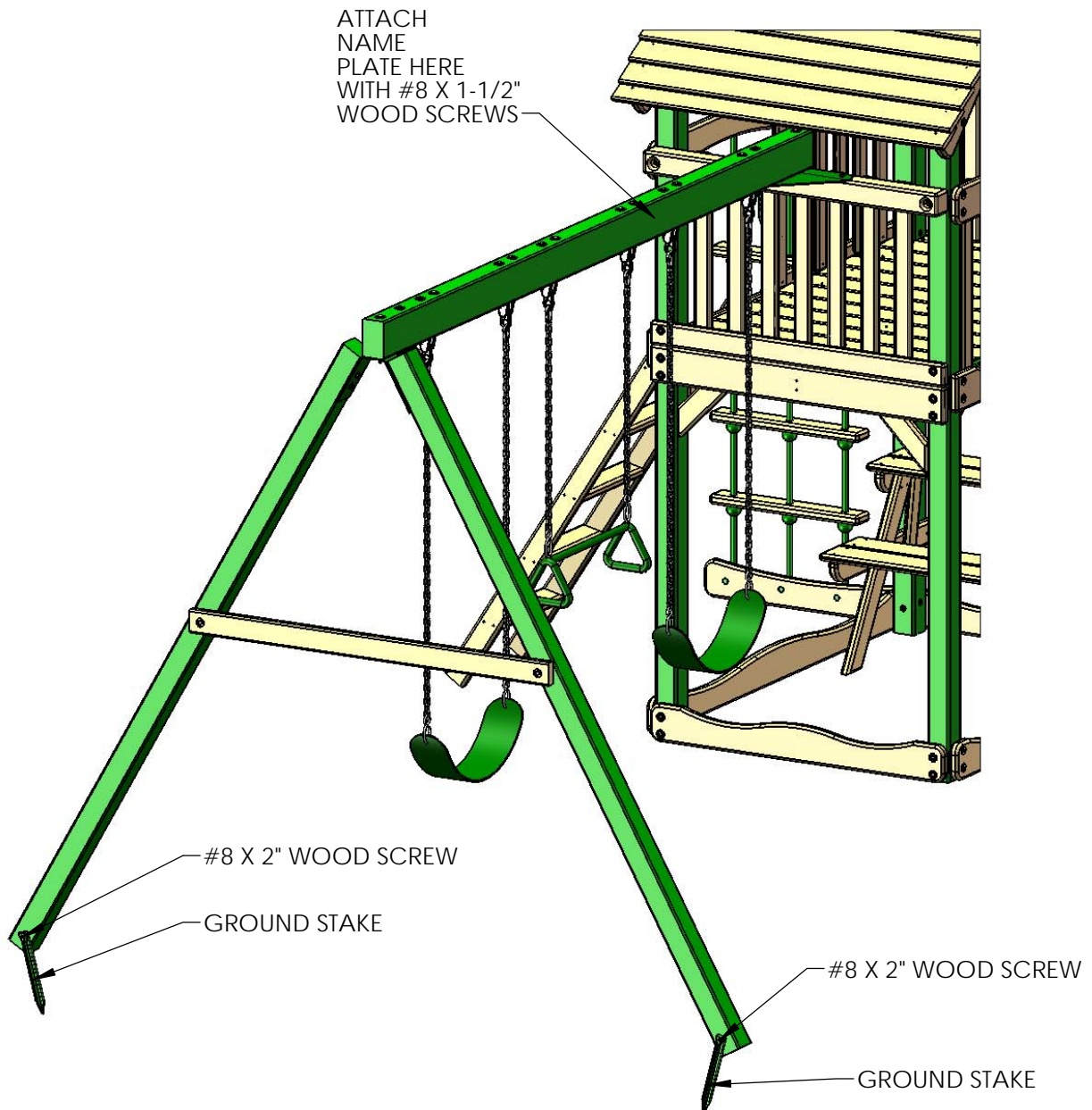

STEP 54: SAFETY BOARD

1: ATTACH THE 2 X 4 X 47-1/2" SAFETY BOARD TO THE LEFT CORNER POSTS NEAR THE SWINGS. THIS BOARD IS A VISUAL DETERRENT AND IS MEANT TO PREVENT CHILDREN FROM RUNNING THROUGH THE BASE OF THE PLAY SET INTO OTHER CHILDREN ON THE SWINGS.

2: PLACE THE TOP OF THE SAFETY BOARD 24" UP FROM THE BOTTOM OF THE 2 X 6 BOARD. HOLES IN THE SAFETY BOARD SHOULD BE OFFSET UP.

3: FASTEN THE SAFETY BOARD TO THE CORNER POSTS WITH 5/16" X 3-1/2" LAG SCREWS AND 5/16" WASHERS.

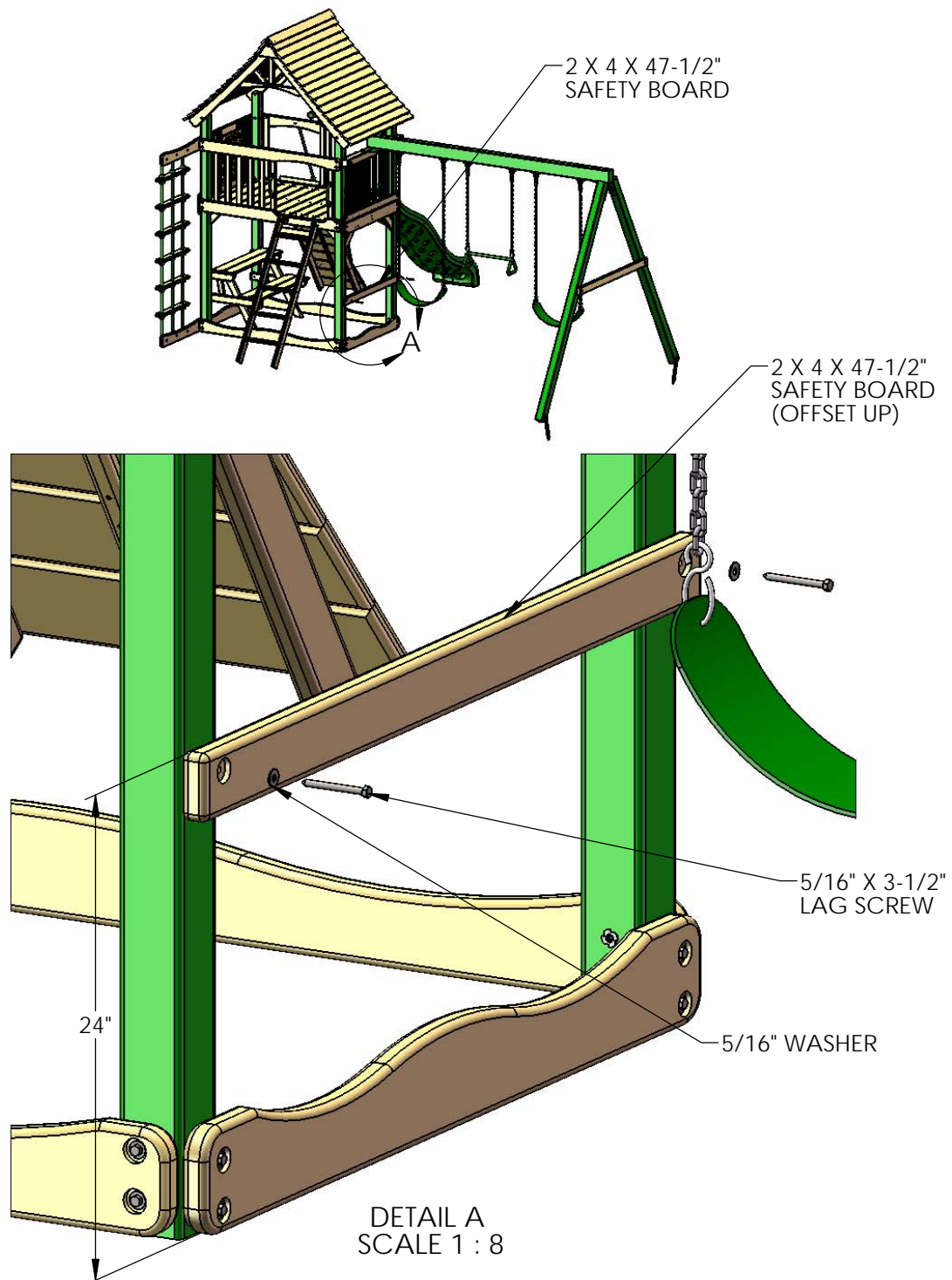

STEP 55: STEERING WHEEL

1: PLACE THE STEERING WHEEL INSERT INSIDE THE STEERING WHEEL. PLACE THE STEERING WHEEL AGAINST THE END OF THE SWING BEAM.

2: MARK THROUGH THE HOLE IN THE STEERING WHEEL INSERT ONTO THE END OF THE SWING BEAM. DRILL A 3/16" PILOT HOLE 2" DEEP INTO THE SWING BEAM.

3: USE THE 2-1/2" LAG SCREW AND WASHER TO FASTEN THE STEERING WHEEL TO THE SWING BEAM. DO NOT OVER-TIGHTEN THE LAG SCREW OR THE STEERING WHEEL WILL NOT TURN.

4: PLACE THE STEERING WHEEL CAP OVER THE CENTER OF THE STEERING WHEEL AND SNAP IT INTO THE STEERING WHEEL INSERT.

