

# Sweetwater III

**Model: 2450**  
(BOXES: 2450-1, 2450-2,  
Accessory Box and Slide)

Copyright © 2018 PlayNation Play Systems  
All Rights Reserved



**52-2107-T**

190 Etowah Industrial Court  
Canton, GA 30114  
[www.playnation.com](http://www.playnation.com)

REV: 11.13.2018

-NOTICE-

This playset is intended for residential use only. It is not intended nor warranted for either public or commercial use.



Please inspect and inventory all parts immediately upon accepting delivery. Use the inventory pages in the manual to make sure you have received all necessary parts. The quickest method to get any parts that are missing or damaged is use our “Quick Response Center” located at:

**[www.playnation.com/support](http://www.playnation.com/support)**

DO NOT RETURN THIS PRODUCT TO THE RETAILER OR CONTACT THE RETAILER DIRECTLY. THE RETAILER DOES NOT STOCK COMPONENTS.

**PLEASE RETAIN ALL INSTRUCTIONS FOR FUTURE REFERENCE. KEEP THEM IN A SAFE PLACE WHERE YOU CAN REFER TO THEM AS NEEDED. CHECK FOR REVISED INSTRUCTIONS AT:**

**<http://www.playnation.com/manuals.html>**

**MANUFACTURER'S LIMITED LIFETIME WARRANTY**

PlayNation Play Systems warrants its Lifetime™ series of swing sets to be free from defects in workmanship and materials, under normal use and conditions, for the lifetime of the product for above ground structural wood components and for two years for all other components (e.g., swings, hardware, plastics, tarps, rope ladder, etc.) except PlayNation's Super Scoop Slides™ and Super Tube Spiral Slides™.

PlayNation warrants its Super Scoop Slides™ and Super Tube Spiral Slides™ to be free from defects in workmanship and materials, under normal use and conditions, for the lifetime of the product.

PlayNation warrants its Regal™, Imperial™, and Empire™ series swing sets to be free from defects in workmanship and materials, under normal use and conditions, for a period of 15 years for above ground structural wood components and for two years for all other components (e.g., swings, hardware, plastics, tarps, rope ladder, etc.).

PlayNation warrants all remaining products, including but not limited to its Free Standing Swing Set, Free Standing Tire Swing, See-Saw, Children's Picnic Table with Umbrella, Play-Zee-Bo™ and spring riders to be free from defects in workmanship and materials, under normal use and conditions, for a period of 1 year. All accessories purchased separate from those included with one of our swing set packages have a one year limited warranty.

**Cosmetic imperfections and natural tendencies of wood such as peeling, splintering, warping, seasonal checking or cracking, knots or knot holes, etc. are normal characteristics of all outdoor wooden play equipment and are not covered by this warranty. Checks or cracks in wood components that do not affect the intended function of the part, piece or overall swing set are not covered under this warranty.**

Wood rot or decay that develops because the product was installed in an area with poor drainage is not covered under this warranty. Lumber that has been damaged by wood boring bees, or conditions that develop as a result of faulty or improper installation of the product, are not covered by this warranty. Fading of stain, discoloration or mold on any wood part or accessory is not covered by this warranty. Cracks in plastic components, surface rust on hardware and chips on powder coated materials are not considered defects in material as long as they do not affect the functionality or structural integrity of the part or component.

It is the owner's responsibility to maintain the swing set. **This includes but is not limited to staining and sealing the lumber as needed and regular inspection to be sure all hardware is tight.** Instructions for proper maintenance can be found on PlayNation's website. Imperfections or conditions that develop because of a failure to properly maintain the swing set are not covered by this warranty.

PlayNation will, at its discretion, replace any above ground part within the stated warranty period that is defective in workmanship or materials. This decision is subject to verification of the defect, which, at PlayNation's discretion, may be accomplished by submitting photographs or by delivery of the defective part to PlayNation. PlayNation Play Systems • 190 Etowah Industrial Ct. • Canton, GA 30114 • 770-704-9300 Monday to Friday 9AM-5PM EST. Any warranty claim must include proof of purchase, including the date of purchase. **In addition, within the first 30 days from the date of purchase, PlayNation will replace any parts discovered to be missing from or damaged in the original packaging.**

This warranty is valid only if the product is used for the purpose for which it was designed and installed at a residential, single-family dwelling. This warranty is void if the product is used in a commercial, institutional or multi-family setting. **This warranty does not cover normal wear and tear or (a) products that have been damaged by acts of God and/or nature, negligence, misuse or accident; (b) products that have been modified or repaired by unauthorized persons; (c) the cost of labor; or (d) the cost of shipping any replacement product or part.**

PLAYNATION DISCLAIMS ALL OTHER REPRESENTATIONS AND WARRANTIES OF ANY KIND, EXPRESSED, IMPLIED, STATUTORY OR OTHERWISE, INCLUDING THE IMPLIED WARRANTIES OF MERCHANTABILITY AND FITNESS FOR A PARTICULAR PURPOSE. PLAYNATION WILL NOT BE LIABLE FOR ANY INCIDENTAL OR CONSEQUENTIAL DAMAGES. This warranty is non-transferable and does not extend to the owners of the product subsequent to the original purchaser. Some states do not allow limitations on implied warranties or exclusion of incidental or consequential damages, so these restrictions may not be applicable to you. This warranty gives you specific legal rights. You may also have other rights which vary from state to state.

# IMPORTANT SAFETY GUIDELINES

This product is recommended for use by children ages 3-11. This product is intended for residential use only and not intended for use in any public setting. A safety surface such as mulch or recycled tire should be used under the play set to prevent injury from falls. Also a 6 foot safety zone should be used around the entire play set.

As with any home project, good judgment and respect for power tools will greatly reduce the risk of injury. PlayNation recommends you follow all tool manufacturers' safety guidelines. Always wear eye protection and safety gloves to prevent injury. In several phases of construction two people may be required for lifting and securing of lumber. While the play set is being constructed, please keep children off the equipment until the project is complete. Bolts and screw heads should be checked regularly for tightness. The ground ladder, rope ladder, slide, swings and other areas where children spend a majority of their playtime should be checked more frequently.

PlayNation shall not be liable for incidental, indirect or consequential damages or injuries that result from the building and/or playing on our play sets. Adult supervision is recommended anytime a play set is being used.

## WEIGHT LIMITS FOR PLAYNATION PLAYSETS

- FORT PLATFORMS: 800 LBS. TOTAL WEIGHT
- SWING BELT: 225 LBS.
- TANDEM SWINGS: 70 LBS. PER CHILD. UP TO 140 LBS TOTAL WEIGHT.
- TRAPEZE: 125 LBS.
- FULL BUCKET SWING/ HALF BUCKET SWING: 50 LBS.
- HEAVY DUTY TODDLER BUCKET SWING: 85 LBS.
- INFANT SWING: 35 LBS.
- TIRE SWING: 125 LBS. TOTAL WEIGHT
- ROPE LADDER: 75 LBS.
- ROCK WALL: 150 LBS.
- CLIMBING RAMP: 150 LBS.
- MONKEY BARS: 175 LBS.
- ALL SLIDES: 150 LBS.

PlayNation recommends that the weight limits for all components must not be exceeded. Failure to adhere to these and other safety guidelines could result in damage to the play set and injury to the users.

**THIS PAGE INTENTIONALLY LEFT BLANK**

# PRODUCT REGISTRATION

- SWEETWATER III -

PlayNation™ manufactures the finest quality products that are designed for outstanding strength and durability. We back our products with an unparalleled warranty. In the unlikely event that you will need to contact us about covered repairs, we must have a valid Product Registration on file.

3 EASY WAYS TO REGISTER	
<b>OPTION 1</b>	Complete the online registration form at: <b><a href="http://www.playnation.com/register">http://www.playnation.com/register</a></b>
<b>OPTION 2</b>	Fax this completed form to: <b>(678) 880-3300</b>
<b>OPTION 3</b>	Mail this completed form to: <b>PlayNation Playsets</b> <b>190 Etowah Industrial Court</b> <b>Canton, GA 30114</b>

## Where did you buy this product?

Date of Purchase \_\_\_\_\_ Store \_\_\_\_\_ Store City \_\_\_\_\_ Store State \_\_\_\_\_

## Your registration information:

Name: \_\_\_\_\_ Email: \_\_\_\_\_

Address: \_\_\_\_\_

Street		City	State	Zip
Please select your age	<input type="checkbox"/> 18-30 <input type="checkbox"/> 41-50 <input type="checkbox"/> 31-40 <input type="checkbox"/> 51+	How would you rate the quality of this product?	<input type="checkbox"/> ★ ★ ★ ★ ★ Excellent <input type="checkbox"/> ★ ★ ★ ★ Above Average <input type="checkbox"/> ★ ★ ★ Average <input type="checkbox"/> ★ ★ Below Average <input type="checkbox"/> ★ Poor	
How old are your children?	<input type="checkbox"/> 2-3 <input type="checkbox"/> 6-7 <input type="checkbox"/> 4-5 <input type="checkbox"/> 8+			
Number of children	<input type="text"/>			

Would you recommend this product to friends & family?  Yes  No

May we add you to our mailing list?  Yes  No

May we use your comments on websites or other marketing materials?  Yes  No

Comments: \_\_\_\_\_  
\_\_\_\_\_  
\_\_\_\_\_

**THIS PAGE INTENTIONALLY LEFT BLANK**



## **IMPORTANT – PLEASE READ**

Congratulations! You have just purchased one of the finest residential wooden swing sets available today. As with any wooden product that spends its entire life outside, in varying elements, it is important to know what to expect with your new swing set so that your family can enjoy it for many years.

As your swing set acclimates to its new environment, natural characteristics of the wood can show in the form of checks, or “cracks” in the lumber. In almost all cases this is normal and it will not affect the structural integrity of your play set and is not covered under warranty.

## **KEEPING YOUR PLAYSET LIKE NEW**

### **MUST DO's**

**The following owner responsibilities are crucial to the safety, integrity and aesthetic appeal of your swing set and may affect the warranty if not adhered to.**

#### **WITHIN 60 DAYS**

- Check and tighten Hex Bolts/T-nuts, Carriage Bolts/Lock-nuts, and Lag Screws within the first 60 days and then twice annually – once before each season and then once during the season.

#### **WITHIN 90 DAYS**

- Apply a **sealant** or **semi-transparent stain with sealant** within the first 90 days of owning the swing set. Our own Stain/sealant is available here: <https://playnation.com/playground-stain-sealant/>

Oil based stain or water based stain may be used. Should you choose to use other stain we suggest asking the product covering specialist at any number of specialty paint stores or home improvement centers for a product that would work best for your local environment. \*\* TIP – while the set is new, take a small board from your swing set to the store with you so they can color match the tint of the stain or sealant.

#### **SEASONAL REMINDERS**

- If your area experiences regular snowfall, remove your fabric tarp/canopy to avoid stretching, sagging or tearing of the material. Store it inside, folded up, and it will be as good as new when winter is over.
- If your area experiences extremely cold temperatures, remove swing belts and other pliable features to prolong the lifespan of these play activities.

### **OTHER TIPS**

- Spray swing hangers with Pam, Mazola or olive oil to stop squeaking; do not use petroleum based products such as WD-40 or motor oil.
- To repel yellow jackets and wasps, use a cotton ball and dab interior wooden corners underneath the play set deck with a liquid dish soap. Avoid using insecticides.
- To speed up the slide wipe the center of slide with wax paper every 2 - 3 weeks.

For additional safety and maintenance guidelines, please visit our website.



## IMPORTANT DOCUMENTS

### CUSTOMER MUST READ AND RETAIN

Please go to the following links and read important SAFETY information prior to using your new play structure.

<http://www.playnation.com/safety-and-maintenance.html>

<http://www.playnation.com/manuals.html> (Click on your specific model)

<http://www.playnation.com/warranty.html>

**NOTE:** Your children's safety is our #1 concern. Observing the following statements and warnings reduces the likelihood of serious injury. Please review these safety rules regularly with your children.

#### **WARNING:**

***Children must NOT use this play set until it has been completely assembled and inspected by an adult to ensure it has been properly installed***

PlayNation Play Systems  
190 Etowah Industrial Court  
Canton, GA. 30114



**Model: 2450**

(BOXES: 2450-1, 2450-2,  
Accessory Box and Slide)

REV: 11.13.2018

# TABLE OF CONTENTS

Safety Guidelines.....	Page 3-7
Leveling Fort, General Information and Definitions.....	Pages 7-9
How to Install T-nuts, Swing Beam Loading.....	Pages 10-12
Site Plan, Safety Zones, Required Tool List and Kit Contents.....	Pages 13-15
Hardware, Lumber and Accessory Checklists.....	Pages 16-29
Corner Post Layout and Adding T-Nuts to Corner Posts.....	Steps 1-2
Framing Fort.....	Steps 3-9
Attaching Deck Boards/Deck Spacers and Deck Stringer.....	Steps 10-11
Angle Support Installation.....	Step 12
Panel Boards, Panel Supports and Arch Face Board.....	Steps 13-14
Building and Mounting Rockwall/Ladder Combination.....	Steps 15-18
Swing Beam Assembly.....	Steps 19-24
Panel Slat Installation.....	Steps 25-26
Center Posts, Front Wall and Windows, Framing Tarp.....	Steps 27-30
Sun/Sunburst, Tarp and Roof Peak Support Installation.....	Steps 31-33
Tic Tac Toe, Steering Wheel, Chalkboard.....	Steps 34-37
Climbing Rope.....	Step 38
Flag Kits.....	Step 39
Slide Block.....	Step 40
Safety Handles.....	Step 41
Bottom Panel Board and Panel Slats.....	Steps 42-43
Slide.....	Step 44
Swings and Name Plate.....	Step 45
Periscope and Telescope.....	Steps 46-47
Ground Stakes.....	Step 48
Sandbox Seats.....	Step 49

**PLEASE READ OWNER'S MANUAL CAREFULLY BEFORE STARTING ASSEMBLY!**

# Safety and Maintenance Tips for Your New Play Set:

**NOTE: Your children's safety is our #1 concern. Observing the following statements and warnings reduces the likelihood of serious or fatal injury. Please review these safety rules regularly with your children.**

- This play set is designed for the use of 4 occupants who have a combined weight not exceeding 800 pounds on the elevated floor, 3 occupants who have a combined weight of 425 pounds on the swing area, for a total Unit capacity of 7 occupants who have a combined weight of 1225. (This weight does not include any picnic table area(s).)
- On-site adult supervision is required.
- Teach children not to walk close to, in front of, behind, or between moving swings or other moving playground equipment.
- Teach children to sit in and never stand on swings
- Teach children not to twist the chains and ropes and not to loop them over the swing beam, since this may reduce the strength of the chain or rope.
- Teach children not to jump from swings or other playground equipment in motion.
- Teach children not to push empty seats. The seat may hit them and cause serious injury.
- Teach children to sit in the center of the swings with their full weight on the seats.
- Teach children not to use the equipment in a manner other than intended.
- Teach children to always go down slides feet first. Never slide headfirst.
- Teach children to look before they slide to make sure no one is at the bottom.
- Teach children to never run up a slide, as this increases their chances of falling.
- The parents should have the children dress appropriately with well-fitting shoes. Loose clothing such as scarves and ponchos should not be worn. Always take off, tie up or tuck in cords and drawstrings on children's clothing. These things can get caught on playground equipment and strangle a child.
- Teach children not to climb when the equipment is wet.
- Teach children to never jump from a fort deck. They should always use the ladder, ramp or slide.
- Teach children to never crawl or walk across the top of monkey bars or swing beam.
- Teach children to never crawl on top of a fort roof or on the outside of a tube slide.
- Verify that any suspended climbing ropes, chains, or cables are secured at both ends and that they cannot be looped around an adult hand.
- Teach children not to attach items to the playground equipment that are not specifically designed for use with the equipment, such as, but not limited to, jump ropes, clothesline, pet leashes, cables and chain as they may cause a strangulation hazard.
- Teach children to never wrap their legs around swing chain.
- Teach children to never slide down the swing chain.
- Teach children to remove their bike or other sports helmet before playing on the playground equipment.
- Teach children to NEVER look at the sun or other bright light through any accessory such as but not limited to a telescope, periscope or binoculars.
- Never add extra length to chain or rope. The chains or ropes provided are the maximum length designed for the swings.

**WARNING: Children must NOT use this play set until it has been completely assembled and inspected by an adult to insure it has been properly installed and the swing beam legs are anchored.**

# **Safety and Maintenance Tips for Your New Play Set: (continued)**

Playgrounds should be inspected on a regular basis. If any of the following conditions are noted, they should be removed, corrected, or repaired immediately to prevent injuries.

- Hardware that is loose, worn or that has protrusions or projections.
- Exposed equipment footings.
- Scattered debris, litter, rocks, or tree roots.
- Splinters, large cracks, and decayed wood components.
- Deterioration and corrosion on structural components, which connect to the ground.
- Missing or damaged equipment components, such as handholds, guardrails, swing seats.
- Check all nuts and bolts twice monthly during the usage season and tighten as required. (But not so tight that you crack the wood) We recommend you check the swing beam and hardware often due to wood expansion and contraction. It is particularly important that this procedure be followed at the beginning of each season.
- Remove plastic swing seats and take indoors or do not use when the temperature drops below 32°F. Reinstall swings and other swing equipment at the beginning of the usage season.
- Oil all metallic moving parts monthly during the usage period.
- Check all coverings for bolts and sharp edges twice monthly during usage season to be certain they are in place. Replace when necessary. It is especially important to do this at the beginning of each new season.
- Check swing seats, ropes, cables and chains monthly during usage season for evidence of deterioration. Replacement should be made of any swing seat that has developed cracks in the plastic seats. Ropes, cables and chains should be removed and replaced if excessive wear is found. Contact us for warranted replacement parts.
- Swing chains, rings, ropes, etcetera should always be fastened to a rotating swing hanger. NEVER attach a chain, ring, rope, etcetera to a stationary hanger such as but not limited to an eye bolt. Severe wear could occur leading to an injury.
- For rusted areas on metallic members such as monkey bars, hand supports brackets, etc.; sand and repaint, using a non lead-based paint meeting the requirements of Title 16 C.F.R. Part 1303. These requirements are available at: <http://www.cpsc.gov/>
- Inspect wood parts monthly. The grain of the wood sometimes will lift in the dry season causing splinters to appear. Light sanding may be necessary to maintain a safe playing environment. If you are treating your play set with stain regularly, it will help prevent severe checking/splitting and other weather damage.
- Once or twice a year, depending on your climate conditions, you must apply some type of protection (sealant) to the wood of your unit. Prior to the application of sealant, lightly sand any “rough” spots on your set. Please note this is a requirement of your warranty.
- Creating and maintaining the play set on a level location is very important. As your children play, your play set will slowly dig its way into the soil, and it is very important that it settles evenly. Make sure the play set is level and true once each year or at the beginning of each play season.
- Twice a month during the usage season rake the playground protective surfacing materials to prevent compaction and maintain appropriate depths. Replace the protective surfacing materials as required.
- Disposal Instructions: When the play set is no longer desired, it should be disassembled and disposed of in such away that no unreasonable hazards will exist at the time the play set is discarded.

# PLAYGROUND SURFACING MATERIALS

## SECTION 4 OF THE CONSUMER PRODUCT SAFETY COMMISSION'S OUTDOOR HOME PLAYGROUND SAFETY HANDBOOK<sup>9</sup>

### Select Protective Surfacing

One of the most important things you can do to reduce the likelihood of serious head injuries is to install shock-absorbing protective surfacing under and around your play equipment. The protective surfacing should be applied to a depth that is suitable for the equipment height in accordance with ASTM Specification F 1292. There are different types of surfacing to choose from; whichever product you select, follow these guidelines:

**NOTE:** Do not install home playground equipment over concrete, asphalt, or any other hard surface. A fall onto a hard surface can result in serious injury to the equipment user. Grass and dirt are not considered protective surfacing because wear and environmental factors can reduce their shock absorbing effectiveness. Carpeting and thin mats are generally not adequate protective surfacing. Ground level equipment – such as a sandbox, activity wall, playhouse or other equipment that has no elevated play surface – does not need any protective surfacing.

### Loose-Fill Materials:

- Maintain a minimum depth of 9 inches of loose-fill materials such as wood mulch/chips, engineered wood fiber (EWF), or shredded/recycled rubber mulch for equipment up to 8 feet high; and 9 inches of sand or pea gravel for equipment up to 5 feet high. NOTE: An initial fill level of 12 inches will compress to about a 9-inch depth of surfacing over time. The surfacing will also compact, displace, and settle, and should be periodically refilled to maintain at least a 9-inch depth.
- Use a minimum of 6 inches of protective surfacing for play equipment less than 4 feet in height. If maintained properly, this should be adequate. (At depths less than 6 inches, the protective material is too easily displaced or compacted.)
- Use containment, such as digging out around the perimeter and/or lining the perimeter with landscape edging. Don't forget to account for water drainage. U.S. Consumer Product Safety Commission, Washington, D.C., 20207 or call the toll-free hotline :1-800-638-2772
- Check and maintain the depth of the loose-fill surfacing material. To maintain the right amount of loose-fill materials, mark the correct level on play equipment support posts. That way you can easily see when to replenish and/or redistribute the surfacing.
- Do not** install loose fill surfacing over hard surfaces such as concrete or asphalt.

### Poured-In-Place Surfaces or Pre-Manufactured Rubber Tiles:

You may be interested in using surfacing other than loose-fill materials – like rubber tiles or poured-in-place surfaces.

- Installations of these surfaces generally require a professional and are not "do-it-yourself" projects.
- Review surface specifications before purchasing this type of surfacing. Ask the installer/manufacture for a report showing that the product has been tested to the following safety standard: ASTM F 1292 Standard Specification for Impact Attenuation of Surfacing Materials within the Use Zone of Playground Equipment. This report should show the specific height for which the surface is intended to protect against serious head injury. This height should be equal to or greater than the fall height – vertical distance between a designated play surface (elevated surface for standing, sitting, or climbing) and the protective surfacing below – of your play equipment.
- Check the protective surfacing frequently for wear.

### Placement

Proper placement and maintenance of protective surfacing is essential. Be sure to

- Extend surfacing at least 6 feet from the equipment in all directions.
- For to-fro swings, extend protective surfacing in front of and behind the swing to a distance equal to twice the height of the top bar from which the swing is suspended.
- For tire swings, extend surfacing in a circle whose radius is equal to the height of the suspending chain or rope, plus 6 feet in all directions.

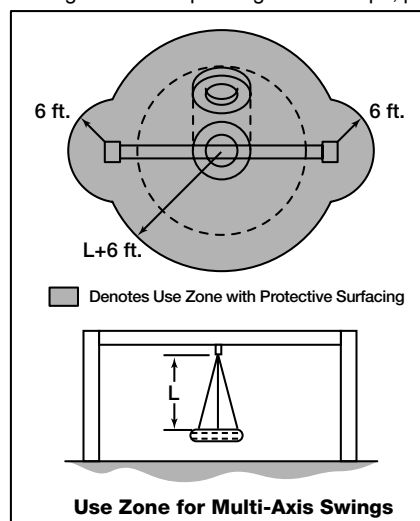
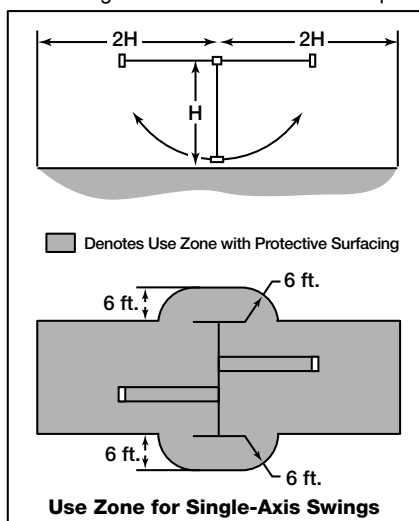

<sup>9</sup> This information has been extracted from the CPSC publications "Playground Surfacing—Technical Information Guide" and "Handbook for Public Playground Safety." Copies of these reports can be obtained by sending a postcard to the: Office of Public Affairs, U.S. Consumer Product Safety Commission, Washington, D.C., 20207 or call the toll-free hotline: 1-800-638-2772

# Play Set Surfacing Recommendations:

Below are some of the recommendations that the U.S. Consumer Product Safety Commission (CPSC) offers from its Handbook for Public Playground Safety. The guide can be downloaded in full at [www.cpsc.gov/PageFiles/122149/325.pdf](http://www.cpsc.gov/PageFiles/122149/325.pdf)

**1. Protective Surfacing** - Since almost 60% of all injuries are caused by falls to the ground, protective surfacing under and around all playground equipment is the most critical safety factor on playgrounds.

Certain manufactured synthetic surfaces also are acceptable; however, test data on shock absorbing performance should be requested from the manufacturer.

Asphalt and concrete are unacceptable. They do not have any shock absorbing properties. Similarly, grass and turf should not be used. Their ability to absorb shock during a fall can be reduced considerably through wear and environmental conditions.

Certain loose-fill surfacing materials are acceptable. Surfacing materials are acceptable, such as the types and depths shown in the table.

## Fall Heights and Materials

Type Of Material	6 in. depth	9 in. depth	12 in. depth
Double-Shredded bark mulch	6' Fall Height	10' Fall Height	11' Fall Height
Wood Chips	6' Fall Height	7' Fall Height	12' Fall Height
Fine Sand	5' Fall Height	5' Fall Height	9' Fall Height
Shredded Tires*	10-12' Fall Height	N/A	N/A
Fine Gravel	6' Fall Height	7' Fall Height	10' Fall Height

\*This data is from tests conducted by independent testing laboratories on a 6-inch depth of uncompressed shredded tire samples produced by four manufacturers. The tests reported critical heights, which varied from 10 feet to greater than 12 feet. It is recommended that persons seeking to install shredded tires as a protective surface request test data from the supplier showing the critical height of the material when it was tested in accordance with ASTM F1292.

*It should be recognized that all injuries due to falls cannot be prevented no matter what surfacing material is used.*



**2. Fall Zones** - A fall zone, covered with a protective surfacing material, is essential under and around equipment where a child might fall. This area should be free of other equipment and obstacles onto which a child might fall. Stationary climbing equipment and slides should have a fall zone extending a Minimum of 6' in all directions from the perimeter of the equipment.

Swings should have a fall zone extending a minimum of 6' from the outer edge of the support structure on each side. The fall zone in front and back of the swing should extend out a minimum distance of twice the height of the swing as measured from the ground to the top of the swing support structure.

## LEVELING YOUR FORT DURING ASSEMBLY

- Complete the steps which will be the basic frame of the fort. {i.e. four corner posts with base (sand box boards) and deck supports}
- Position in the most level area chosen for the play set, keeping in mind the location and size of the swing beam, ladder, slides, etc. that extend off the fort.
- Once the frame is in the final position, check for vertical and horizontal levelness to determine which side(s) will need to be dug into the ground to level the play set.
- With a shovel, score the ground around the outside edges of the sandbox boards on the 'high' side of the fort. This is the area that will be dug in. Make sure to score deep enough; the scored lines will be your digging template.
- Push the frame off and away from the scored area, far enough to dig and remove dirt to reach the appropriate depth.
- Dig a channel along the scored line(s) for the base of the fort (corner post and sandbox boards) to rest into. Dig the channel(s) to the same level depth. The bottom of the channel(s) should be level to each other so your frame doesn't teeter or rock because the channel(s) are uneven.
- Once you have removed enough grass and dirt, slide/push the frame into the channel(s). Place a level on the vertical and horizontal boards of the frame to determine if enough soil, or too much, was removed.
- Repeat this process until the basic frame is plumb and level and in its final position before completing the rest of the assembly.
- Measure to make sure fort is square.

**Important: if you require a channel depth of more than 6", then we recommend you have your play set area professionally graded before completing assembly.**

*Example Play area:*

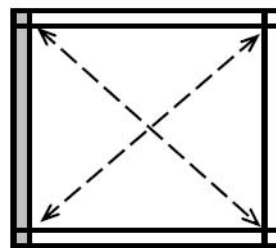
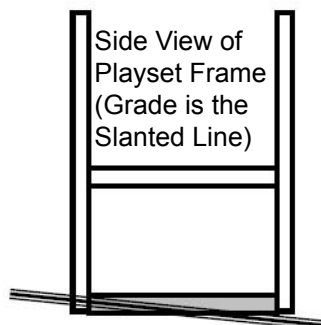

The diagonal measurements should be the same from corner post to corner post. If not, adjust corner posts so that the distance is equal.

■ = Area to be scored and channeled for levelness

# General Info to Review Before Installation

- Depending on your experience, assembly of the playset can take as little as 6 hours up to 24 hours, depending on size, after inventory of parts; therefore, we recommend you set aside a full two days for assembly.
- Identify all of the parts for your play set. Empty each box and lay out boards so you can see each part. Your instruction book will have detailed drawings that will make it easy for you to recognize individual parts. Keep all hardware and metal parts separate from wooden pieces.
- After everything is laid out, check carefully to ensure all parts are present. Make sure there are no broken boards.
- Find an area to sort your hardware. It is best to open the hardware on a solid surface so that you do not lose any pieces in the grass. This will save time and familiarize you with all the different pieces in the hardware bag.
- Important note: Wood has some natural defects such as knots, surface cracks, etc... We reject parts that are structurally defective. We use a high quality lumber in our structures; however, you should inspect each part for splinters or rough spots and sand them smooth to prevent injury.
- After familiarizing yourself with all of the components, read all instructions thoroughly. Reading instructions after you have studied the parts will help you understand the installation process, and help to eliminate unnecessary mistakes.
- Pay close attention to the diameter and length of each bolt and screw.
- Never tighten hardware completely at first. It helps to have some adjustment for bolt alignment while you are attaching parts together. After everything is square, tighten each joint.
- After the main unit is assembled it is critical that the floor is level and square. If the main frame is not level, the walls and floor will be out of square.
- After you complete installation, make sure every bolt, screw, and nut is tight, and every board is secure. Wood will expand and contract with the seasons.
- Place the set on level ground, not less than 6 feet from any structure or obstruction such as a fence, garage, house, overhanging branches, laundry lines, or electrical wires.

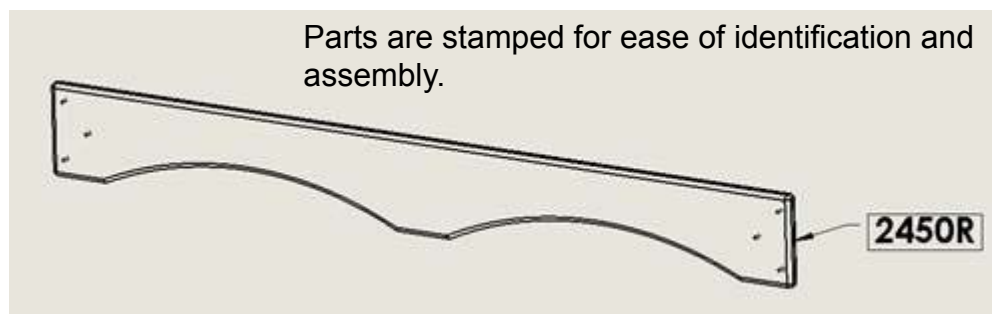

**This page is a list of definitions and explanations used throughout our instructions to aid you in the assembly of your play set.**

**Offset Holes-** Throughout the installation procedures we will refer to parts with offset holes. This refers to the orientation of the holes on the board. An offset hole is one that is closer to one side than it is the other or in other words, it is not centered on the board. In the procedures you will be instructed to attach the boards with the holes offset up or with the holes offset down. This refers to which side of the board the hole/holes should be closer to. Offset holes up= hole/holes will be closer to the top of the board. Offset holes down= hole/holes will be closer to the bottom of the board. Note: some parts do not have offset holes, but instead the holes are on center. Therefore there will not be any reference on how to offset these parts.

**EXAMPLE OF OFFSET HOLES UP**

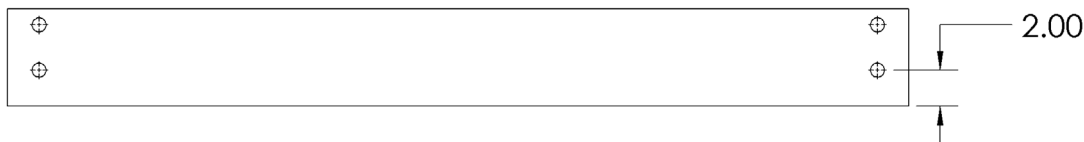

**EXAMPLE OF OFFSET HOLES DOWN**



**Counter-sunk holes** - Many of the parts that will be used have counter-sunk holes. A counter-sunk hole is one that surrounds one side of a through hole, but does not extend through the wood it's self. When using a counter-sunk hole the bolt will be inserted through the through hole and either the head of the bolt and washer or nut and washer will occupy the counter sunk hole.

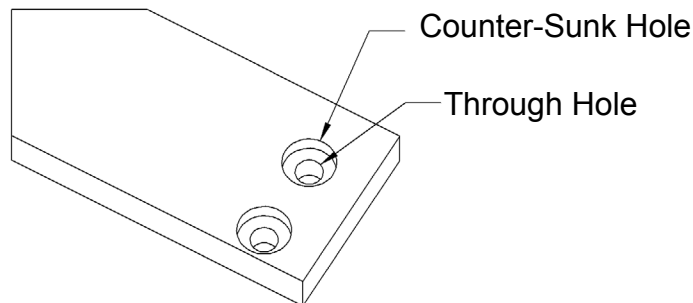

**Lag Screws-** Lag screws are used in the construction of our play sets to enhance the structural integrity of the unit. There will not be predrilled holes in the post for lag screw installation. Lag screws are self-tapping, though if you are using a manual socket wrench it may be advantageous to pre-drill a hole first. Instructions for this are provided on a separate page in the front of the manual. Be sure to tighten the lags completely when driving them in by hand. Power tools such as a heavy duty impact driver or large power drill should have enough torque to drive in the lag screws, but make sure not to over tighten as this can cause the threads to “strip out” in the post.

# Common Installation Practice Installing T-nuts

When installing T-nuts into the wood, use a smooth faced hammer to set the face of the T-nut flush into the wood.

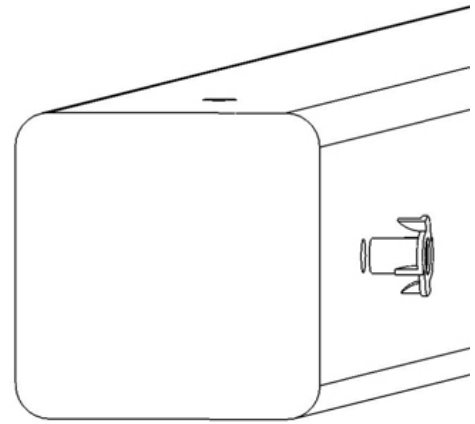
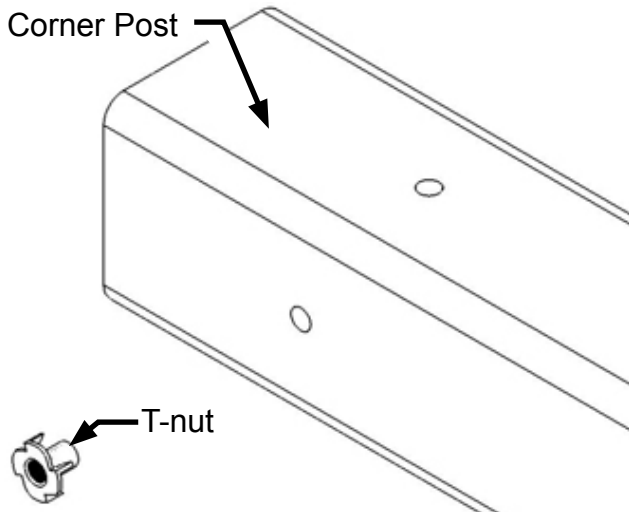

Insert the barrel of the T-nut into the predrilled hole. Using a smooth faced hammer, drive the T-nut until the face of the T-nut is flush to the wood.

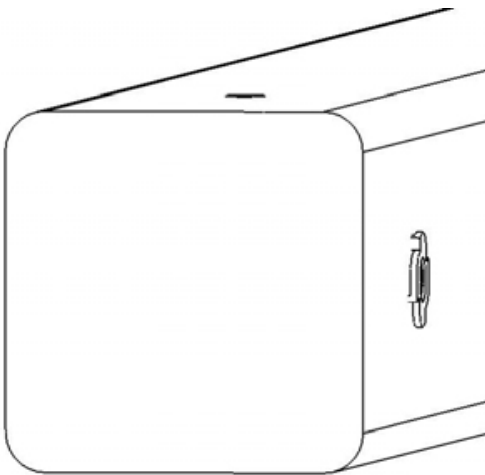

This picture shows the T-nut inserted and installed flush to the wood.

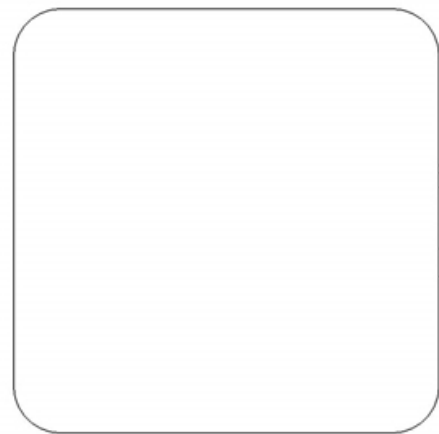

This picture shows an end view of the T-nut installed flush to the wood.

**WARNING: DO NOT EMBED THE TOP OF THE T-NUT INTO THE FACE OF THE WOOD**

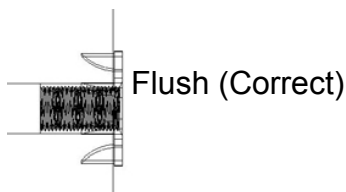

Cross Section end view, you are looking at an X-ray view of the post and T-nut. The barrel of the T-nut is in the corner post the line is the face of the wood.

# HOW A T-NUT WORKS

USUALLY THE FIRST STEP IN OUR ASSEMBLY INSTRUCTIONS IS TO INSERT T-NUTS INTO THE CORNER POSTS. A T-NUT IS A FASTENER WHICH IS THREADED ON THE INSIDE AND IT FUNCTIONS JUST LIKE A STANDARD HEX NUT. YOU INSERT THE T-NUTS INTO THE PREDRILLED HOLES IN THE CORNER POSTS.

THE T-NUT HAS A BARREL SHAPED END WHICH GOES INTO THE HOLE IN THE CORNER POST. THE T-NUT ALSO HAS A FLANGE SHAPED END WITH TEETH. THE TEETH PENETRATE INTO THE CORNER POST WOOD TO PREVENT THE T-NUT FROM SPINNING WHEN YOU TIGHTEN THE HEX HEAD BOLT.

SHOWN BELOW YOU WILL SEE THE T-NUT IS HAMMERED INTO THE CORNER POST ON THE BACK SIDE. THE BOARD IS BEING ATTACHED ON THE FRONT SIDE OF THE CORNER POST.

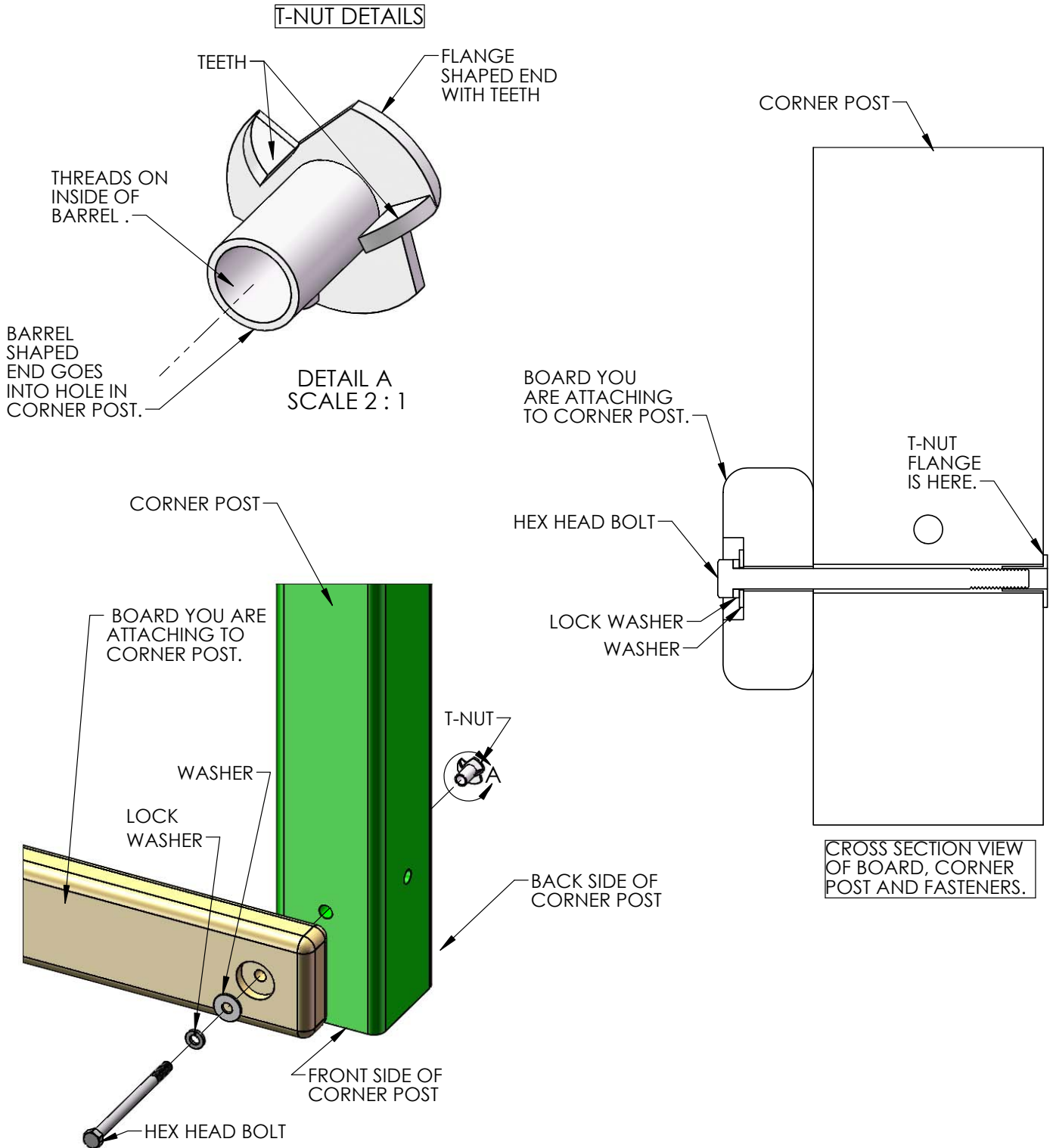

# SWING BEAM LOADING

## Weight Limits for Accessories:

The weight limit for a Swing Belt is 225 lbs. (Although 150lbs is the maximum recommended swinging weight capacity for the swing position.)

The weight limit for a Trapeze Bar is 125 lbs.

## Maximum Allowable swinging weight for a three position swing:

- 1) The maximum allowable swinging weight at each Swing Belt position is 150 lbs.
- 2) The maximum allowable swinging weight at the Trapeze position is 125 lbs.
- 3) The **MAXIMUM SWING BEAM LOAD IS 425 lbs.**

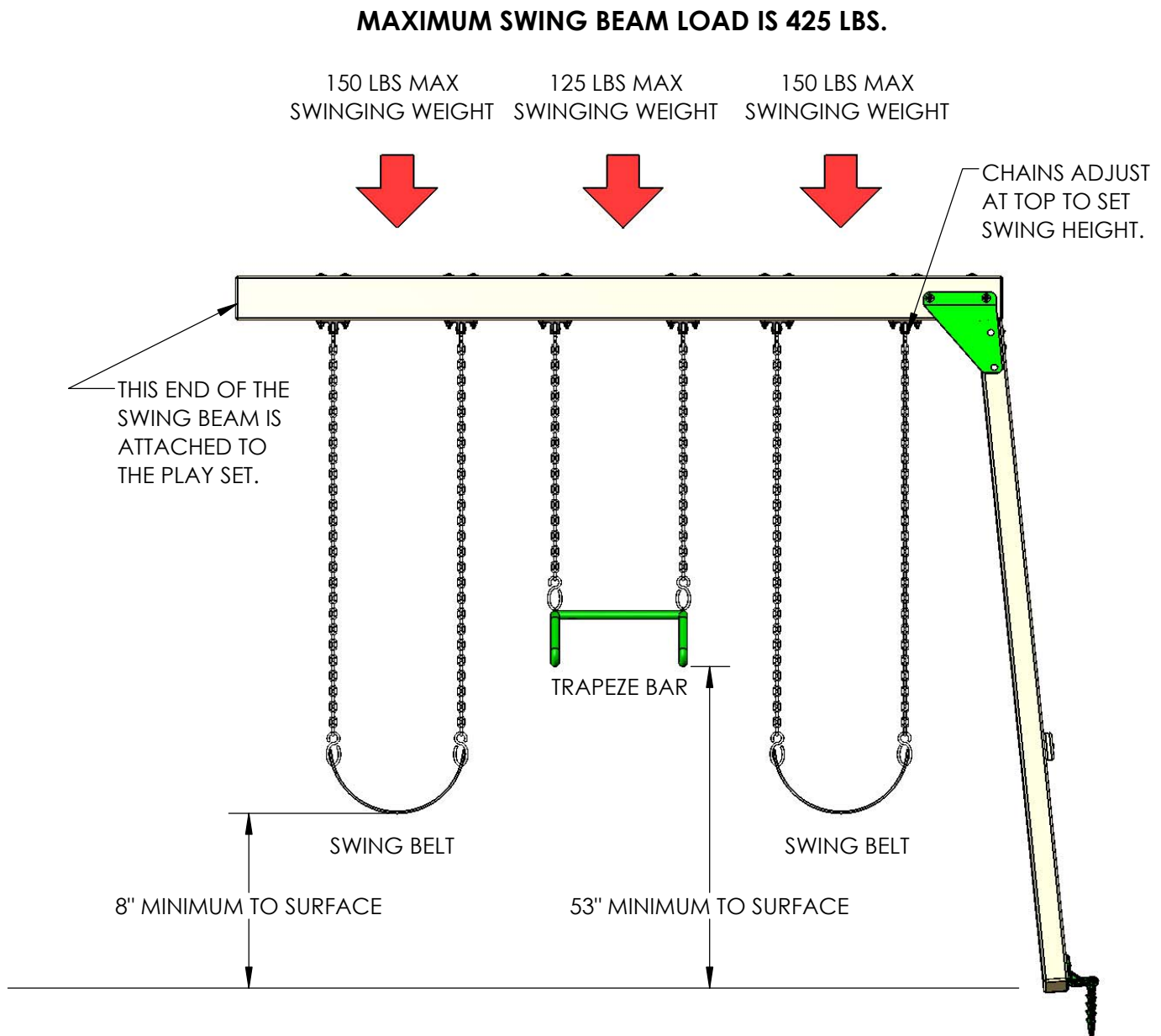

**Please familiarize yourself with the manual, parts/components and general construction process of your new playset before getting started.**

**SITE PLAN:**

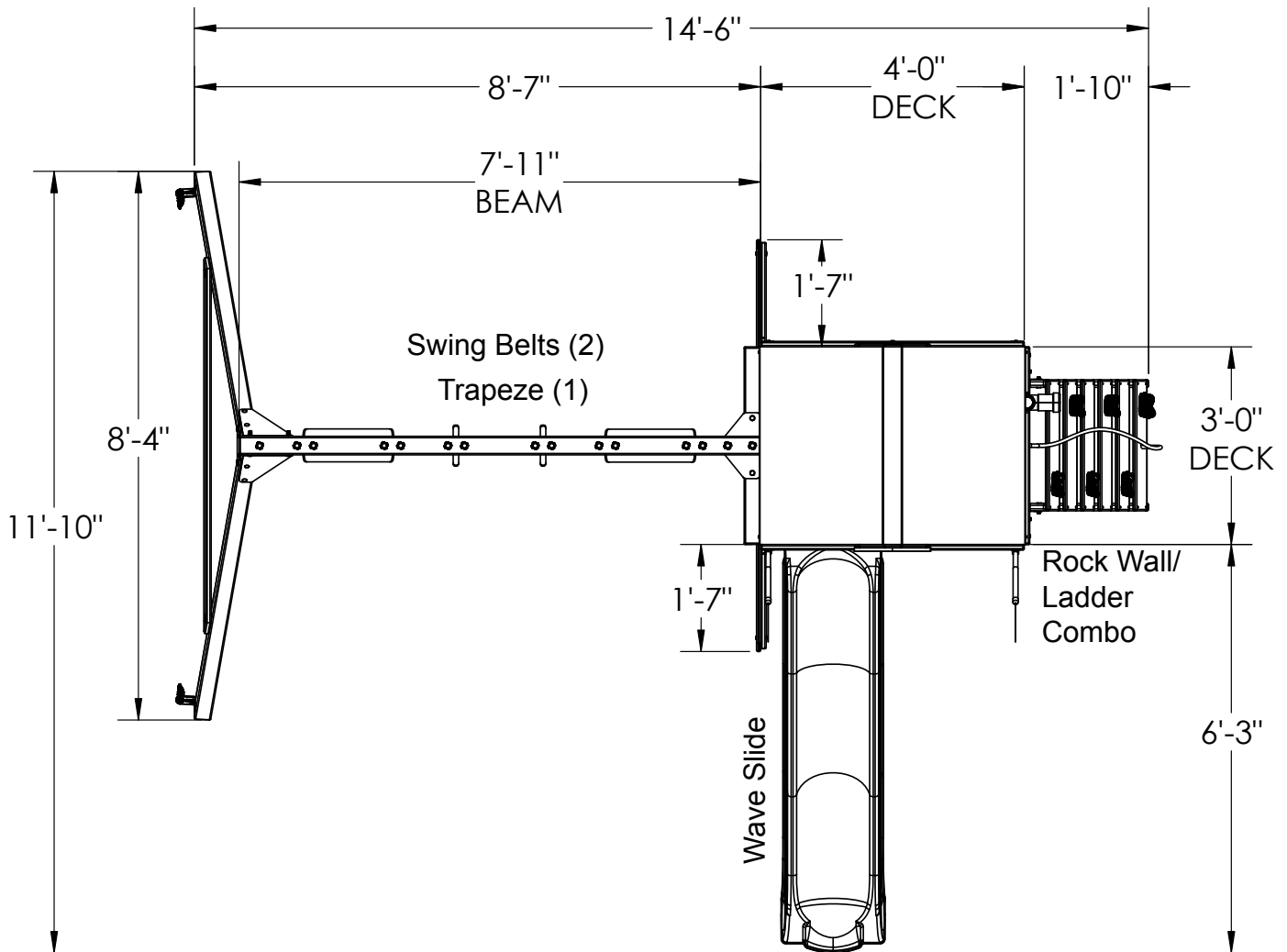

Playset height: 9' - 10-1/4"

Swing Beam height: 7' - 2-3/4"

Playset Fall height: 6' - 8-1/4"

Standing Height at center of deck: 5' - 9-3/4"

Standing Height at outer edge of deck: 4' - 3-5/8"

Deck height: 4'

Deck Size: 4' x 3'

Entry opening at rockwall/ladder combo: 2' - 6" wide x 2' - 1-5/8" high

Slide opening 1' - 7-5/16" wide x 2' - 1-7/16" high

Approximate assembly time: 6-8 hours

# SAFETY ZONES

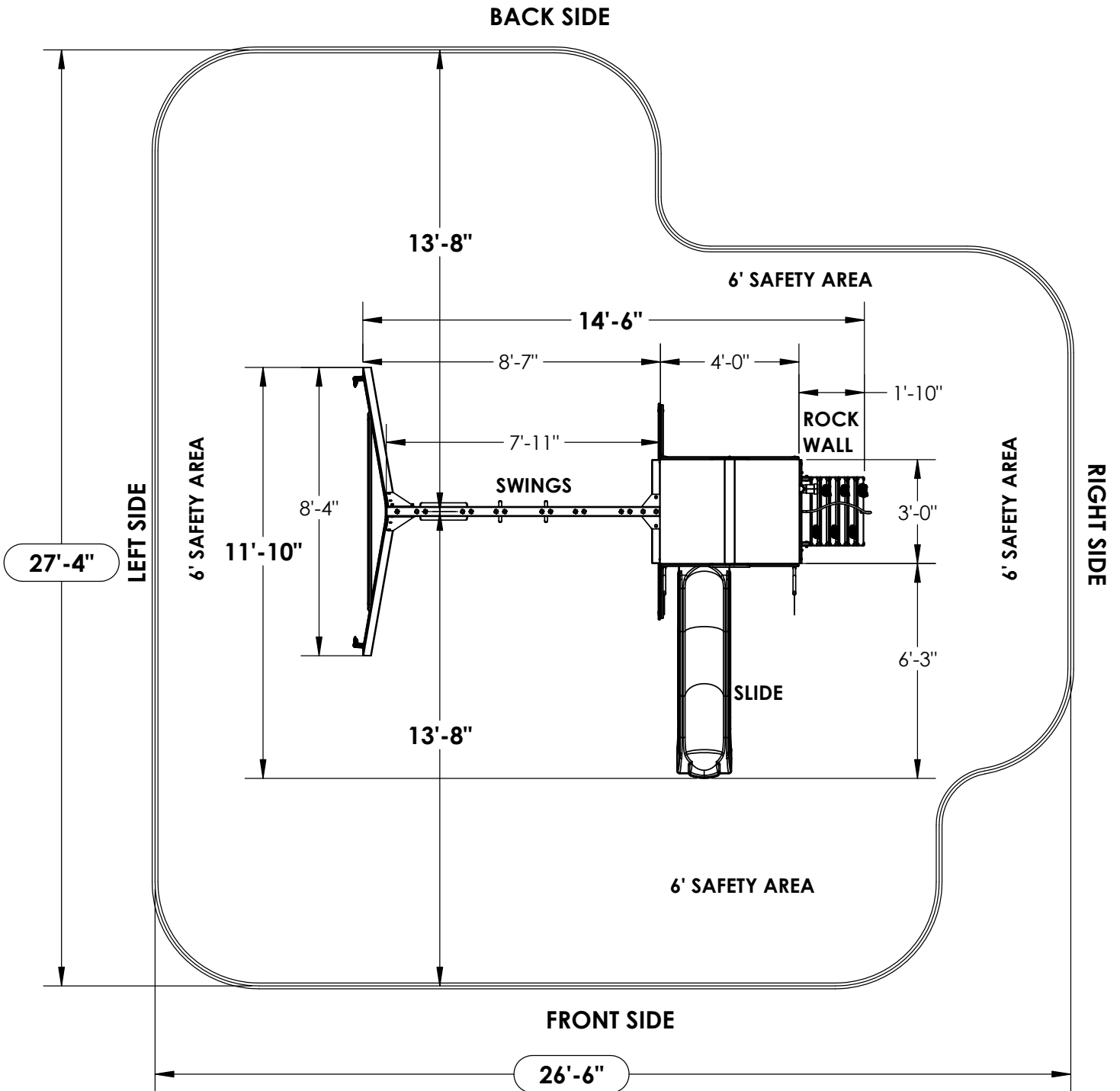



## **REQUIRED TOOL LIST:**

- \_\_\_ Standard or Cordless Drill w/ Phillips Bit (#2 square bit provided)
- \_\_\_ Drill Bits 1/8", 3/8"
- \_\_\_ 1/2" Wrench and Socket
- \_\_\_ 1/2" Deep Well Socket
- \_\_\_ Level
- \_\_\_ Tape Measure
- \_\_\_ Extension Cord (if using standard drill)
- \_\_\_ Hammer
- \_\_\_ Pencil
- \_\_\_ Locking Pliers (Vise Grips)
- \_\_\_ Shovel

## **KIT CONTENTS**

### **Swings, Slides, Accessories:**

- \_\_\_ (Qty ) Description
- \_\_\_ (2) Swingbelts w/ Chains
- \_\_\_ (1) Trapeze Swing w/ Chains
- \_\_\_ (1) Wave Slide
- \_\_\_ (6) Rock Wall Grips (assorted colors)
- \_\_\_ (1) Telescope
- \_\_\_ (1) Periscope
- \_\_\_ (1) Crown
- \_\_\_ (1) Steering Wheel
- \_\_\_ (2) Safety Handle (1 pair)
- \_\_\_ (1) Tic Tac Toe
- \_\_\_ (2) Flag (1 pair)
- \_\_\_ (1) Tarp 05-0014
- \_\_\_ (1) Chalkboard
- \_\_\_ (3 pair) Ground Stakes
- \_\_\_ (2) Plastic Dormer Window 07-0029-G

### **Fort Hardware:**

*see following pages*

### **Swing Beam Hardware:**

*see following pages*

### **Wood Components:**

*see following pages*

#8 X 3" WOOD SCREW  
 QTY: 24

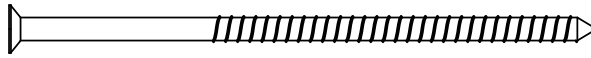

#8 X 2-1/2" WOOD SCREW  
 QTY: 100

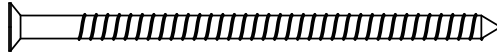

#8 X 2" WOOD SCREW  
 QTY: 70

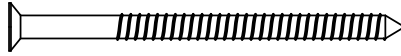

#8 X 1-1/2" WOOD SCREW  
 QTY: 38

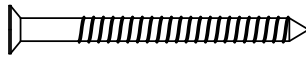

#8 X 1-1/4" WOOD SCREW  
 QTY: 80

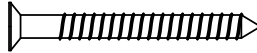

#8 X 1" WOOD SCREW  
 QTY: 14

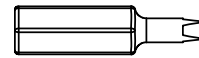
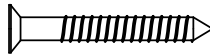

#2 SQUARE  
 DRIVE BIT  
 QTY: 1

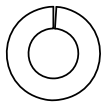

1/4" SPLIT  
 LOCK WASHER  
 QTY: 2

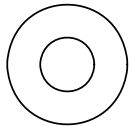

1/4" FLAT  
 WASHER  
 QTY: 14

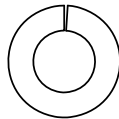

5/16" SPLIT  
 LOCK WASHER  
 QTY: 35

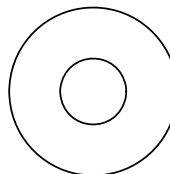

5/16" FLAT  
 WASHER  
 QTY: 35

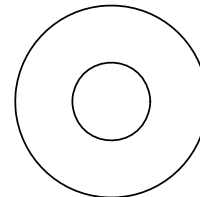

3/8" FLAT  
 WASHER  
 QTY: 30

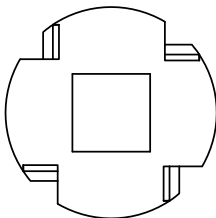

3/8" TORQUE WASHER  
 QTY: 18

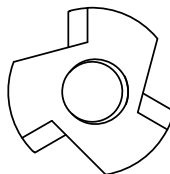

5/16" T-NUT  
 QTY: 35

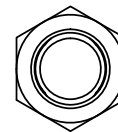

3/8" LOCK NUT  
 QTY: 30

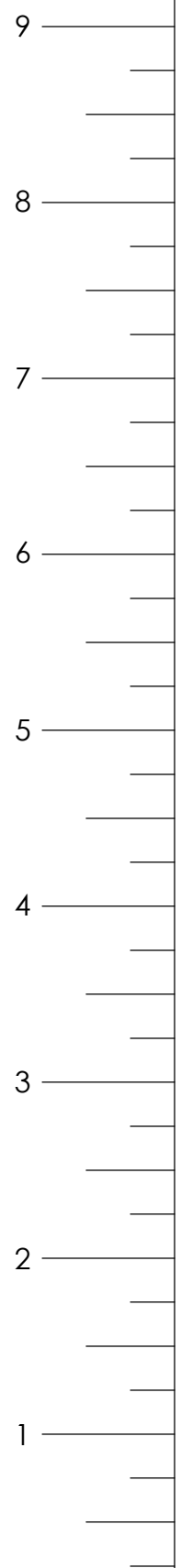

USE THE RULER TO THE RIGHT TO MEASURE YOUR BOLTS AND SCREWS. PICTURE VIEWS SHOWN ABOVE ARE 1:1 SCALE AND CAN BE USED TO MATCH BOLT AND SCREW SIZES.

5/16" X 3-3/4" HEX BOLT  
 QTY: 12

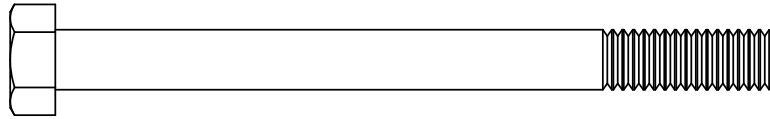

9

5/16" X 3-1/2" HEX BOLT  
 QTY: 12

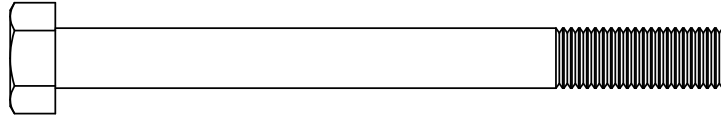

8

5/16" X 2" HEX BOLT  
 QTY: 2

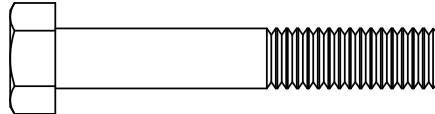

7

5/16" X 1-3/4" HEX BOLT  
 QTY: 2

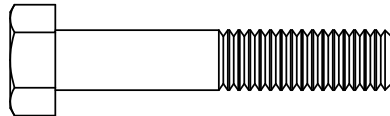

6

5/16" X 1-1/2" HEX BOLT  
 QTY: 2

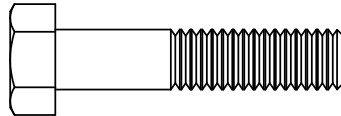

5

5/16" X 1" HEX BOLT  
 QTY: 2

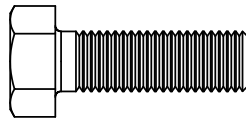

4

#14 X 2-1/2" PAN HEAD SCREW  
 QTY: 2

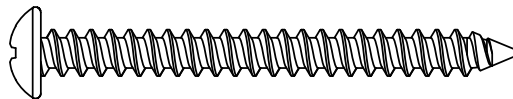

2

#14 X 1" PAN HEAD SCREW  
 QTY: 14

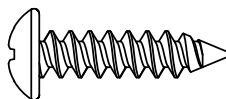

1

USE THE RULER TO THE RIGHT TO MEASURE YOUR BOLTS AND SCREWS. PICTURE VIEWS SHOWN ABOVE ARE 1:1 SCALE AND CAN BE USED TO MATCH BOLT AND SCREW SIZES.

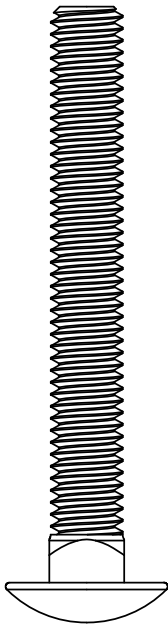

3/8" X 3"  
CARRIAGE BOLT  
QTY: 2

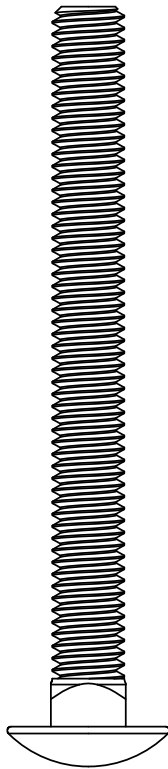

3/8" X 3-3/4"  
CARRIAGE BOLT  
QTY: 6

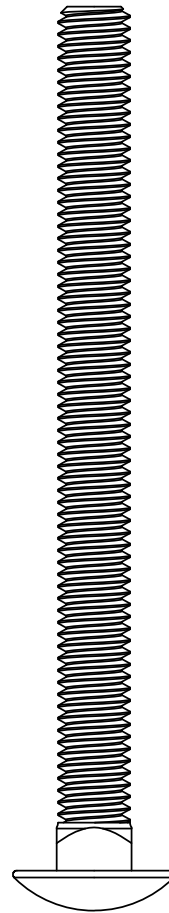

3/8" X 4-1/2"  
CARRIAGE BOLT  
QTY: 2



USE THE RULER TO THE RIGHT TO MEASURE YOUR BOLTS AND SCREWS. PICTURE VIEWS SHOWN ABOVE ARE 1:1 SCALE AND CAN BE USED TO MATCH BOLT AND SCREW SIZES.

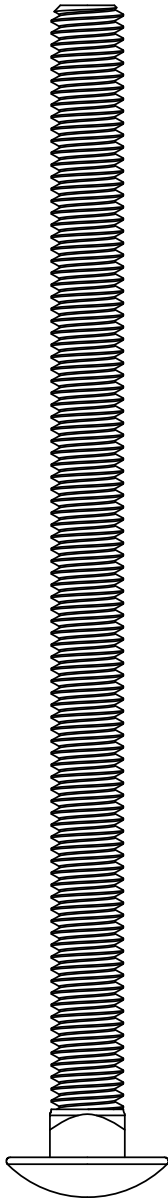

3/8" X 6"  
CARRIAGE BOLT  
QTY: 2

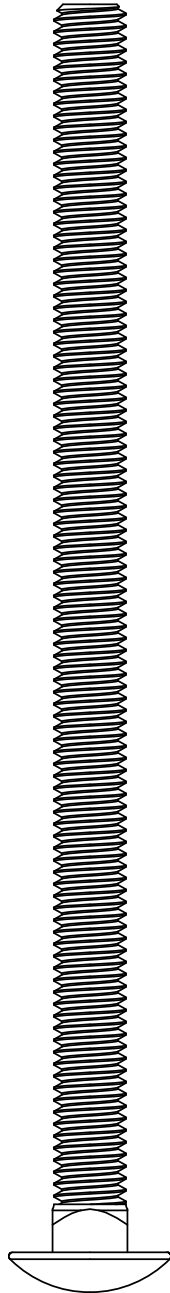

3/8" X 6-1/2"  
CARRIAGE BOLT  
QTY: 14

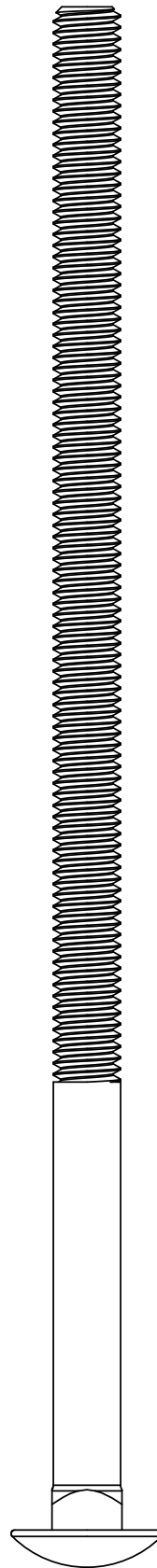

3/8" X 8-1/2"  
CARRIAGE BOLT  
QTY: 1

9  
8  
7  
6  
5  
4  
3  
2  
1

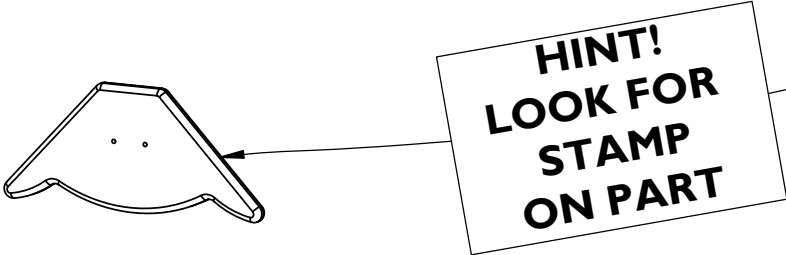
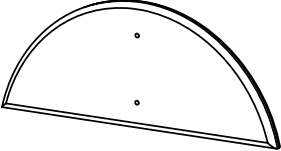
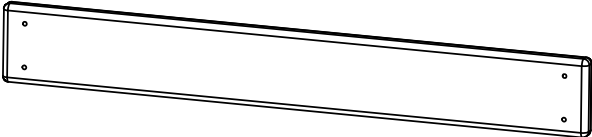
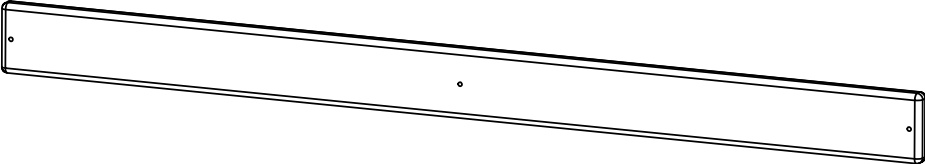
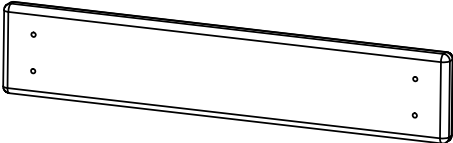
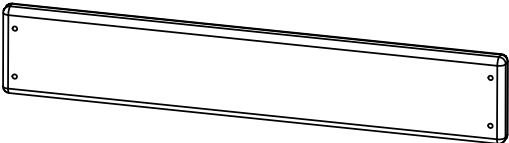
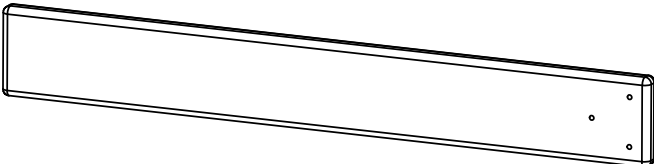

USE THE RULER TO THE RIGHT TO MEASURE YOUR BOLTS AND SCREWS. PICTURE VIEWS SHOWN ABOVE ARE 1:1 SCALE AND CAN BE USED TO MATCH BOLT AND SCREW SIZES.

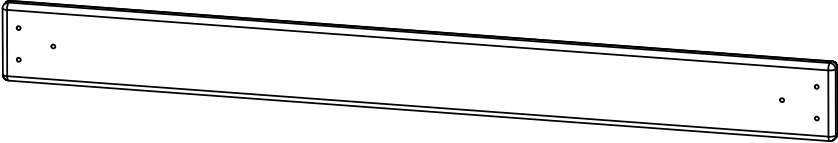
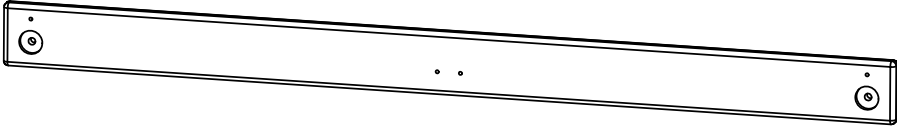
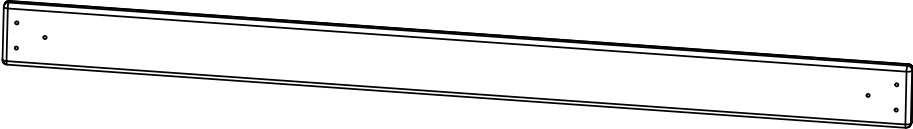
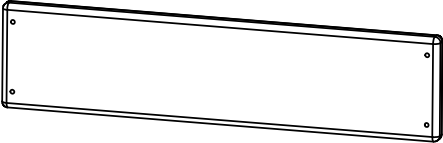
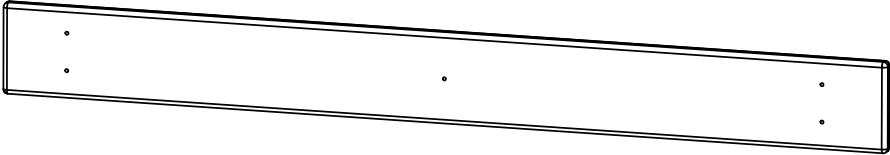
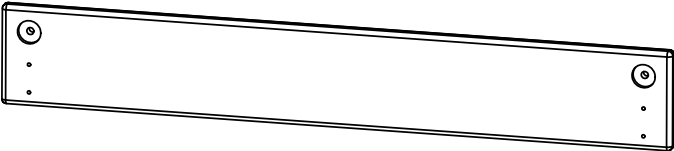
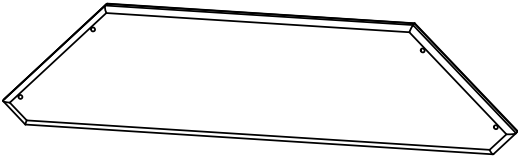

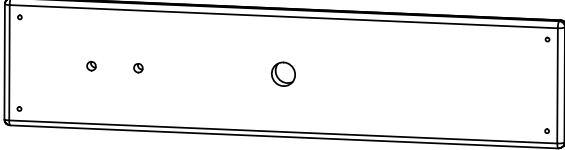
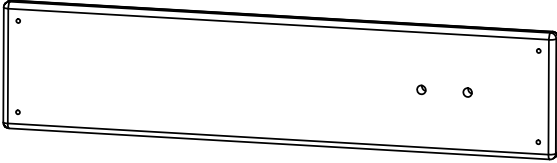
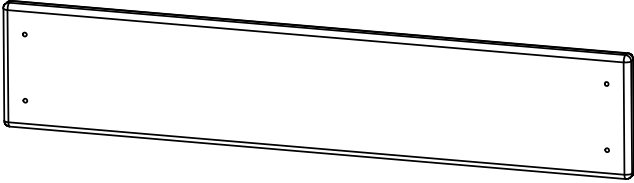
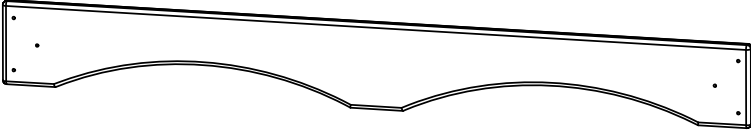
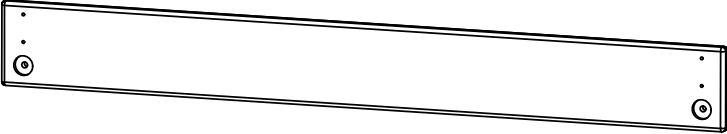
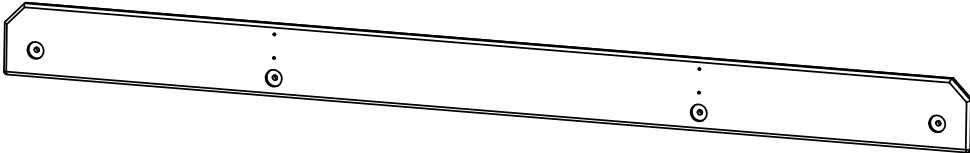
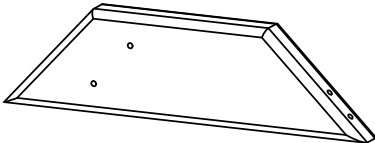
2450	PICTURE	STAMPED ID & DESCRIPTION	QTY.
		<b>2450A</b> ROOF PEAK SUPPORT 5/8" X 5-3/8" X 12.528"	2
		<b>2450B</b> SUN 5/8" X 5-3/8" X 13-5/8"	2
		<b>2450C</b> PANEL SLAT 3/4" X 3-3/8" X 25-3/4"	1
		<b>2450D</b> DECK SPACER 3/4" X 3" X 41-7/8"	2
		<b>2450E</b> TIC TAC TOE MOUNT 3/4" X 3-3/8" X 17-1/2"	2
		<b>2450F</b> WALL PANEL BOARD 1 3/4" X 3-3/8" X 19"	2
		<b>2450G</b> BOTTOM PANEL BOARD 3/4" X 3-3/8" X 25-11/16"	1

2450	PICTURE	STAMPED ID & DESCRIPTION	QTY.
		<b>2450H</b> PANEL SUPPORT 3/4" X 3-3/8" X 36"	4
		<b>2450I</b> FRONT FACE BOARD 3/4" X 3-3/8" X 48"	2
		<b>2450J</b> PANEL BOARD 3/4" X 3-3/8" X 48"	2
		<b>2450K</b> WALL PANEL BOARD 2 3/4" X 4-1/2" X 19"	2
		<b>2450L</b> DECK BOARD 3/4" X 4-7/8" X 48"	6
		<b>2450M</b> END SANDBOX BOARD 3/4" X 5-3/8" X 36"	1
		<b>2450N</b> SANDBOX SEAT 3/4" X 5-3/8" X 22"	2

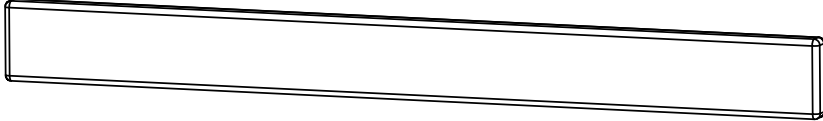
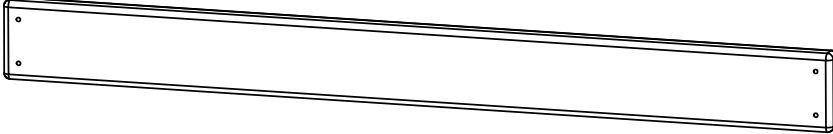

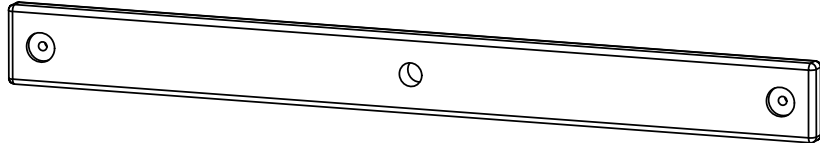
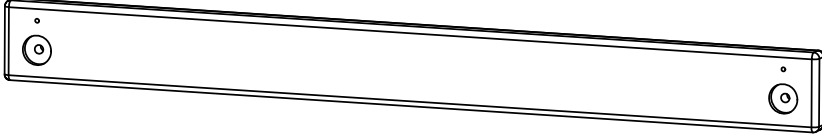
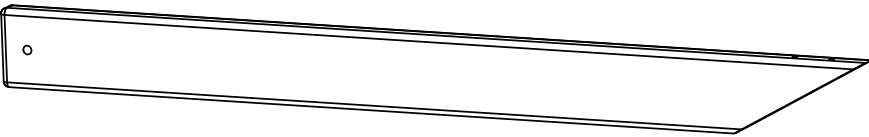
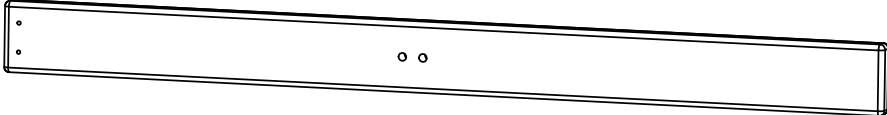

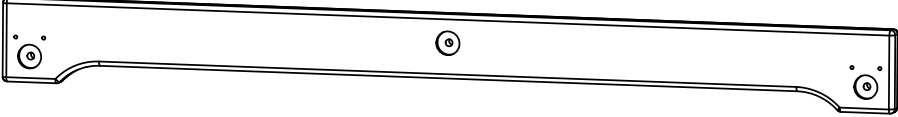
2450	PICTURE	STAMPED ID & DESCRIPTION	QTY.
		<b>2450O</b> ROCK WALL BOARD BOTTOM 3/4" X 5-3/8" X 23-7/8"	1
		<b>2450P</b> ROCK WALL BOARD 3/4" X 5-3/8" X 23-7/8"	5
		<b>2450Q</b> PANEL SLAT 3/4" X 5-3/8" X 27-1/2"	10
		<b>2450R</b> ARCH FACE BOARD 3/4" X 5-3/8" X 48"	1
		<b>2450S</b> SANDBOX BOARD 3/4" X 5-3/8" X 48"	2
		<b>2450T</b> END SANDBOX BOARD 3/4" X 5-3/8" X 75"	1
		<b>2450U</b> ANGLE SUPPORT 1" X 3-3/8" X 13"	8

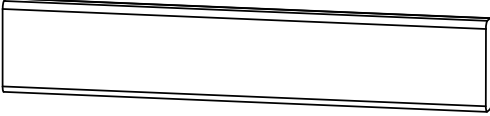
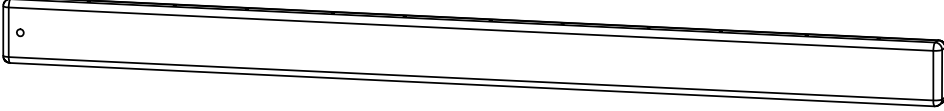
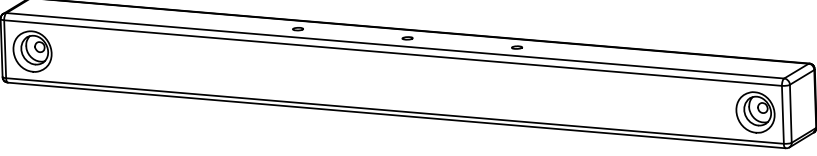
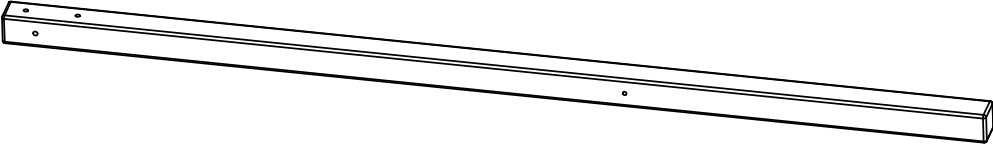
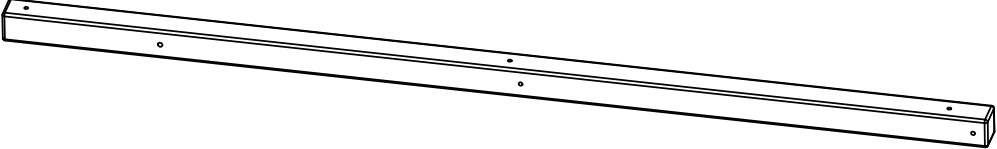

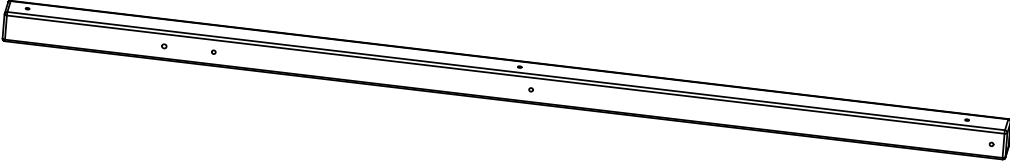
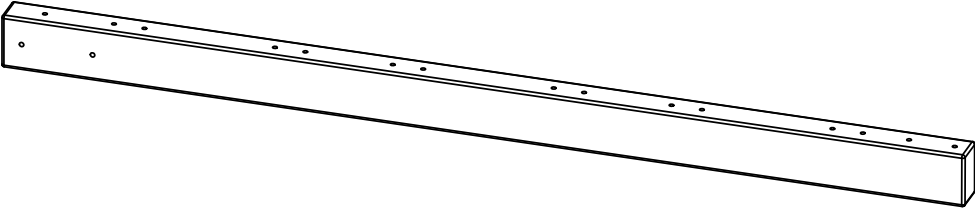

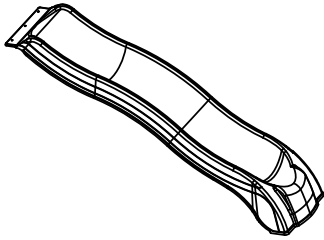
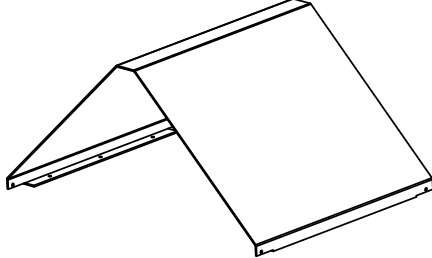
2450	PICTURE	STAMPED ID & DESCRIPTION	QTY.
		<b>2450V</b> STRINGER 1" X 3-3/8" X 36"	1
		<b>2450W</b> CENTER TARP BOARD 1" X 3-3/8" X 36"	1
		<b>2450X</b> END BOARD 1" X 3-3/8" X 36"	2
		<b>2450Y</b> ROCK WALL ROPE SUPPORT 1" X 3-3/8" X 36"	1
		<b>2450Z</b> DECK SUPPORT 1" X 3-3/8" X 36"	2
		<b>2450AA</b> FORT SIDE SUPPORT 1" X 3-3/8" X 40"	2
		<b>2450AB</b> TARP CENTER POST 1" X 3-3/8" X 43"	2

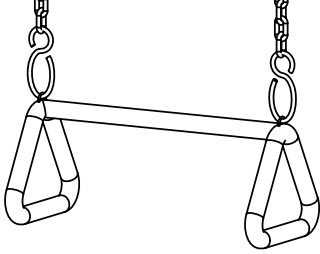
2450	PICTURE	STAMPED ID & DESCRIPTION	QTY.
		<p><b>2450AC</b>  REAR TARP  SUPPORT  1" X 4-3/8" X 48"</p>	2
		<p><b>2450AD</b>  CROSS MEMBER  1" X 3-3/8" X 68-1/2"</p>	1
		<p><b>2450AE</b>  SLIDE BLOCKS  1" X 3-3/8" X 18"</p>	2
		<p><b>2450AF</b>  ROCK WALL SIDE  1-3/8" X 3-3/8" X 50-1/2"</p>	2
		<p><b>2450AG</b>  SWING BEAM  MOUNT  3" X 3" X 36"</p>	1
		<p><b>2450AH</b>  SWING LEG  3" X 3" X 95"</p>	2
		<p><b>2450AI</b>  CORNER POST 1  3" X 3" X 95"</p>	2

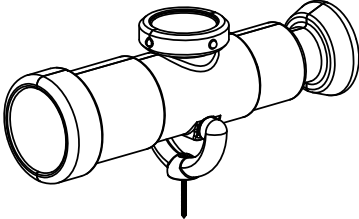
2450	PICTURE	STAMPED ID & DESCRIPTION	QTY.
		<p><b>2450AJ</b> CORNER POST 2 3" X 3" X 95"</p>	2
		<p><b>2450AK</b> SWING BEAM 3-3/8" X 5-3/8" X 95"</p>	1
			25

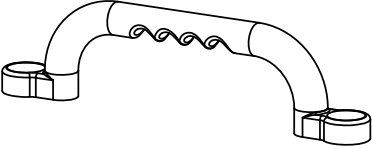
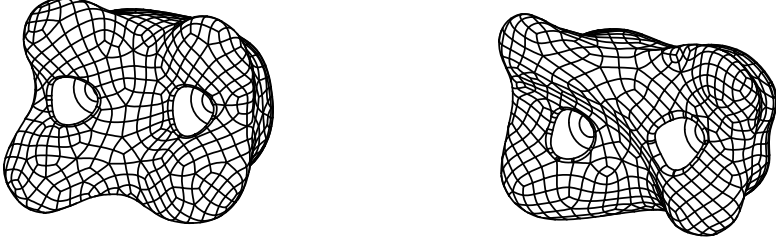
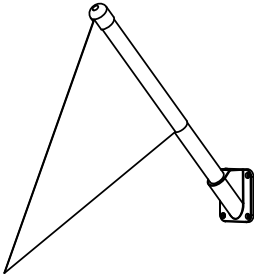
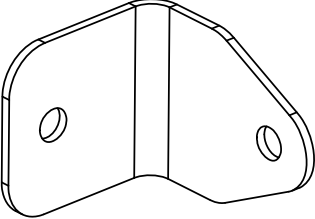
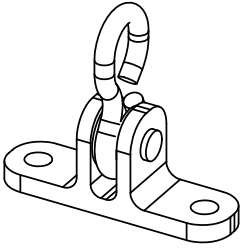
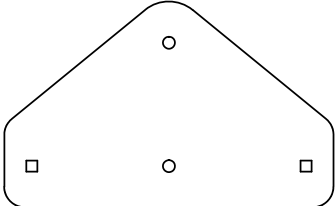
	PICTURE	DESCRIPTION	QTY.
<b>2450</b>		WAVE SLIDE <b>03-0016-G</b>	1
		36" X 72-3/4" TARP <b>05-0014</b>	1
		SWING BELT WITH CHAINS <b>04-0002</b>	2
		TRAPEZE SWING WITH CHAINS <b>04-0006</b>	1
		PERISCOPE <b>07-0002</b>	1
		TIC TAC TOE (UNASSEMBLED) <b>01-0010</b>	1
		TELESCOPE W/ COMPASS <b>07-0037-G</b> <b>WS 4610</b>	1

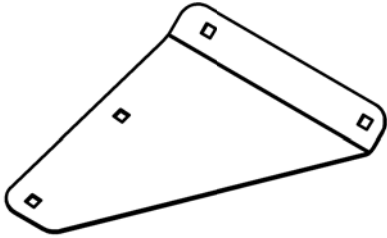
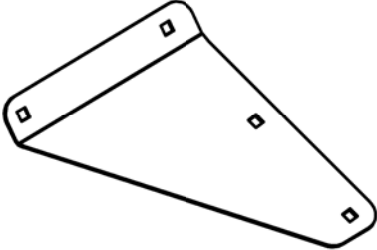
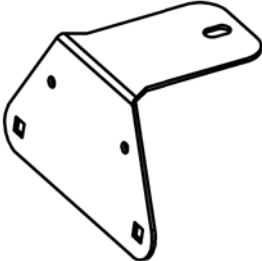
PICTURE	DESCRIPTION	QTY.
	PLASTIC SAFETY HANDLES (PAIR) <b>07-0005</b>	1 pr
	ROCK WALL ROCKS (COLOR & SIZE MAY VARY) <b>07-0038-G/Y</b> <b>WS 4545</b>	6 rocks
	FLAG KIT (PAIR) <b>09-1014</b>	1 pr
	90° BRACKET <b>11-9010</b>	2
	IRON DUCTILE SWING HANGER <b>11-4024</b>	6
<p>(3/4" DIAMETER ROPE NOT SHOWN)</p>	13 FT. ROPE-ROPE LADDER <b>10-1008</b>	1 PC.
	SWING BEAM PLATE <b>11-5025</b> <b>2411</b>	1

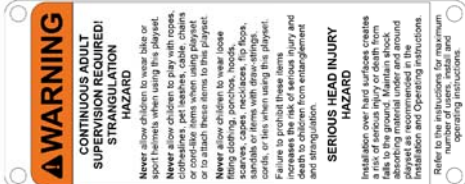
PICTURE	DESCRIPTION	QTY.
	SWING BEAM ANGLED PLATE RIGHT <b>11-5019</b> <b>2447</b>	1
	SWING BEAM ANGLED PLATE LEFT <b>11-5020</b> <b>2448</b>	1
	SWING BEAM 90° PLATE <b>11-5021</b> <b>2449</b>	1
	PLASTIC GROUND STAKES (PAIR) <b>07-0016-P</b>	3 pr
(NOT SHOWN)	LOGO PLATE <b>11-4018</b>	1
(NOT SHOWN)	2450 HARDWARE KIT 11-0098	1
	SAFETY WARNING PLATE <b>11-5023</b> <b>SA 4294</b>	1

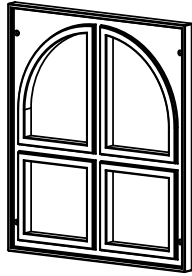
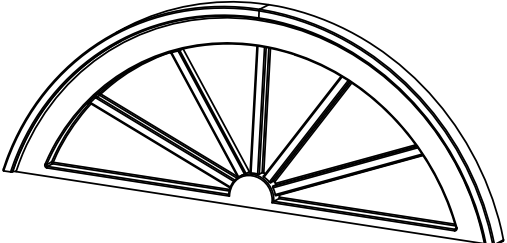
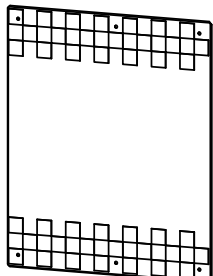
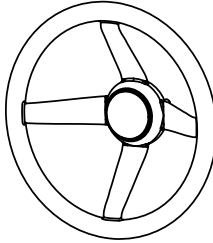
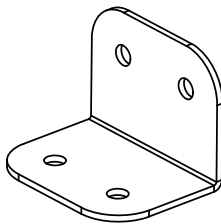
PICTURE	DESCRIPTION	QTY.
	<p>DORMER WINDOW <b>07-0029-G</b></p>	<p>2</p>
	<p>CROWN <b>07-0019</b></p>	<p>1</p>
	<p>CHALKBOARD <b>07-0018</b></p>	<p>1</p>
	<p>PRODUCT MAY VARY FROM IMAGE SHOWN</p> <p>STEERING WHEEL <b>07-0004</b></p>	<p>1</p>
	<p>PANEL BRACKET <b>11-5026</b> <b>PF 4969</b></p>	<p>1</p>
		<p>29</p>

# STEP 1: CORNER POST LAYOUT

1: LAY OUT EACH CORNER POSTS IN THE AREA YOU INTEND ON BUILDING THE PLAYSET.

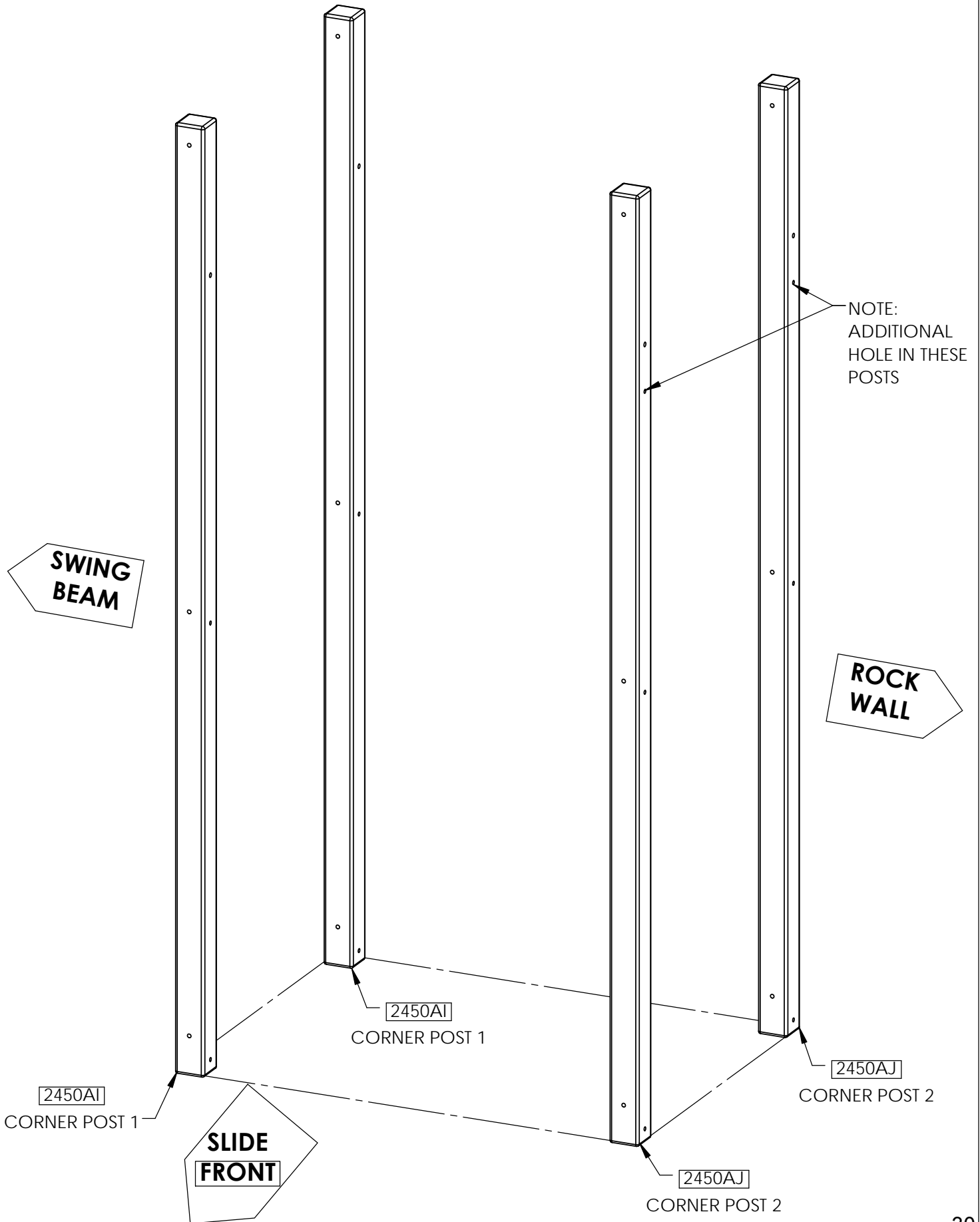



# STEP 2: INSERTING T-NUTS INTO CORNER POSTS

1: USE A HAMMER TO SEAT THE T-NUTS AFTER INSERTING THEM INTO THE HOLES SHOWN IN THE DIAGRAM BELOW.

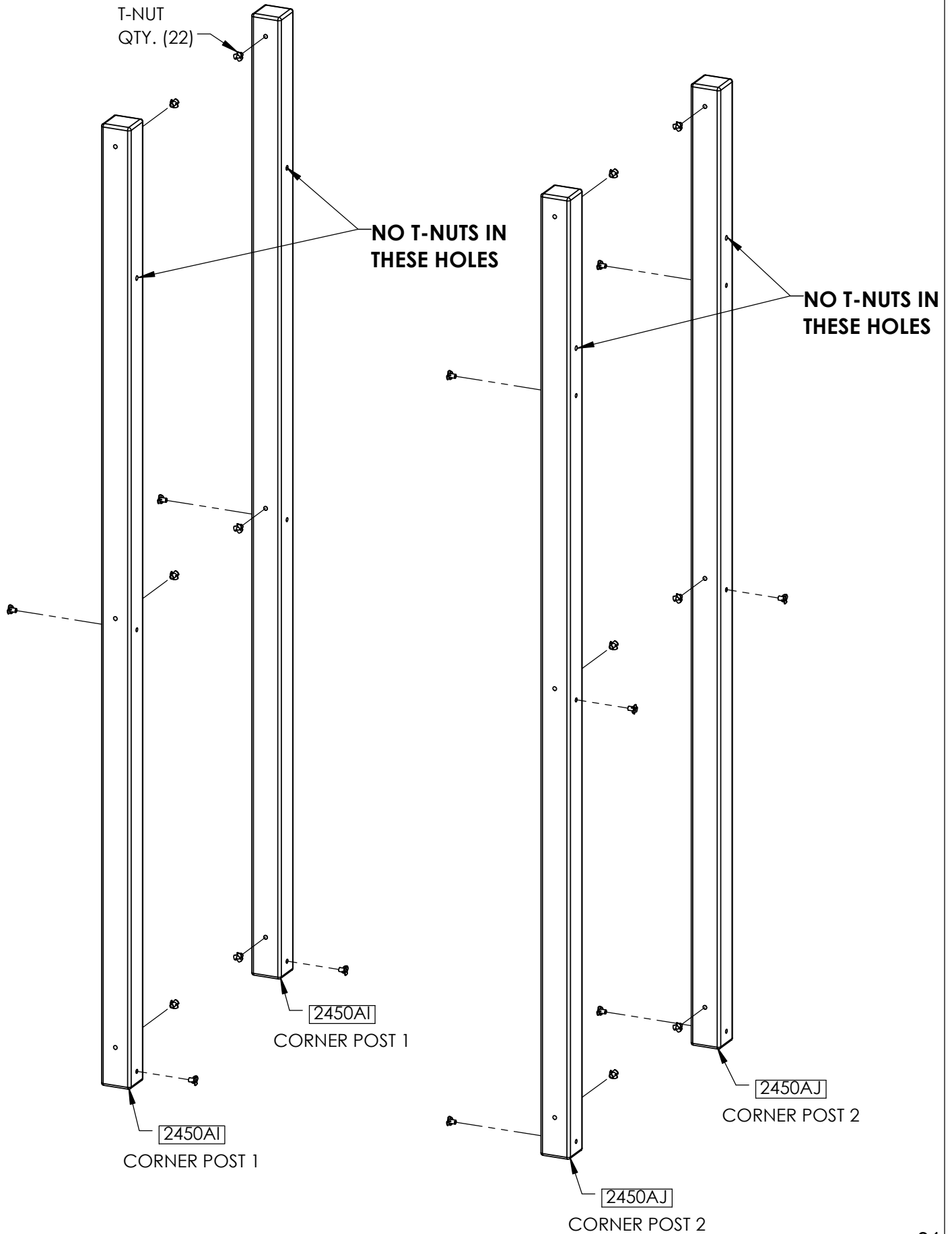

# STEP 3: SANDBOX BOARD, DECK SUPPORT & ROCK WALL ROPE SUPPORT

1: INSTALL BOARDS AS SHOWN BELOW.

\* NOTE POSITION OF COUNTERBORE HOLES.

\* NOTE THE DIFFERENT BOLT LENGTHS USED BETWEEN THE TOP & BOTTOM BOARDS.

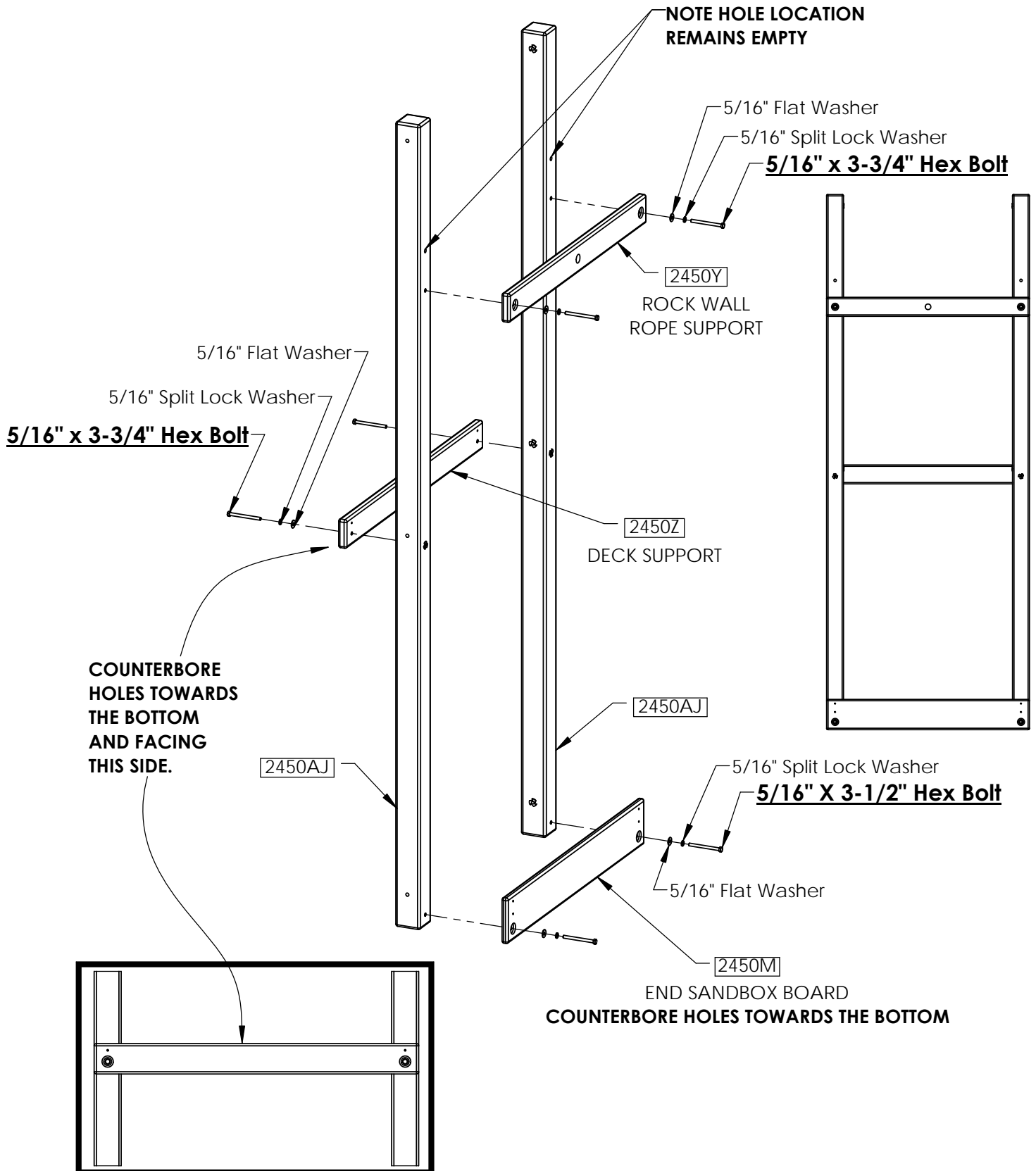

# STEP 4: SWING BEAM MOUNT

1: INSTALL THE SWING PLATE AS SHOWN BELOW.

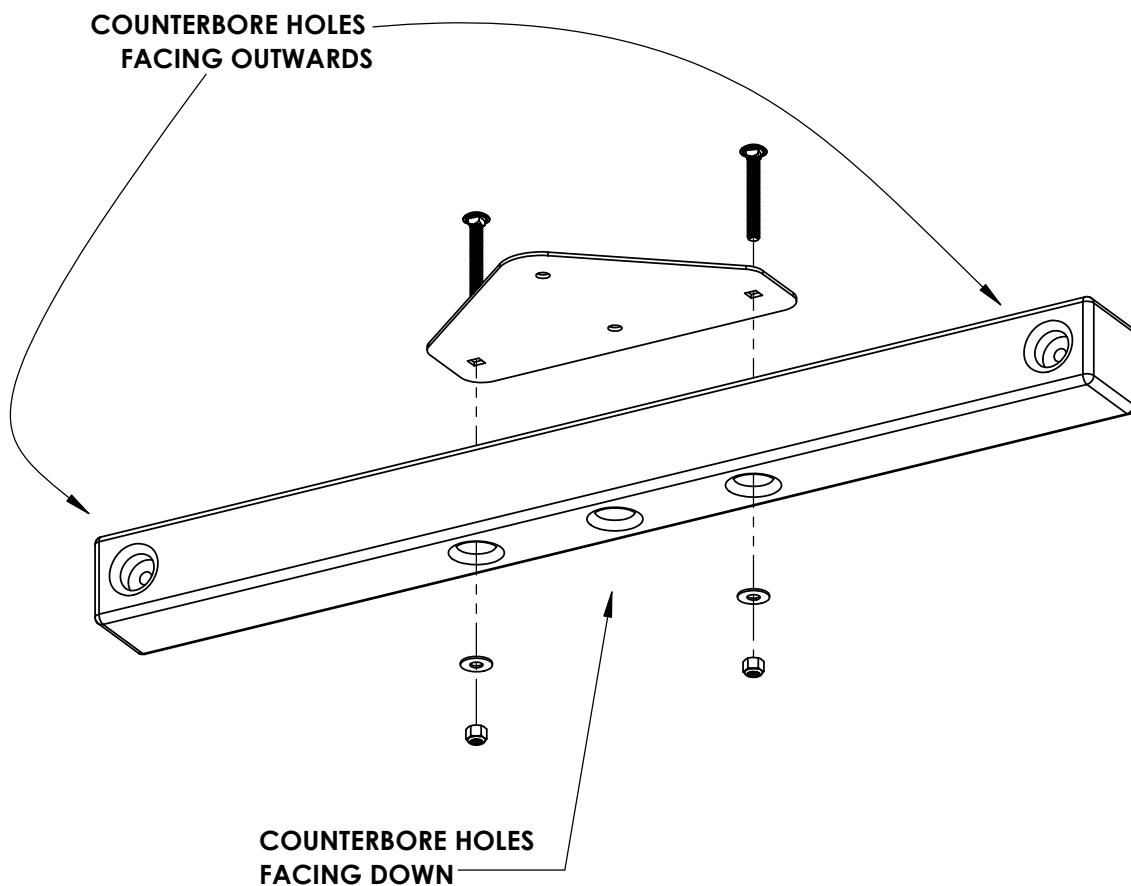
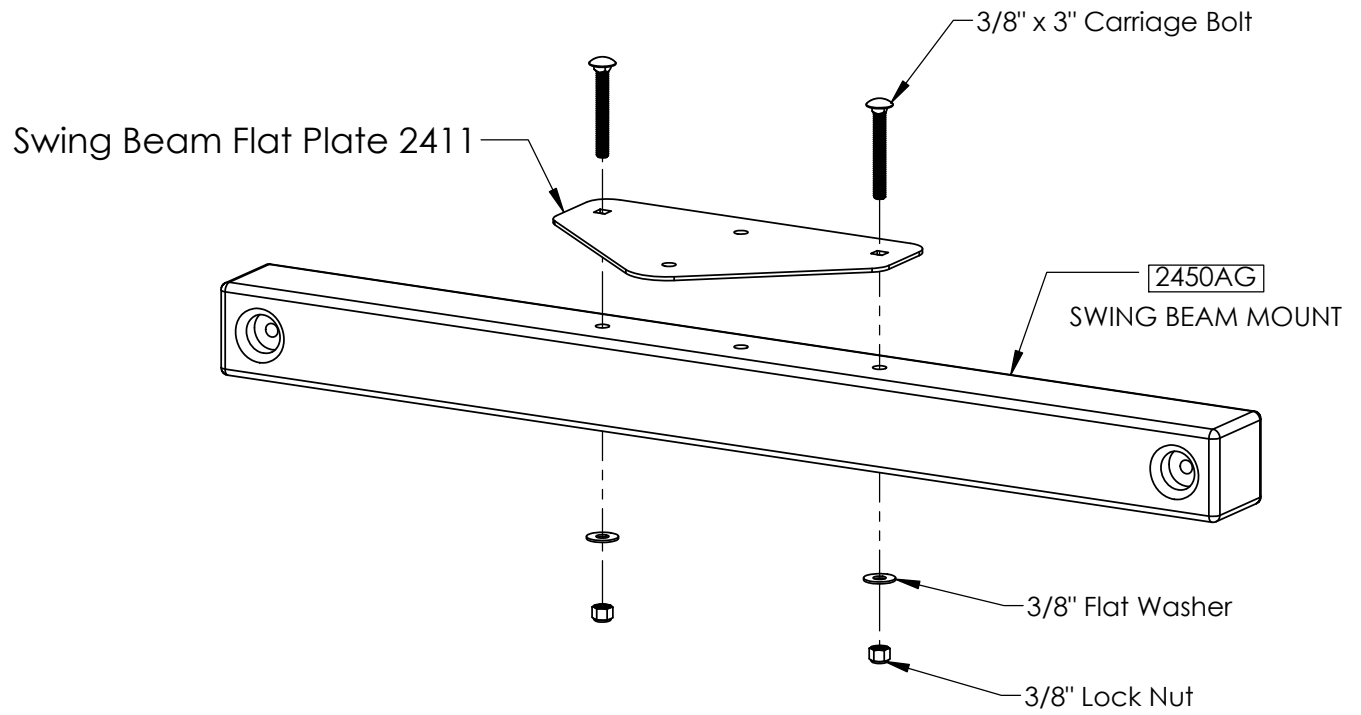

# STEP 5: END SANDBOX BOARD, DECK SUPPORT & SWING BEAM MOUNT

1: INSTALL BOARDS AS SHOWN BELOW.

**\* NOTE POSITION OF COUNTERBORE HOLES.**

**\* NOTE THE DIFFERENT BOLT LENGTHS USED BETWEEN THE TOP & BOTTOM BOARDS.**

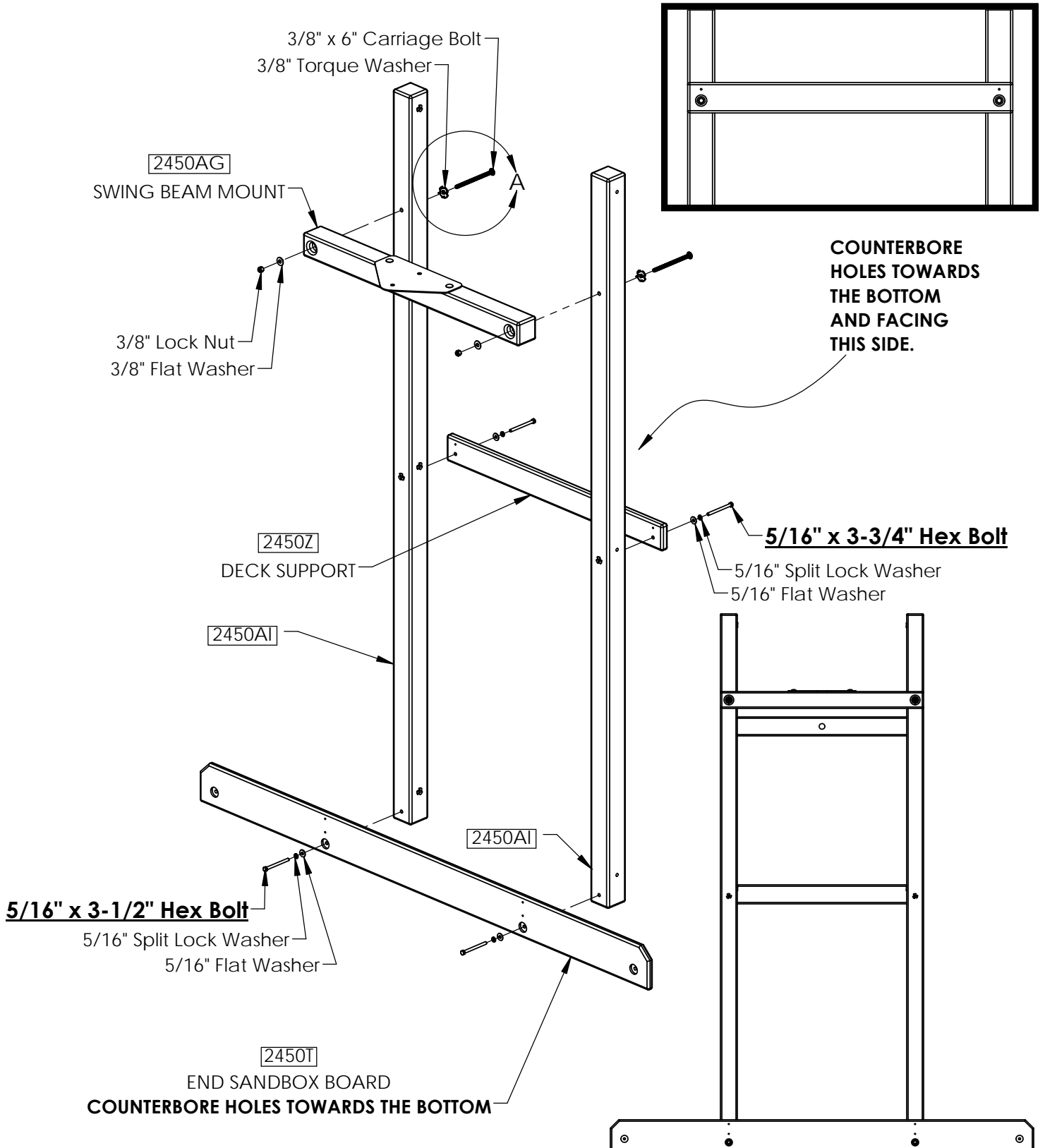

# STEP 6: FRONT FACE BOARDS

1: INSTALL BOARDS AS SHOWN BELOW.

**NOTE POSITION OF COUNTERBORE HOLES.**

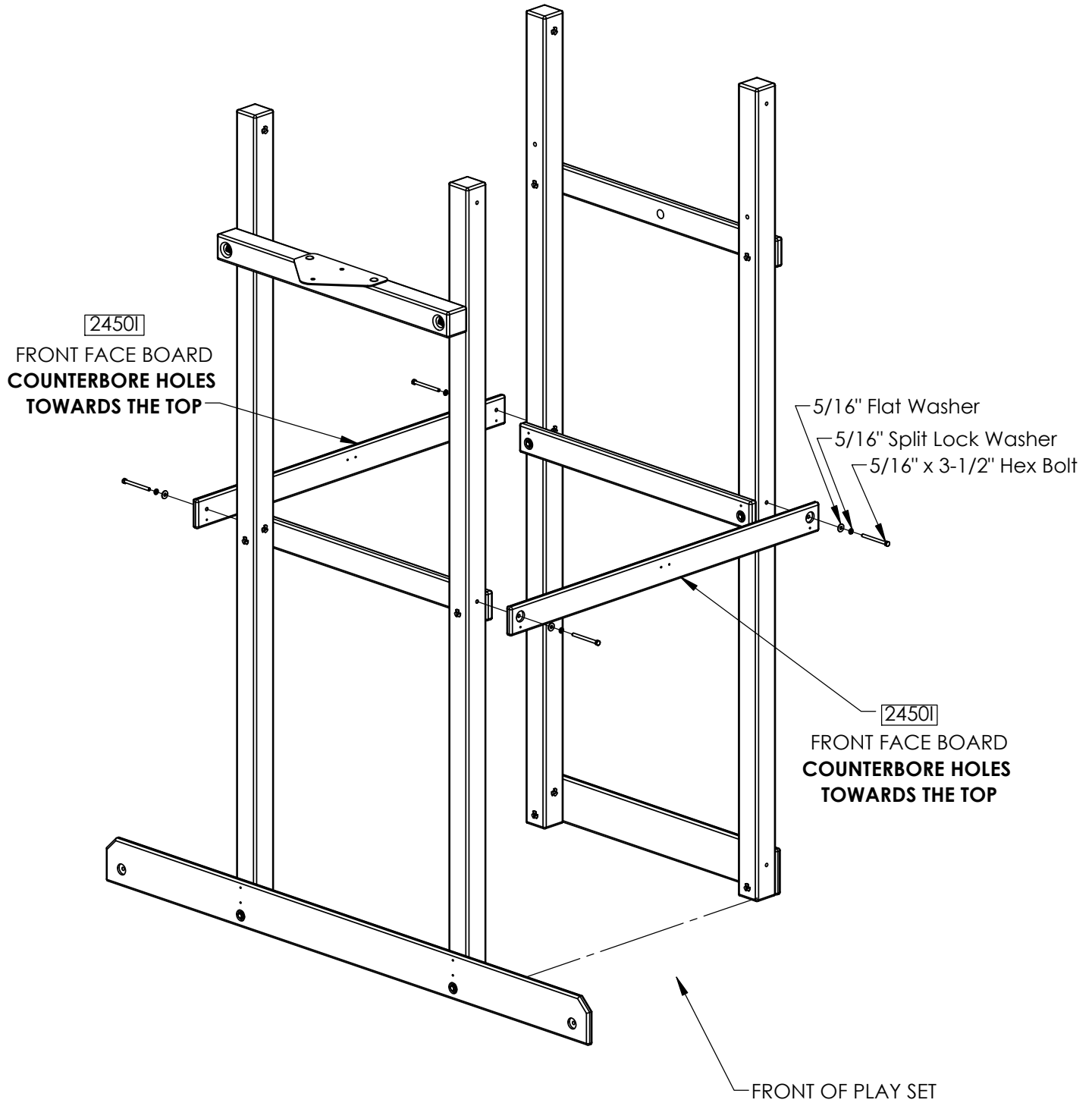

# STEP 7: REAR TARP SUPPORTS & SANDBOX BOARDS

1: INSTALL BOARDS AS SHOWN BELOW.

- \* NOTE POSITION OF COUNTERBORE HOLES.
- \* NOTE THE DIFFERENT BOLT LENGTHS USED BETWEEN THE TOP & BOTTOM BOARDS.

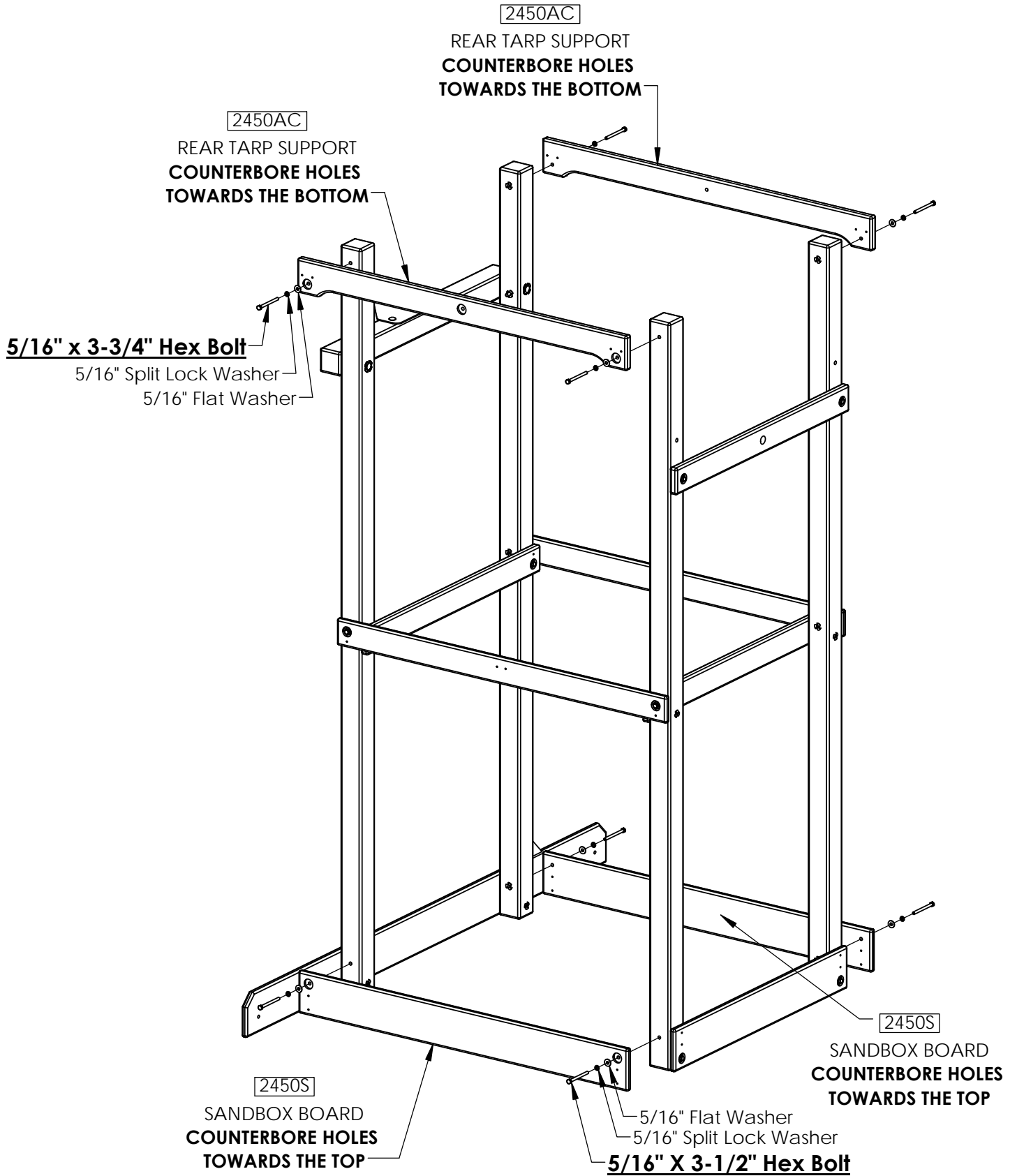

# STEP 8: FORT SIDE SUPPORTS

1: INSTALL BOARDS AS SHOWN.

**NOTE: ENSURE THAT THE TWO FORT SIDE SUPPORTS ARE ATTACHED PROPERLY TO THE SANDBOX BOARD AND ALL PARTS ARE LEVEL AND SQUARE BEFORE SECURING THEM TO THE CORNER POSTS.**

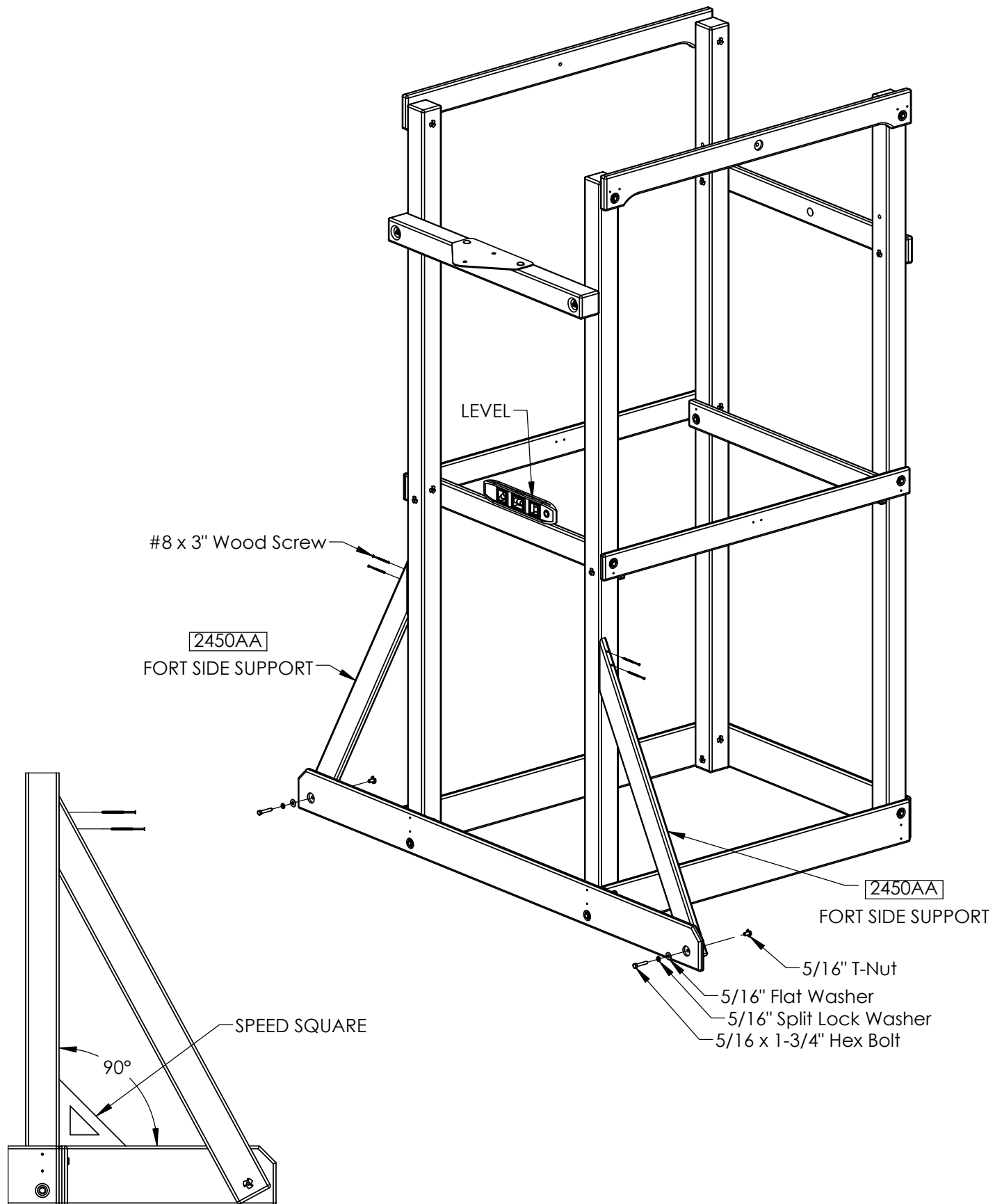

# STEP 9: LEVELING THE PLAY SET AND ADDING SCREWS

\* ENSURE ALL PARTS ARE LEVEL AND SQUARE BEFORE SECURING THEM TO THE CORNER POSTS.

\* START WITH DECK LEVEL PARTS FIRST.

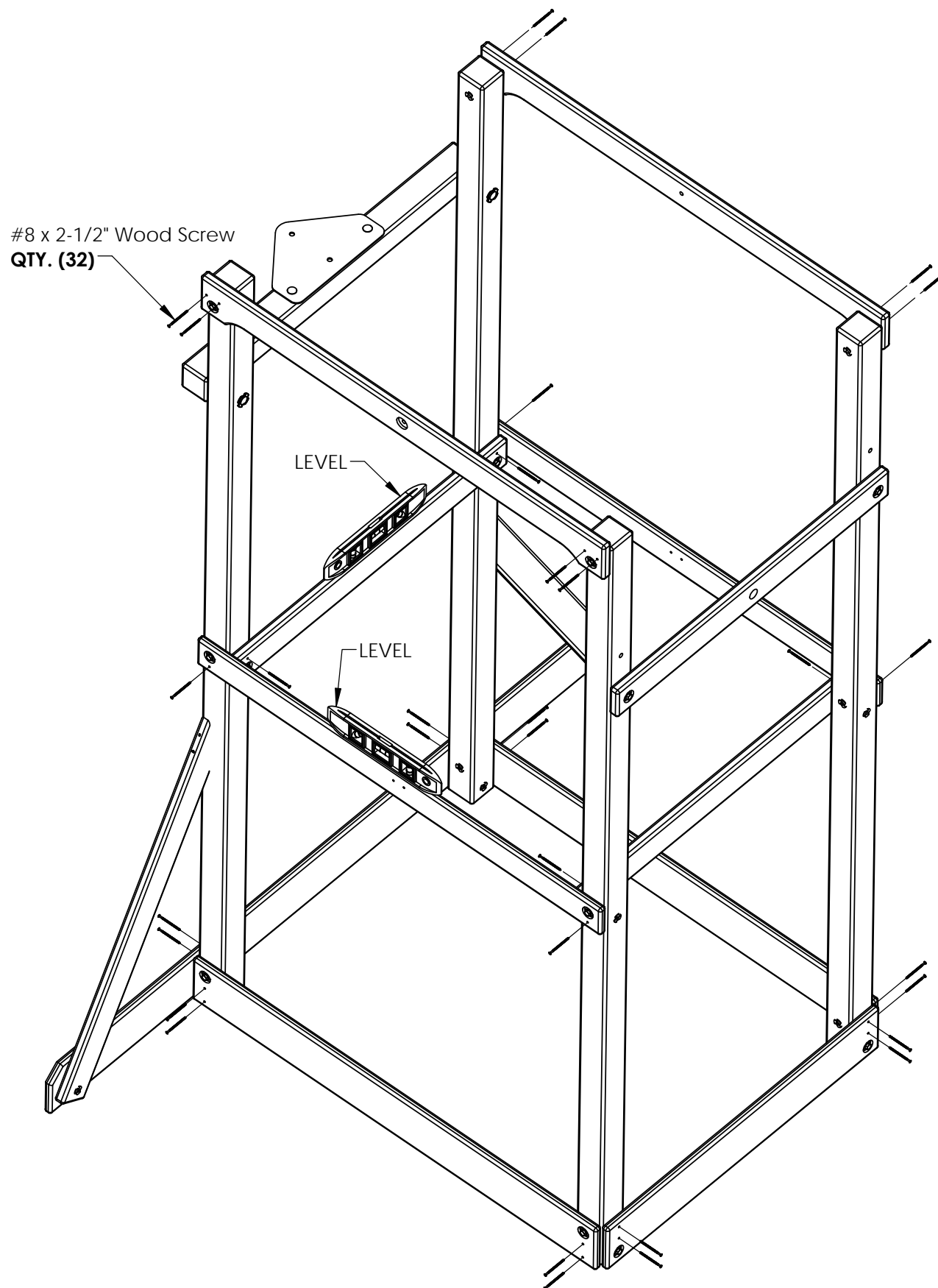



# STEP 10: DECK BOARDS

1: PLACE ALL DECK BOARDS ON DECK SUPPORTS FIRST. **MAKE SURE ALL BOARDS ARE EVENLY SPACED AND FLUSH TO THE CORNER POSTS.**

2: PLACE THE DECK SPACERS BETWEEN THE CORNER POST AND **FLUSH TO THE FRONT AND REAR FACE BOARDS.**

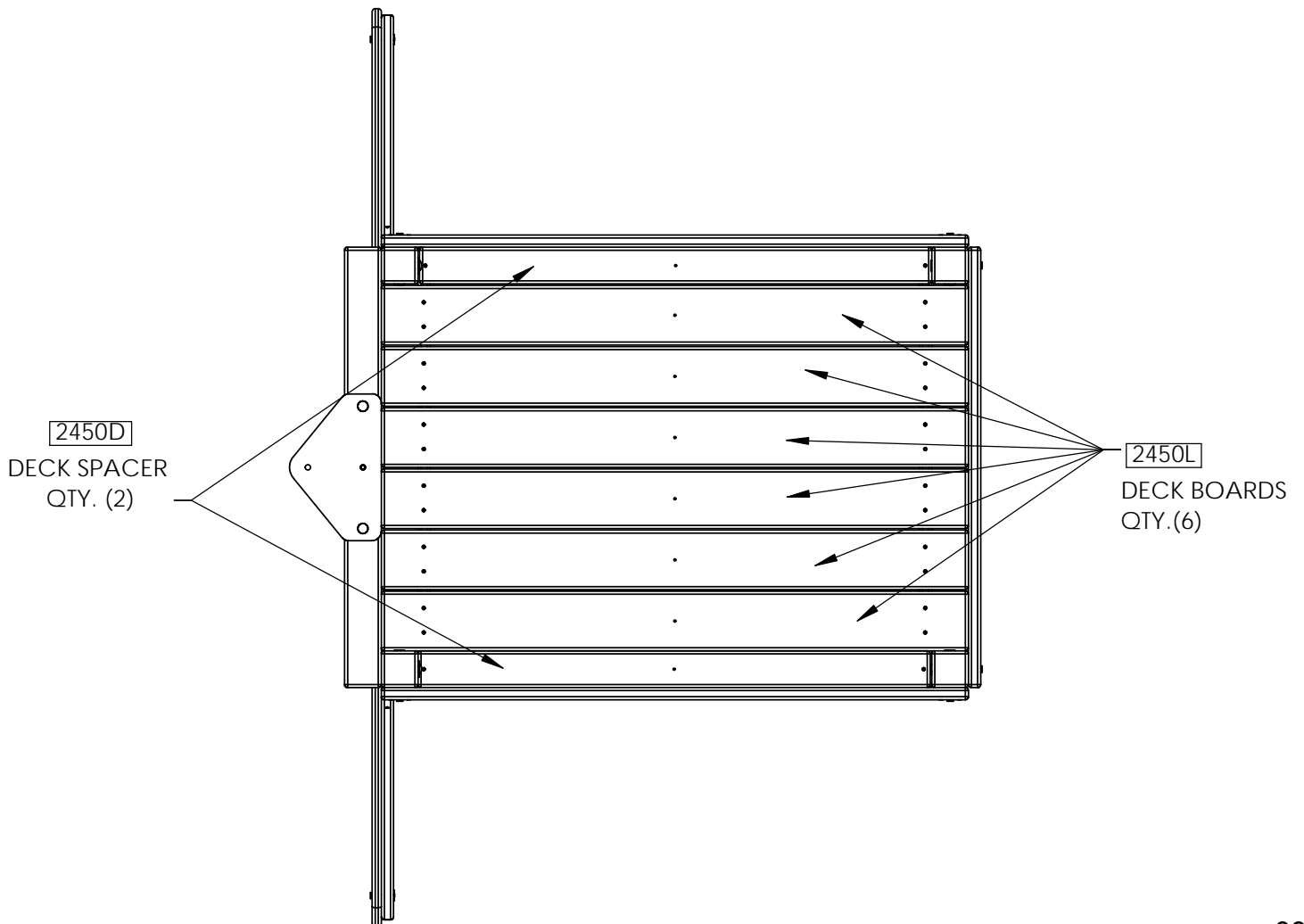
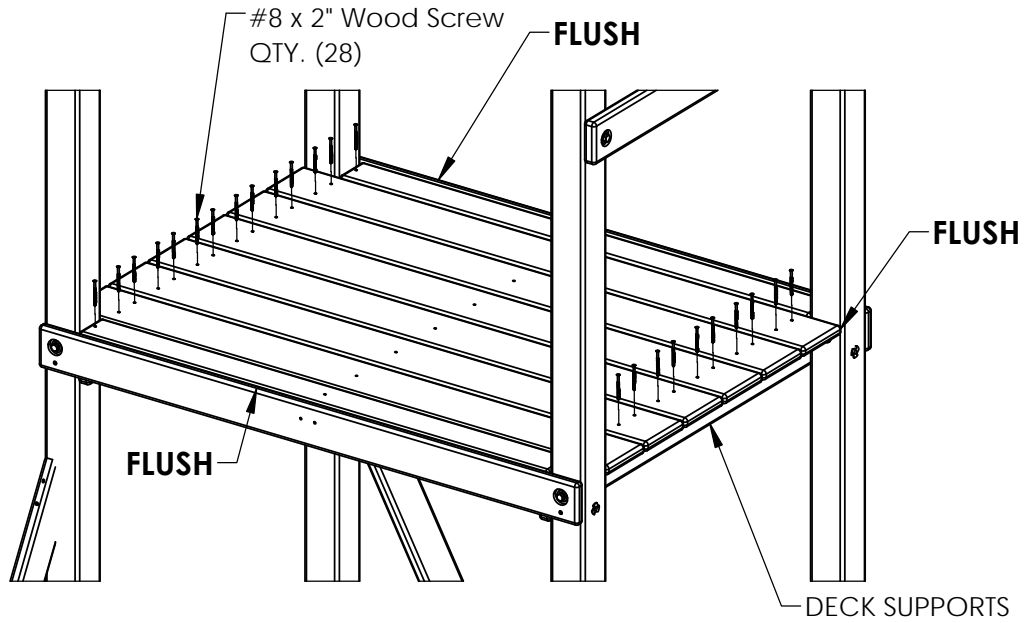

# STEP 11: DECK STRINGER

1: PLACE THE STRINGER UNDERNEATH THE CENTER OF THE DECK BOARDS.

**NOTE: USE THE HOLES AT THE CENTER OF THE FRONT FACE BOARDS AS A GUIDE TO CENTER THE STRINGER.**

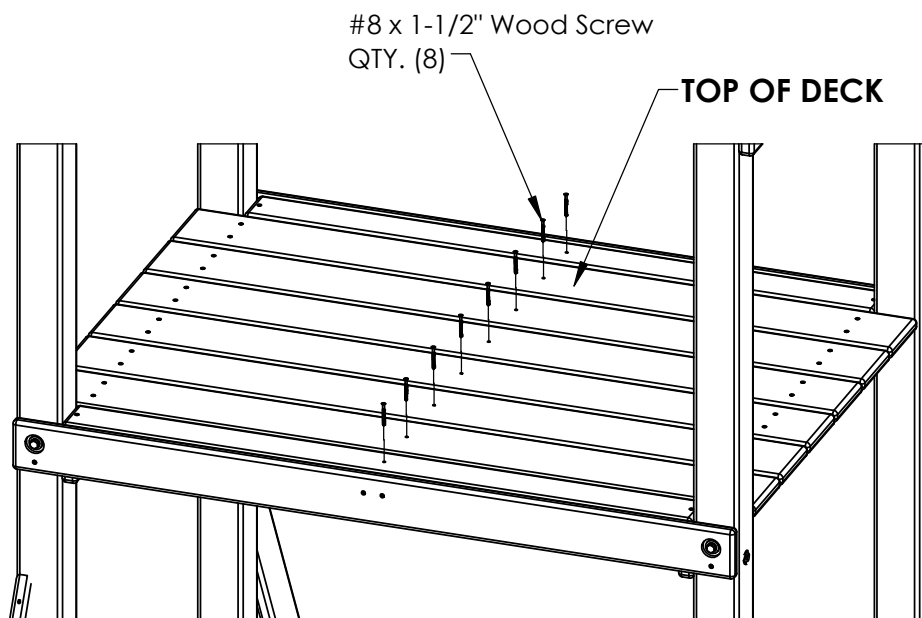
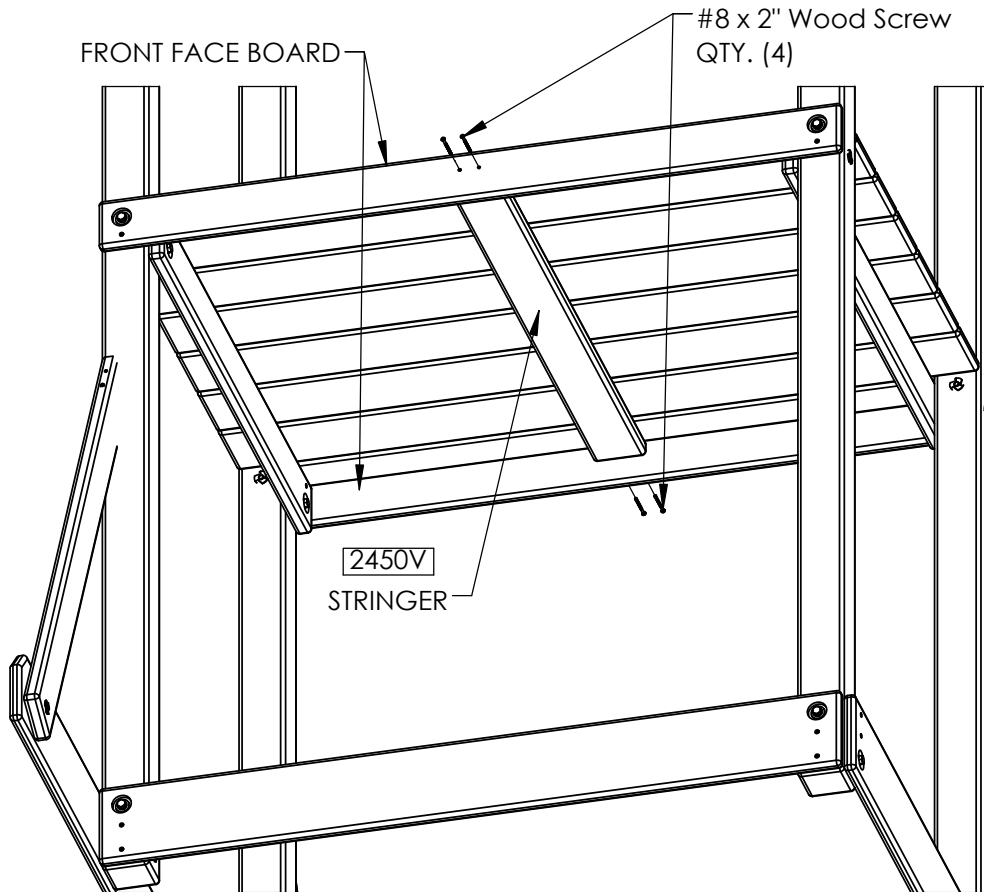

# STEP 12: ANGLE SUPPORTS

1: INSTALL BOARDS AS SHOWN BELOW.

**NOTE TWO DIFFERENT SCREW LENGTHS ARE USED FOR ANGLE SUPPORT ASSEMBLY.**

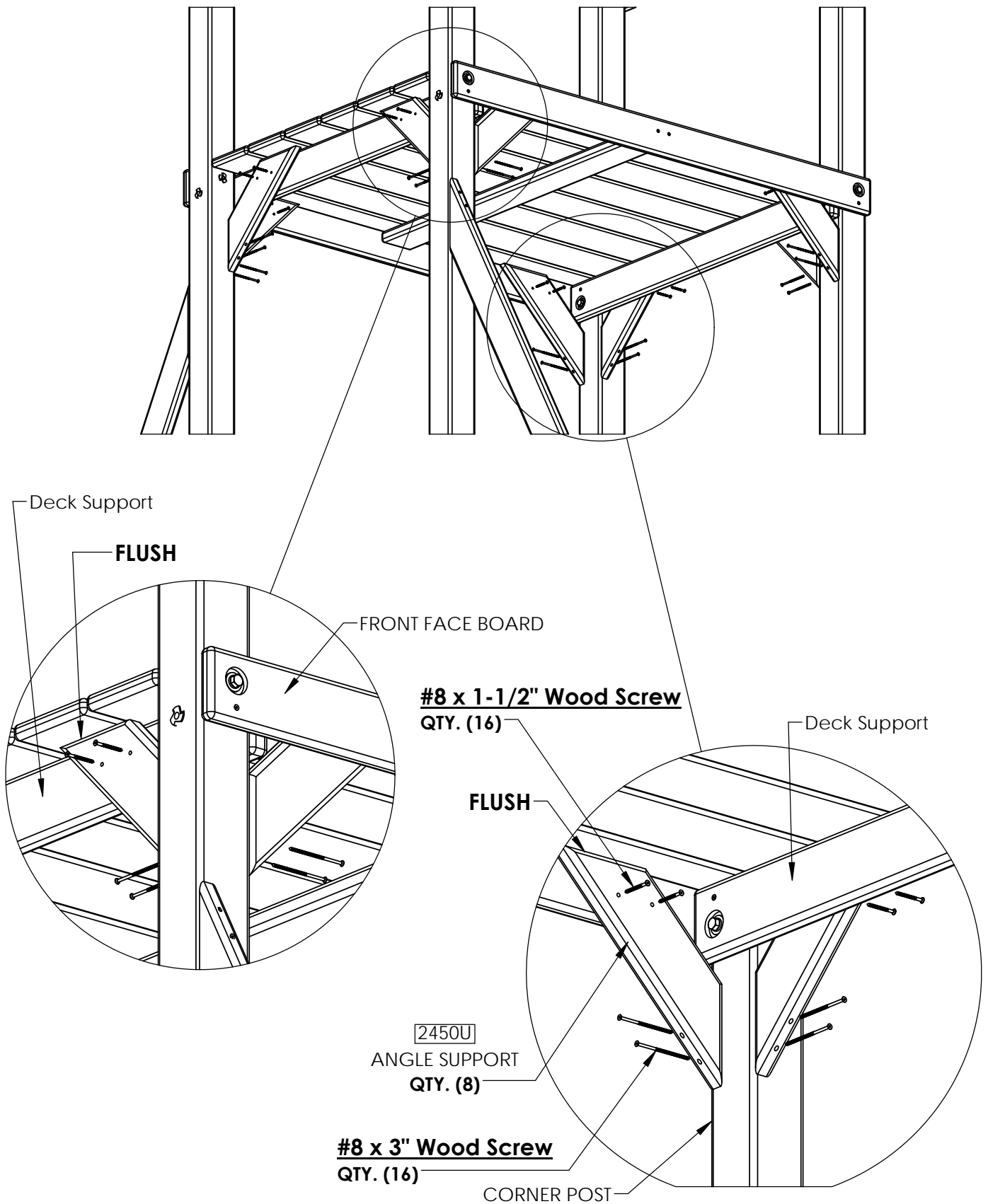

# STEP 13: PANEL BOARDS AND PANEL SUPPORTS

1: INSTALL BOARDS AS SHOWN BELOW.

**NOTE ORDER OF INSTALLATION.**

**\*\* ALL BOARDS MUST BE PARALLEL AND FLUSH TO EACH OTHER, USE DIMENSIONS AS REFERENCE \*\***

**TOPS  
FLUSH**

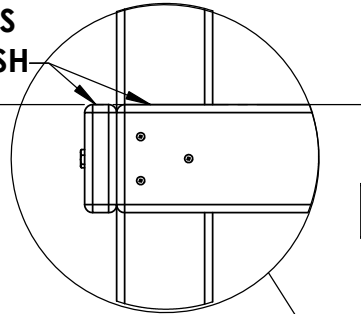

#8 X 2-1/2"  
Wood Screw  
QTY. (30)

**2450J**  
**(INSTALL SECOND)**

25  $\frac{5}{8}$ "

**2450J**  
PANEL BOARD  
**(INSTALL FIRST)**  
QTY. (2)

**FLUSH**

**TOPS  
FLUSH**

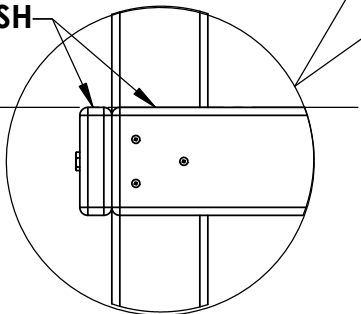

**2450H**  
PANEL SUPPORT  
**(INSTALL THIRD)**  
QTY. (3)

25  $\frac{5}{8}$ "

**2450H**

**2450H**

18  $\frac{5}{8}$ "

# STEP 14: ARCH FACE BOARD & PANEL SUPPORT

1: INSTALL BOARDS AS SHOWN BELOW.

2: ***IMPORTANT*** - USE ONLY TWO SCREWS TO TEMPORARILY INSTALL **2450H**

**\*\* ALL BOARDS MUST BE PARALLEL AND FLUSH TO EACH OTHER \*\***

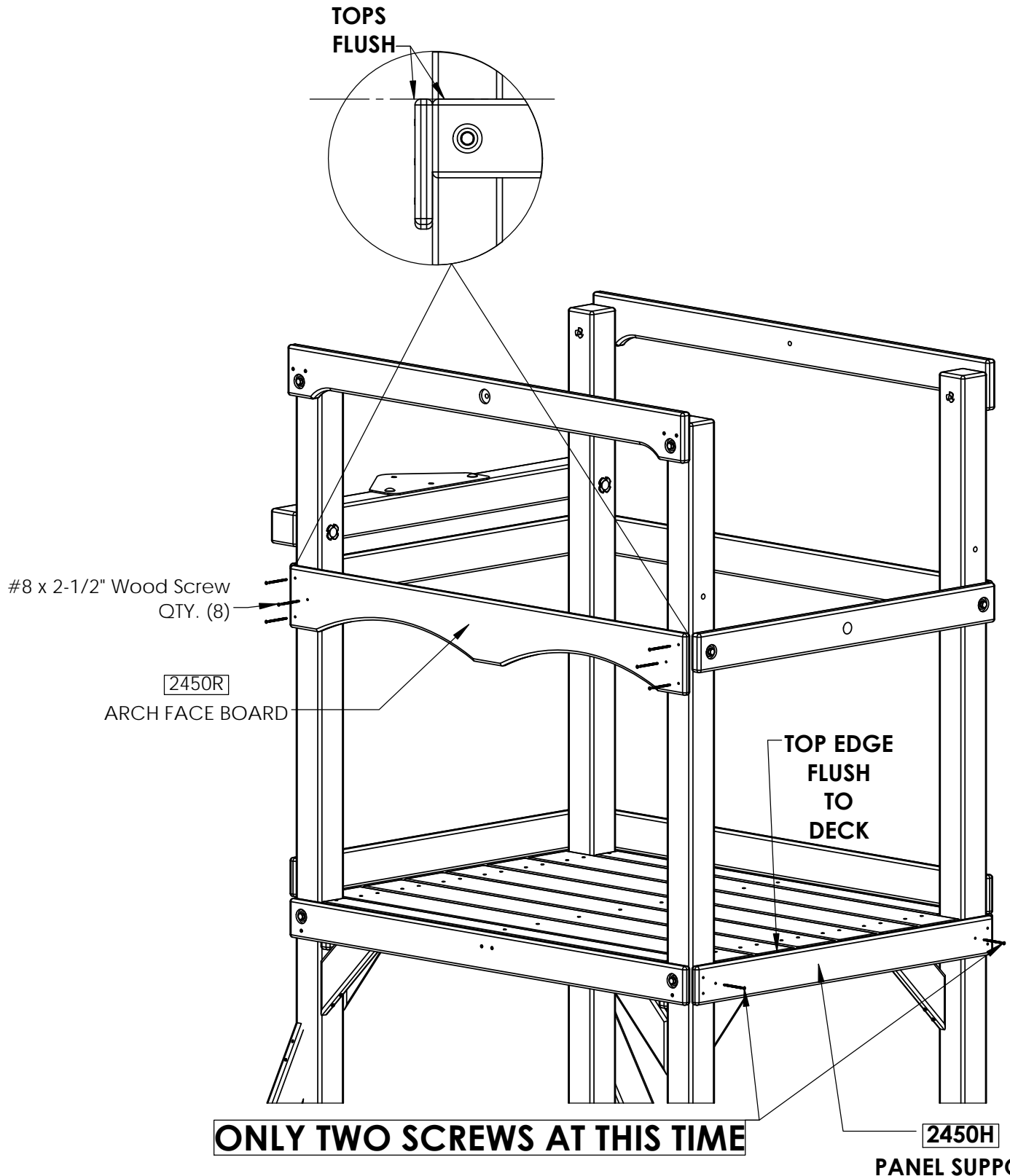

# STEP 15: ROCK WALL

1: POSITION THE ROCK WALL SIDES SO THAT THE HOLES IN THE BOARDS ARE BOTH FACING THE SAME WAY.

2: HAMMER T-NUTS INTO THE HOLES.

**\*\* DO NOT FULLY TIGHTEN THE HEX BOLTS INTO THE T-NUTS AT THIS TIME \*\***

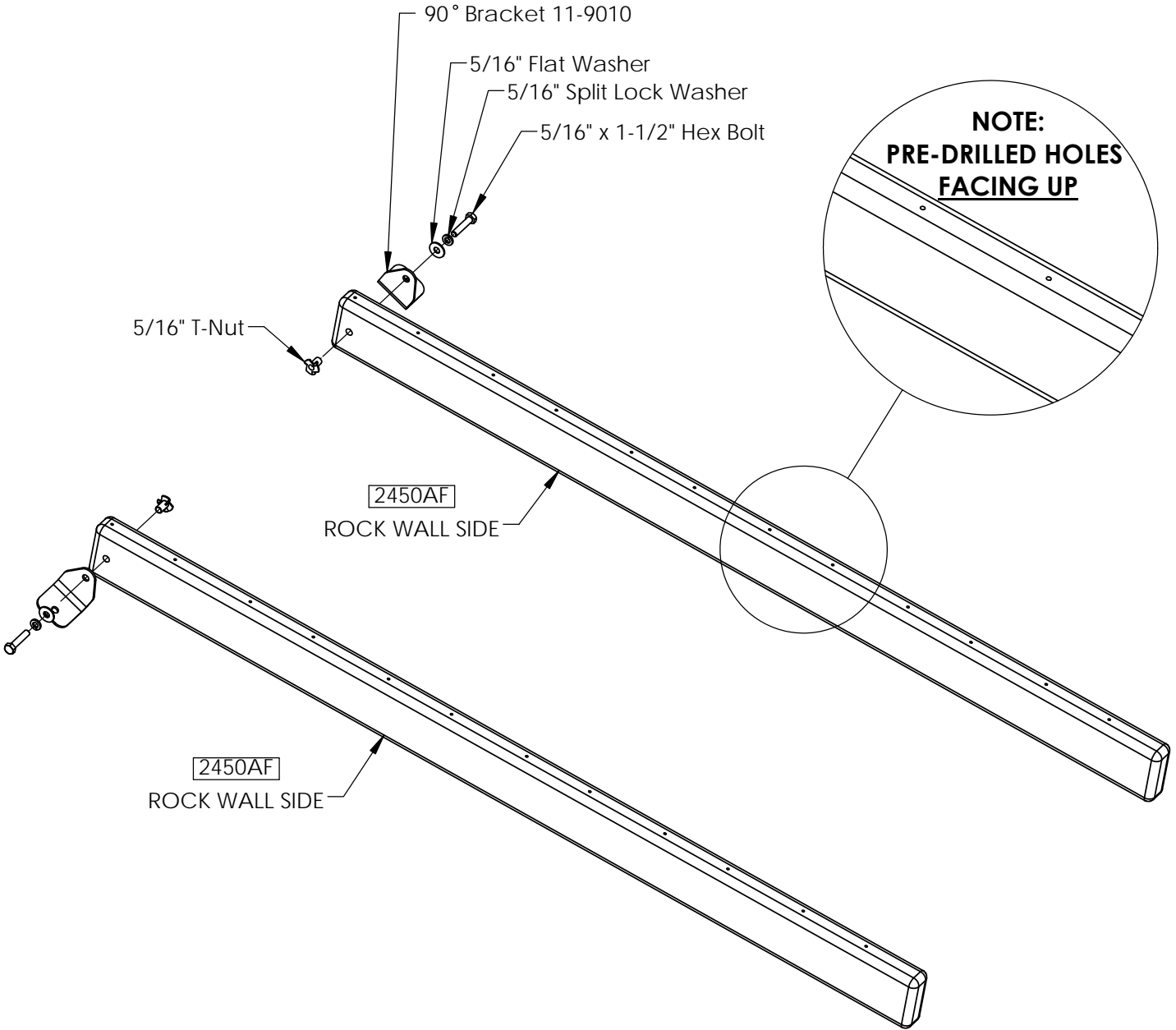

# STEP 16: ROCK WALL

1: POSITION THE ROCK WALL BOARDS ON TOP OF THE ROCK WALL SIDES BY LINING-UP ALL PRE-DRILLED HOLES.

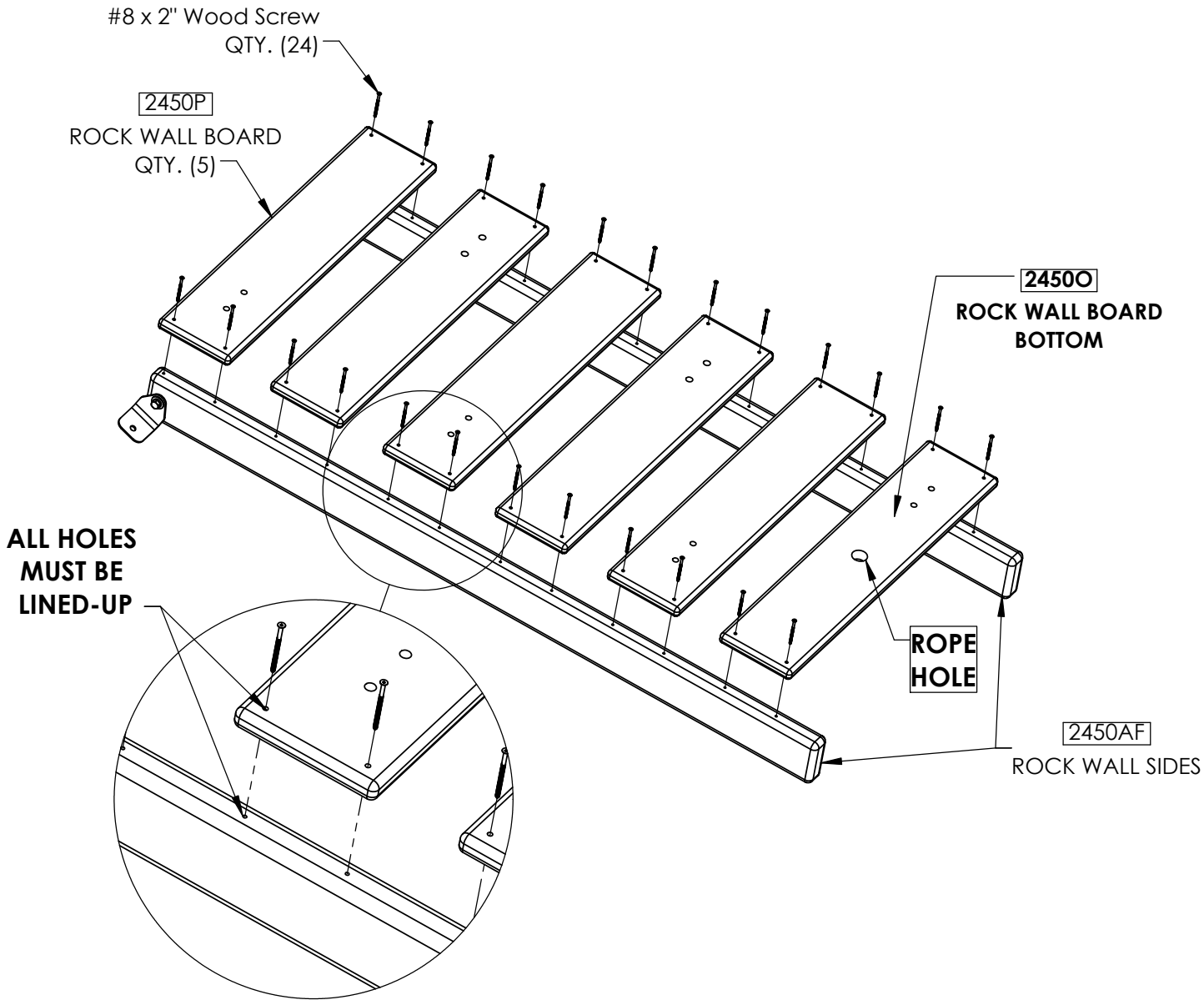

## STAGGERED PATTERN

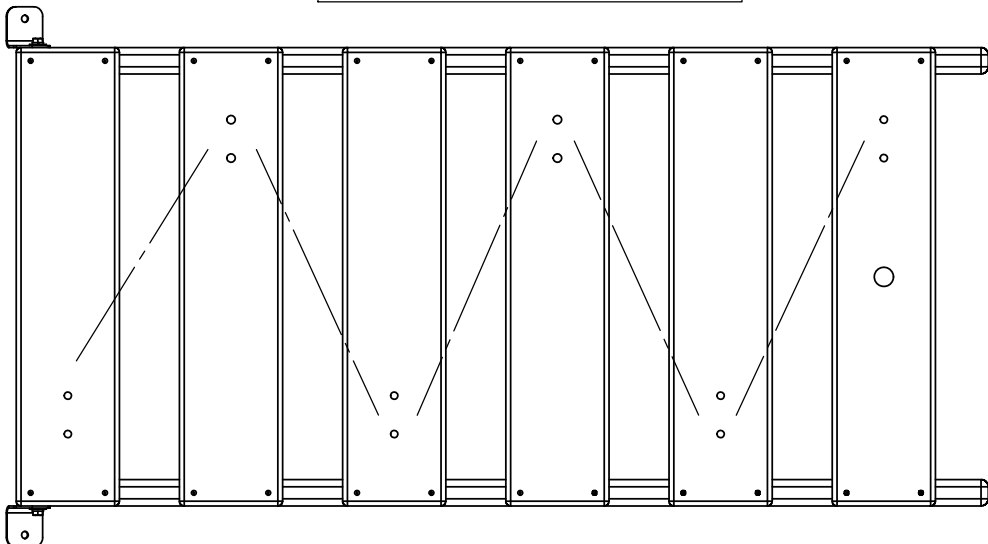

# STEP 17: ROCK WALL

1: THE ROCKS MUST BE LINED-UP TO THE ROCK WALL STAGGERED HOLES.

SEE DIAGRAM BELOW FOR MORE DETAILS.

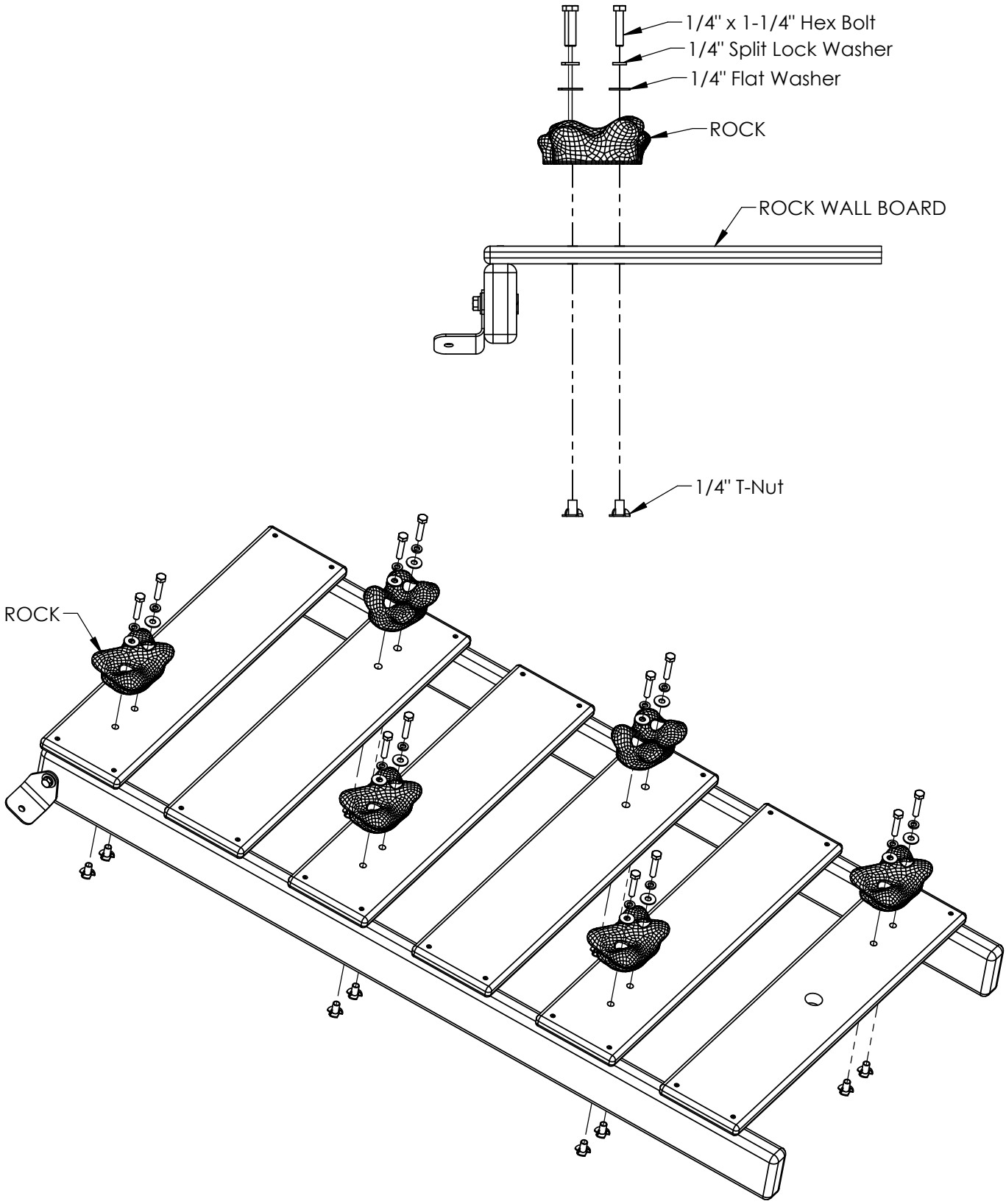



## STEP 18: ROCK WALL TO FORT

1: PLACE THE ROCK WALL CENTERED ON THE RIGHT SIDE ON THE FORT. THE BOTTOM EDGE OF THE GREEN BRACKETS SHOULD BE  $\frac{3}{4}$ " ABOVE THE BOTTOM OF THE PANEL SUPPORT. USING THE BRACKETS AS A TEMPLATE **DRILL A  $\frac{3}{8}$ " HOLE** THROUGH THE PANEL SUPPORT.

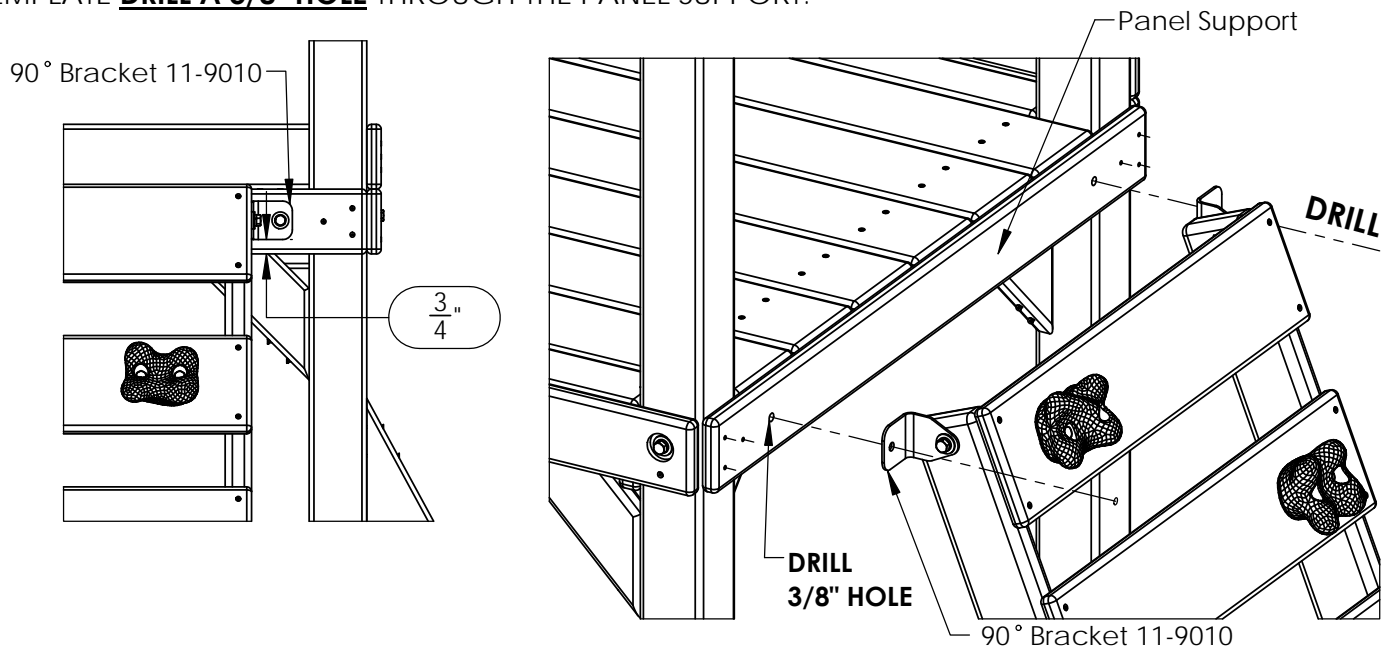

2: REMOVE **2450H** AND INSERT T-NUTS INTO THE BACK SIDE.

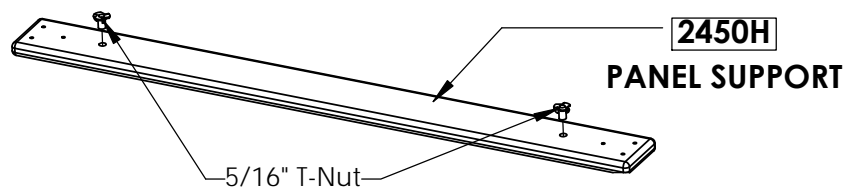

3: RE-INSTALL **2450H** USING 2-1/2" SCREWS AS SHOWN.

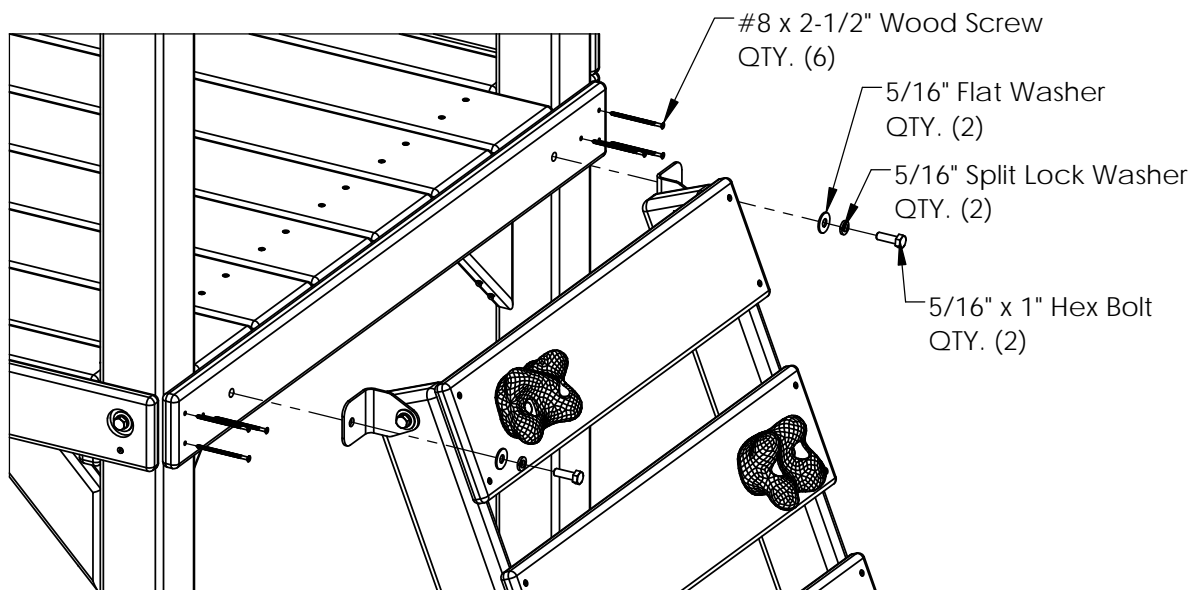

4: WHEN THE 90° BRACKETS ARE SECURE, AND THE ROCK WALL IS IN ITS FINAL POSITION; FULLY TIGHTEN ALL BOLTS.

# STEP 19: SWING BEAM IRON DUCTILE

1: LINE UP THE HOLES OF THE IRON DUCTILE WITH THE HOLES IN THE SWING BEAM.

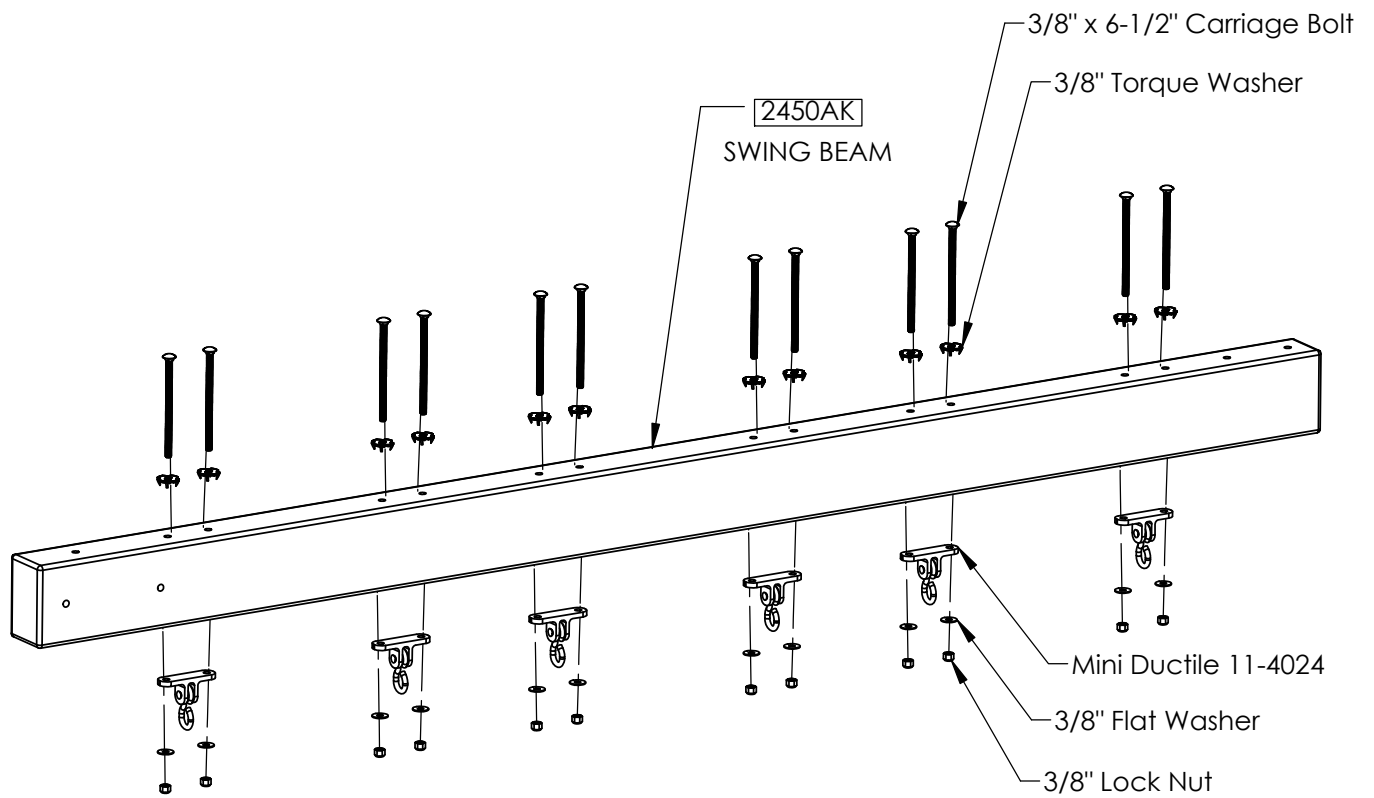

**\*\* FULLY TIGHTEN ALL HARDWARE \*\***

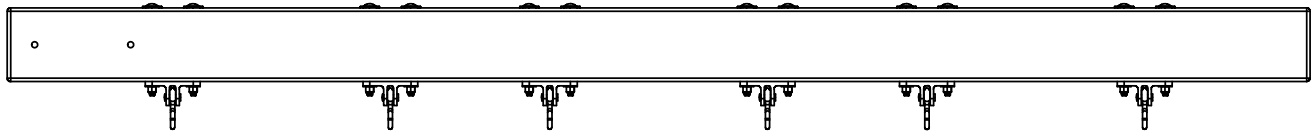

# STEP 20: SWING LEGS AND BRACKETS

**NOTE: BRACKETS ARE OPPOSITE FROM EACH OTHER.**

1: INSTALL BRACKETS TO SWING LEGS AS SHOWN BELOW.

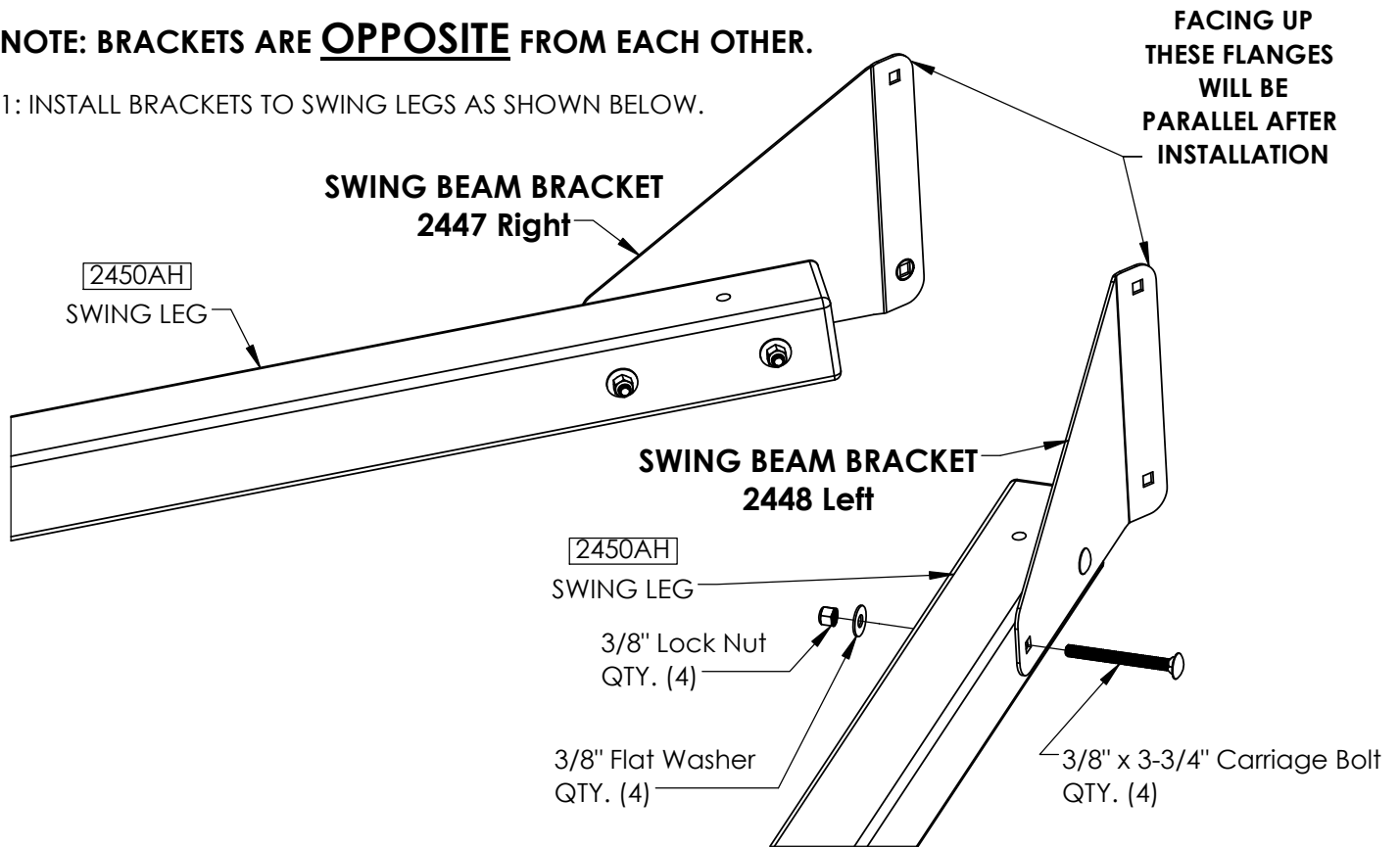

2: FLIP THE SWING LEGS OVER SO THE BRACKETS POINT DOWN KEEPING THE FLANGES PARALLEL TO EACH OTHER.

3: INSTALL THE L-BRACKET TO SWING LEGS AS SHOWN.

**NOTE: DO NOT FULLY TIGHTEN FASTENERS AT THIS POINT.**

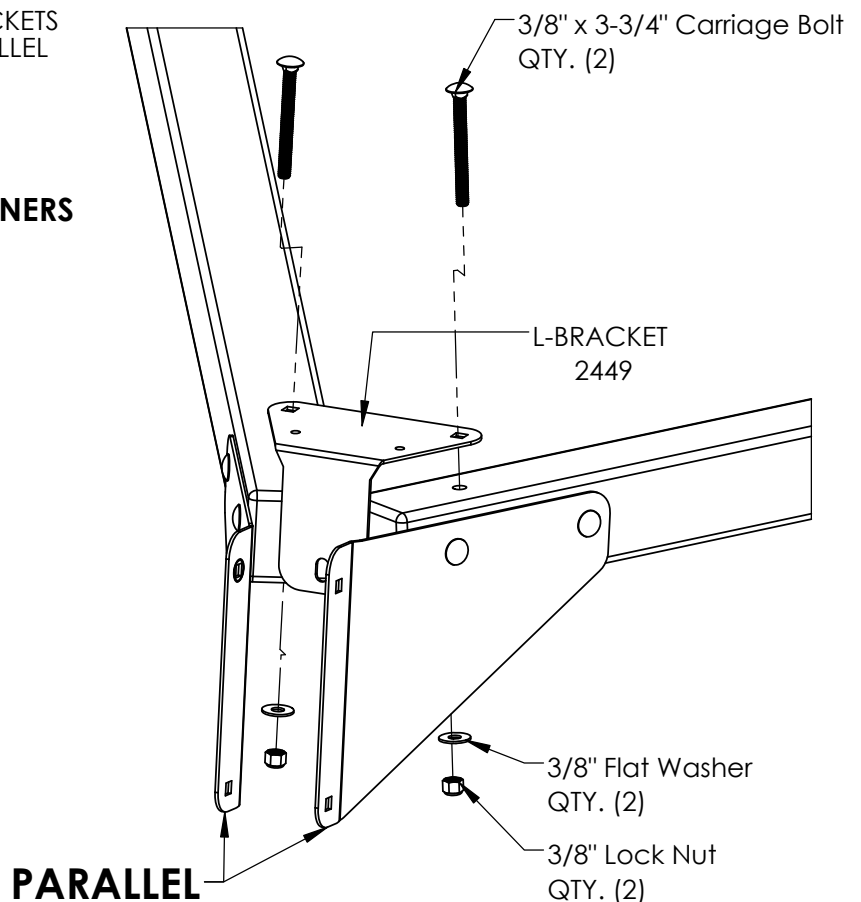

# STEP 21: CROSS MEMBER

1: INSTALL CROSS MEMBER TO SWING LEGS AS SHOWN BELOW. **DO NOT FULLY TIGHTEN FASTENERS**

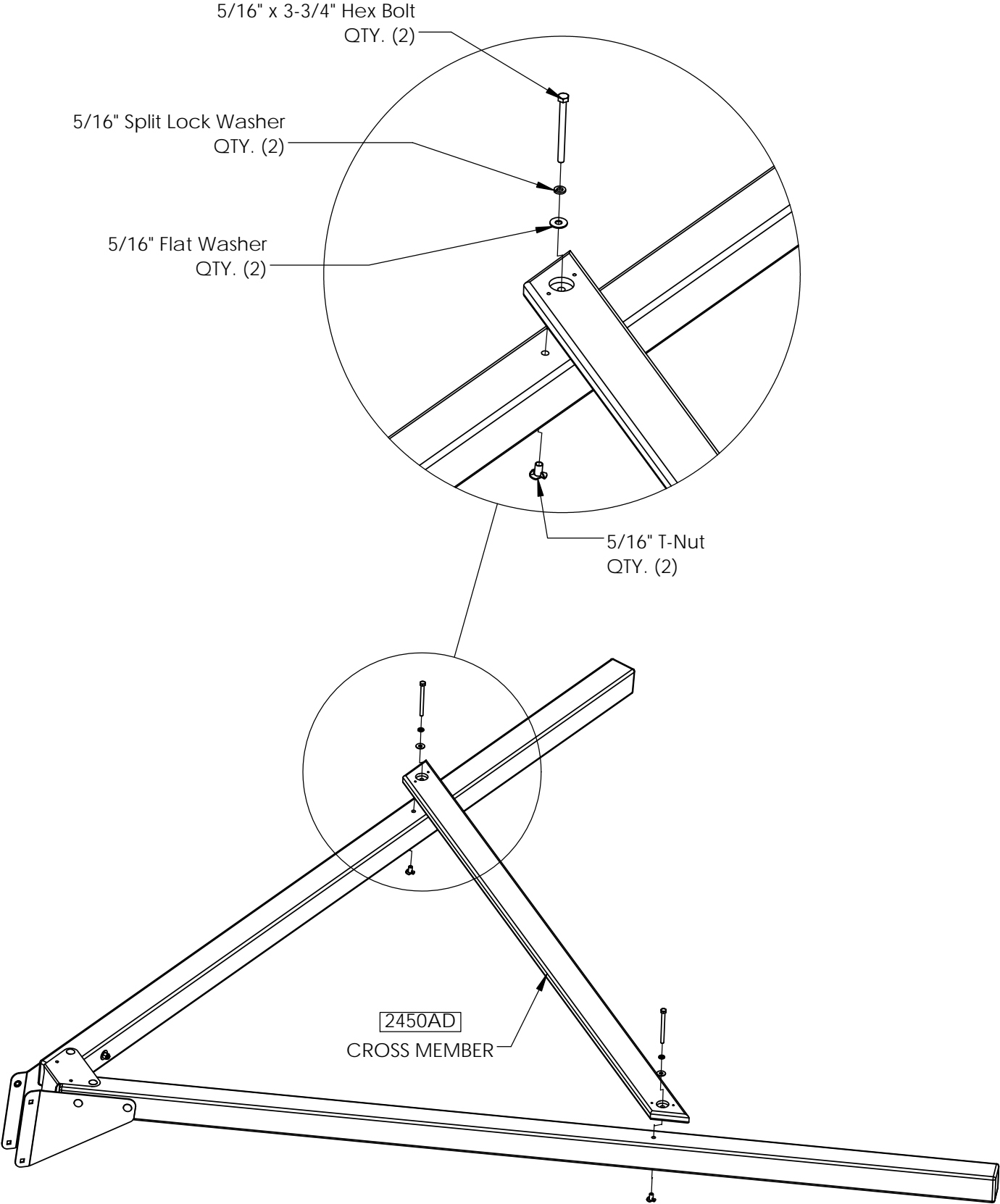

# STEP 22: SWING BEAM TO SWING BEAM LEGS

1: CAREFULLY PLACE THE SWING BEAM BETWEEN THE SWING BEAM BRACKETS (LEFT & RIGHT) AS SHOWN IN THE DIAGRAM BELOW.

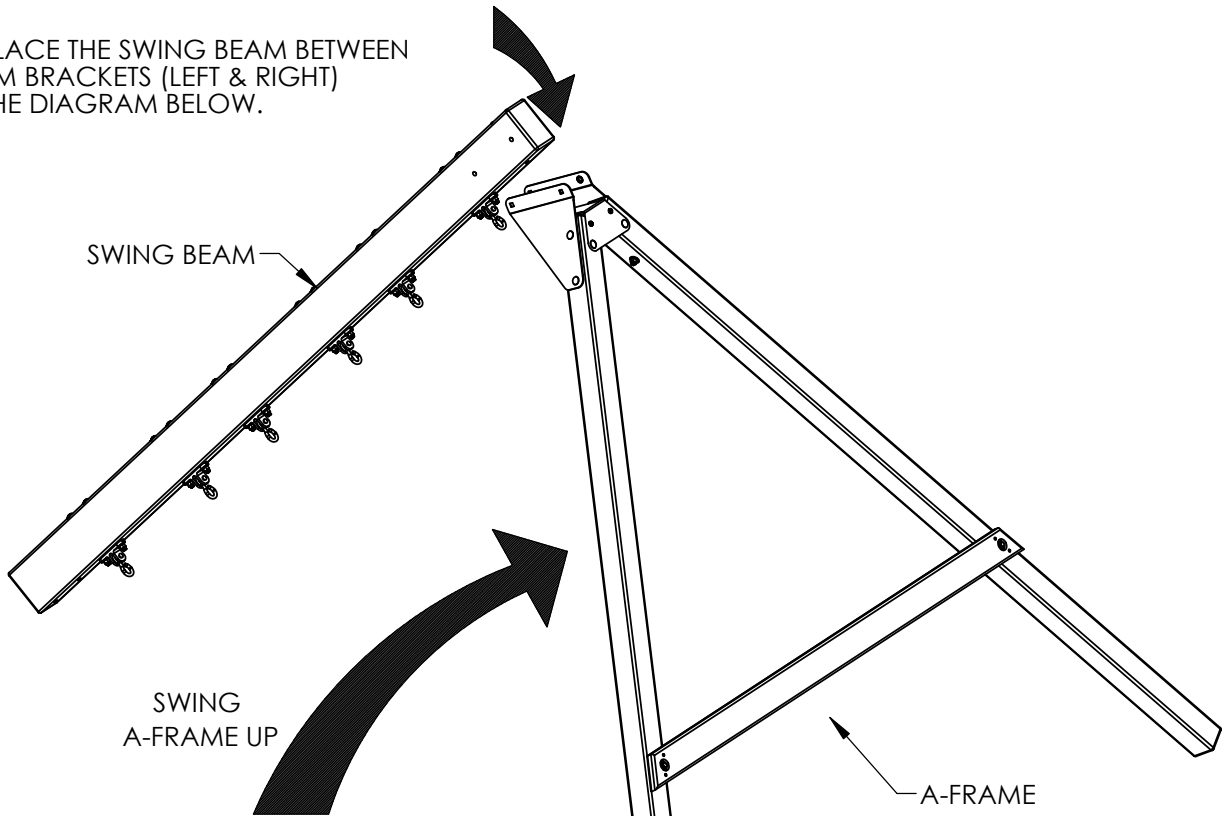

**2: DO NOT FULLY TIGHTEN FASTENERS AT THIS POINT.**

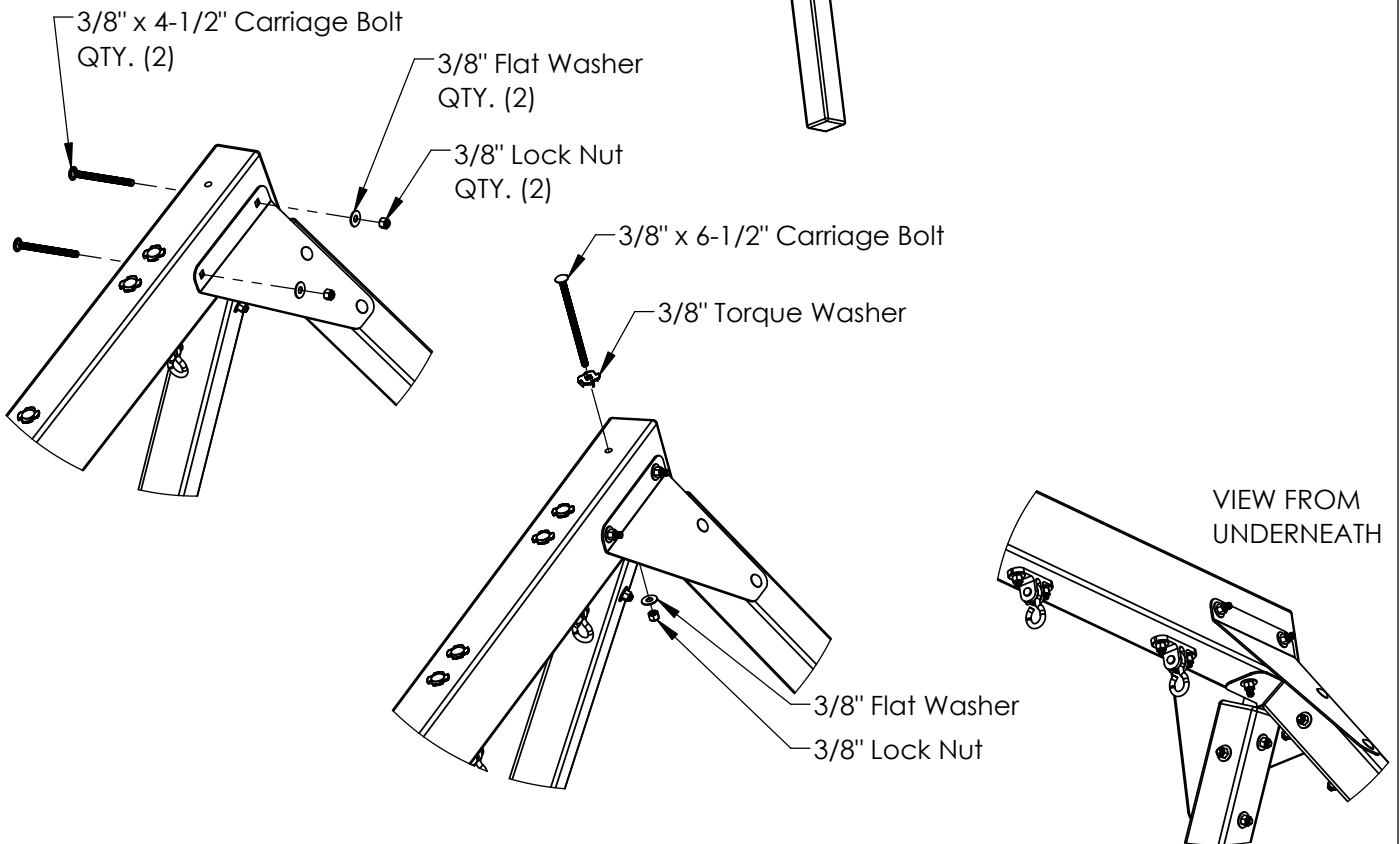

# STEP 23: MOUNT SWING BEAM TO FORT

**\*\* AN EXTRA PERSON IS NEEDED FOR THIS STEP \*\***

1: PLACE THE SWING BEAM ON TOP OF THE SWING BEAM PLATE/SWING BEAM SUPPORT.

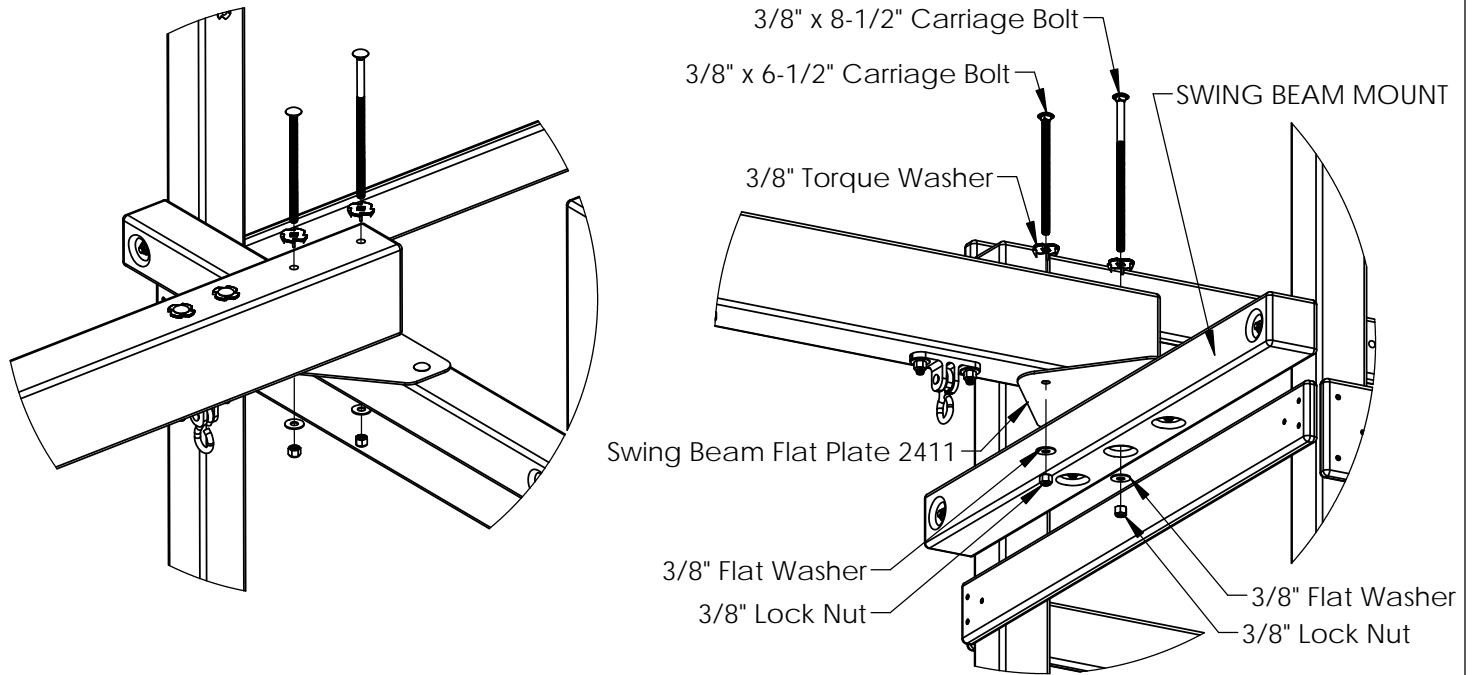

**NOTE: FULLY TIGHTEN ALL FASTENERS FROM PREVIOUS STEPS**

2: INSERT FASTENERS AS SHOWN BELOW.

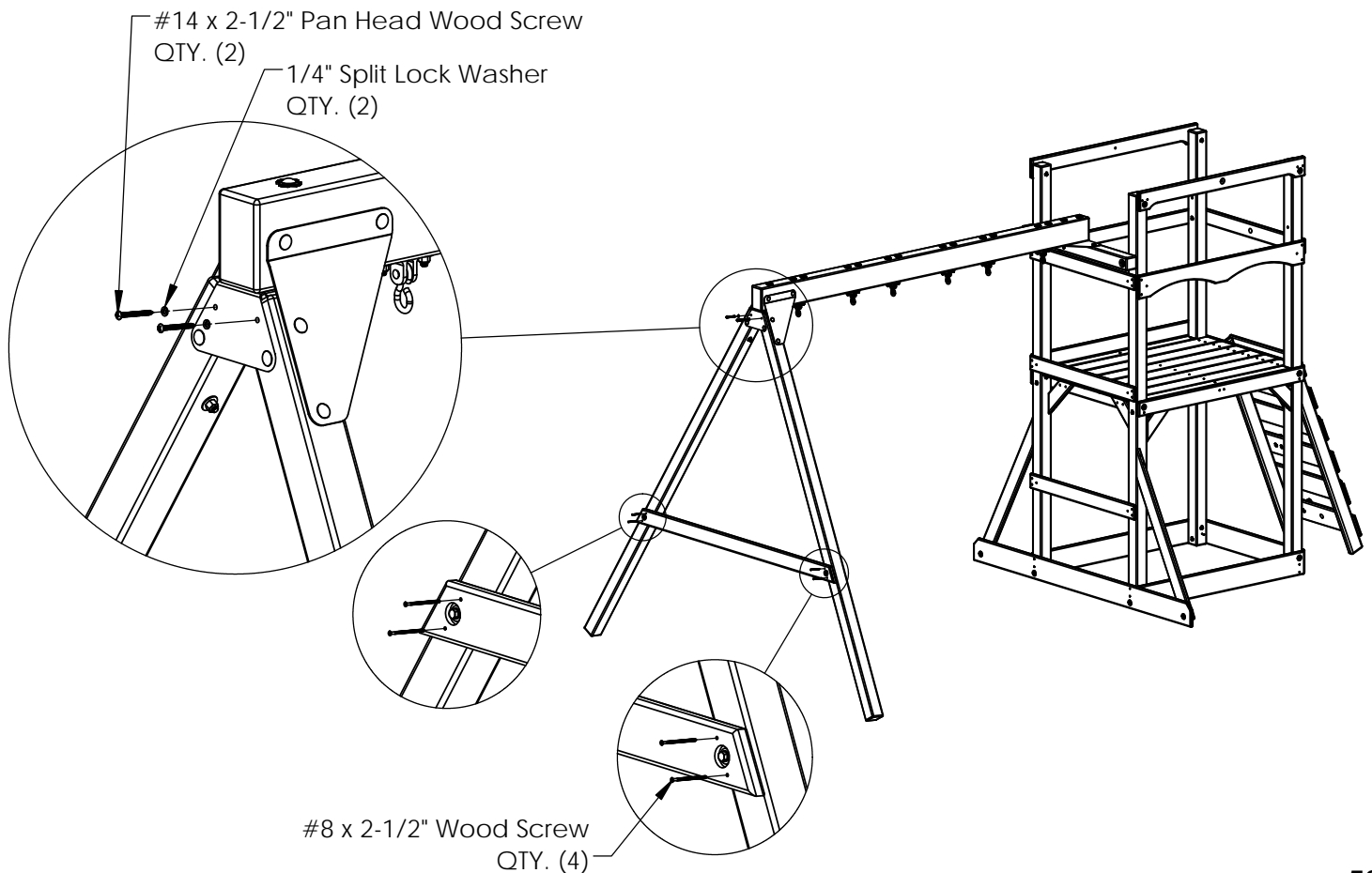

## STEP 24: LEVELING THE SWING BEAM

MAKE SURE SWING BEAM IS LEVEL.

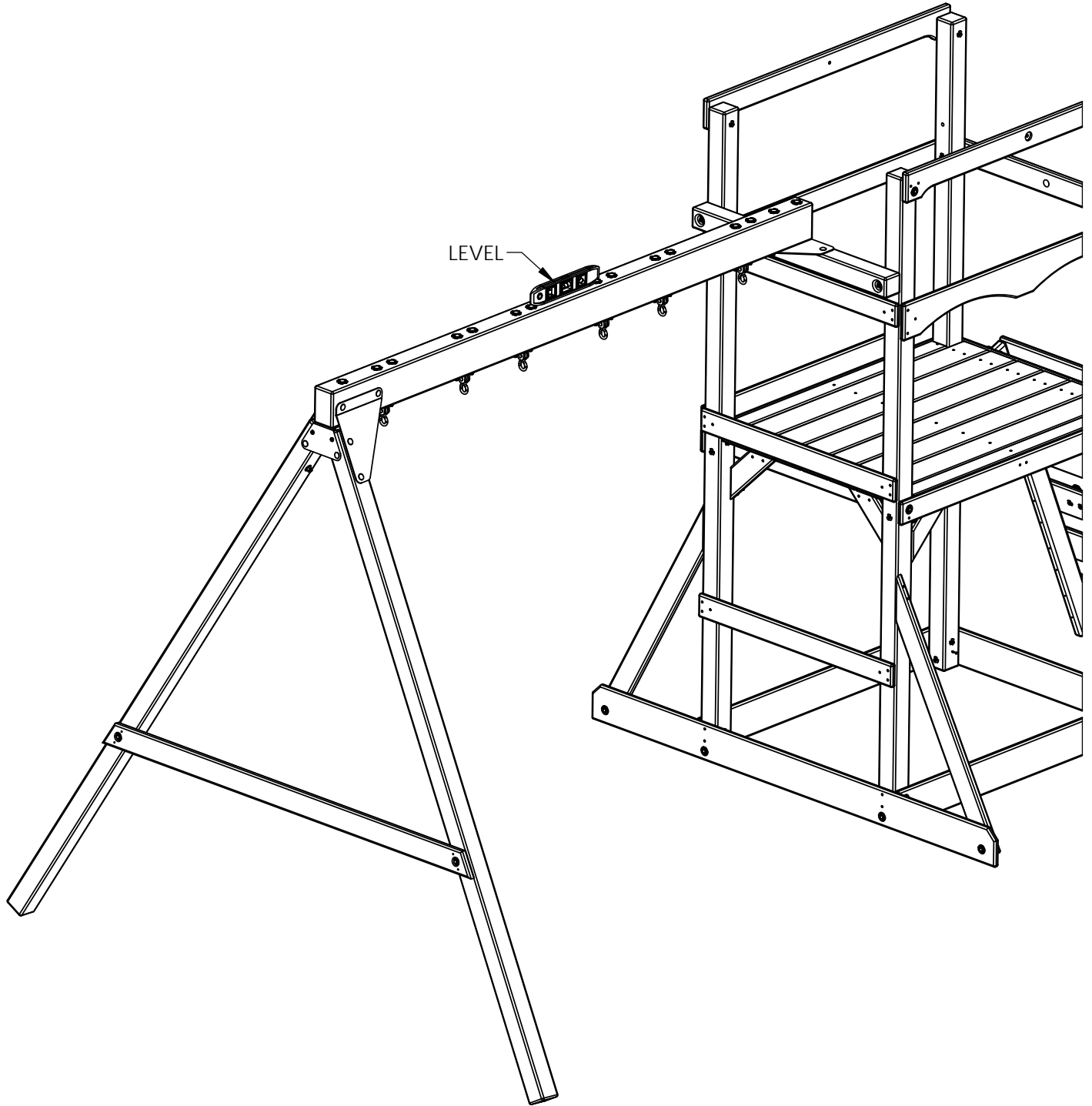

# STEP 25: PANEL SLATS

1: INSTALL ALL PANEL SLATS AS SHOWN IN THE DIAGRAM BELOW.

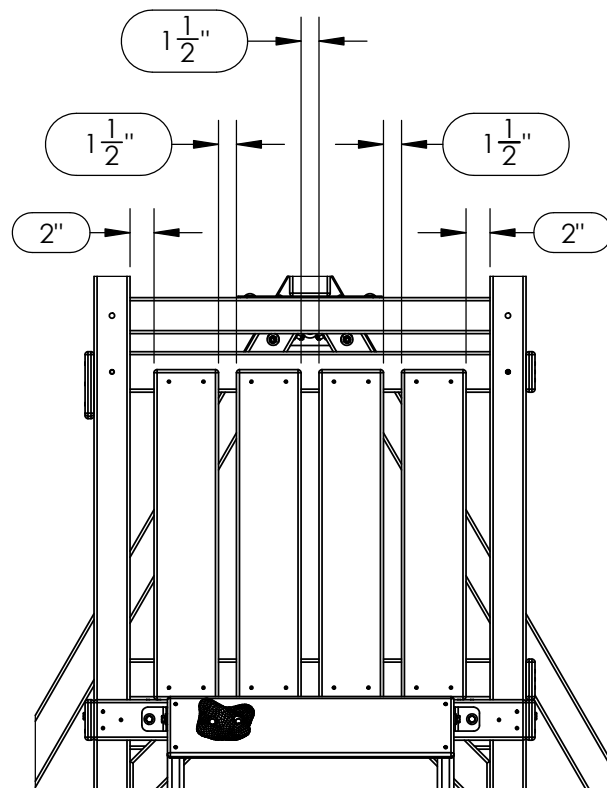
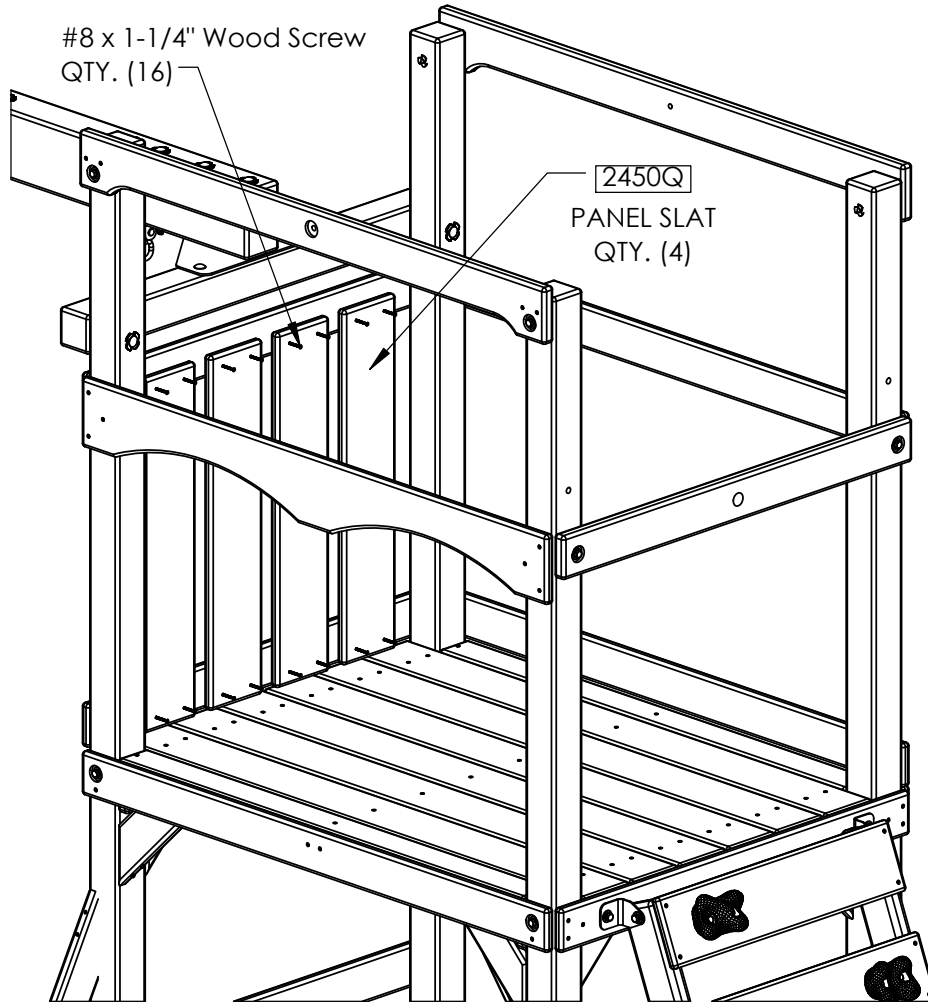

**SWING BEAM PANEL**



# STEP 26: PANEL SLATS

1: INSTALL ALL PANEL SLATS AS SHOWN IN THE DIAGRAM BELOW.

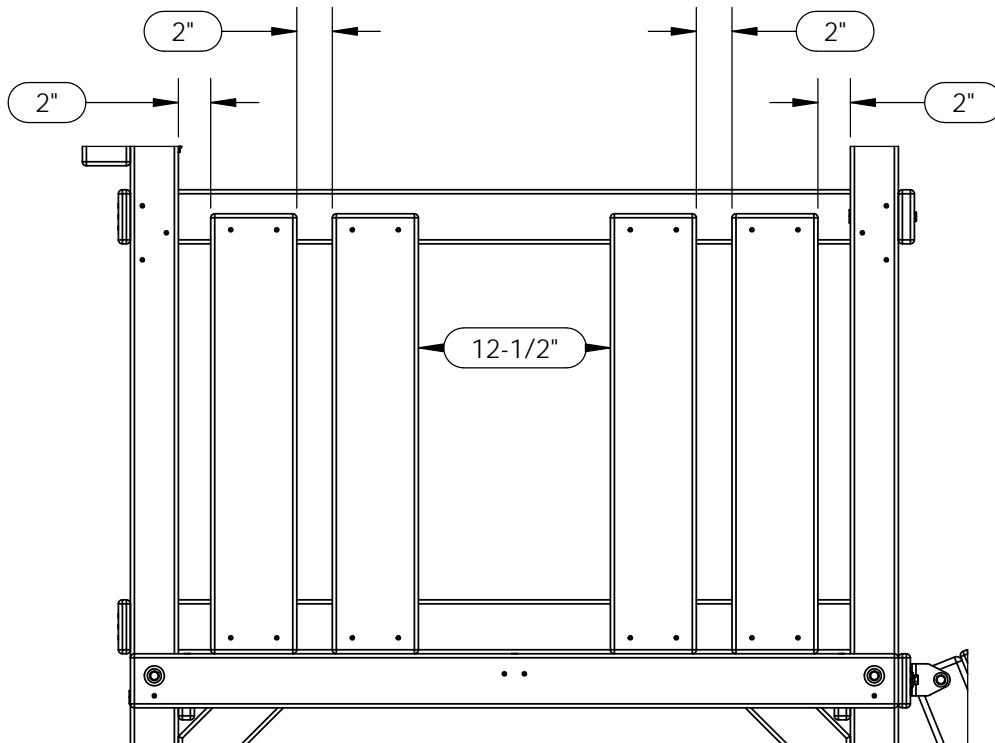
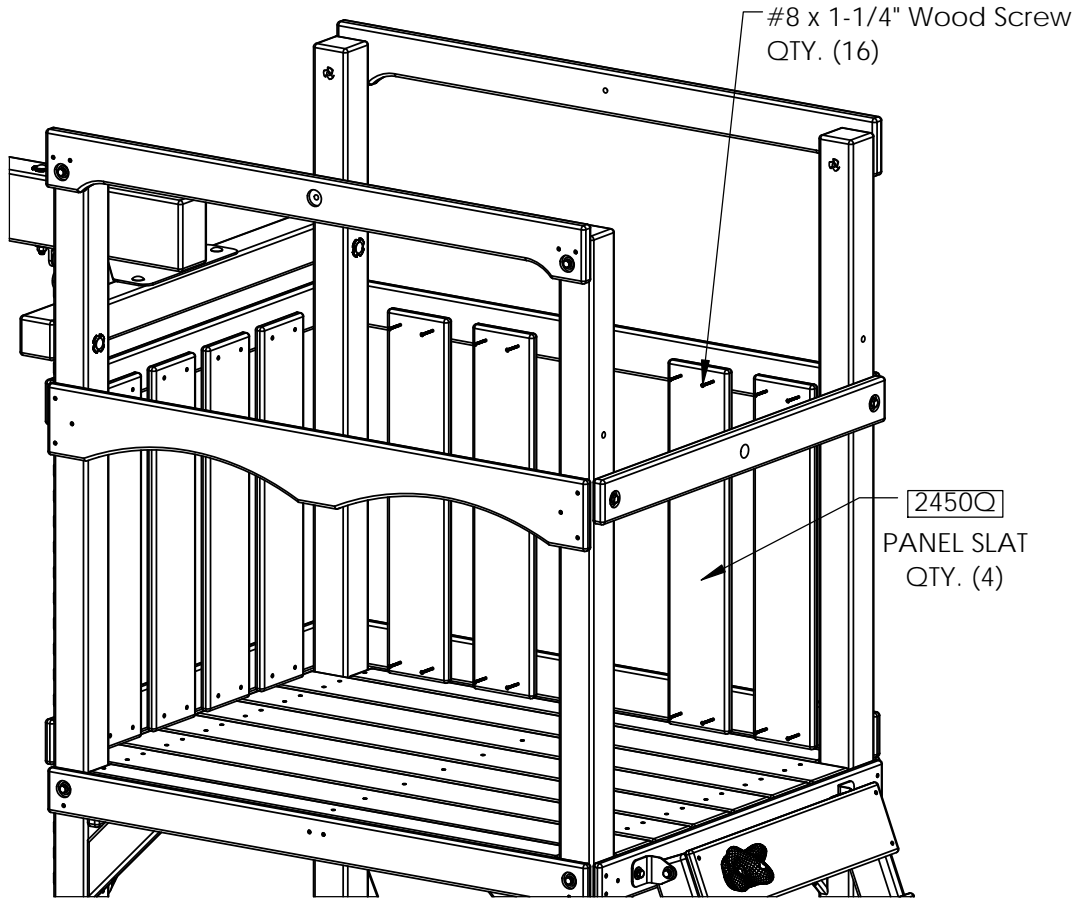

**REAR PANEL**

# STEP 27: CENTER POST

1: LINE UP THE TOP HOLE OF THE TARP CENTER POST WITH THE REAR TARP SUPPORT HOLE. SEE DIAGRAM FOR DETAILS.

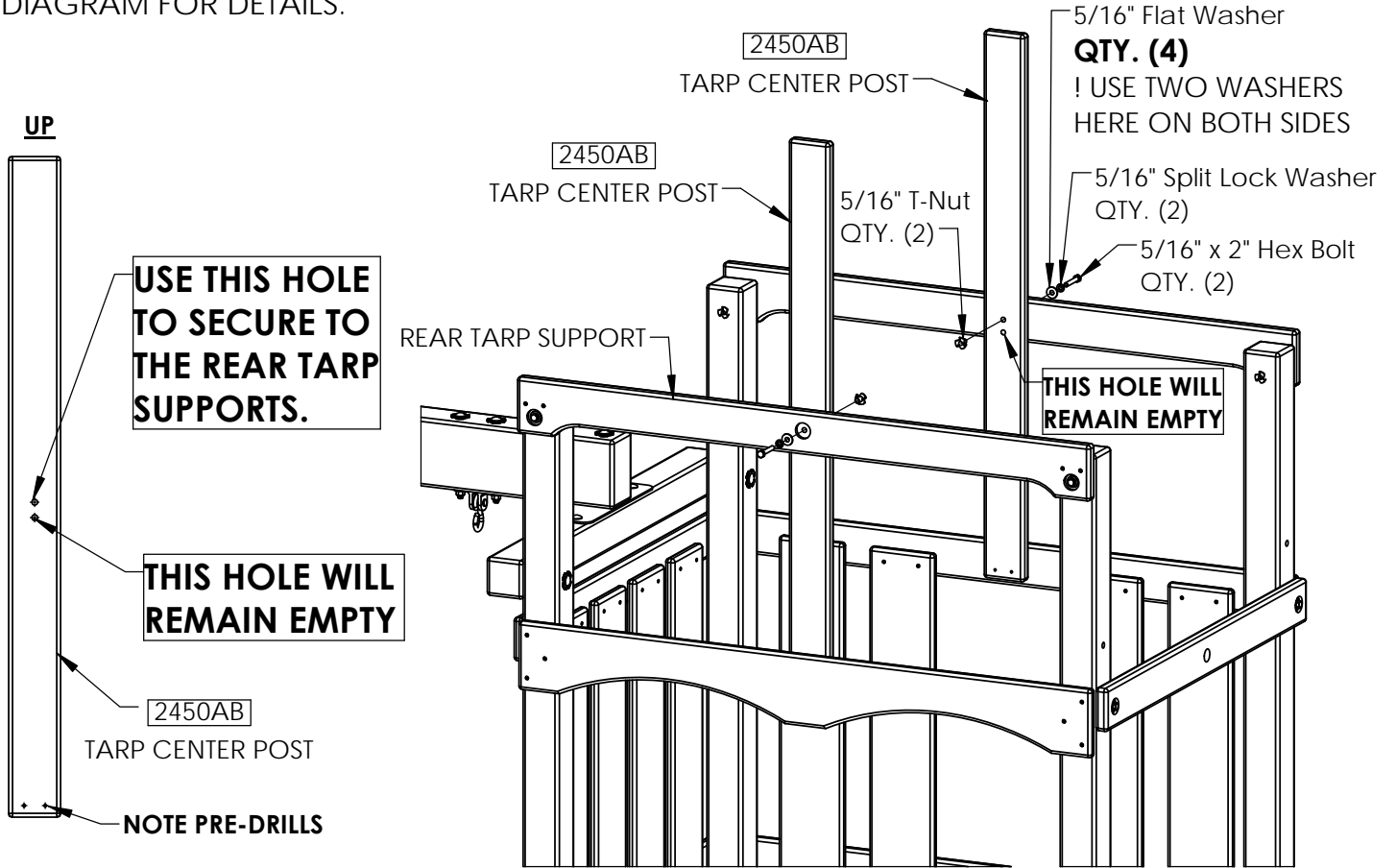

2: **SQUARE EACH TARP CENTER POST TO EACH REAR TARP SUPPORT BEFORE ADDING WOOD SCREWS.**

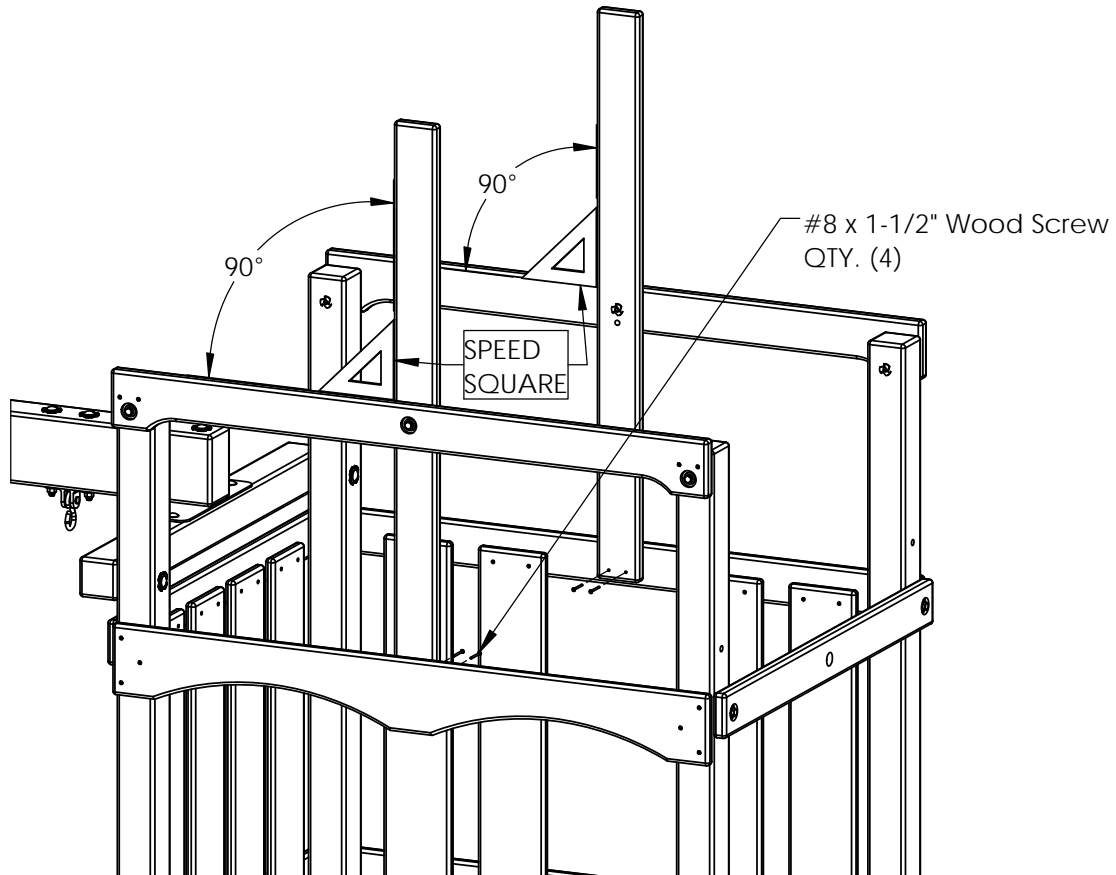

# STEP 28: WINDOW PANEL BOARDS

1: INSTALL BOARDS AS SHOWN BELOW.

**\*\*VIEW FROM INSIDE OF FORT\*\***

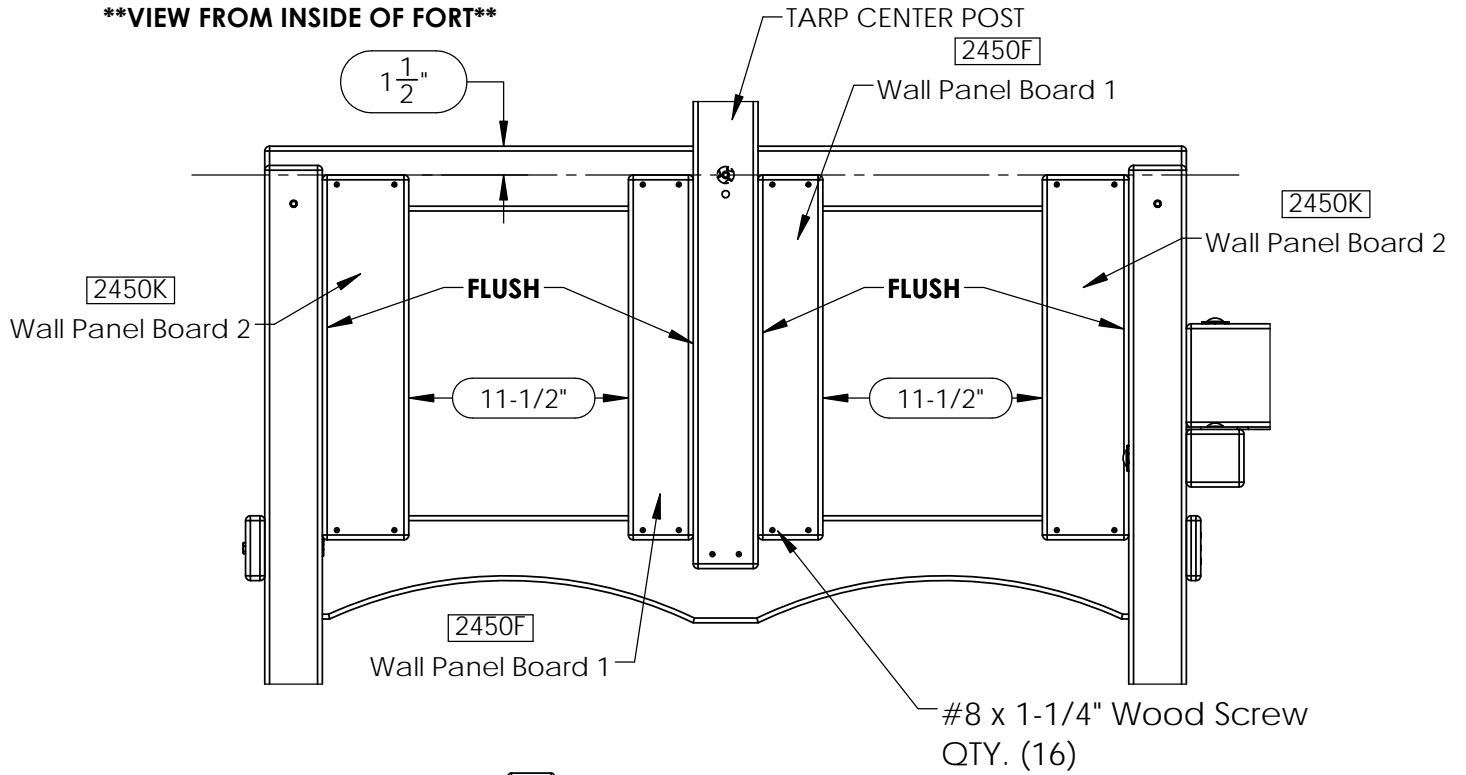

**\*\*VIEW FROM OUTSIDE OF FORT\*\***

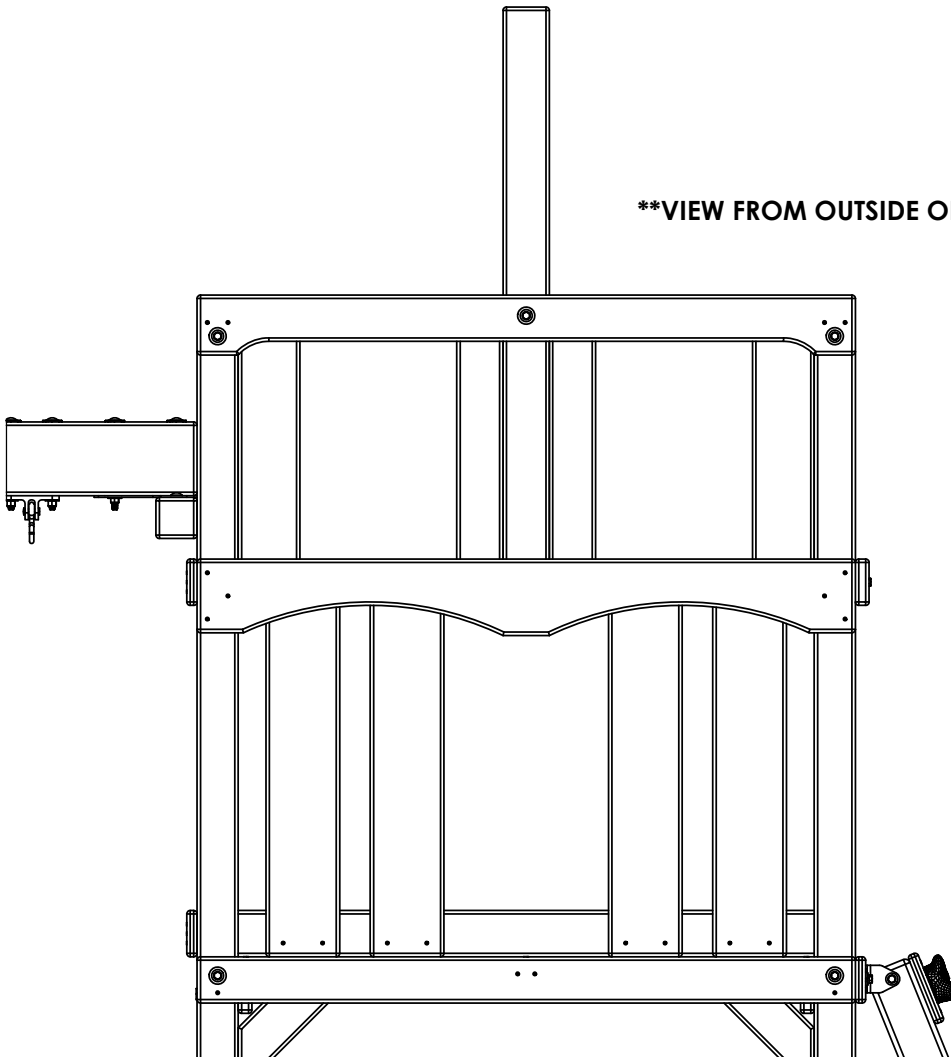

# STEP 29: WINDOWS

1: CENTER EACH WINDOW SIDE TO SIDE IN THE OPENING.

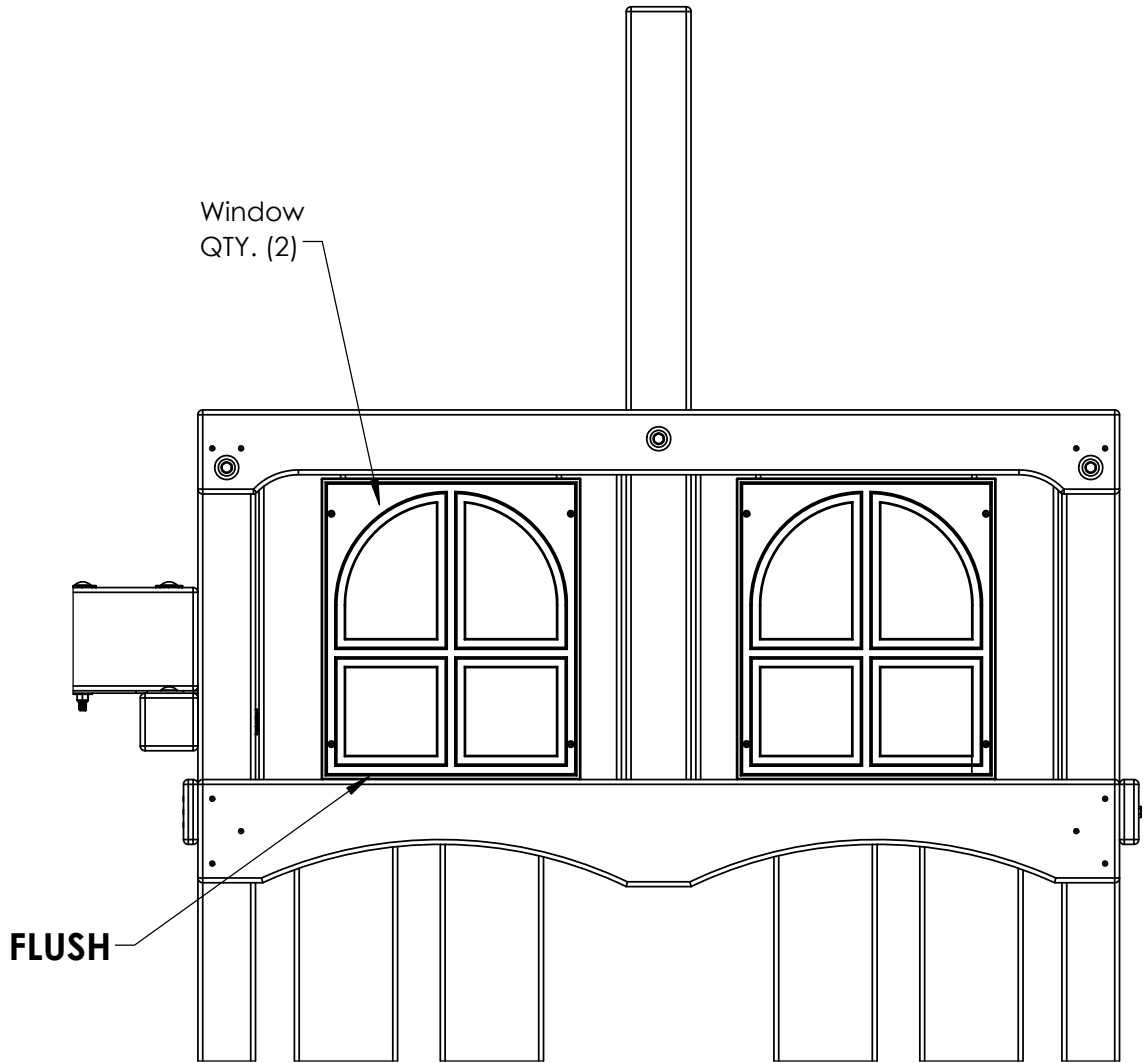

#8 x 1" Wood Screw  
QTY. (8)

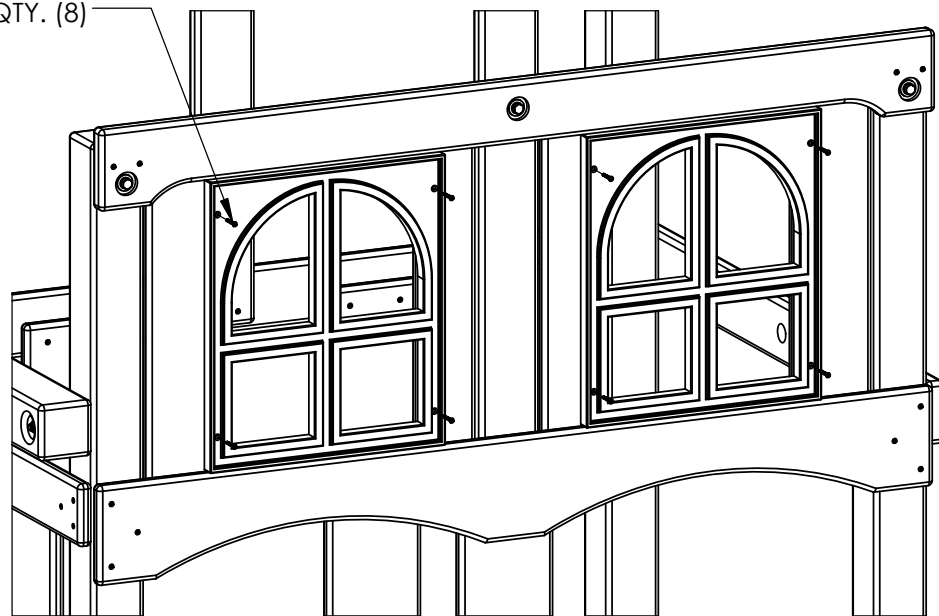

# STEP 30: TARP BOARDS

1: ATTACH BOARDS TO PLAY SET AS SHOWN BELOW.

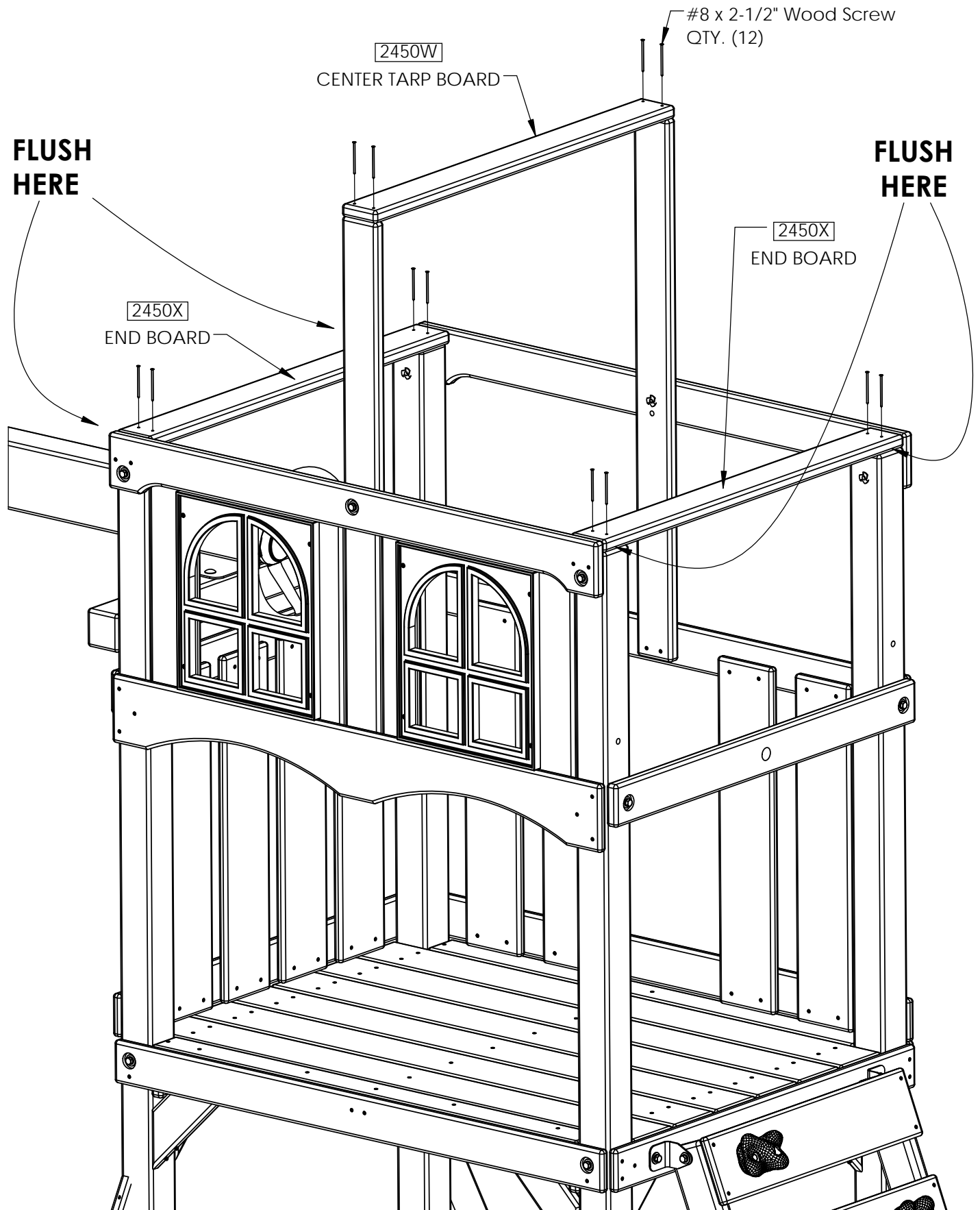

# STEP 31: SUN

1: EACH SUN MOUNTS ON TOP OF THE REAR TARP SUPPORT BOARDS CENTERED FROM SIDE TO SIDE.

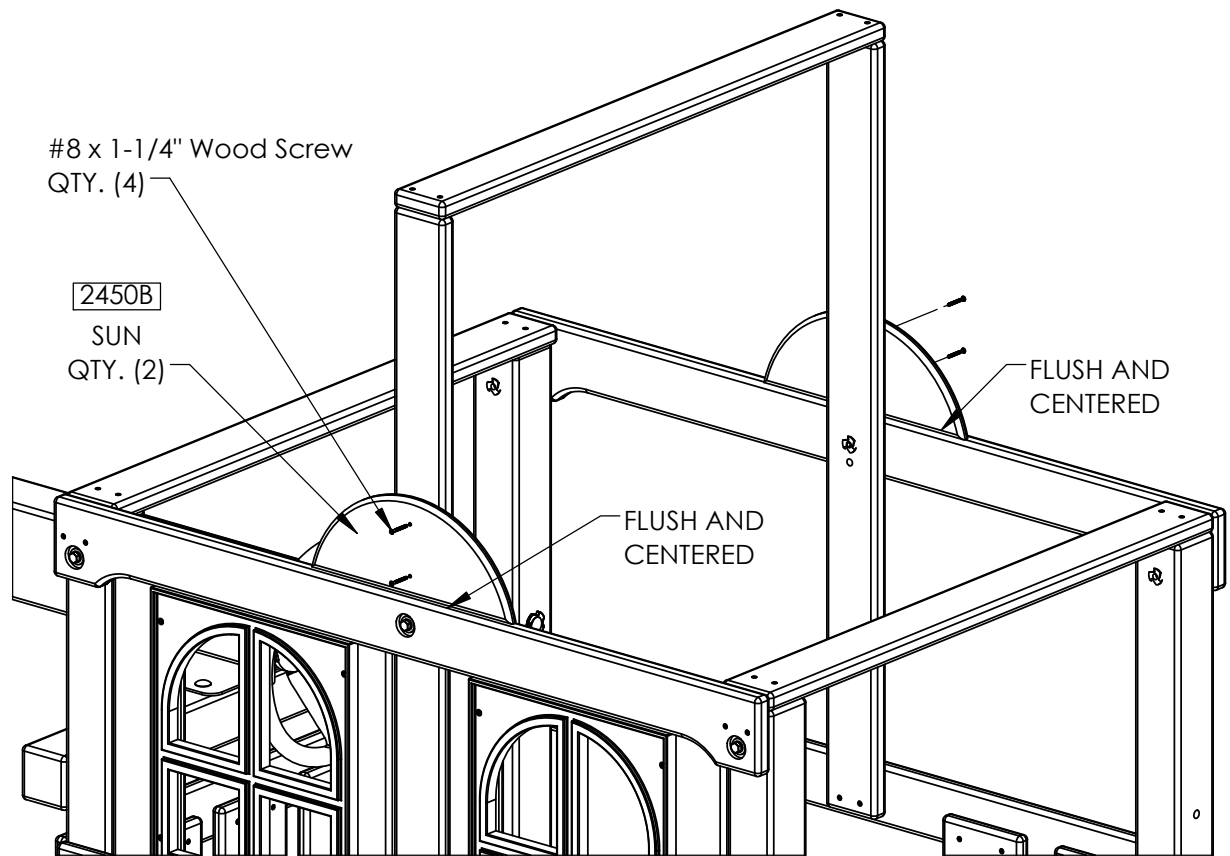

2: PLACE THE PLASTIC SUN ON TOP OF THE **FRONT SUN ONLY**.

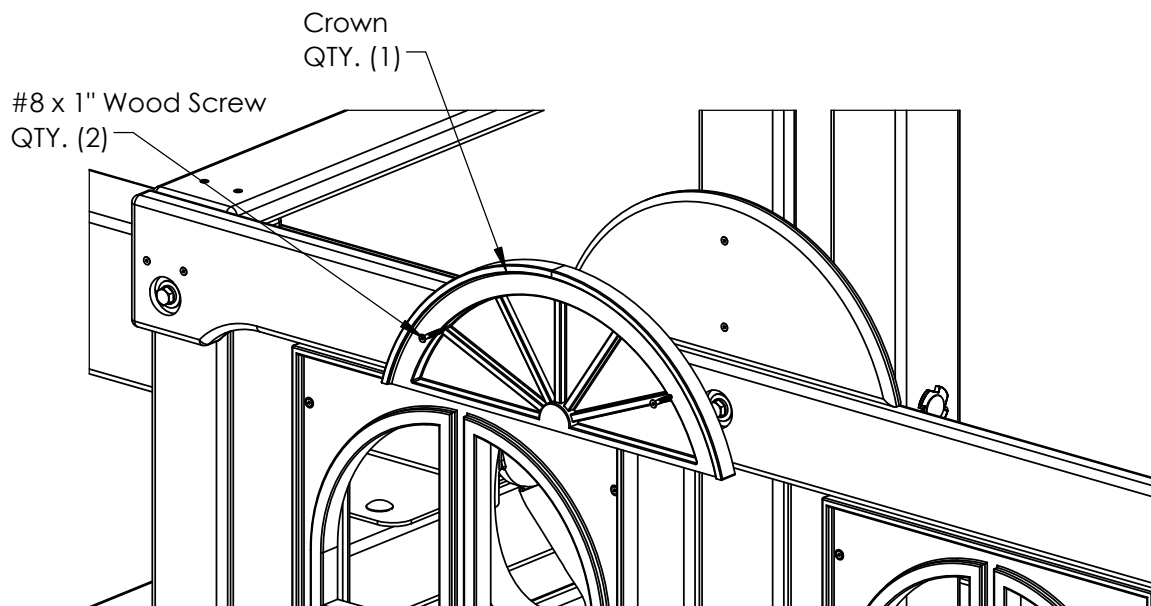

## STEP 32: TARP

1: PLACE THE TARP ACROSS THE TARP BOARDS WITH THE HEMS ON THE INSIDE.

**NOTE: IF YOU WISH YOU MAY PREDRILL HOLES FOR THE PAN HEAD SCREWS WITH A 1/8" DRILL BIT.**

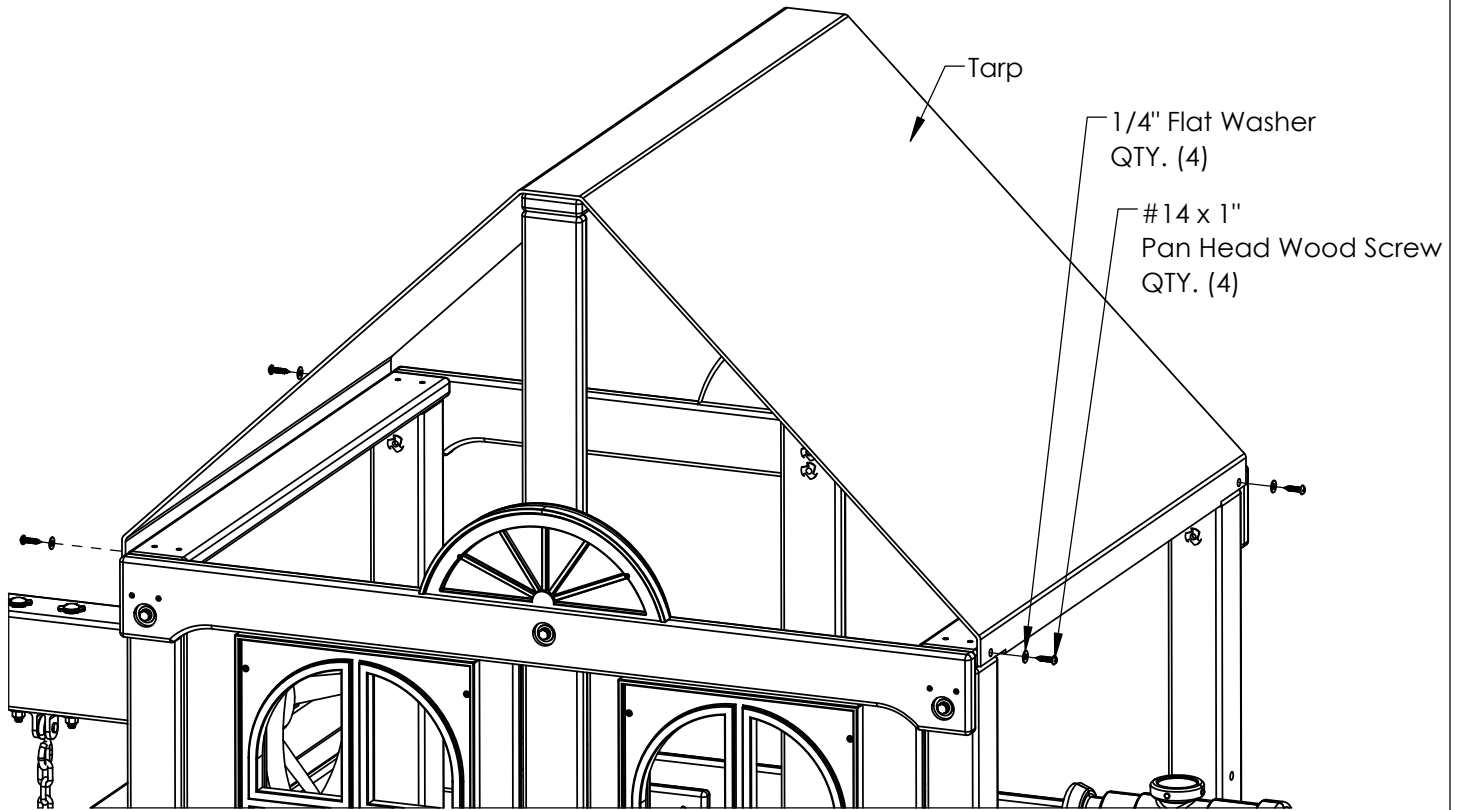

2: FOLD THE FLAP UNDER THE TARP BOARD.

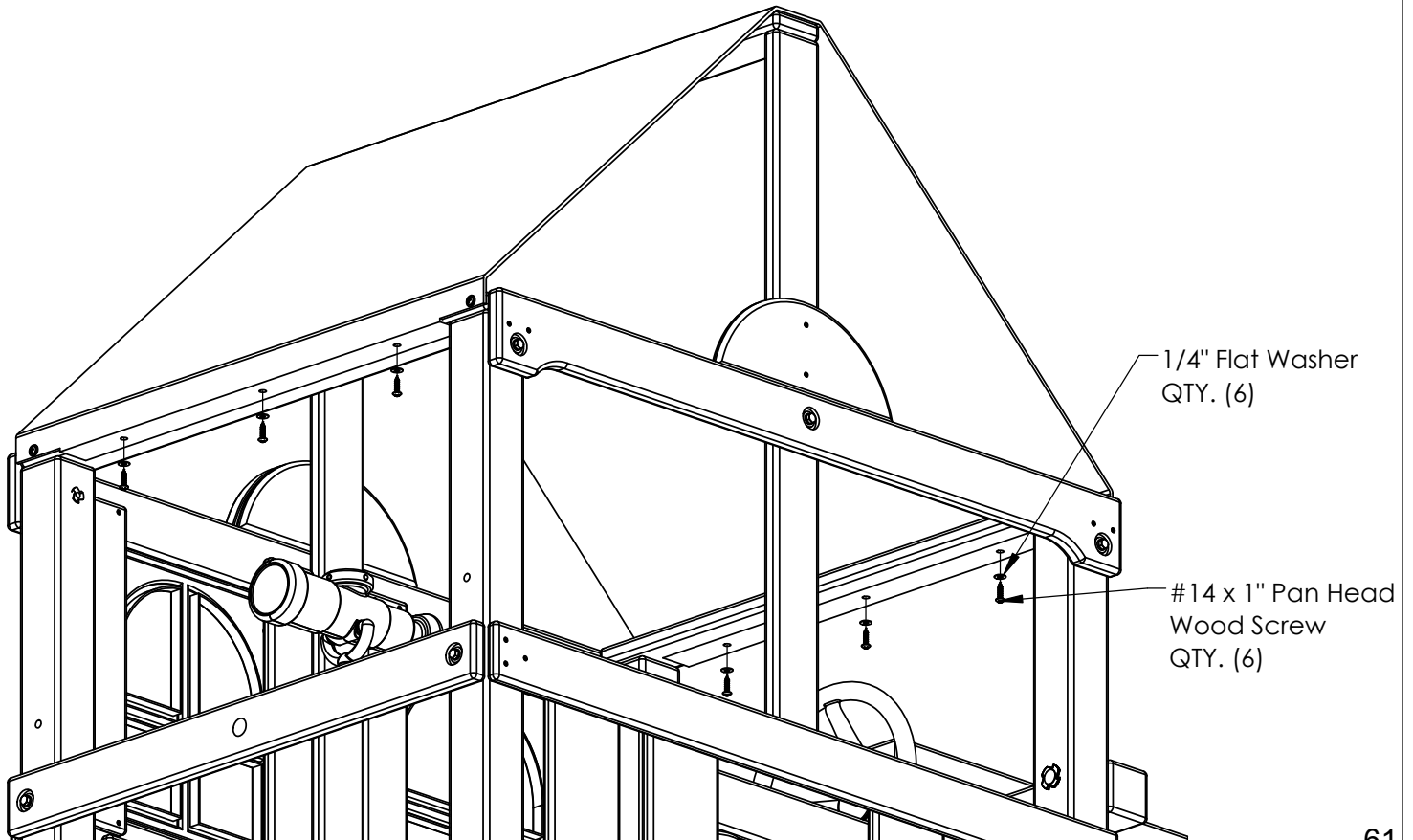

# STEP 33: ROOF PEAK SUPPORT

1: PLACE THE ROOF PEAK SUPPORT FLUSH AND CENTERED AT THE TOP OF THE TARP.

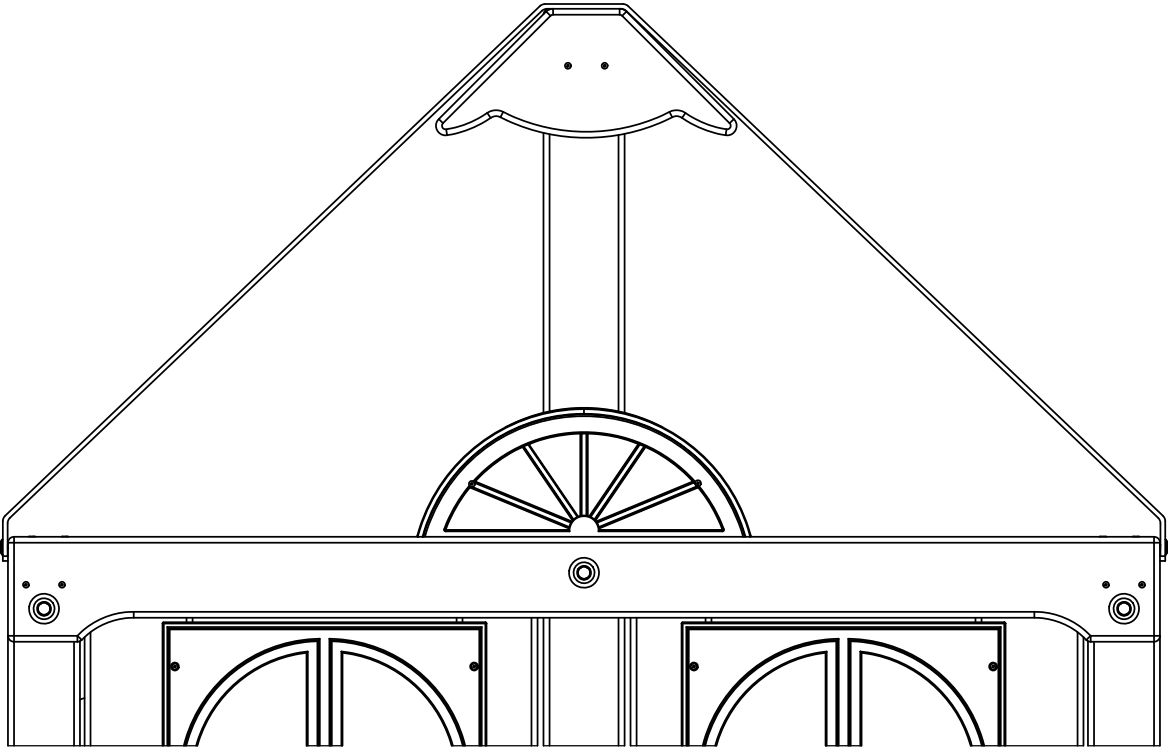
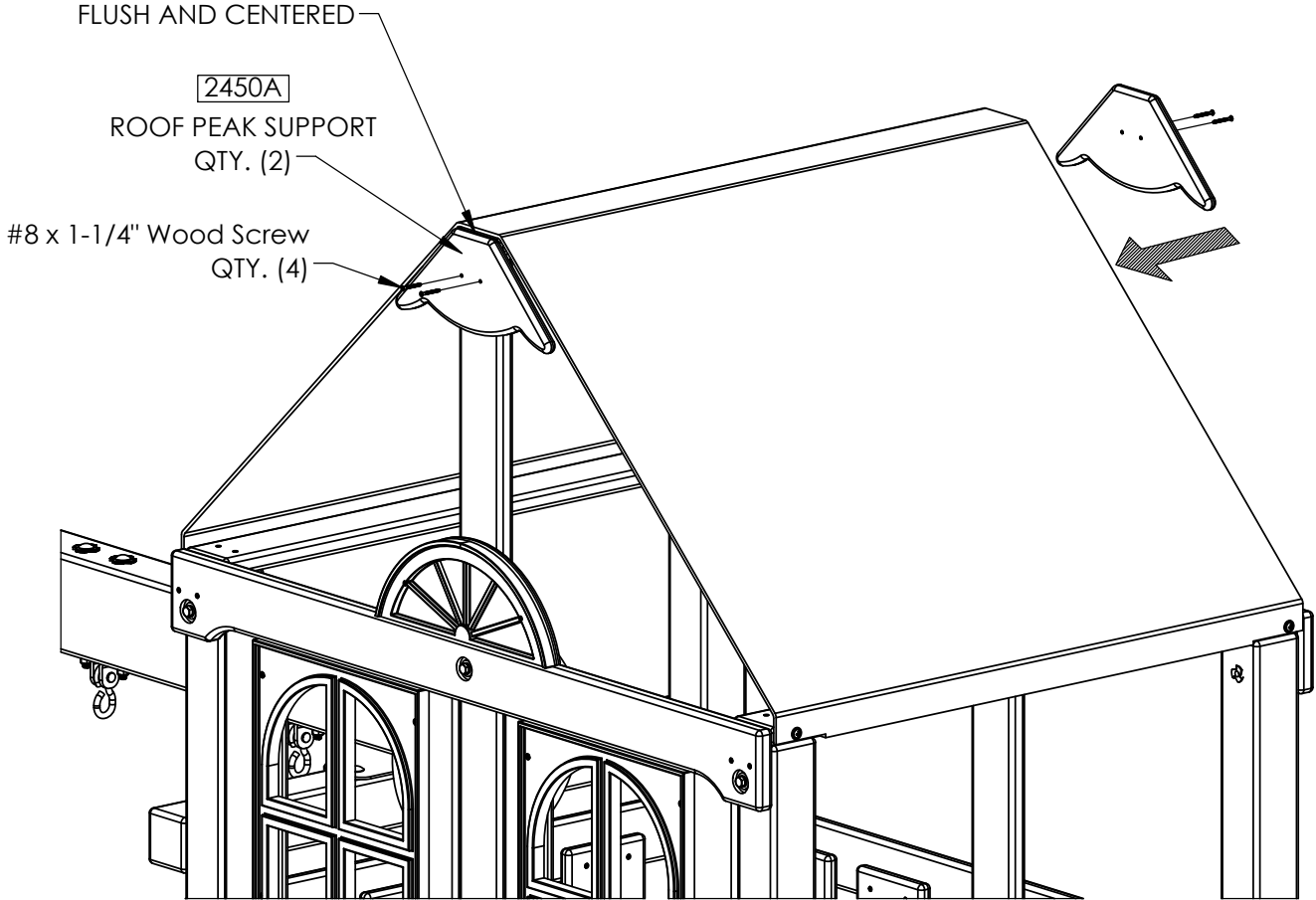



## STEP 34: TIC TAC TOE ASSEMBLY

1: CENTER AND FASTEN THE TIC TAC TOE MOUNTS TO THE GREEN TIC TAC TOE BRACKETS WITH THE SHORT SCREWS PROVIDED IN THE TIC TAC TOE BOX.

2: ASSEMBLE THE TIC TAC TOE ACCORDING TO THE INSTRUCTIONS PROVIDED IN THE BOX.

**\*\* IGNORE STEPS 6 AND 7 IN THE TIC TAC TOE INSTRUCTIONS PROVIDED IN THE BOX \*\***

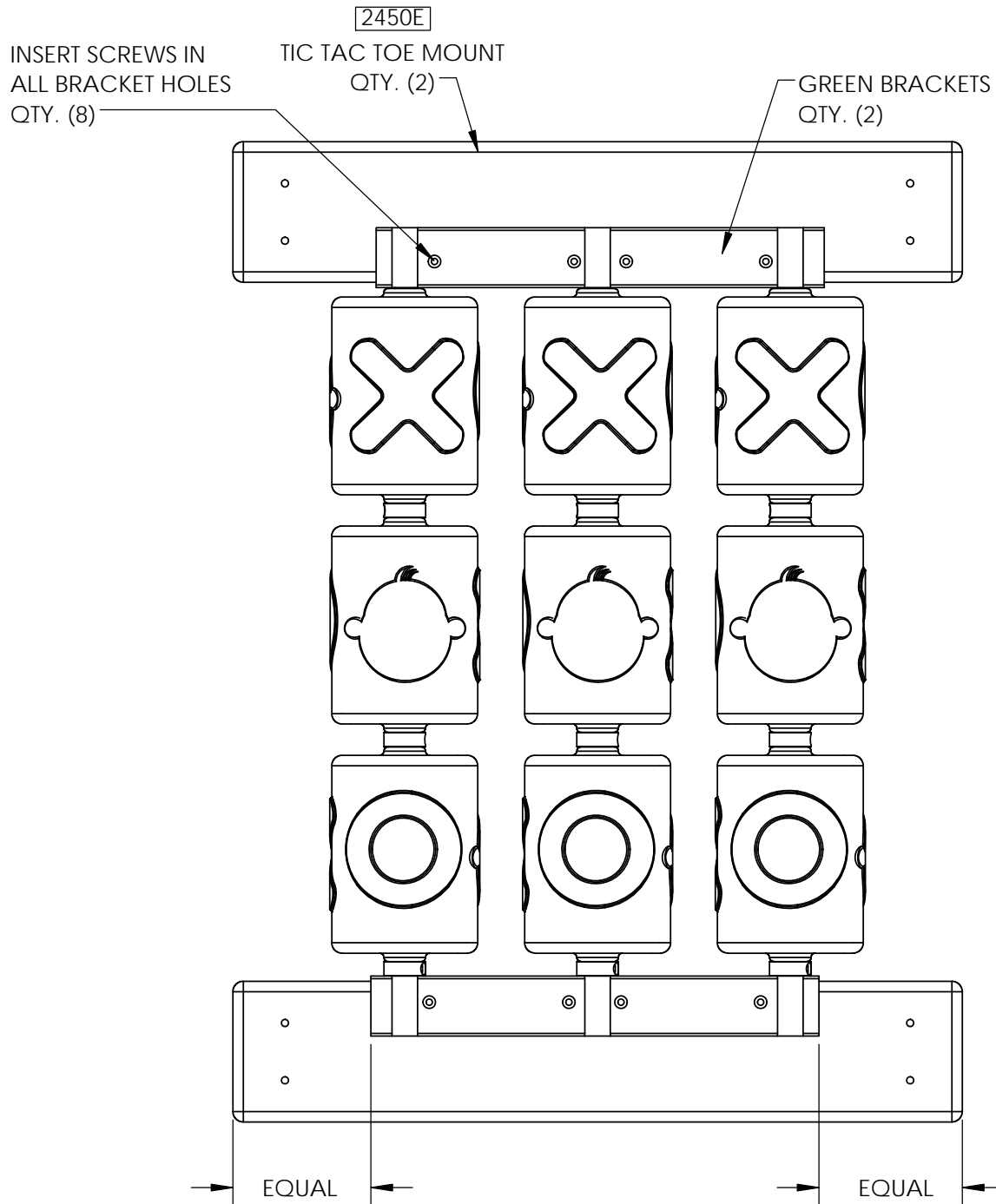

## STEP 35: MOUNTING TIC TAC TOE PANEL

1: PLACE THE TIC TAC TOE PANEL ASSEMBLY ONTO THE BACK WALL. THE LOWER TIC TAC TOE MOUNT BOARD SHOULD BE 2" ABOVE THE DECK.

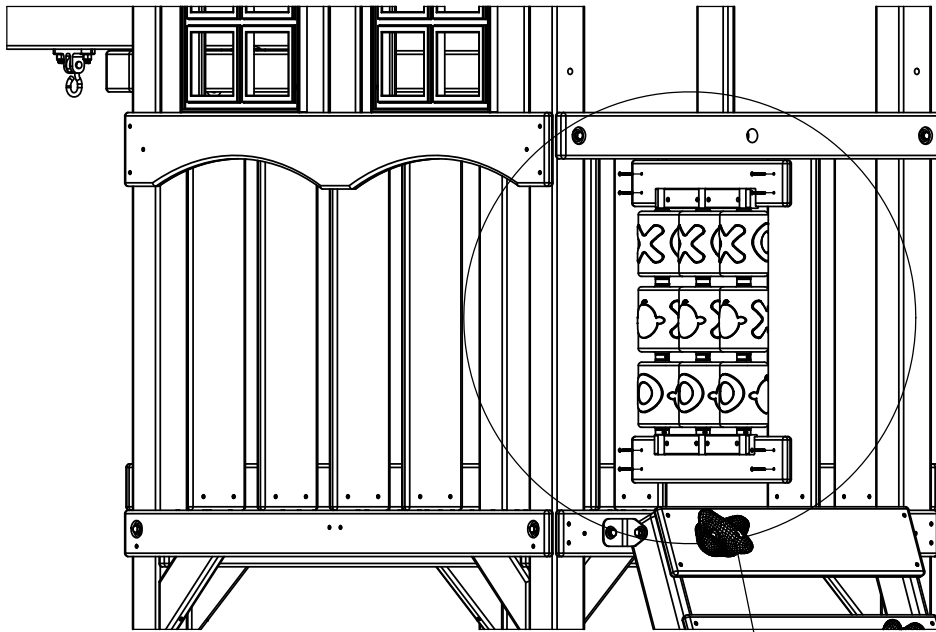

#8 x 1-1/4" Wood Screw  
QTY. (8)

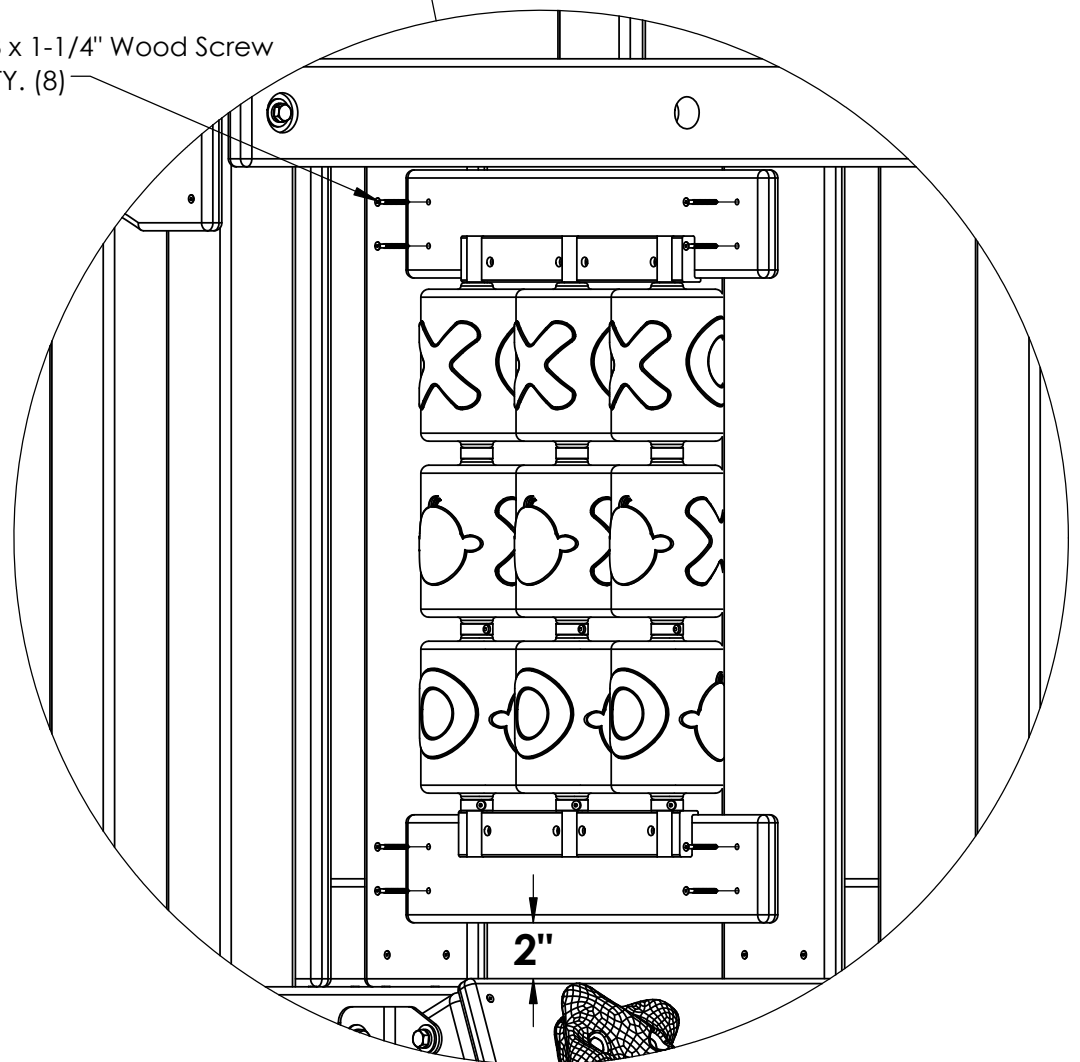

## STEP 36: STEERING WHEEL

1: DRILL AN 11/64" HOLE 2" DEEP INTO THE END OF THE SWING BEAM.

2: USE THE HARDWARE INCLUDED WITH THE STEERING WHEEL TO MOUNT THE STEERING WHEEL TO THE END OF THE SWING BEAM.

**\*\* DO NOT OVER-TIGHTEN THE LAG SCREW INTO THE STEERING WHEEL, OR IT WILL NOT TURN \*\***

3: SNAP THE STEERING WHEEL CAP INTO THE STEERING WHEEL INSERT.

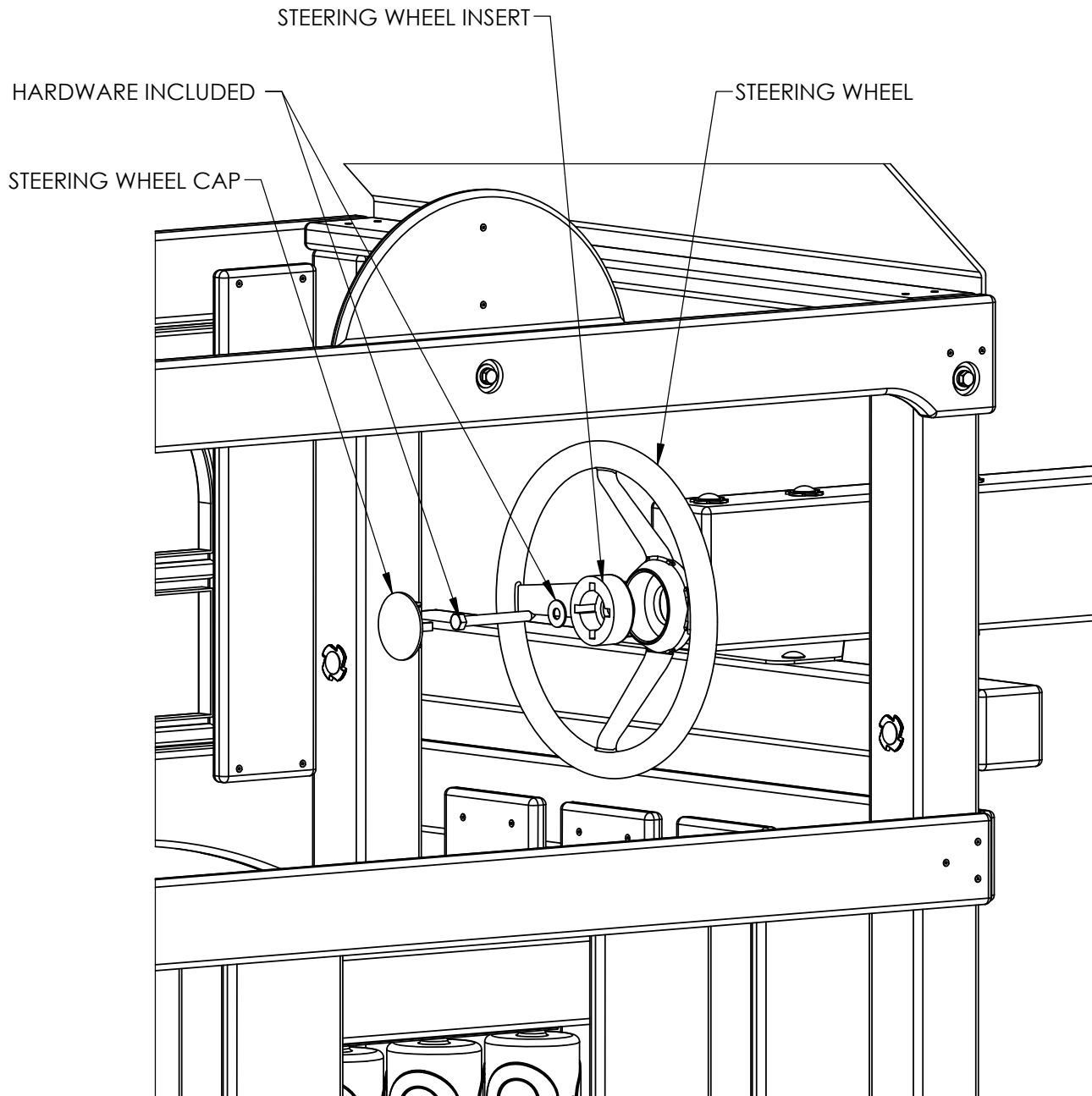

## STEP 37: CHALKBOARD

1: ATTACH CHALKBOARD TO THE SLATS UNDER STEERING WHEEL.

NOTE: CHALKBOARD COMES WITH A MAGNETIC CHALK HOLDER WHICH WILL STICK TO THE CHALKBOARD.

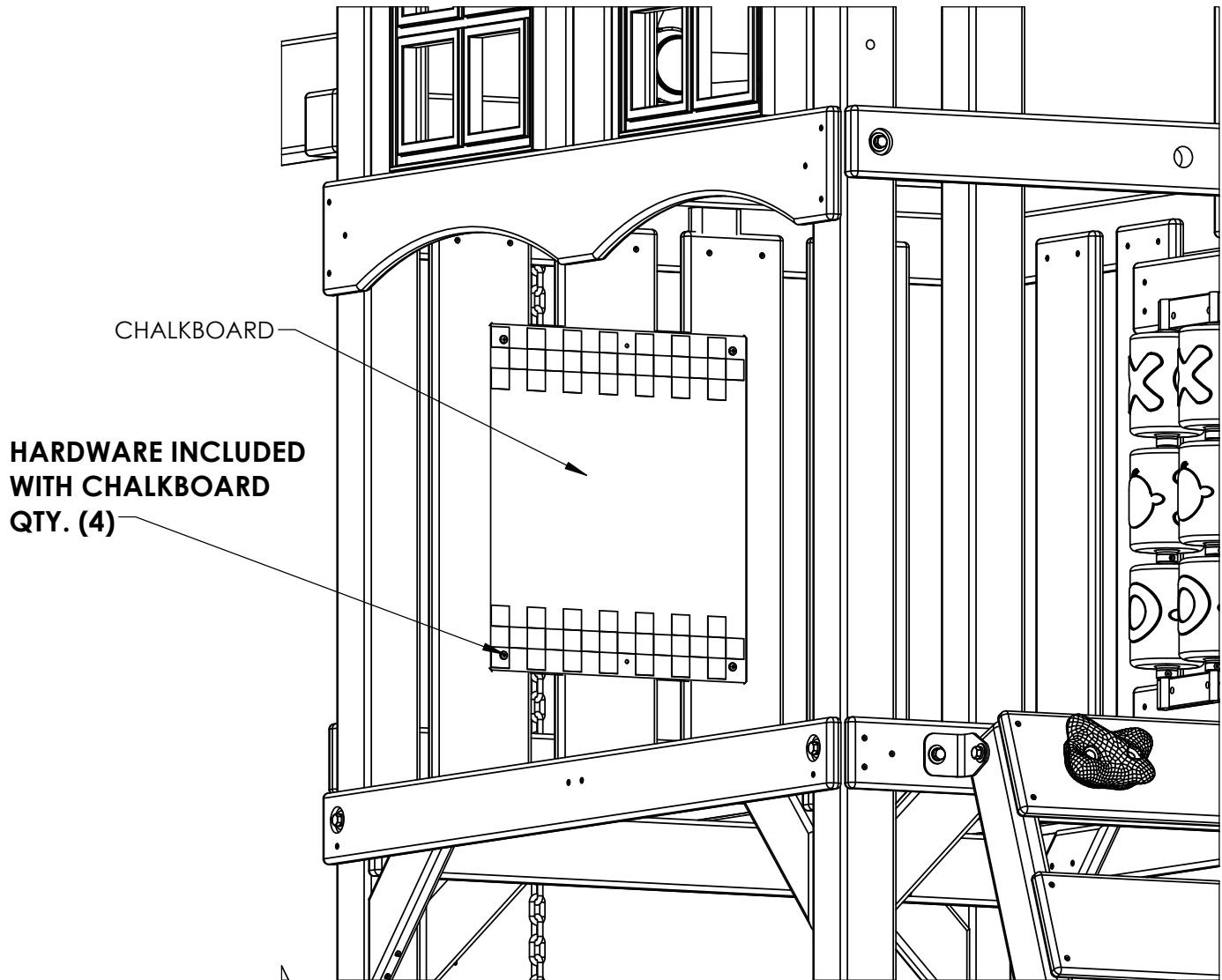

## STEP 38: CLIMBING ROPE

1: THREAD ROPE AS SHOWN IN THE DIAGRAM BELOW.

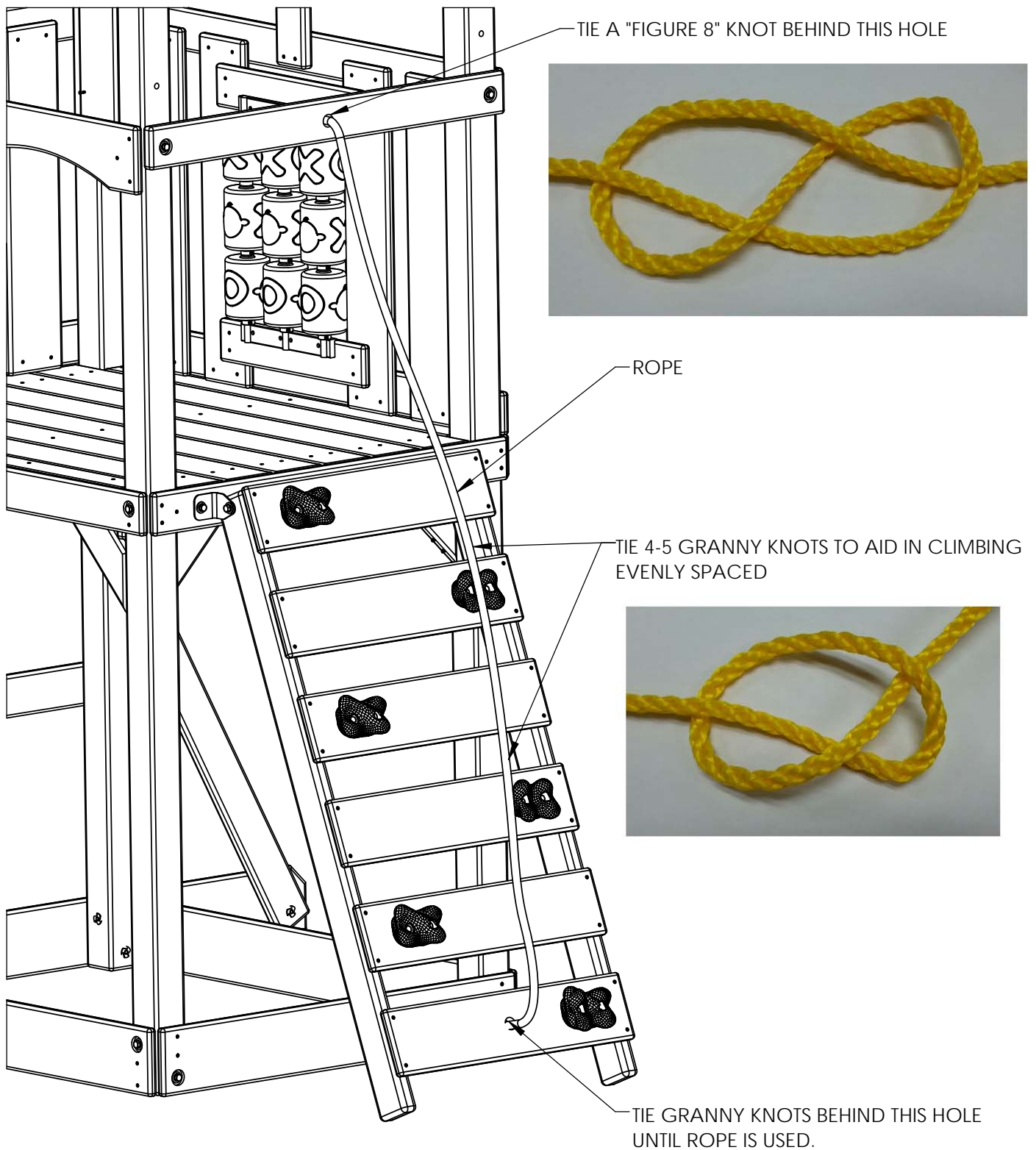

**FOR SAFETY, ENSURE THAT THE ROPE IS TIGHT ENOUGH SO THAT IT CAN NOT BE LOOPED BACK ON ITSELF.**

KEEP TYING GRANNY KNOTS AT THE BOTTOM END OF ROPE UNTIL THERE IS NO REMAINING LOOSE ROPE.

**DO NOT CUT ENDS OF ROPE.**

## STEP 39: FLAG KITS

1: INSTALL THE FLAG KITS ON THE CORNER POSTS AT THE FRONT OF THE FORT. ATTACH THE FLAG KITS WITH THE HARDWARE PROVIDED.



## STEP 40: SLIDE BLOCK

1: PLACE SLIDE BLOCK UNDERNEATH THE DECK SPACER AGAINST THE ANGLE SUPPORT. SEE DIAGRAM BELOW.

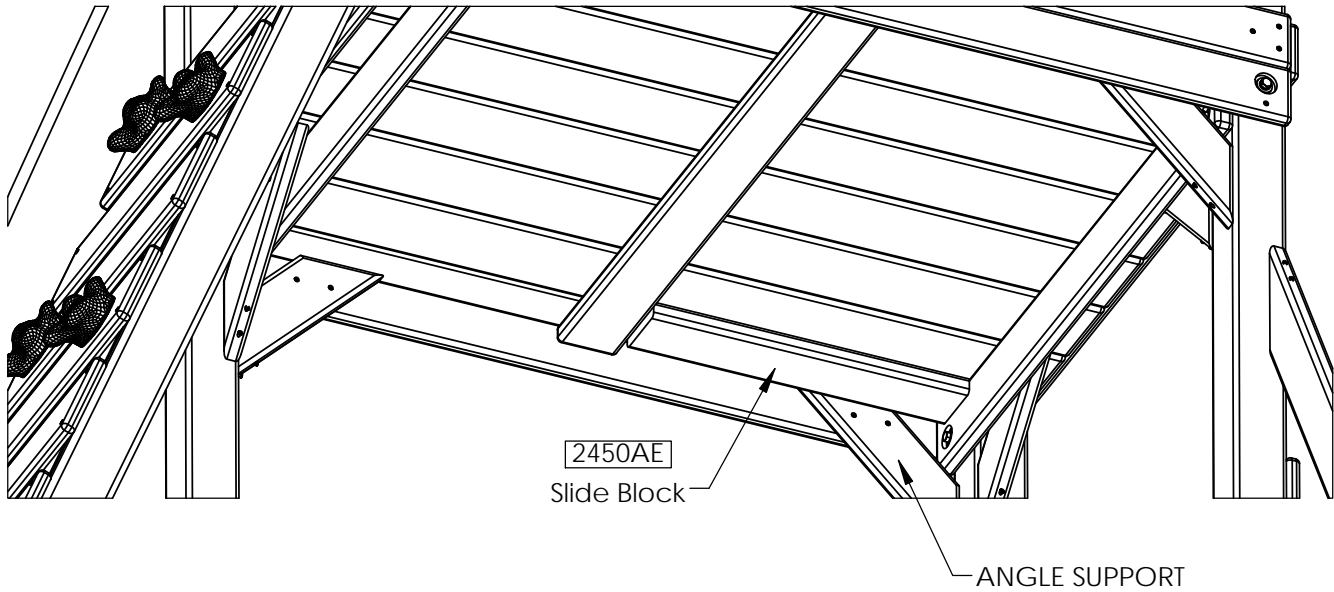

2: FASTEN THE SLIDE BLOCK FROM THE TOP OF THE DECK SPACER.

**NOTE: PRE-DRILL 1/8" HOLES TO HELP AVOID SPLITTING.**

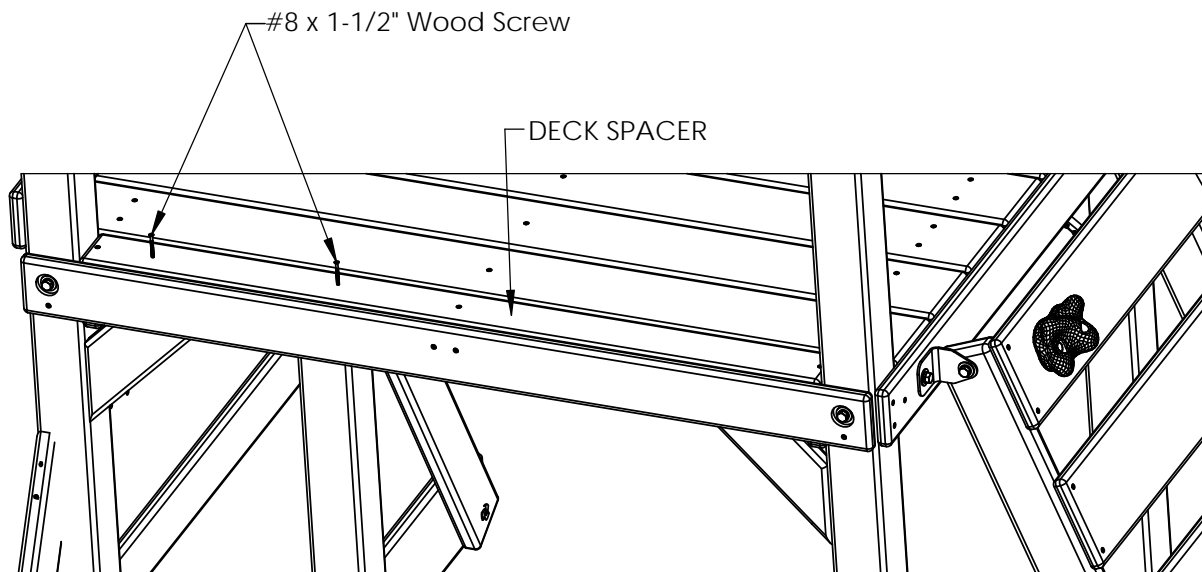

# STEP 41: SAFETY HANDLES

1: ATTACH EACH SAFETY HANDLE TO THE CORNER POST WITH THE HARDWARE PROVIDED.

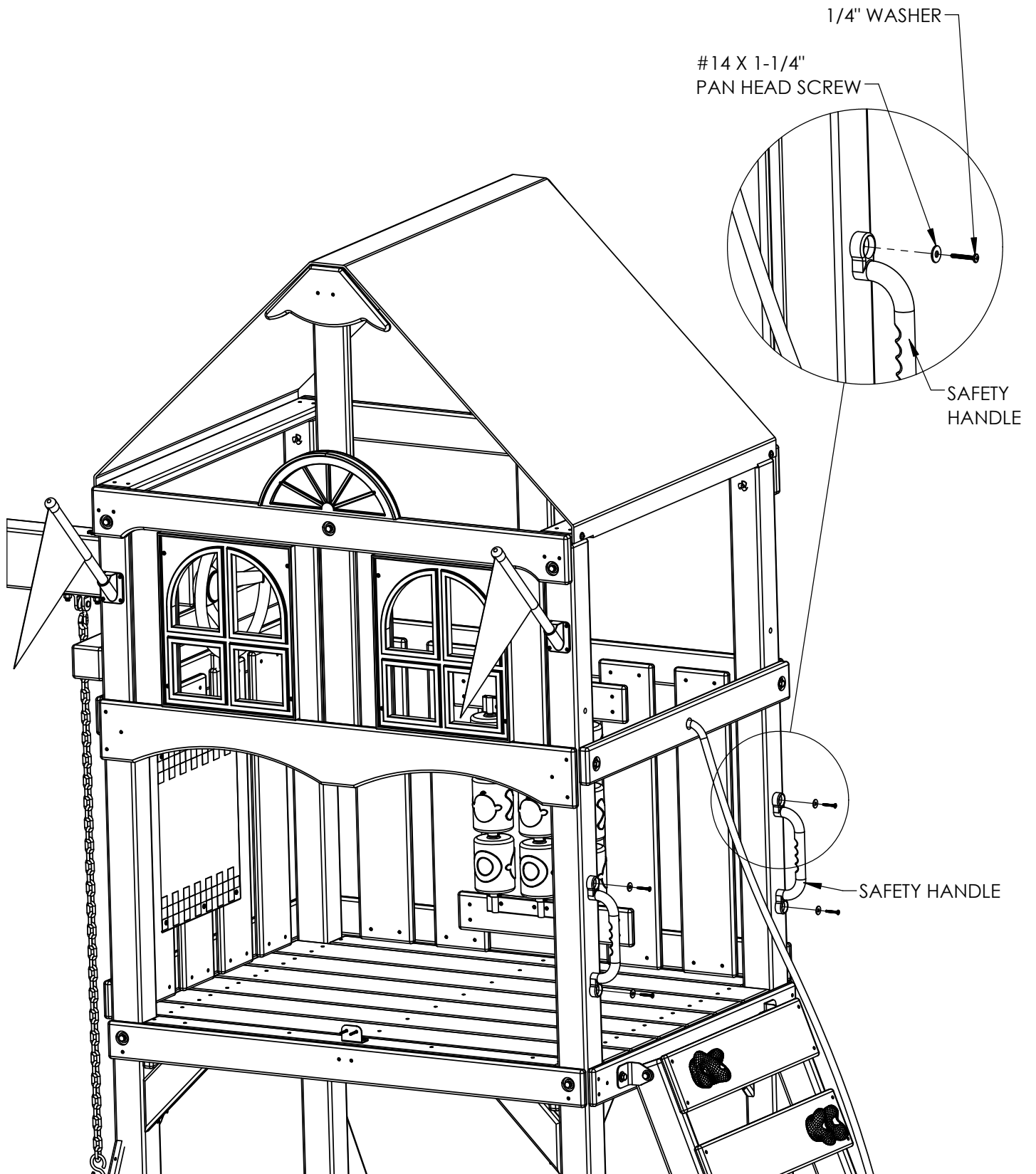



# STEP 42: BOTTOM PANEL BOARD

1: PLACE THE BOTTOM PANEL BOARD ON TOP OF THE FRONT FACE BOARD AS SHOWN BELOW.

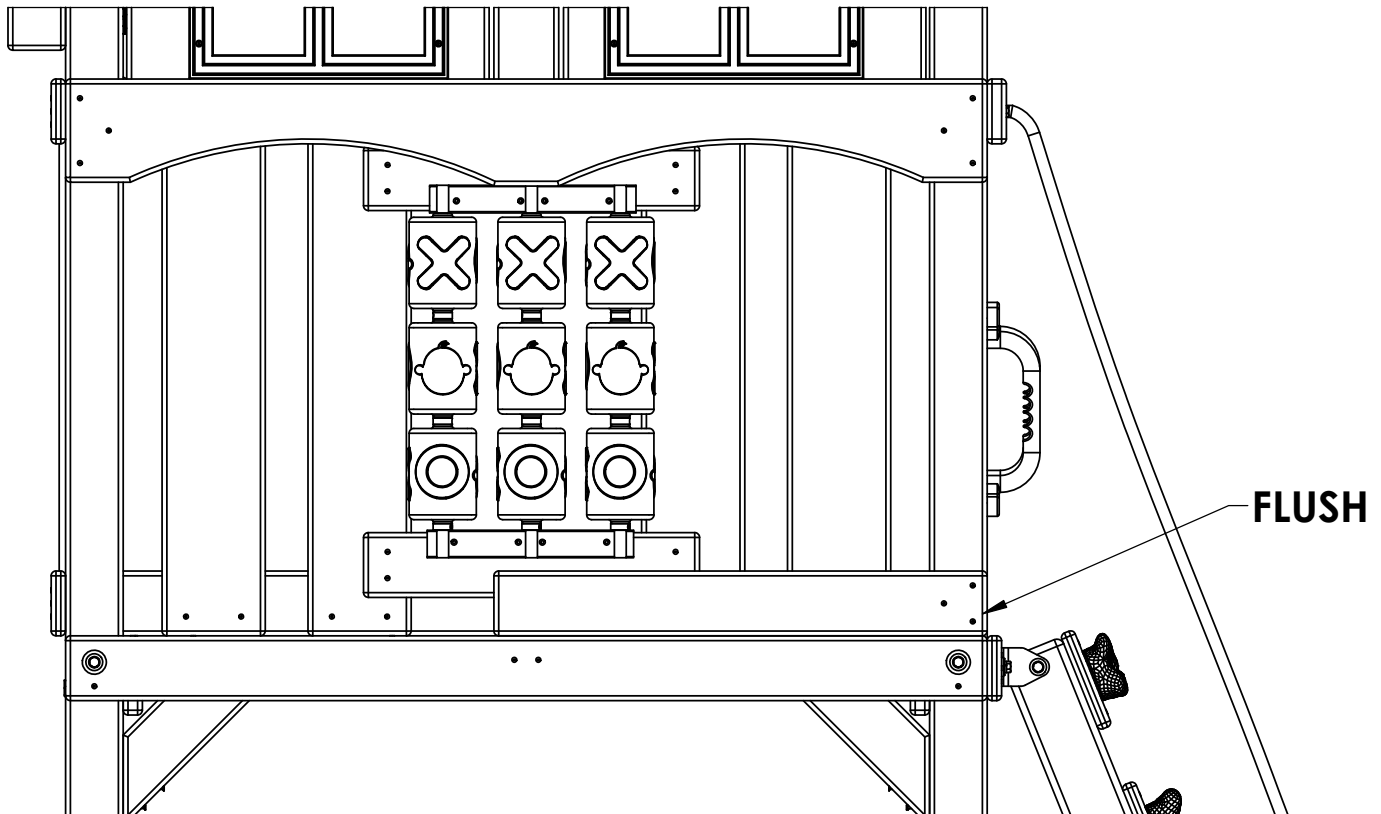
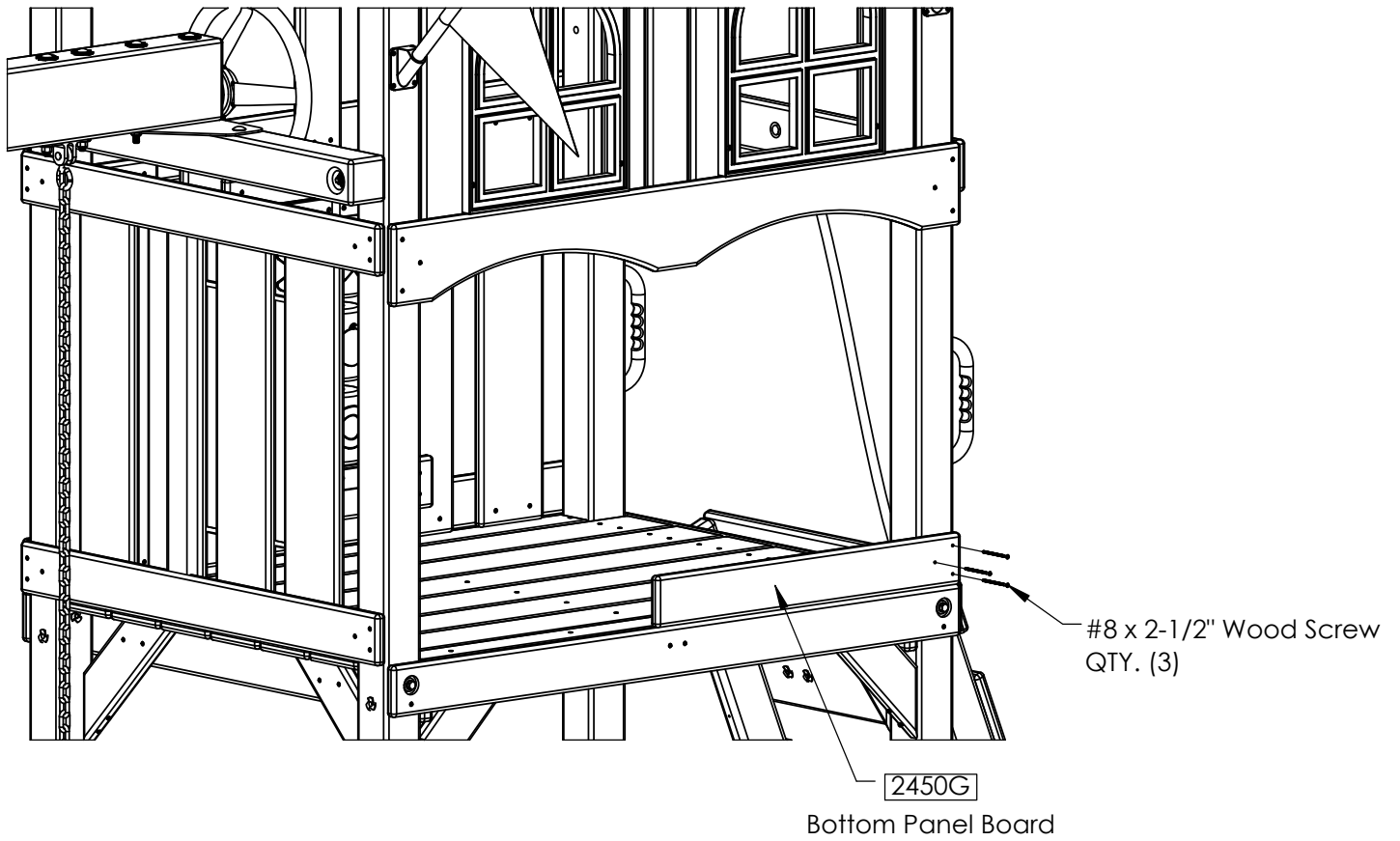

# STEP 43: PANEL SLATS

1: ATTACH ALL PARTS IN THE ORDER SHOWN BELOW.

**NOTE ORDER OF INSTALLATION.**

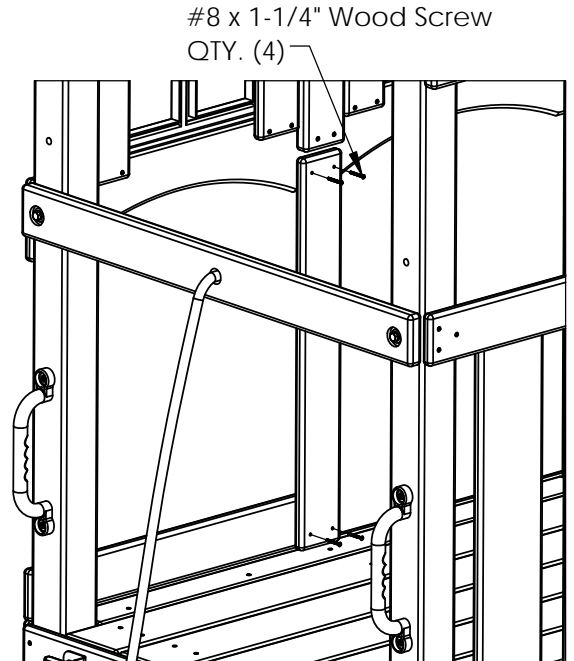
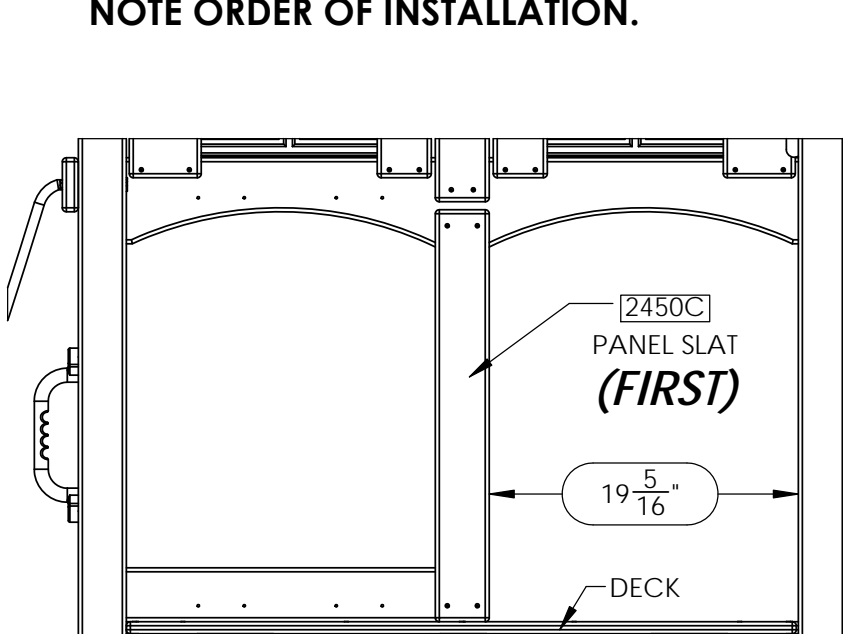

2: ATTACH PANEL BRACKET AS SHOWN IN THE DIAGRAM.

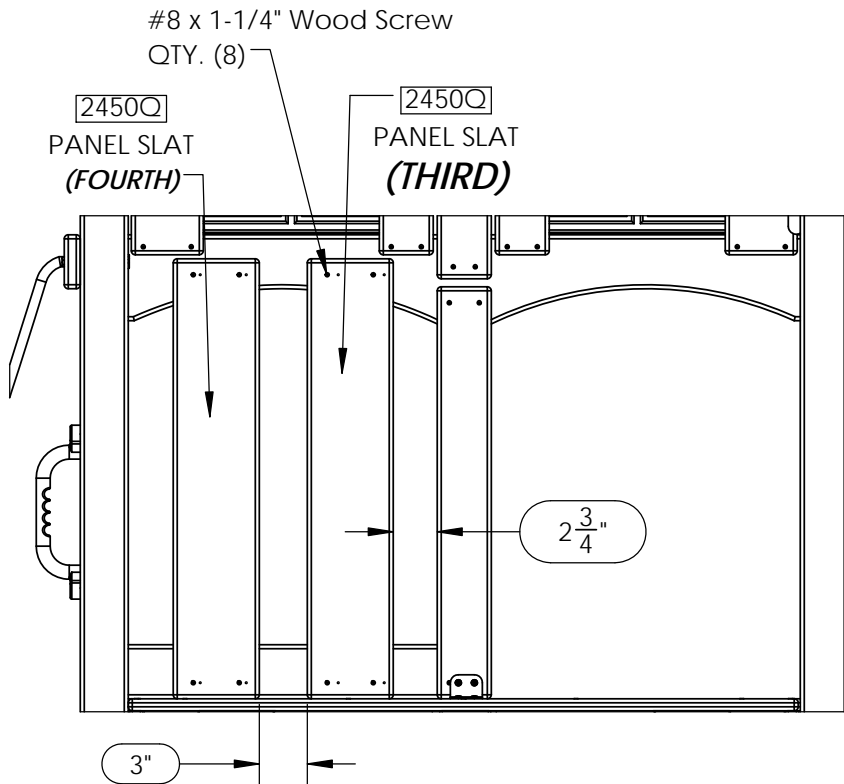
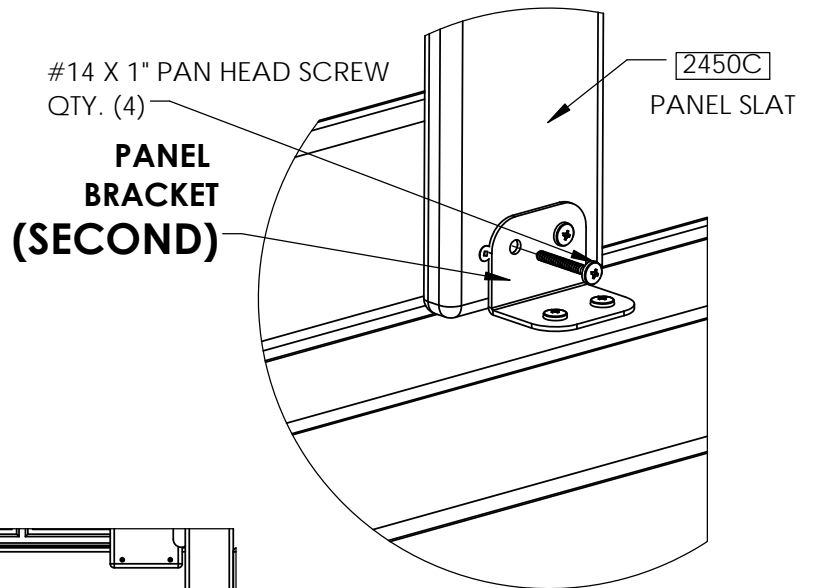

## STEP 44: INSTALLING THE SLIDE

1: PLACE THE SLIDE CENTERED IN THE OPENING. LAY THE SLIDE ON THE DECK WITH THE LIP EXTENDING ONTO THE DECK.

#14 X 1-1/4" TRUSS HEAD SCREWS  
(HARDWARE PROVIDED WITH SLIDE)

**\*DO NOT OVER TIGHTEN\***

YOU MAY DRILL 1/8" PILOT  
HOLES THROUGH THE CENTER  
OF EACH DIMPLE FOR THE  
SCREWS.

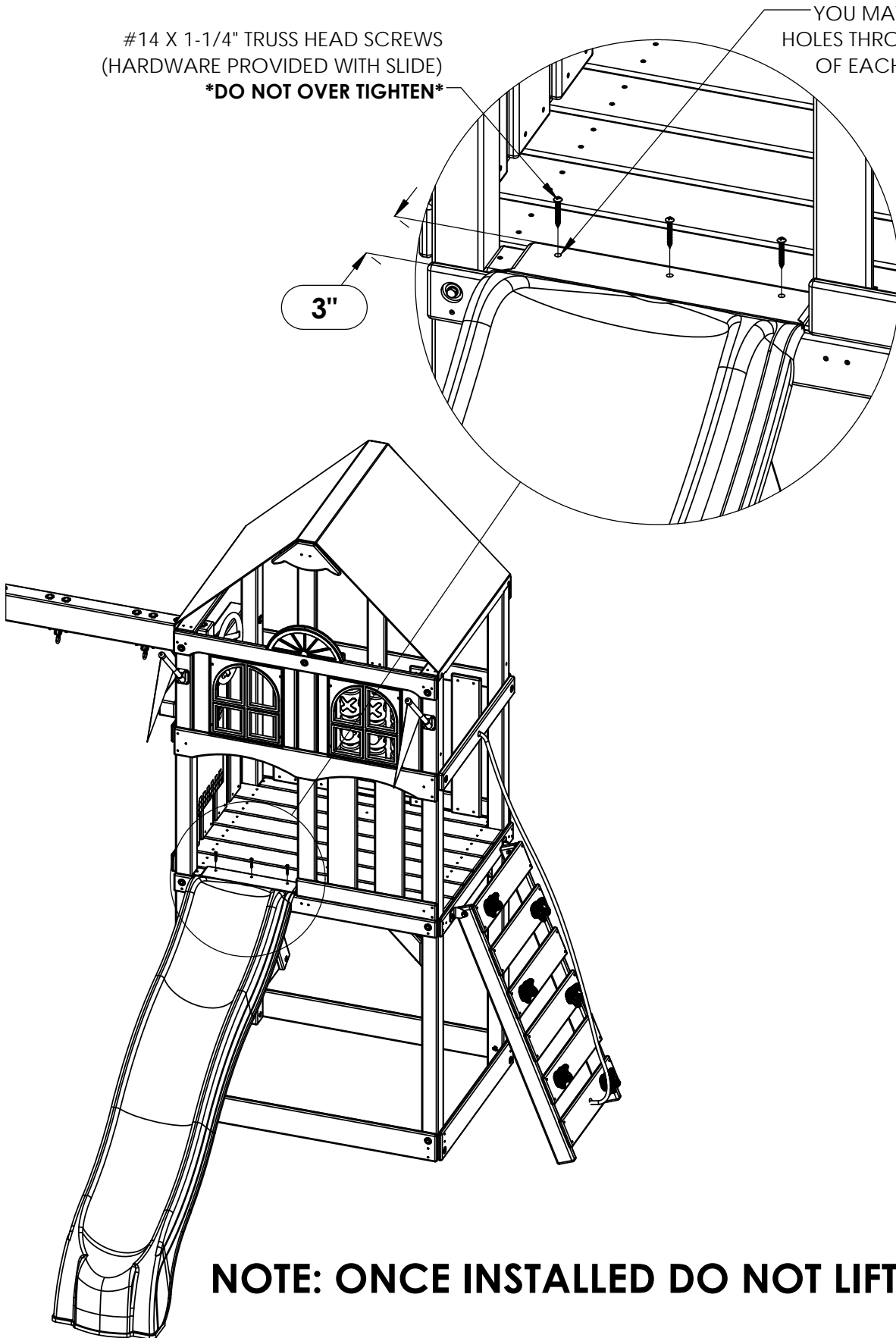

## STEP 45: SWINGS AND NAME PLATE

1: ATTACH SWINGS AND TRAPEZE TO SWING BEAM AS SHOWN BELOW.

**\*\* EXCESS CHAIN MAY BE LOOPED AND HOOKED ONTO THE END OF THE SWING HANGER HOOK \*\***

2: ATTACH THE NAME PLATE TO THE MIDDLE OF THE SWING BEAM WITH TWO 1-1/4" WOOD SCREWS.

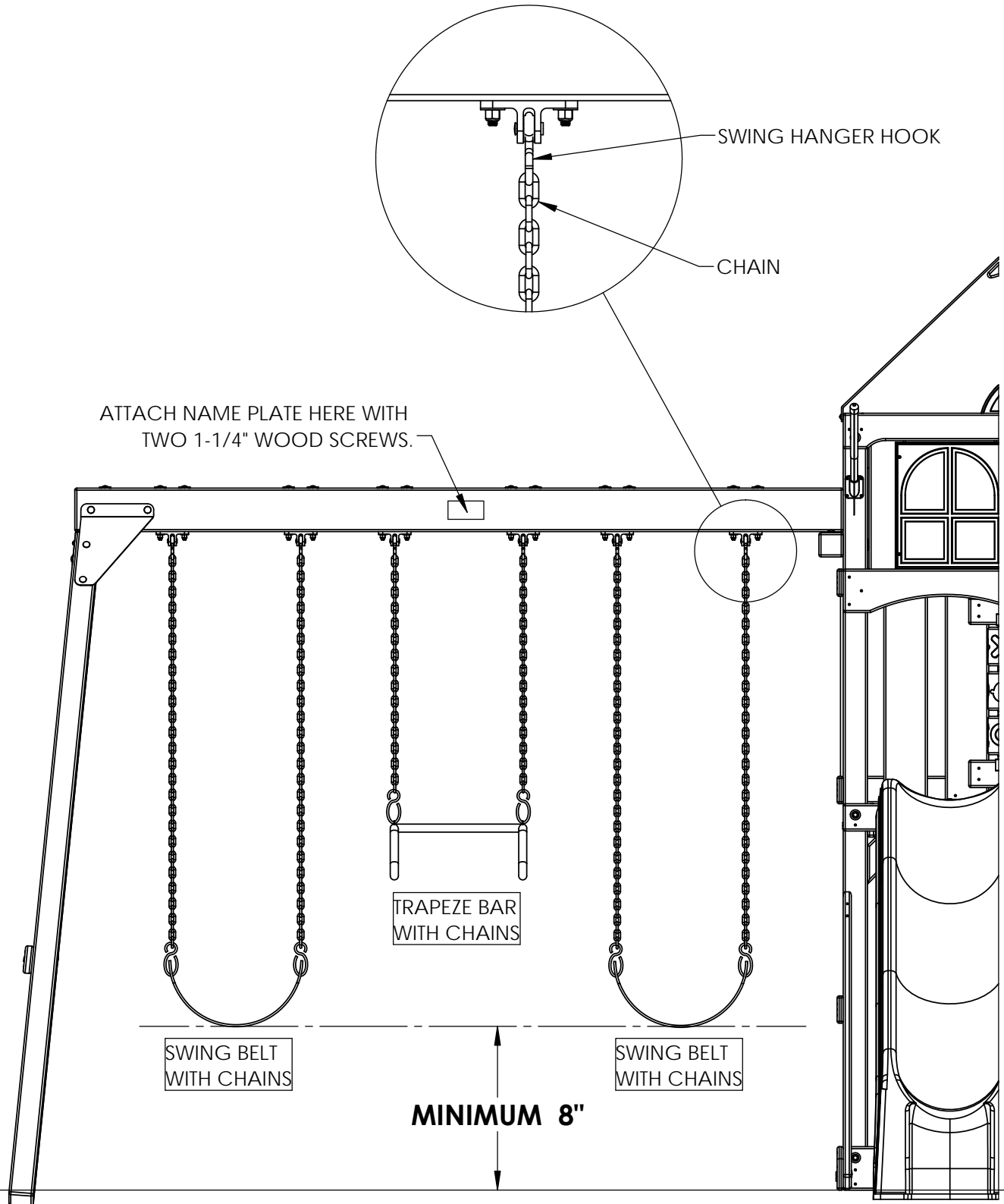

## STEP 46: PERISCOPE

1: FASTEN THE PERISCOPE BRACKET TO THE SLAT WITH HARDWARE PROVIDED IN THE KIT.

2: SNAP THE PERISCOPE INTO THE PERISCOPE BRACKET. THE PERISCOPE BRACKET SHOULD BE IN BETWEEN THE "RINGS" AT THE BOTTOM OF THE PERISCOPE.

**!WARNING! \*\*DO NOT LOOK INTO SUN OR OTHER BRIGHT LIGHTS WITH PERISCOPE\*\***

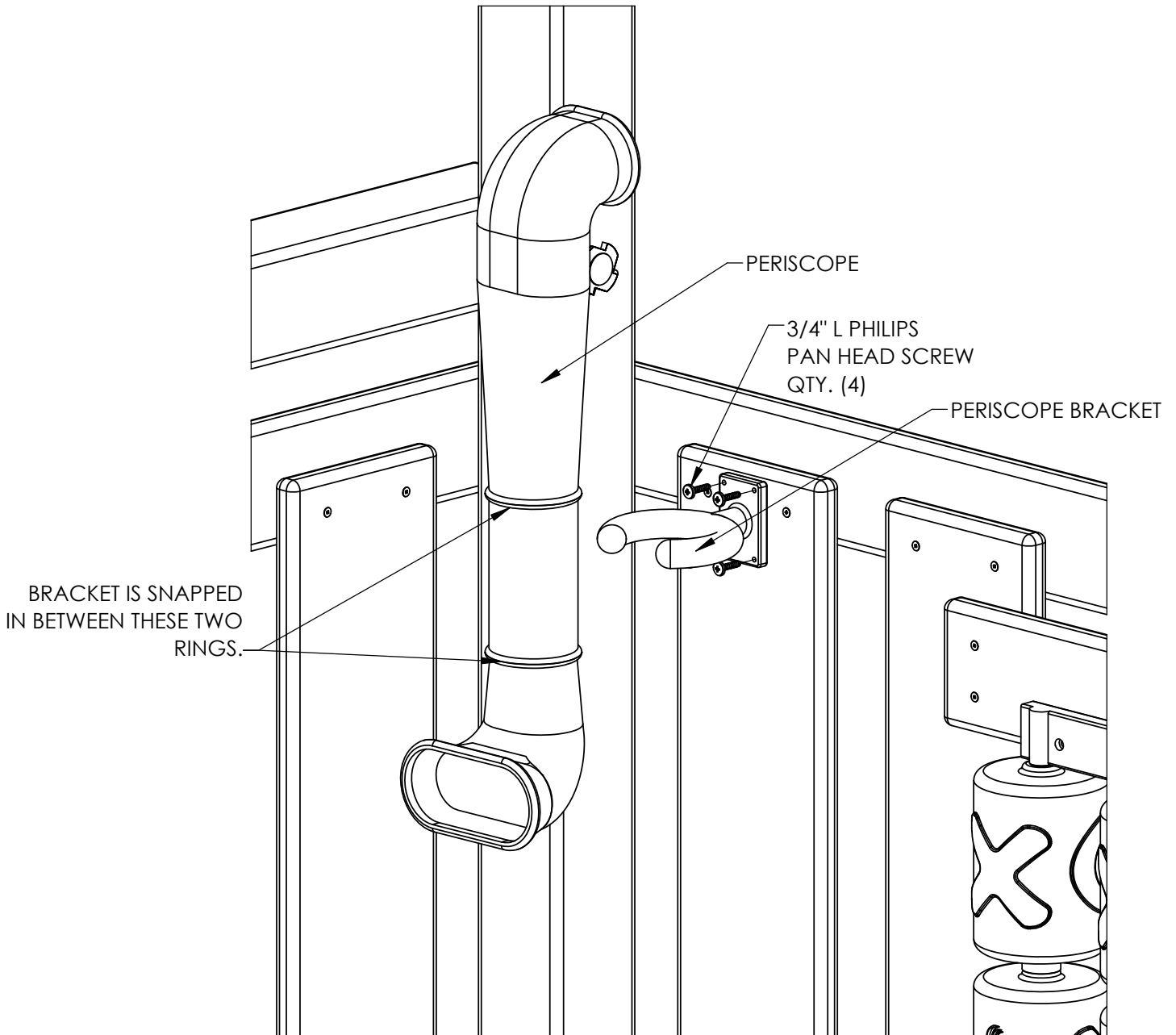

# STEP 47: TELESCOPE

1: ATTACH TELESCOPE AS SHOWN BELOW.

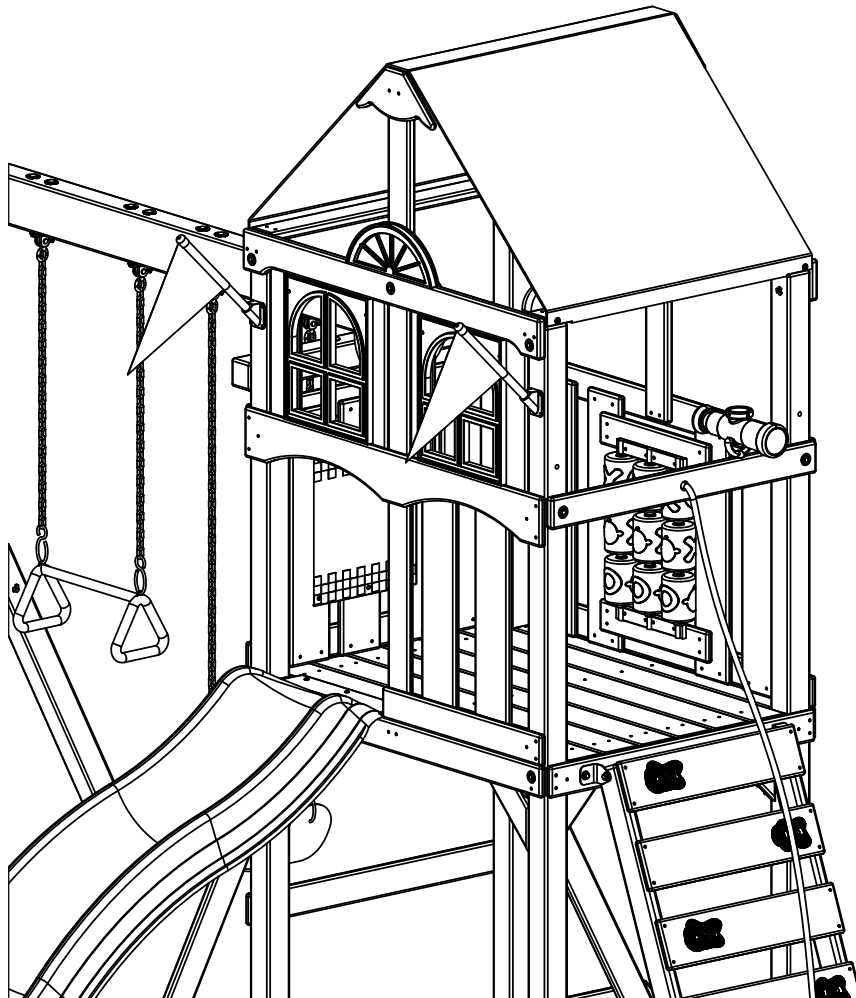
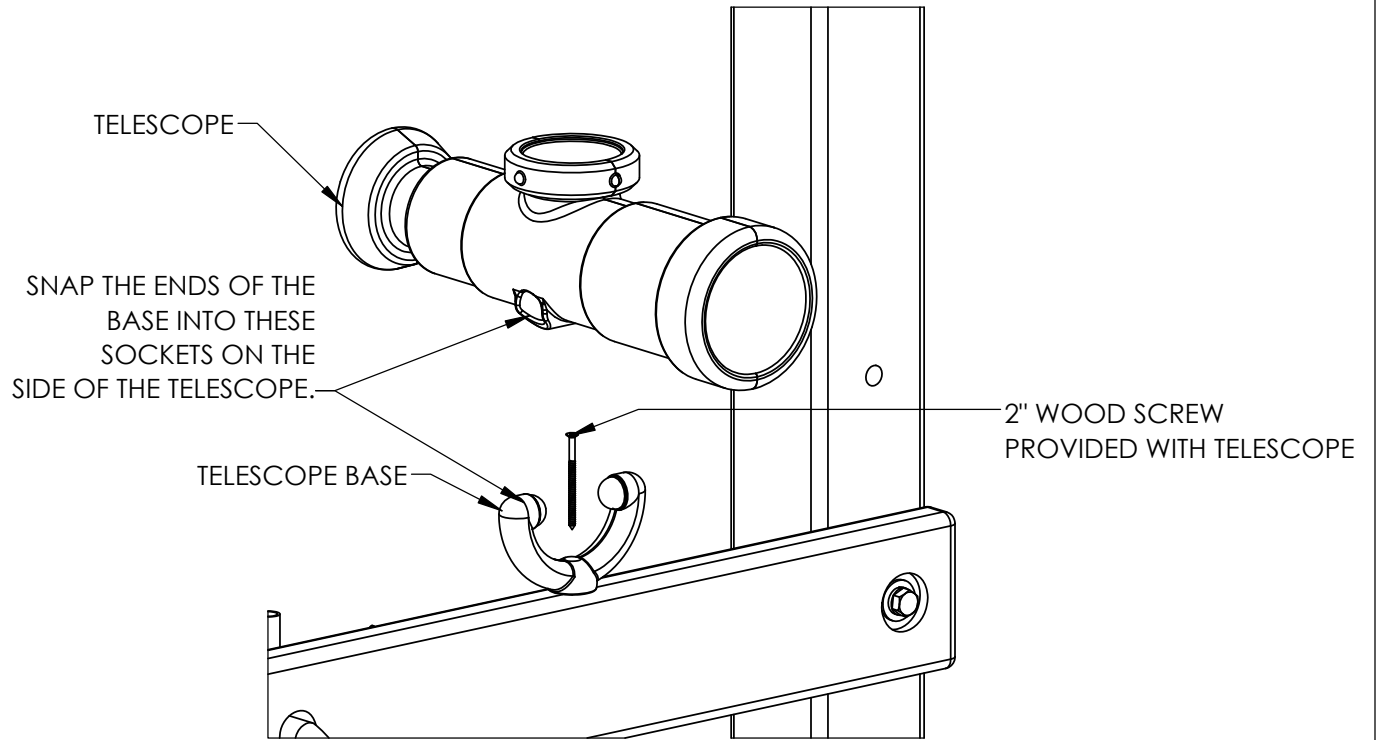

## STEP 48: GROUND STAKES

1: ATTACH EACH GROUND STAKE WITH THE HARDWARE PROVIDED WITH KIT.

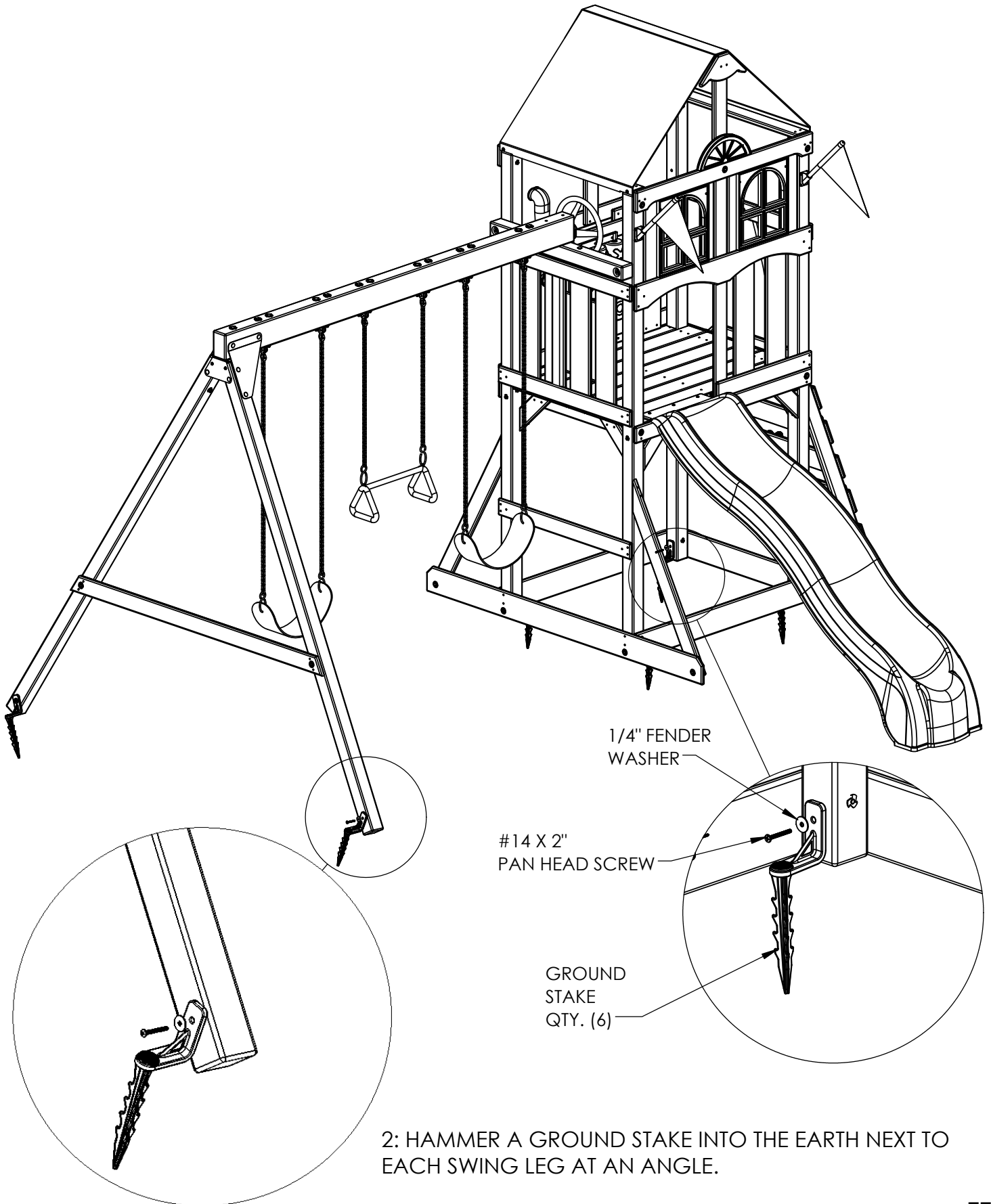

# STEP 49: SANDBOX SEATS

1: INSTALL BOARDS AS SHOWN BELOW.

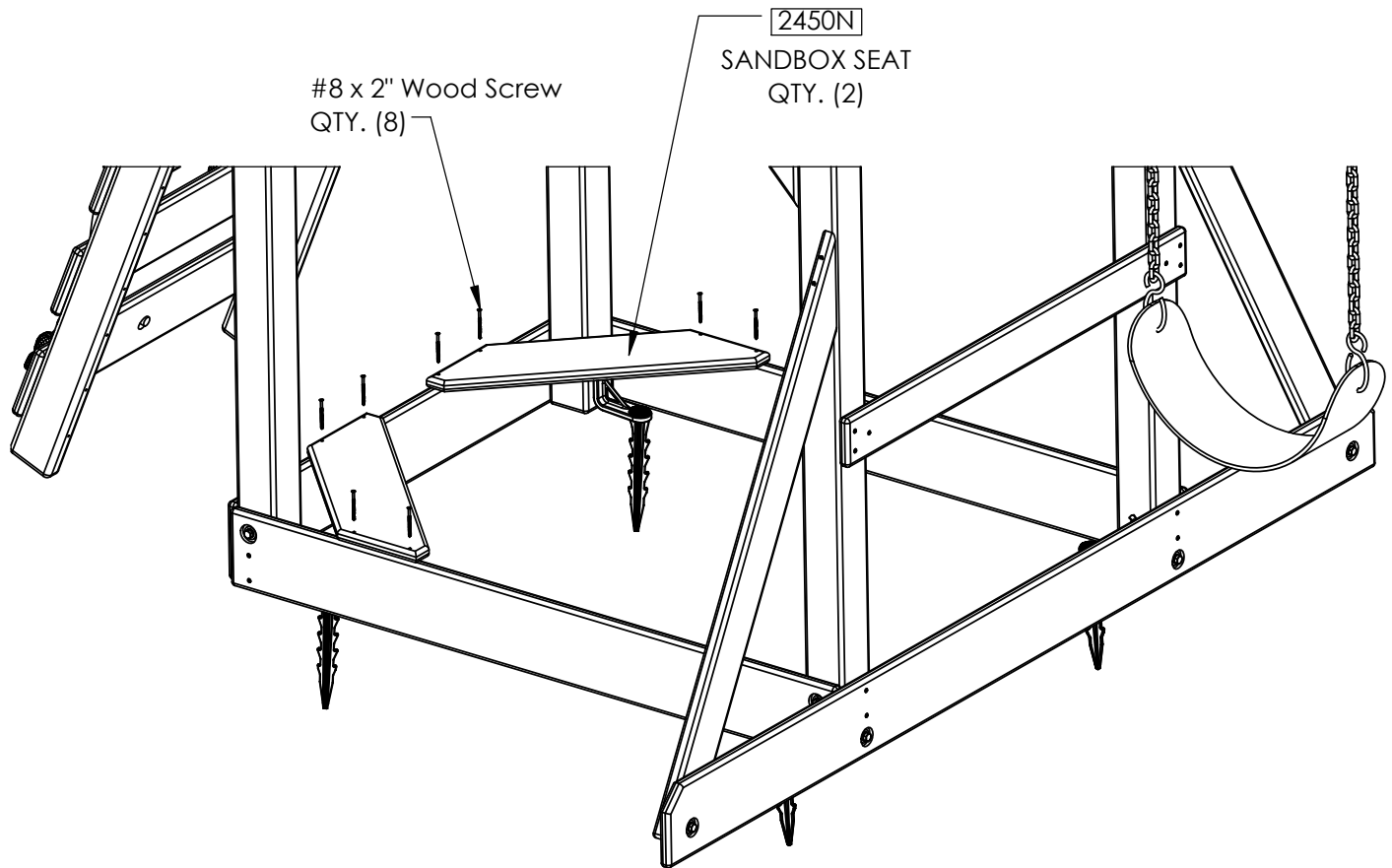



## 2450 Hardware Running Change

### Notice:

Due to a running change to the 2450 hardware kit you may have the following parts leftover upon completion of your playset:

5/16" x 3-3/4" Hex Bolt – 12 not used

#14 x 1-1/2" Pan Head Screw – 3 not used