



Royal Clubhouse Deluxe

ASSEMBLY MANUAL

Copyright © 2012 PlayNation Play Systems, Inc.

All Rights Reserved

www.PlayNation.com • 190 Etowah Industrial Court • Canton, GA 30114 • (800) 661-7295

Latest Revision: April 11, 2012

TABLE OF CONTENTS

Warranty and Safety Guidelines.....	Pages 3-10
Leveling Play Set, General Information and Definitions.....	Pages 10-12
Site Plan, Tool List and Kit Contents.....	Pages 13-14
Hardware, Lumber and Accessory Checklist.....	Pages 15-24
Framing Fort.....	Steps 1-7
Attaching Deck Board Panels and Deck Spacers.....	Steps 8-9
Attaching Side Wall Panels (Lower Level).....	Step 10
Attaching Side Panel (Upper Level).....	Step 11
Attaching Door Wall Panel (Lower Level).....	Step 12
Attaching Post Panel and Swing Beam Side Panel (Upper Level).....	Steps 13-14
Attaching Railing (Lower Level).....	Step 15
Attaching Ladder and Safety Board.....	Step 16
Attaching Tarp Boards.....	Step 17
Attaching Rope Ladder Support and Rope Ladder.....	Steps 18-19
Swing Beam Assembly.....	Steps 20-26
Hanging Swings.....	Step 27
Attaching Tarp (Canopy).....	Step 28
Dinner Bell, Telescope, Flags, Name Plate.....	Steps 29-31
Steering Wheel and Scoop Slide.....	Steps 32-33
Warranty Registration Card.....	Last Page

**PLEASE READ OWNER'S MANUAL CAREFULLY
BEFORE STARTING ASSEMBLY!**

IMPORTANT – PLEASE READ

As fresh lumber acclimates to its new environment, the natural tendencies of the tree can show itself in the form of checks, or “cracks” in the lumber. In almost all cases this is normal and it will not affect the structural integrity of your play set.

Cosmetic defects that do not affect the structural integrity of the product, or natural defects of wood such as warping, checking or any other physical properties of wood that do not present a safety hazard, are not covered by this warranty. Defects that develop because the product is exposed to extreme climate conditions are not covered by this warranty. Defects that develop as a result of faulty or improper installation of the product are also not covered by this warranty.

Most cracks are not warrantable, however if you believe that the integrity of your play set is compromised by this natural occurrence, please follow the warranty claim procedure found at www.playnation.com. Click on the “Customer Care” tab on the left hand side of the page, then click on “Warranty Claim” and follow the instructions.

We appreciate your purchase and know that you will enjoy your play system for many years to come.

IF YOU HAVE MISSING OR DAMAGED PARTS OR NEED ASSISTANCE ASSEMBLING, PLEASE CALL PlayNation Play Systems, Inc. MANUFACTURING DIRECT.(800) 445-7529 FACTORY HOURS – MON.–FRI., 8AM-5PM EST DO NOT RETURN THIS PRODUCT TO THE RETAILER OR CONTACT THE RETAILER DIRECT. THE RETAILER DOES NOT STOCK COMPONENTS. PLEASE RETAIN THESE INSTRUCTIONS FOR FUTURE REFERENCE. KEEP THEM IN A SAFE PLACE WHERE YOU CAN REFER TO THEM AS NEEDED.

CONTACT INFO:

PlayNation Play Systems, Inc.
190 Etowah Industrial Court
Canton, GA 30114
Tel. (770) 704-9300
Fax. (678) 880-3300
custsrv@playnation.com

Check for revised instructions at www.playnation.com/instructions.html

Thank you for choosing PlayNation Play Systems, Inc.

We've included everything you need, except tools, to build your very own professional looking play set. When complete, your new play set should far exceed the quality of play set kits from other build-your-own companies. Our engineers and design team have over 30 years of playground experience. What we've developed is a play set that doesn't compromise quality for simplicity. Yet you'll appreciate how quick and easy construction really is! Our play set kits are designed for children ages 3 to 11. PlayNation Play Systems, Inc. believes every child should have a play set and with our kits they can! You can rest assured your new play set is safe, durable and designed to hold up to the elements. As parents ourselves, we know how important the security and well-being of our children is, and this shows in all of our products.

Each play set features our step-by-step 3D illustrated manual, patented powder coated swing beam bracket, heavy-duty swing belts with chains, slide(s), accessories, plus all the required hardware and pre-milled lumber.

Limited Manufacturers Warranty

PlayNation Play Systems, Inc. (“PlayNation”) warrants its play sets to be free from defects in workmanship and materials, under normal use and conditions at its original installation, for the lifetime of the product for structural wood components and for two years for all other components (e.g., hardware, plastics, tarps, rope ladder, etc.) except PlayNation’s Super Scoop Slides™ and Super Tube Spiral Slides™.

PlayNation warrants its Super Scoop Slides™ and Super Tube Spiral Slides™ to be free from defects in workmanship and materials, under normal use and conditions, for the lifetime of the product.

Cosmetic defects or natural defects of wood (e.g., warping, seasonal checking or cracking, knots, or knot holes, etc.) that do not affect the structural integrity of the product are not covered by this warranty. Defects that develop because the product is exposed to extreme climate conditions, excessive water exposure, lumber that has been damaged by wood boring bees, or defects that develop as a result of faulty or improper installation of the product, are not covered by this warranty. Fading or discoloration or molding of any wood part or accessory, cracks in plastic components, surface rust on hardware, and chips on powder coated materials are not considered defects in material as long as they do not affect the functionality or structural integrity of the part or component.

It is the owner’s responsibility to properly maintain the play set. Instructions for proper maintenance can be found on PlayNation’s website. Imperfections or defects that develop because of a failure to properly maintain the play set are not covered by this warranty.

PlayNation will repair or, at its discretion, replace any part within the stated warranty period that is defective in workmanship or materials. This decision is subject to verification of the defect, which, at PlayNation’s discretion, may be accomplished by submitting photographs or by delivery of the defective part to PlayNation. Any warranty claim must include proof of purchase, including the date of purchase. In addition, within the first 30 days from the date of purchase, PlayNation will replace any parts discovered to be missing from or damaged in the original packaging.

This warranty is valid only if the product is used for the purpose for which it was designed and installed at a residential, single-family dwelling. This warranty is void if the product is used in a commercial or institutional setting. This warranty does not cover (a) products that have been damaged by acts of God, negligence, misuse, or accident, or that have been modified or repaired by unauthorized persons; (b) the cost of labor; or (c) the cost of shipping the product, any part, or any replacement product or part.

PLAYNATION DISCLAIMS ALL OTHER REPRESENTATIONS AND WARRANTIES OF ANY KIND, EXPRESS, IMPLIED, STATUTORY, OR OTHERWISE, INCLUDING THE IMPLIED WARRANTIES OF MERCHANTABILITY AND FITNESS FOR A PARTICULAR PURPOSE. PLAYNATION WILL NOT BE LIABLE FOR ANY INCIDENTAL OR CONSEQUENTIAL DAMAGES. This warranty is valid only in the United States of America, is nontransferable and does not extend to the owners of the product subsequent to the original purchaser. Some states do not allow limitations on implied warranties or exclusion of incidental or consequential damages, so these restrictions may not be applicable to you. This warranty gives you specific legal rights. You may also have other rights which vary from state to state.

Important Safety Guidelines

This product is intended for residential use only and not intended for use in any public setting. A safety surface such as mulch or recycled tire should be used under the play set to prevent injury from falls. Also a 6 foot safety zone should be used around the entire play set.

As with any home project, good judgment and respect for power tools will greatly reduce the risk of injury. PlayNation recommends you follow all tool manufacturers' safety guidelines. Always wear eye protection and safety gloves to prevent injury. In several phases of construction two people may be required for lifting and securing of lumber. While play set is being constructed, please keep children off the equipment until the project is complete. Bolts and screw heads should be checked regularly for tightness. The ground ladder, rope ladder, slide, swings and other areas where children spend a majority of their playtime should be checked more frequently.

PlayNation shall not be liable for incidental, indirect or consequential damages or injuries that result from the building and/or playing on our play sets. Adult supervision is recommended anytime a play set is being used.

WEIGHT LIMITS FOR PlayNation Play Systems

- FORT PLATFORMS: 800 LBS. TOTAL WEIGHT
- SWING BELTS: 225 LBS.
- GLIDER SWINGS: 70 LBS. PER CHILD. UP TO 140 LBS. TOTAL WEIGHT.
- TRAPEZE: 125 LBS.
- FULL BUCKET SWING: 50 LBS.
- HALF BUCKET SWING: 50 LBS.
- INFANT SWING: 35 LBS.
- TIRE SWING: 125 LBS. TOTAL WEIGHT
- ROPE LADDER: 75 LBS.
- ROCK WALL: 150 LBS.
- SUPER SCOOP SLIDE: 250 LBS.

PlayNation recommends that the weight limits for all components must not be exceeded. Failure to adhere to these and other safety guidelines could result in damage to the play set and injury to the users.

Safety and Maintenance Tips for Your New Play Set:

NOTE: Your children's safety is our #1 concern. Observing the following statements and warnings reduces the likelihood of serious or fatal injury. Please review these safety rules regularly with your children.

- This play set is designed for the use of 4 occupants who have a combined weight not exceeding 800 pounds on the elevated floor, 3 occupants who have a combined weight of 525 pounds on the swing area, for a total unit capacity of 7 occupants who have a combined weight of 1325. (this weight is not including the picnic table area)
- On-site adult supervision is required.
- Teach children not to walk close to, in front of, behind, or between moving swings or other moving playground equipment.
- Teach children to sit in and never stand on swings.
- Teach children not to twist the chains and ropes and not to loop them over the swing beam, since this may reduce the strength of the chain or rope.
- Teach children not to jump from swings or other playground equipment in motion.
- Teach children not to push empty seats. The seat may hit them and cause serious injury.
- Teach children to sit in the center of the swings with their full weight on the seats.
- Teach children not to use the equipment in a manner other than intended.
- Teach children to always go down slides feet first. Never slide headfirst.
- Teach children to look before they slide to make sure no one is at the bottom.
- Teach children to never run up a slide, as this increases their chances of falling.
- Parents should have children dress appropriately with well-fitting shoes. Loose clothing such as scarves and ponchos should not be worn. Always take off, tie up or tuck in cords and drawstrings on children's clothing. These things can get caught on playground equipment and strangle a child.
- Teach children not to climb when the equipment is wet.
- Teach children to never jump from a fort deck. They should always use the ladder, ramp or slide.
- Teach children to never crawl or walk across the top of monkey bars.
- Teach children to never crawl on top of a fort roof.
- Verify that any suspended climbing ropes, chains, or cables are secured at both ends.
- Verify climbing ropes are tight enough that they cannot be wrapped around an adult hand.
- Teach children not to attach items to the playground equipment that are not specifically designed for use with the equipment, such as, but not limited to, jump ropes, clothesline, pet leashes, cables and chain as they may cause a strangulation hazard.
- Teach children to never wrap their legs around swing chain.
- Teach children to never slide down the swing chain.

WARNING: Children must NOT use this play set until unit has been completely assembled and inspected by an adult to insure set has been properly installed.

Safety and Maintenance Tips for Your New Play Set: (continued)

Playgrounds should be inspected on a regular basis. If any of the following conditions are noted, they should be removed, corrected, or repaired immediately to prevent injuries.

- Hardware that is loose, worn or that has protrusions or projections.
- Exposed equipment footings.
- Scattered debris, litter, rocks, or tree roots.
- Splinters, large cracks, and decayed wood components.
- Deterioration and corrosion on structural components, which connect to the ground.
- Missing or damaged equipment components, such as handholds, guardrails, swing seats.
- Check all nuts and bolts frequently during the usage season and tighten as required. (But not so tight that you crack the wood) We recommend you check the swing beam and hardware often due to wood expansion and contraction. It is particularly important that this procedure be followed at the beginning of each season.
- Remove plastic swing seats and take indoors or do not use when the temperature drops below 32°F.
- Oil all metallic moving parts monthly during the usage period.
- Check all coverings for bolts and sharp edges twice monthly during usage season to be certain they are in place. Replace when necessary. It is especially important to do this at the beginning of each new season.
- Check swing seats, ropes, cables and chains monthly during usage season for evidence of deterioration. Replacement should be made of any swing seat that has developed cracks in the plastic seats. Ropes, cables and chains should be removed and replaced if excessive wear is found. Contact PlayNation for warranted replacement parts.
- For rusted areas on metallic members such as monkey bars, hand supports brackets, etc.; sand and repaint, using a non lead-based paint meeting the requirements of Title 16 CRF Part 1303.
- Inspect wood parts monthly. The grain of the wood sometimes will lift in the dry season causing splinters to appear. Light sanding may be necessary to maintain a safe playing environment. If you are treating your play set with stain regularly, it will help prevent severe checking/splitting and other weather damage.
- Once or twice a year, depending on your climate conditions, you must apply some type of protection (sealant) to the wood of your unit. Prior to the application of sealant, lightly sand any “rough” spots on your set. Please note this is a requirement of your warranty.
- Creating and maintaining the play set on a level location is very important. As your children play, your play set will slowly dig its way into the soil, and it is very important that it settles evenly. Make sure the play set is level and true once each year or at the beginning of each play season.
- Rake the playground surface periodically to prevent compaction and maintain appropriate depths.
- Disposal Instructions: When the play set is no longer desired, it should be disassembled and disposed of in such away that no unreasonable hazards will exist at the time the unit is discarded.

Play Set Surfacing Recommendations:

Below are some of the recommendations that the U.S. Consumer Product Safety Commission (CPSC) offers from its *Handbook for Public Playground Safety*. The guide can be downloaded in full at www.cpsc.gov/cpsc/pub/pubs/325.pdf

1. Protective Surfacing - Since almost 60% of all injuries are caused by falls to the ground, protective surfacing under and around all playground equipment is the most critical safety factor on playgrounds.

Certain manufactured synthetic surfaces also are acceptable; however, test data on shock absorbing performance should be requested from the manufacturer.

Asphalt and concrete are unacceptable. They do not have any shock absorbing properties. Similarly, grass and turf should not be used. Their ability to absorb shock during a fall can be reduced considerably through wear and environmental conditions.

Certain loose-fill surfacing materials are acceptable such as the types and depths shown in the table.

Fall Heights and Recommended Materials

Type Of Material	6 in. depth	9 in. depth	12 in. depth
Double-Shredded bark mulch	6' Fall Height	10' Fall Height	11' Fall Height
Wood Chips	6' Fall Height	7' Fall Height	12' Fall Height
Fine Sand	5' Fall Height	5' Fall Height	9' Fall Height
Shredded Tires*	10-12' Fall Height	n/a	n/a
Fine Gravel	6' Fall Height	7' Fall Height	10' Fall Height

*This data is from tests conducted by independent testing laboratories on a 6-inch depth of uncompressed shredded tire samples produced by four manufacturers. The tests reported critical heights, which varied from 10 feet to greater than 12 feet. It is recommended that persons seeking to install shredded tires as a protective surface request test data from the supplier showing the critical height of the material when it was tested in accordance with ASTM F1292.

It should be recognized that all injuries due to falls cannot be prevented no matter what surfacing material is used.

2. Fall Zones - A fall zone, covered with a protective surfacing material, is essential under and around equipment where a child might fall. This area should be free of other equipment and obstacles onto which a child might fall. Stationary climbing equipment and slides should have a fall zone extending a Minimum of 6' in all directions from the perimeter of the equipment.

Swings should have a fall zone extending a minimum of 6' from the outer edge of the support structure on each side. The fall zone in front and back of the swing should extend out a minimum distance of twice the height of the swing as measured from the ground to the top of the swing support structure.

Leveling Your Fort During Assembly

- Complete the steps which will be the basic frame of the fort. {i.e. four corner posts with base (sand box boards) and deck supports}
- Position in the most level area chosen for the play set, keeping in mind the location and size of the swing beam, ladder, slides, etc. that extend off the fort.
- Once the frame is in the final position, check for vertical and horizontal levelness to determine which side(s) will need to be dug into the ground to level the play set.
- With a shovel, score the ground around the outside edges of the sandbox boards on the 'high' side of the fort. This is the area that will be dug in. Make sure to score deep enough; the scored lines will be your digging template.
- Push the frame off and away from the scored area, far enough to dig and remove dirt to reach the appropriate depth.
- Dig a channel along the scored line(s) for the base of the fort (corner post and sandbox boards) to rest into. Dig the channel(s) to the same level depth. The bottom of the channel(s) should be level to each other so your frame doesn't teeter or rock because the channel(s) are uneven.
- Once you have removed enough grass and dirt, slide/push the frame into the channel(s). Place a level on the vertical and horizontal boards of the frame to determine if enough soil, or too much, was removed.
- Repeat this process until the basic frame is plumb and level and in its final position before completing the rest of the assembly.
- Measure diagonally make sure fort is square.

Important: if you require a channel depth of more than 6", then we recommend you have your play set area professionally graded before completing assembly.

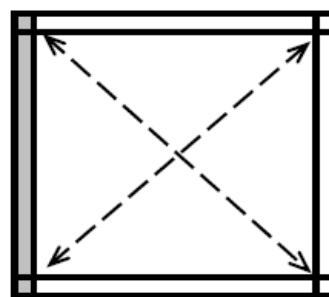
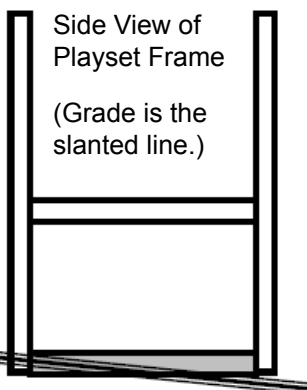

Top View of Playset Frame showing diagonal measurements.

THE DIAGONAL MEASUREMENTS SHOULD BE THE SAME FROM CORNER POST TO CORNER POST. IF NOT, ADJUST FORT SO THAT THE DISTANCE IS EQUAL.

 = AREA TO BE SCORED AND CHANNELLED FOR LEVELNESS

General Info to Review Before Installation

- Depending on your experience, assembly of PlayNation Playsets can take as little as 6 hours up to 24 hours, depending on size, after inventory of parts; therefore, we recommend you set aside a full two days for assembly.
- Identify all of the parts for your play set. Empty each box and lay out boards so you can see each part. Your instruction book will have detailed drawings that will make it easy for you to recognize individual parts. Keep all hardware and metal parts separate from wooden pieces.
- After everything is laid out, check carefully to ensure all parts are present. Make sure there are no broken boards.
- Find an area to sort your hardware. It is best to open the hardware on a solid surface so that you do not lose any pieces in the grass. This will save time and familiarize you with all the different pieces in the hardware bag.
- Important note: Wood has some natural defects such as knots, surface cracks, etc... We reject parts that are structurally defective. We use a high quality lumber in our structures; however, you should inspect each part for splinters or rough spots and sand them smooth to prevent injury.
- After familiarizing yourself with all of the components, read all instructions thoroughly. Reading instructions after you have studied the parts will help you understand more clearly the installation process, and help to eliminate unnecessary mistakes.
- Pay close attention to the diameter and length of each bolt and screw.
- Never tighten hardware completely at first. It helps to have some adjustment for bolt alignment while you are attaching parts together. After everything is square, tighten each joint.
- After the main unit is assembled it is critical that the floor is **level** and **square**. If the main frame is not level, the walls and floor will be out of square.
- After you complete installation, make sure every bolt, screw, and nut is tight, and every board is secure. Wood will expand and contract with the seasons.
- Check all bolt connections and swing hangers seasonally.
- Place the set on level ground, not less than 6ft from any structure or obstruction such as a fence, garage, house, overhanging branches, laundry lines, or electrical wires.

This page is a list of definitions and explanations used throughout our instructions to aid you in the assembly of your play set.

Offset Holes- Throughout the installation procedures we will refer to parts with offset holes. This refers to the orientation of the holes on the board. An offset hole is one that is closer to one side than it is to the other or in other words, it is not centered on the board. In the procedures you will be instructed to attach the boards with the holes “offset up” or with the holes “offset down”. This refers to which side of the board the hole/holes should be closer to. Offset Holes Up= hole/holes will be closer to the top of the board. Offset Holes Down= hole/holes will be closer to the bottom of the board. Note: some parts do not have offset holes, but instead the holes are on center. Therefore there will not be any reference to how to offset these parts.

EXAMPLE OF OFFSET HOLES UP



EXAMPLE OF OFFSET HOLES DOWN



Counterbored holes- Many of the parts that will be used have counterbored holes. A counterbored hole is one that surrounds one side of a thru hole, but does not extend through the wood itself. When using a counterbored hole the bolt will be inserted through the thru hole. In some cases the bolt head with a washer will occupy the counterbored hole. In other cases a nut with a washer will occupy the counterbored hole.

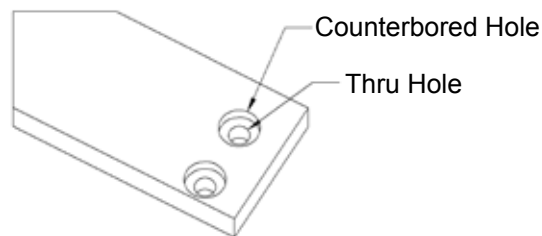

Lag Screws- Lag screws are used in the construction of our play sets to enhance the structural integrity of the unit. There will not be predrilled holes in the post for lag screw installation. Lag screws are self-tapping, though if you are using a manual socket wrench it may be necessary to tap the head of the lag screw with a hammer. You should also be sure to tighten the lag screws completely. Power tools such as an impact wrench or power drill should have enough torque to drive the lag screws without using a hammer, but make sure not to over tighten as this can cause the threads to “strip out” in the post.

Please familiarize yourself with the manual, parts/components and general construction process of your new playset before getting started.

SITE PLAN:

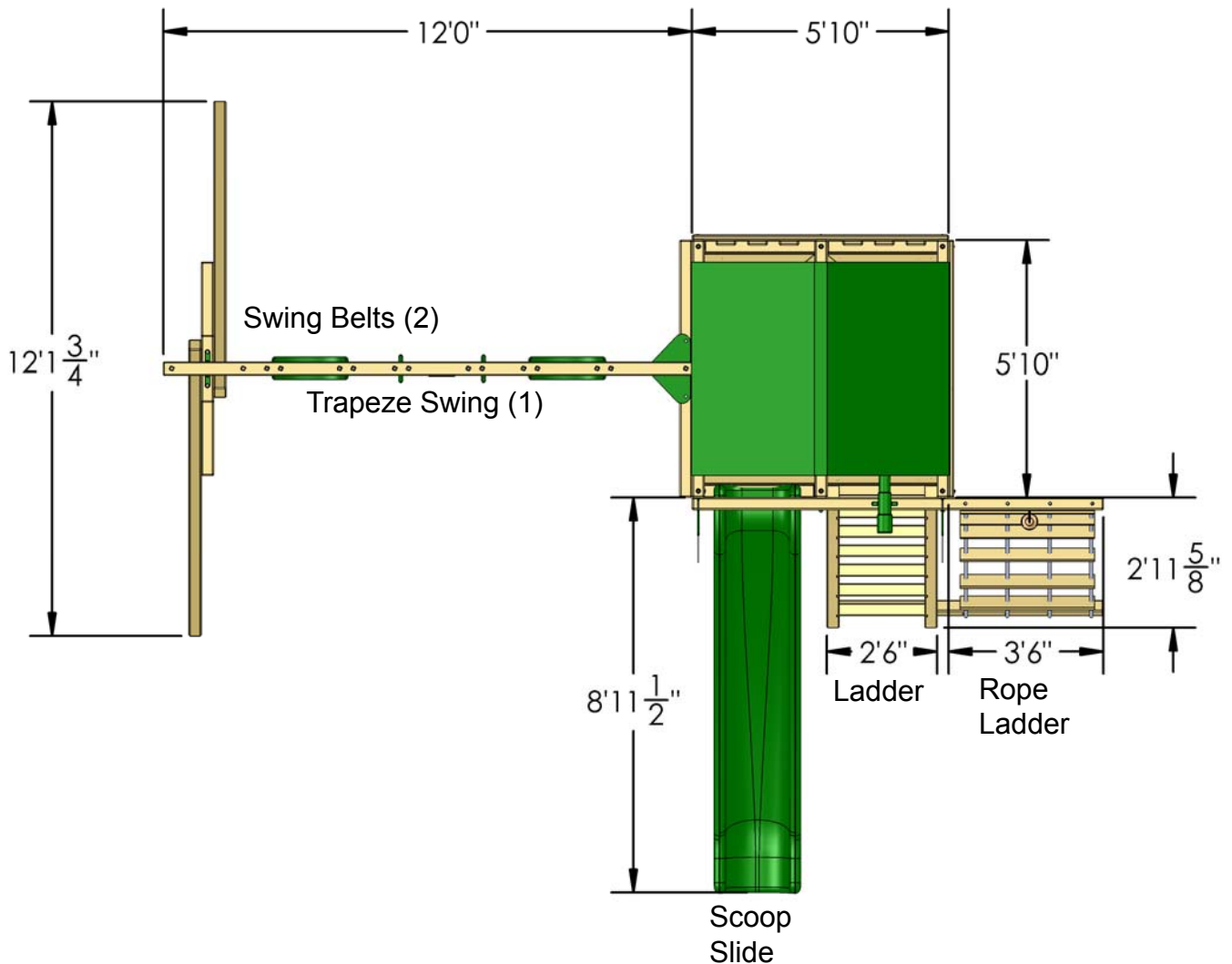

Playset height: 12 feet - 6 inches

Deck height: 6 feet - 1/2 inch

Swing Beam height to top: 8 feet - 11 inches

Approximate assembly time: 8 to 10 hours

6 foot unobstructed safety perimeter around playset recommended

REQUIRED TOOL LIST:

- ___ Standard or Cordless Drill w/ Phillips Bit (#2 square bit provided)
- ___ 1/8" Drill Bit
- ___ 3/8" Drill Bit
- ___ 1/2" Wrench and Socket
- ___ 1/2" Deep Well Socket
- ___ 9/16" Deep Well Socket
- ___ 9/16" Wrench and Socket
- ___ Level
- ___ Tape Measure
- ___ Extension Cord (if using standard drill)
- ___ Hammer
- ___ Pencil
- ___ Locking Pliers (Vise Grips)
- ___ Shovel

KIT CONTENTS:

Swings, Slides, Accessories:

- ___ (Qty) Description
- ___ (2) Swingbelts w/ Chains
- ___ (1) Super Scoop Slide
- ___ (1) Assembly Manual
- ___ (1) Deluxe Rope Ladder
- ___ (1) Trapeze Swing
- ___ (1) Telescope
- ___ (1) Steering Wheel
- ___ (2) Safety Handles - metal
- ___ (1) Dinner Bell
- ___ (1) Flag Kit (pair)
- ___ (1) Tarp (canopy)

Fort and Swing Beam Hardware:

see following pages

Wood Components:

see following pages

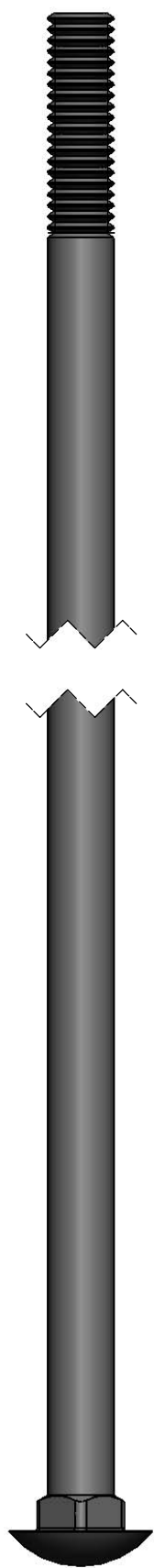

3/8 X 12"
CARRIAGE BOLT
QTY: 1

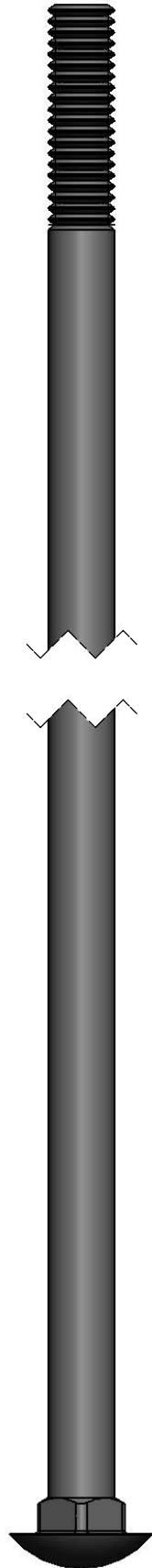

3/8 X 11"
CARRIAGE BOLT
QTY: 1

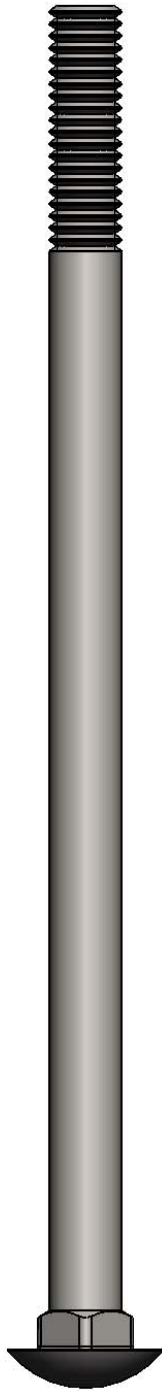

3/8 X 7"
CARRIAGE BOLT
QTY: 2

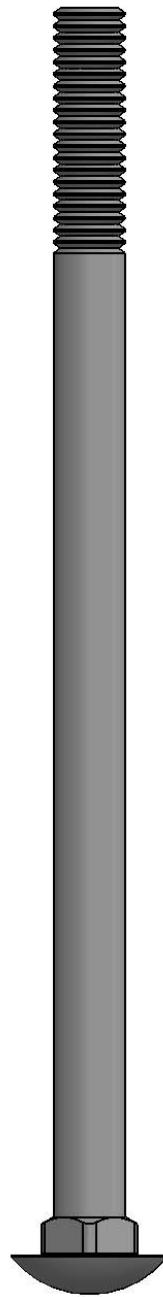

3/8 X 6-1/2"
CARRIAGE BOLT
QTY: 28

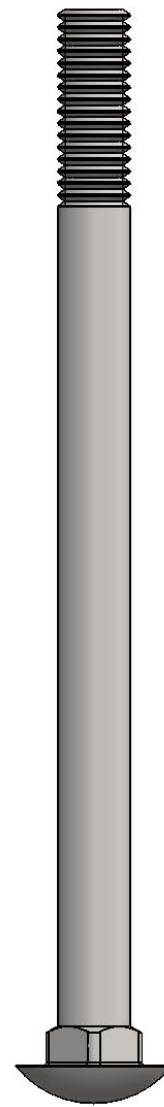

3/8 x 5-1/2"
CARRIAGE BOLT
QTY: 2

9
8
7
6
5
4
3
2
1

USE THE RULER TO THE RIGHT TO MEASURE YOUR BOLTS AND SCREWS. PICTURE VIEWS SHOWN ABOVE ARE 1:1 SCALE AND CAN BE USED TO MATCH BOLT AND SCREW SIZES. 15

#14 X 1 1/4"
PAN HEAD
SCREW
QTY: 7

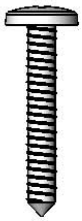

#8 X 1 1/2"
WOOD SCREW
QTY: 8



#8 X 2"
WOOD SCREW
QTY: 160

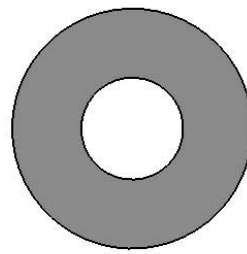

1/2 WASHER
QTY: 3

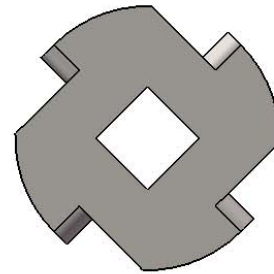

TORQUE WASHER
QTY: 29

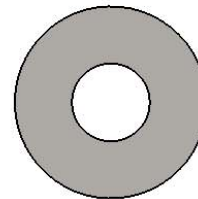

3/8 WASHER
QTY: 138

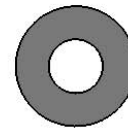

1/4 WASHER
QTY: 4

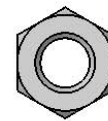

3/8 LOCK NUT
QTY: 34



PLASTIC
BOLT CAP
QTY: 34

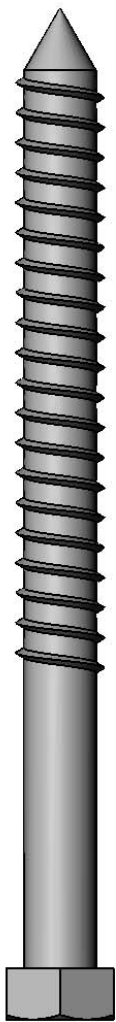

3/8 x 5"
HEX LAG SCREW
QTY: 21

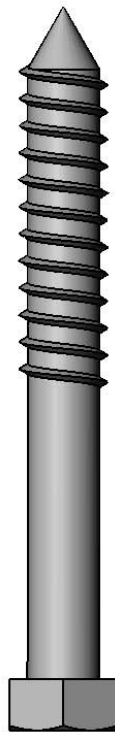

3/8 x 3-1/2"
HEX LAG SCREW
QTY: 83

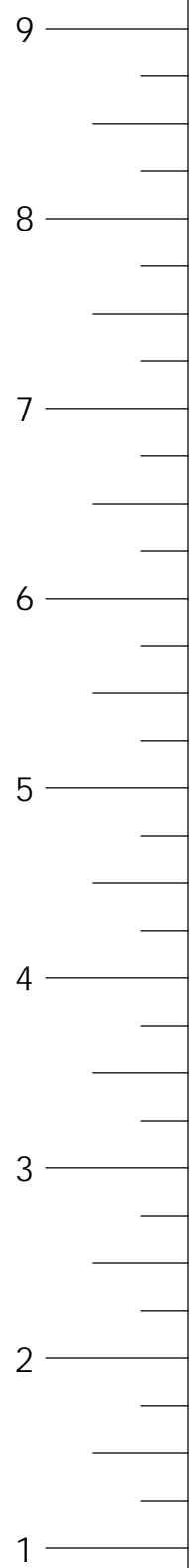

USE THE RULER TO THE RIGHT TO MEASURE YOUR BOLTS AND SCREWS. PICTURE VIEWS SHOWN ABOVE ARE 1:1 SCALE AND CAN BE USED TO MATCH BOLT AND SCREW SIZES. 16



PICTURE	DESCRIPTION	QTY.
	5/4 X 3 1/2 X 29 3/4" DECK SPACER	4
	5/4 X 3 1/2 X 62 3/4" DECK SPACER	2
	2 X 4 X 70" CENTER DECK SUPPORT	2
	2 X 4 X 70" TARP BOARD	3
	2 X 4 X 70" SAFETY BOARD	1
	2 X 4 X 70" DECK SUPPORT	2
	2 X 6 X 70" FILLER BOARD	3

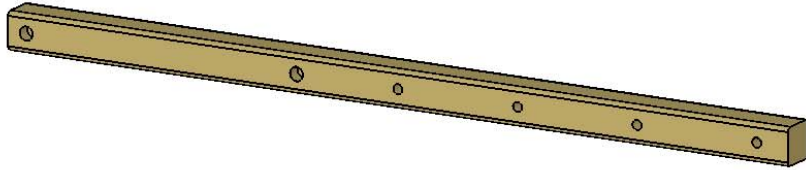
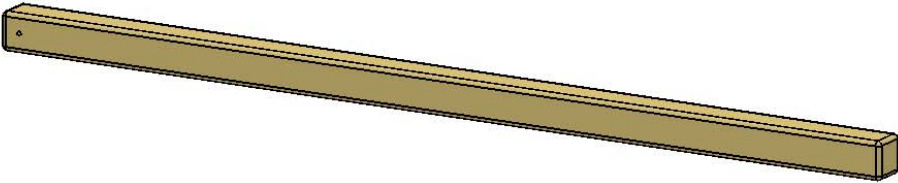
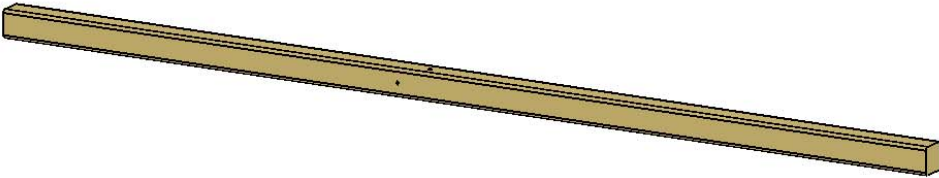
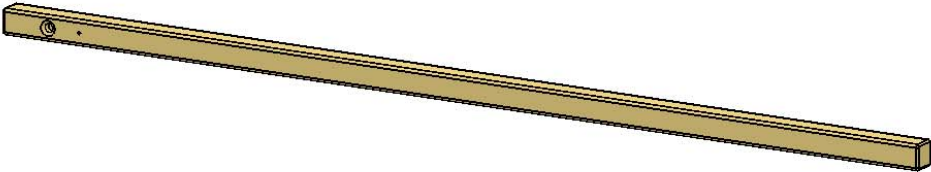
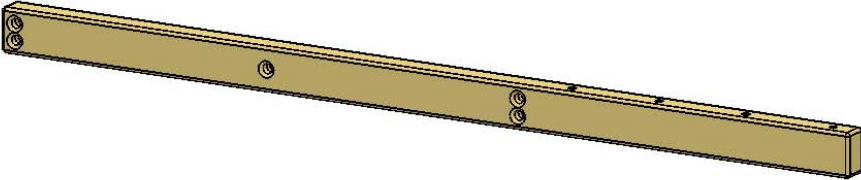
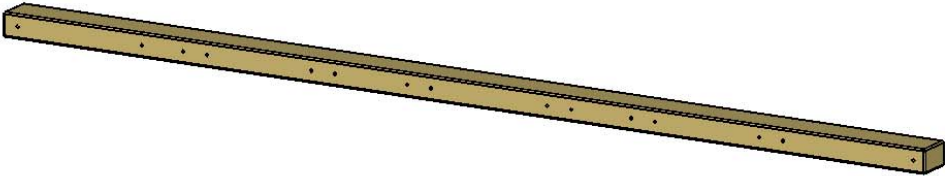
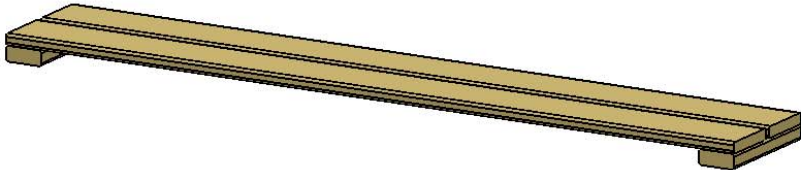

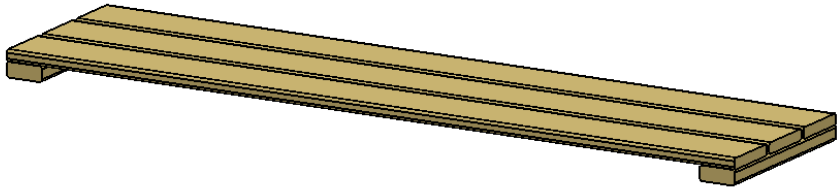
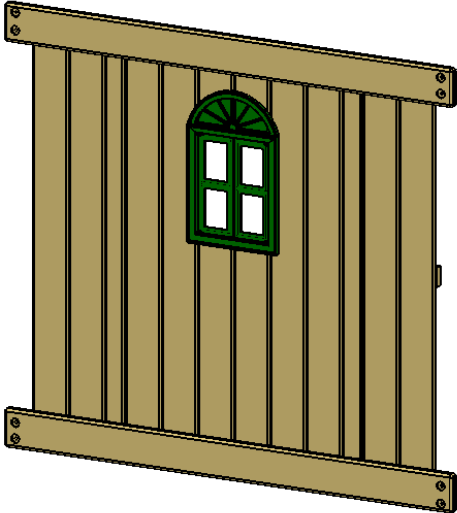
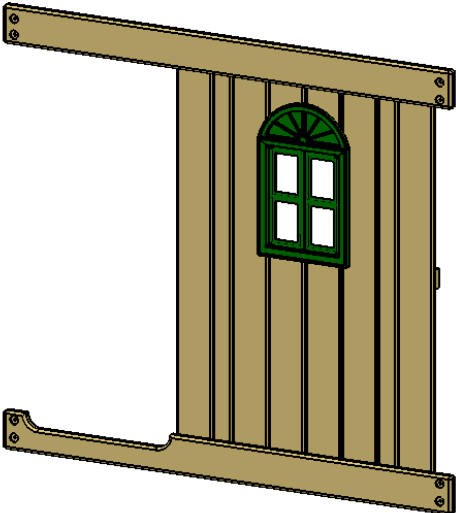
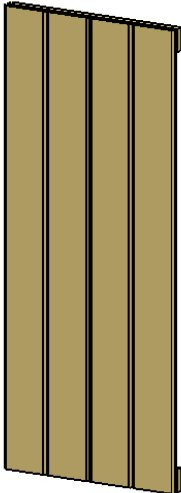
PICTURE	DESCRIPTION	QTY.
	4 X 4 X 18" SWING BLOCK	1
	4 X 4 X 18" SWING BLOCK WITH ANGLE	1
	4 X 4 X 25" BLOCK	4
	4 X 4 X 58" CROSS MEMBER	1
	4 X 4 X 62 3/4" LOWER/UPPER DECK SUPPORTS	2
	4 X 4 X 70" BLOCK SUPPORTS	2
	4 X 4 X 70" DECK SUPPORTS	2

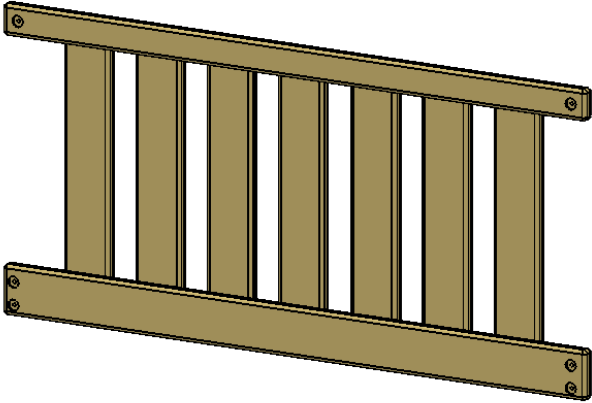
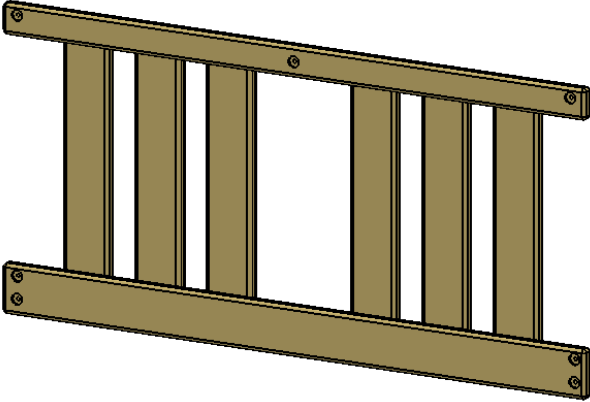
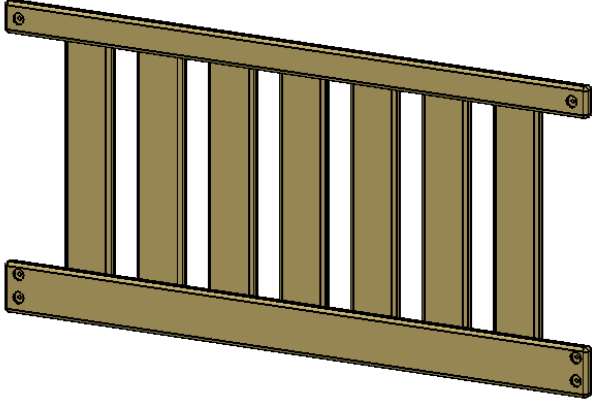
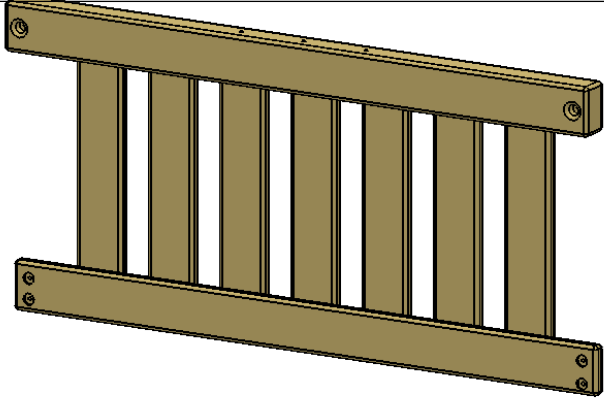

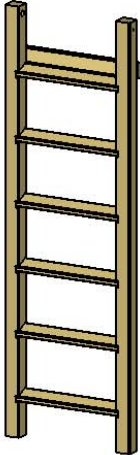
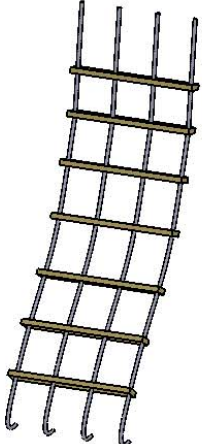

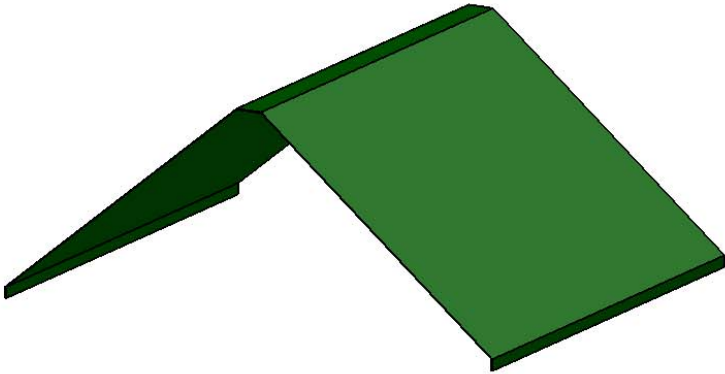

PICTURE	DESCRIPTION	QTY.
	4 X 4 X 75" ROPE LADDER RUNNER	1
	4 X 4 X 84" CENTER POST	2
	4 X 4 X 122" CORNER POST	4
	4 X 4 X 132" SWING BEAM LEGS	2
	4 X 6 X 112" ROPE LADDER SUPPORT	1
	4 X 6 X 144" SWING BEAM	1
	PRE ASSEMBLED 11 1/4 X 69 1/2" 2-BOARD DECK	2

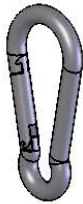
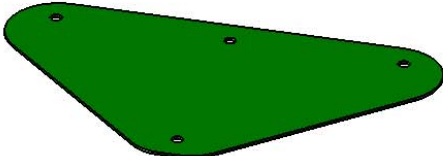
PICTURE	DESCRIPTION	QTY.
	<p>PRE ASSEMBLED 16 7/8 X 69 1/2" 3-BOARD DECK</p>	<p>6</p>
	<p>PRE ASSEMBLED SIDE WALL PANEL</p>	<p>2</p>
	<p>PRE ASSEMBLED DOOR WALL PANEL</p>	<p>1</p>
	<p>PRE ASSEMBLED DOOR</p>	<p>1</p> <p>20</p>

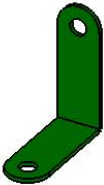
PICTURE	DESCRIPTION	QTY.
	<p>PRE-ASSEMBLED SIDE PANEL (4 HOLES OFFSET DOWN)</p>	<p>1</p>
	<p>PRE-ASSEMBLED SIDE PANEL WITH 7 HOLES (5 HOLES OFFSET UP)</p>	<p>1</p>
	<p>PRE-ASSEMBLED RAILING (4 HOLES OFFSET UP)</p>	<p>1</p>
	<p>PRE-ASSEMBLED SIDE PANEL WITH SWING BEAM SUPPORT</p>	<p>1</p>

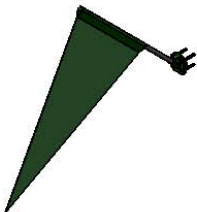
PICTURE	DESCRIPTION	QTY.
	<p>PRE ASSEMBLED 5 STEP LADDER</p>	<p>1</p>
	<p>ROPE LADDER ASSEMBLY</p>	<p>1</p>
	<p>12' SCOOP SLIDE</p>	<p>1</p>
	<p>SWING WITH CHAINS</p>	<p>2</p>

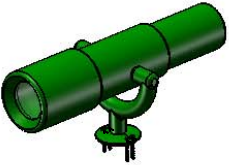
PICTURE	DESCRIPTION	QTY.
	TRAPEZE BAR WITH CHAINS	1
	TARP	1
	IRON DUCTILE SWING HANGER	6
	SPRING CLIP	6
	SWING PLATE	1

PICTURE	DESCRIPTION	QTY.
	90 GREEN BRACKET	2
	45 GREEN BRACKET	2
	METAL SAFETY HANDLES	2
	PLASTIC FLAG KIT	2
	DINNER BELL	1
	STEERING WHEEL	1
	TELESCOPE	1
	NAME PLATE	1

STEP 1: CORNER POSTS

1. PLACE TWO 4 X 4 X 122" CORNER POSTS FLAT ON THE GROUND WITH THE 69 7/8" PILOT HOLES FACING UP. PLACE A 2 X 4 X 70" DECK SUPPORT FLUSH TO THE BOTTOM AND SIDES OF THE TWO CORNER POST, WITH COUNTERSUNK HOLES FACING UP AND OFFSET UP. FASTEN THE SANDBOX BOARD TO THE CORNER POST WITH 3/8 X 3 1/2" LAG SCREWS AND 3/8" WASHERS.
2. PLACE THE 4 X 4 X 70" DECK SUPPORT FLUSH WITH THE TWO CORNER POST AT THE 69 7/8" PILOT HOLES. FASTEN THE DECK SUPPORT TO THE CORNER POST FROM THE OUTSIDE WITH 3/8" X 6 1/2" CARRIAGE BOLT AND TORQUE WASHER THEN A 3/8" WASHER AND 3/8" LOCKNUT FROM THE INSIDE. USE BOLT CAPS TO COVER ALL EXPOSED THREADS.
3. REPEAT STEPS 1 AND 2 TO COMPLETE SECOND SIDE.

NOTE: BE SURE THAT SANDBOX BOARDS AND DECK SUPPORT BOARDS ARE ON THE INSIDE BEFORE PROCEEDING TO THE NEXT STEP, AS SHOWN BELOW.

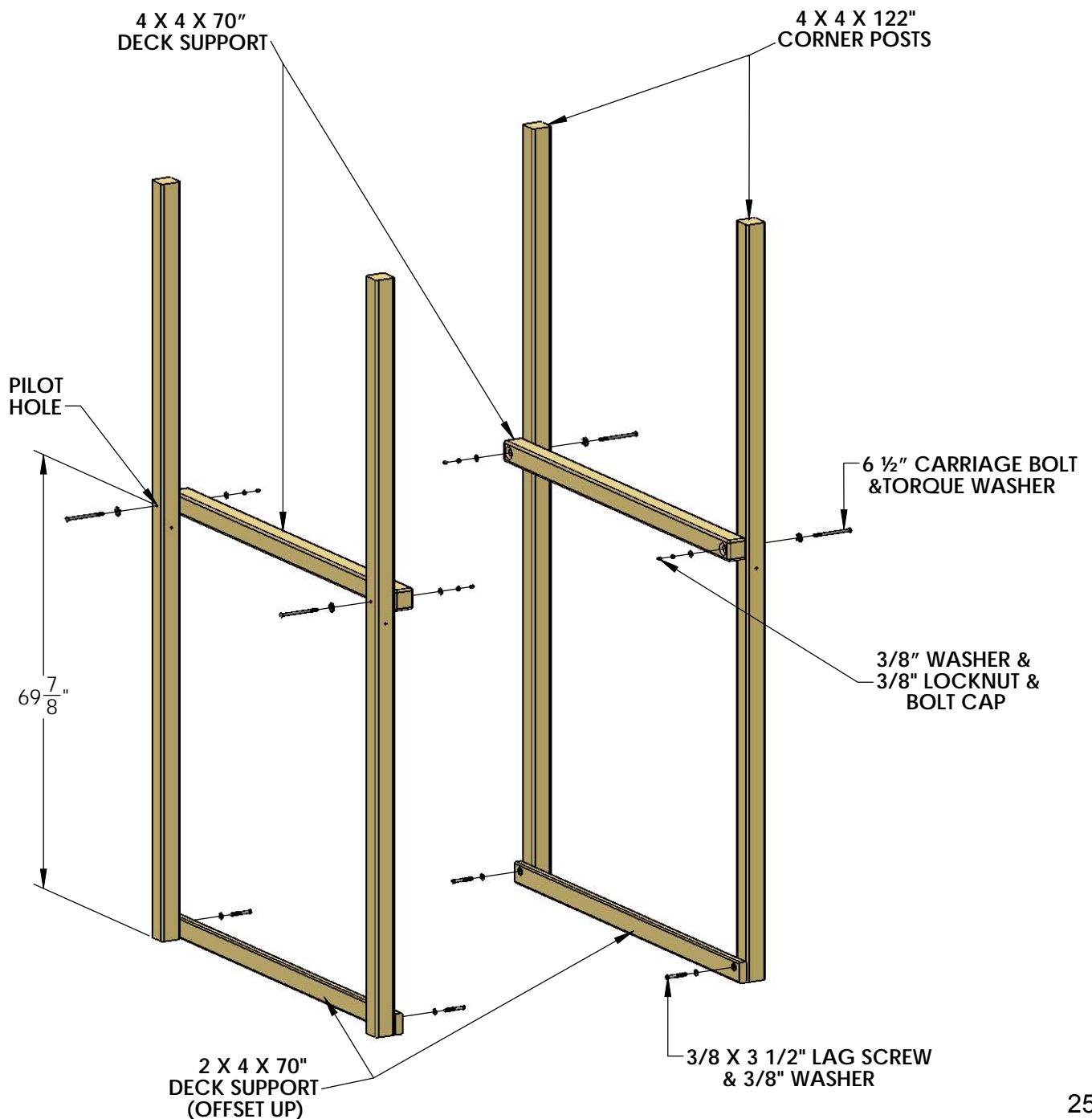

STEP 2: BLOCK SUPPORTS

1. PLACE THE TWO 4 X 4 X 70" BLOCK SUPPORTS FLUSH WITH THE CORNER POSTS AT THE 66 1/2" PILOT HOLES (THE 2 COUNTERSUNK HOLES ON THE BLOCK SUPPORTS FACE DOWN, THE 3 COUNTERSUNK HOLES FACE IN), AS SHOWN BELOW. FASTEN THE BLOCK SUPPORTS FROM THE OUTSIDE TO THE CORNER POST WITH A 3/8" X 6 1/2" CARRIAGE BOLT AND TORQUE WASHER THEN A 3/8" WASHER AND 3/8" LOCKNUT FROM THE INSIDE. USE BOLT CAPS TO COVER ALL EXPOSED THREADS. FASTEN THE BLOCK SUPPORTS FROM THE BOTTOM UP INTO THE DECK SUPPORTS WITH A 3/8" X 5" LAG SCREW AND 3/8" WASHER.

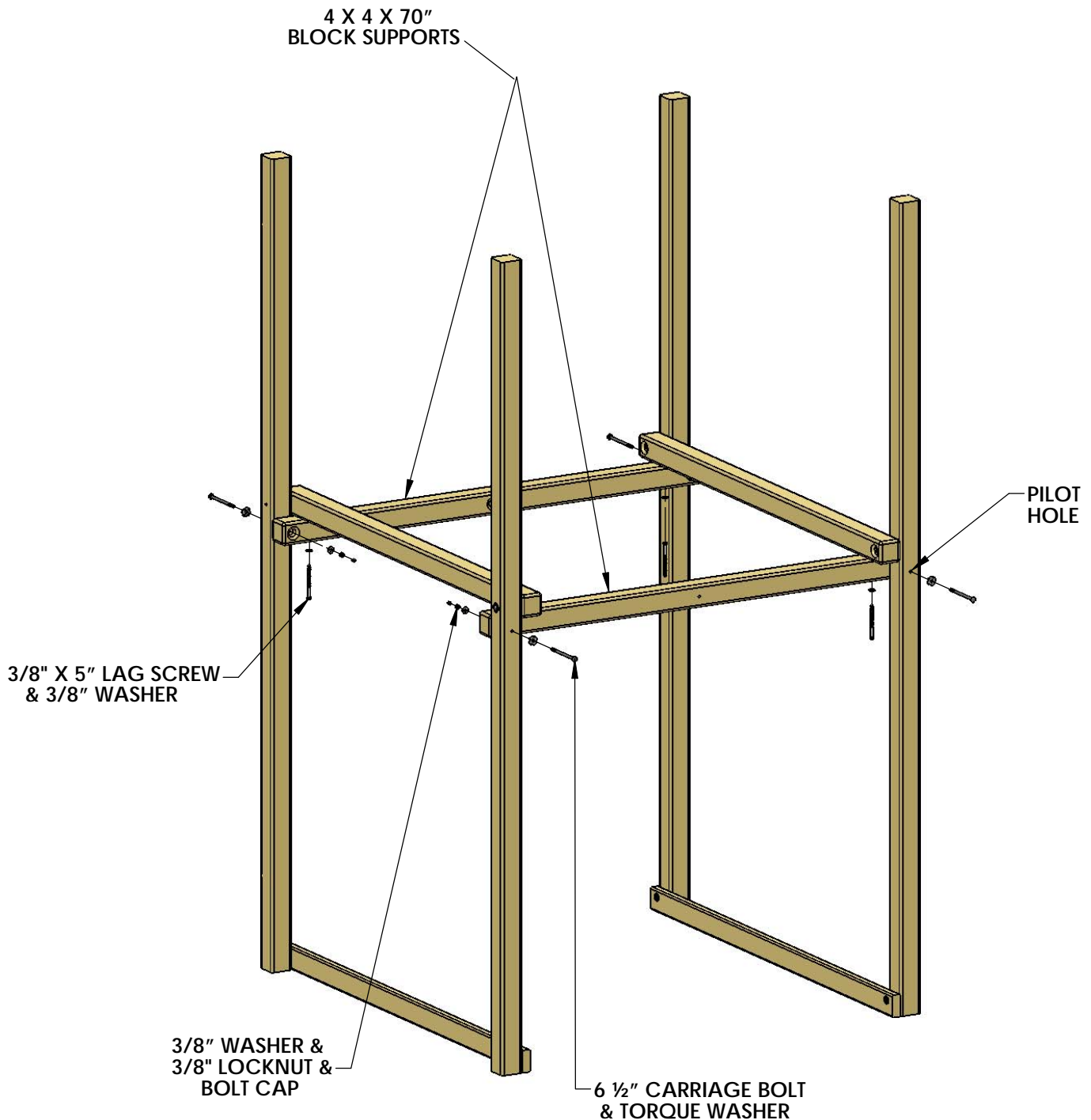

STEP 3: LOWER DECK BOARDS

1. PLACE THE 4 X 4 X 62-3/4" LOWER DECK SUPPORT FLUSH WITH THE ENDS OF THE SANDBOX BOARDS AND CENTERED, AS SHOWN BELOW. THE LOWER DECK SUPPORT DOES NOT REQUIRE SCREWS AT THIS TIME.
2. PLACE PRE-ASSEMBLED DECK BOARD SECTIONS ON TOP OF DECK SUPPORTS, AS SHOWN BELOW. BE SURE THEY ARE EVENLY SPACED. SECURE EACH DECK BOARD WITH TWO 2" WOOD SCREWS AT EACH DECK SUPPORT, FOR A TOTAL OF SIX SCREWS PER BOARD.

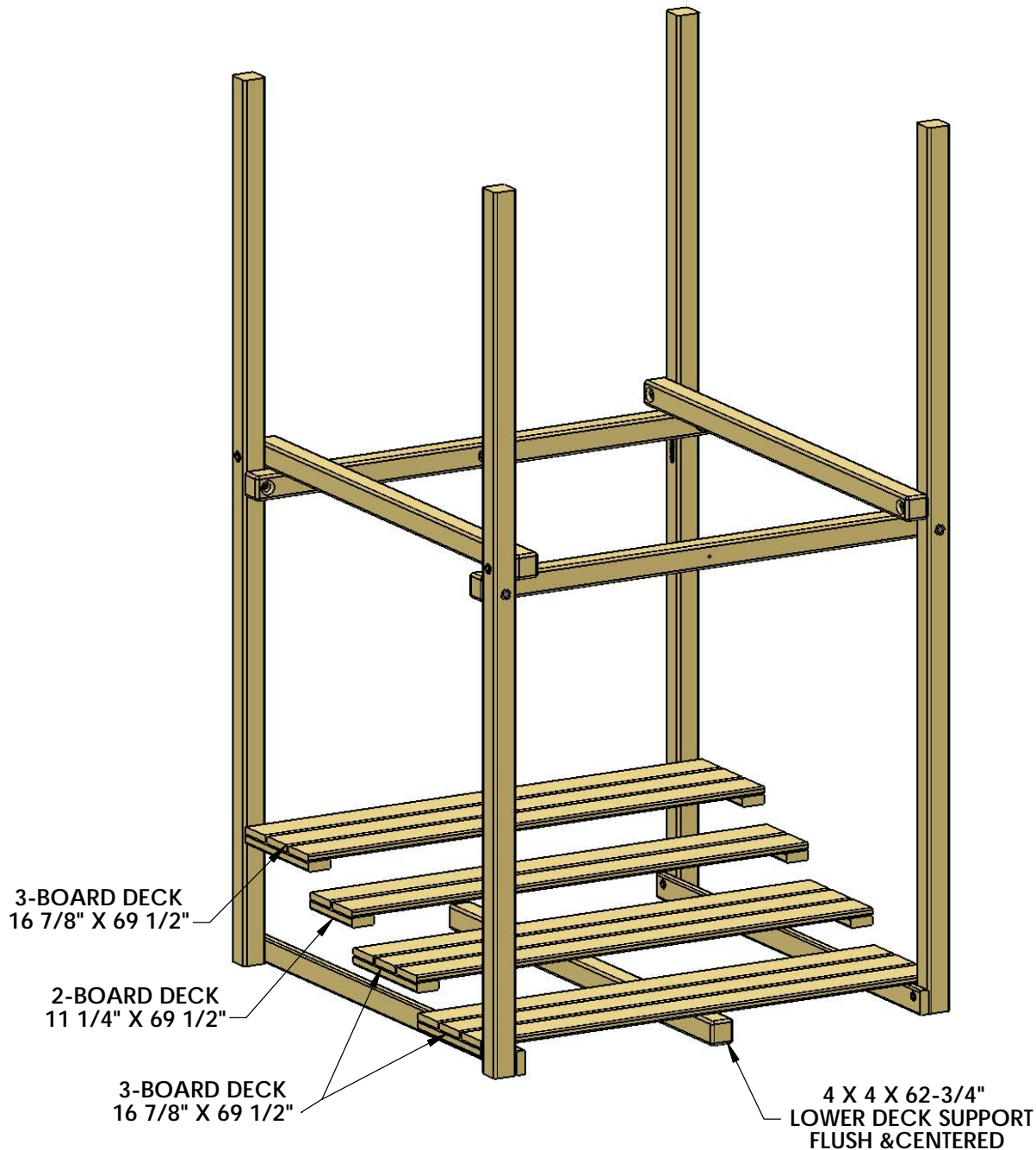

STEP 4: COMPLETION OF LOWER DECK

1. PLACE THE TWO 5/4 X 3 1/2 X 62 3/4" DECK SPACER BOARDS ACROSS THE TOP OF THE DECK SUPPORTS AND BETWEEN THE CORNER POSTS, AS SHOWN BELOW.
2. MAKE SURE THE DECK SPACERS ARE EVENLY SPACED AND CENTERED. SECURE EACH BOARD WITH TWO 2" WOOD SCREWS TO DECK SUPPORTS, FOR A TOTAL OF SIX SCREWS PER BOARD.

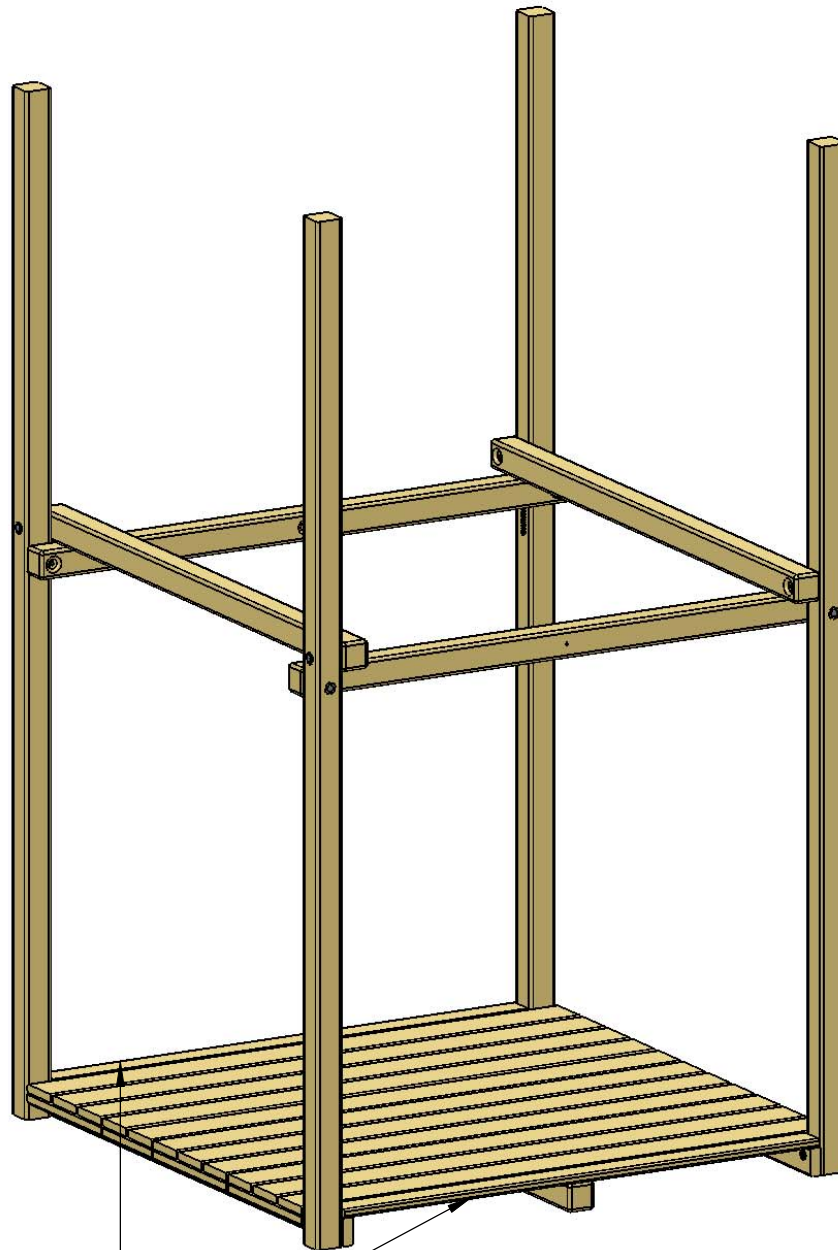

5/4 X 3 1/2 X 62 3/4"
DECK SPACER BOARD

STEP 5: CENTER POSTS

1. PLACE THE 4 X 4 X 84" CENTER POSTS FLUSH WITH THE BOTTOM OF THE BLOCK SUPPORTS, LINING UP THE PILOT HOLES AT THE CENTER OF THE BLOCK SUPPORTS. FASTEN FROM THE OUTSIDE WITH A 3/8" X 6 1/2" CARRIAGE BOLT AND TORQUE WASHER THEN A 3/8" WASHER AND 3/8" LOCKNUT ON THE INSIDE. USE BOLT CAPS TO COVER ALL EXPOSED THREADS.

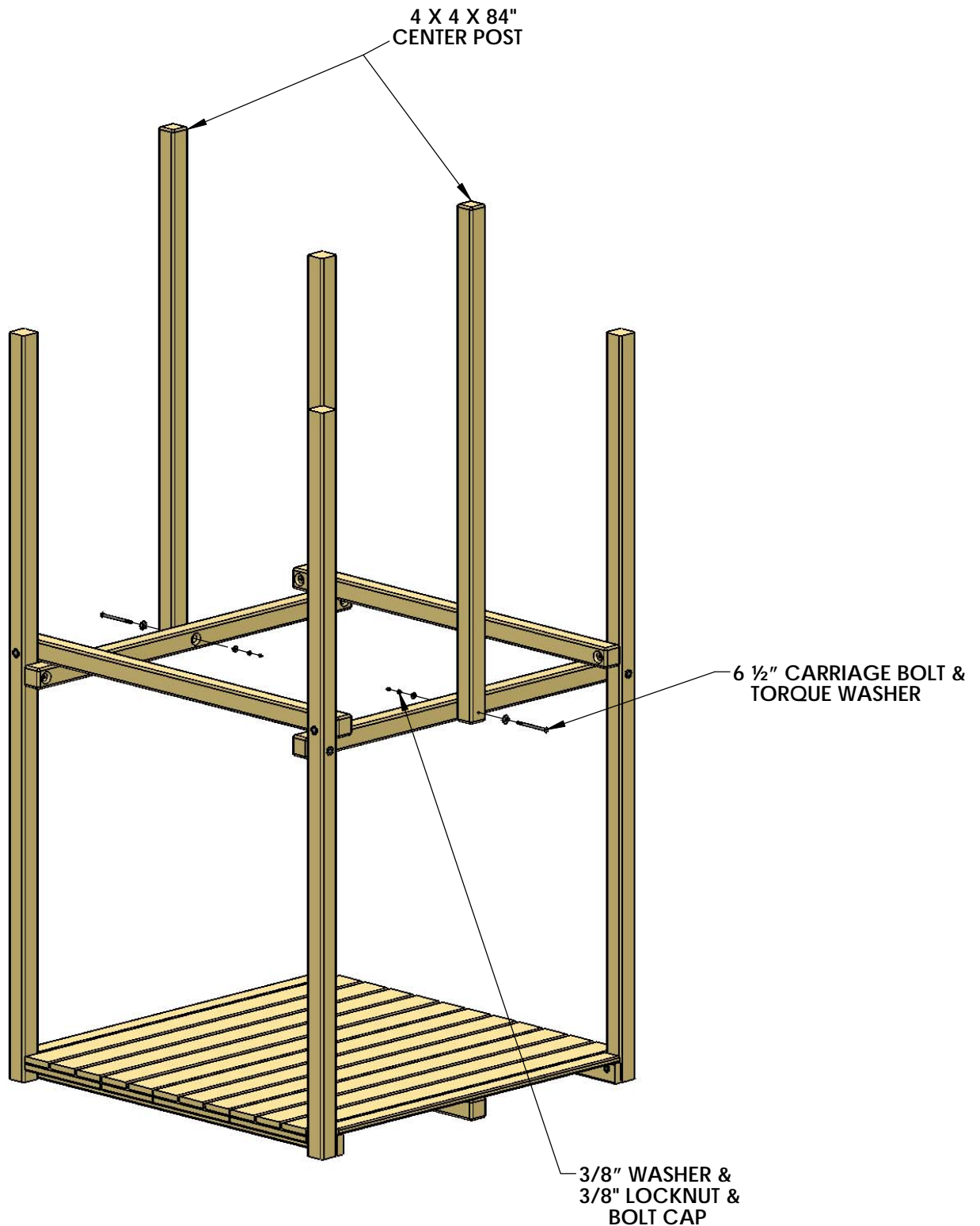

STEP 6: CENTER DECK SUPPORTS

1. PLACE THE 4 X 4 X 62 3/4" UPPER DECK SUPPORT FLUSH ON TOP OF THE BLOCK SUPPORTS, IN LINE WITH THE CENTER POST. THE UPPER DECK SUPPORT DOES NOT REQUIRE SCREWS AT THIS TIME.
2. PLACE THE 2 X 4 X 70" CENTER DECK SUPPORTS FLUSH AGAINST THE CENTER POSTS AND UPPER DECK SUPPORT AND ON TOP OF THE BLOCK SUPPORTS. MAKE SURE THE COUNTERSUNK HOLES ON CENTER DECK SUPPORTS ARE OFFSET UP ON ONE SIDE AND ARE OFFSET DOWN ON THE OTHER SIDE. FASTEN THE CENTER DECK SUPPORTS TO THE CENTER POST AND UPPER DECK SUPPORT WITH 3/8 X 3 1/2" LAG SCREWS AND 3/8" WASHERS.

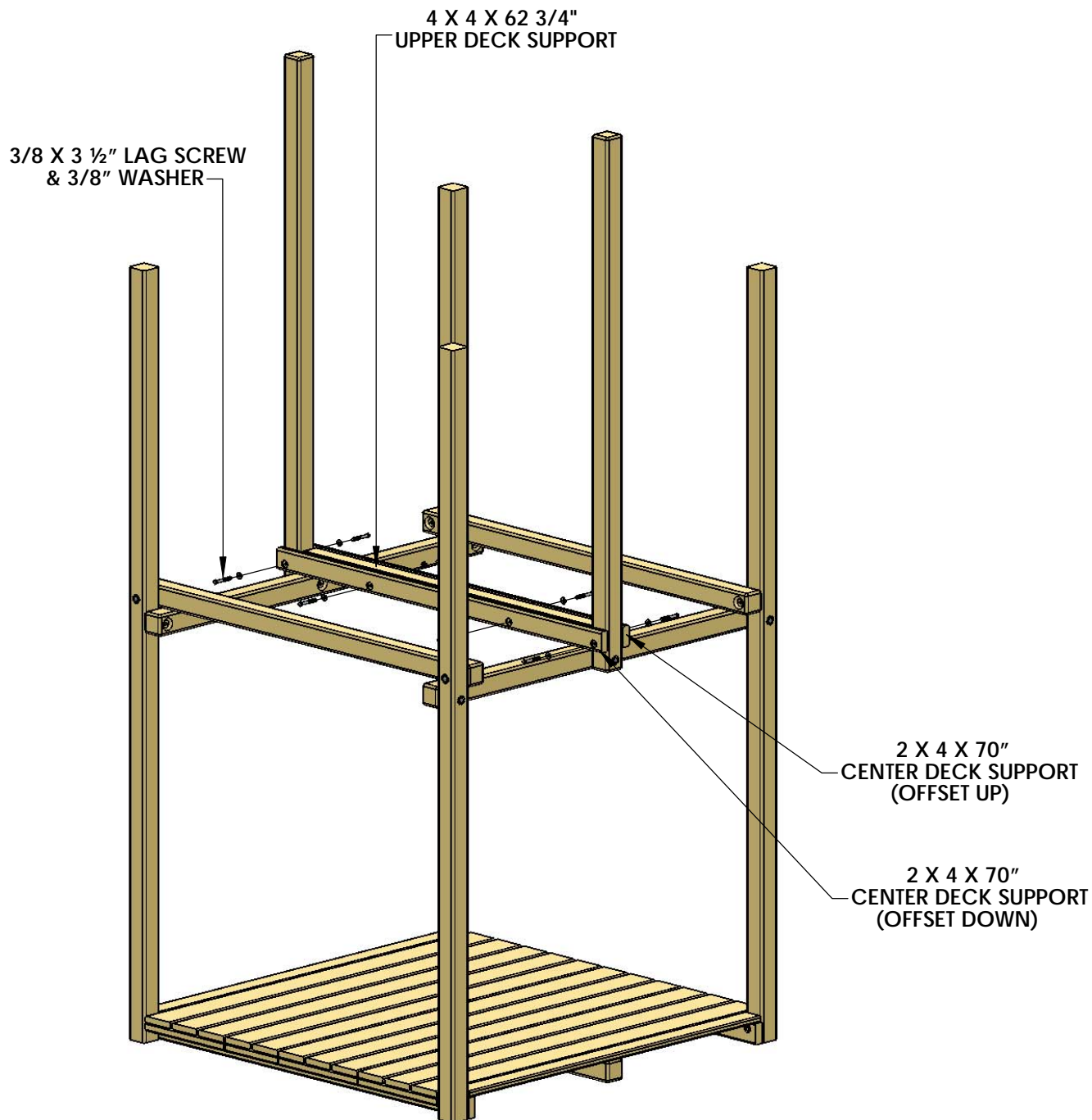

STEP 7: BLOCKS

1. PLACE THE 4 X 4 X 25" BLOCKS (COUNTERSUNK HOLES FACE UP) ON TOP OF THE BLOCK SUPPORTS BETWEEN THE DECK SUPPORTS AND CENTER DECK SUPPORTS. FASTEN THE BLOCKS TO THE BLOCK SUPPORTS WITH 3/8" X 5" LAG SCREWS AND 3/8" WASHERS.

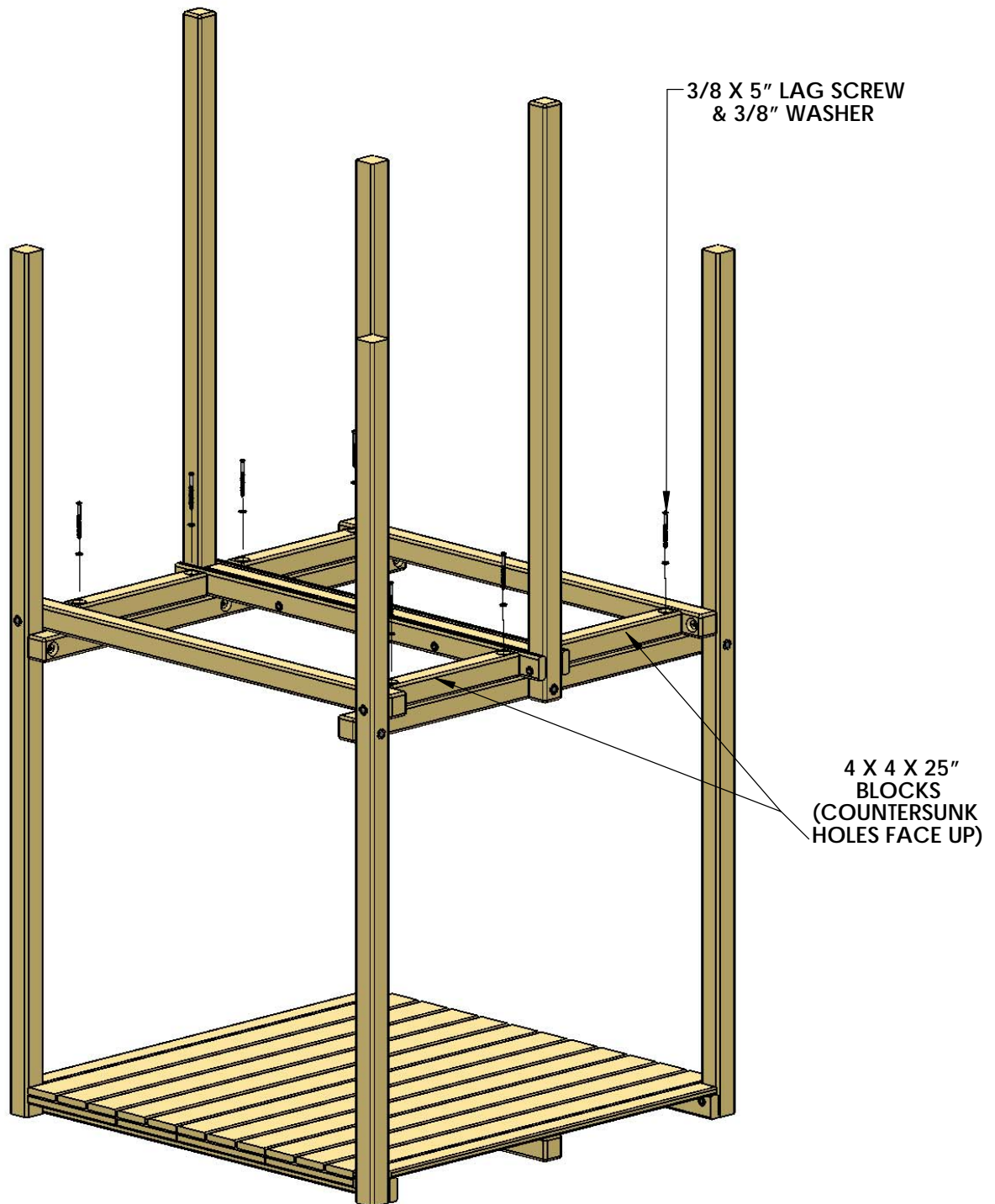

STEP 8: UPPER DECK BOARDS

1. PLACE PRE-ASSEMBLED DECK BOARD SECTIONS ON TOP OF DECK SUPPORTS AND CENTER DECK SUPPORTS, AS SHOWN BELOW. BE SURE THEY ARE EVENLY SPACED. SECURE EACH DECK BOARD WITH TWO 2" WOOD SCREWS AT EACH DECK SUPPORT, FOR A TOTAL OF SIX SCREWS PER BOARD.

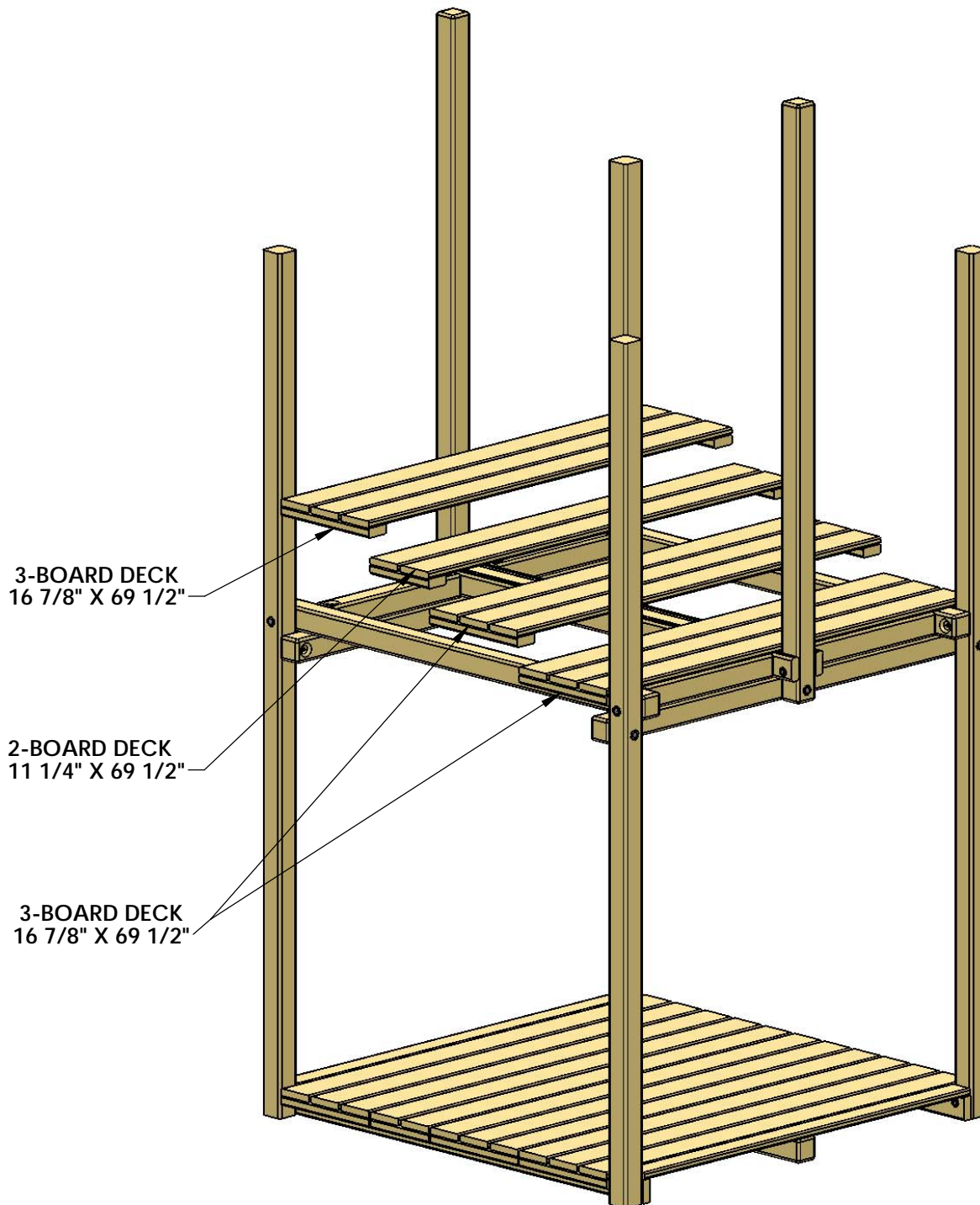

STEP 9: COMPLETION OF UPPER DECK

1. PLACE THE 5/4 X 3-1/2 X 29-3/4" DECK SPACER BOARDS ON TOP OF THE DECK SUPPORTS BETWEEN THE CORNER AND CENTER POSTS, AS SHOWN BELOW. MAKE SURE THE DECK SPACERS ARE EVENLY SPACED AND CENTERED. SECURE EACH DECK SPACER WITH TWO 2" WOOD SCREWS TO DECK AND CENTER DECK SUPPORTS ON EACH END.

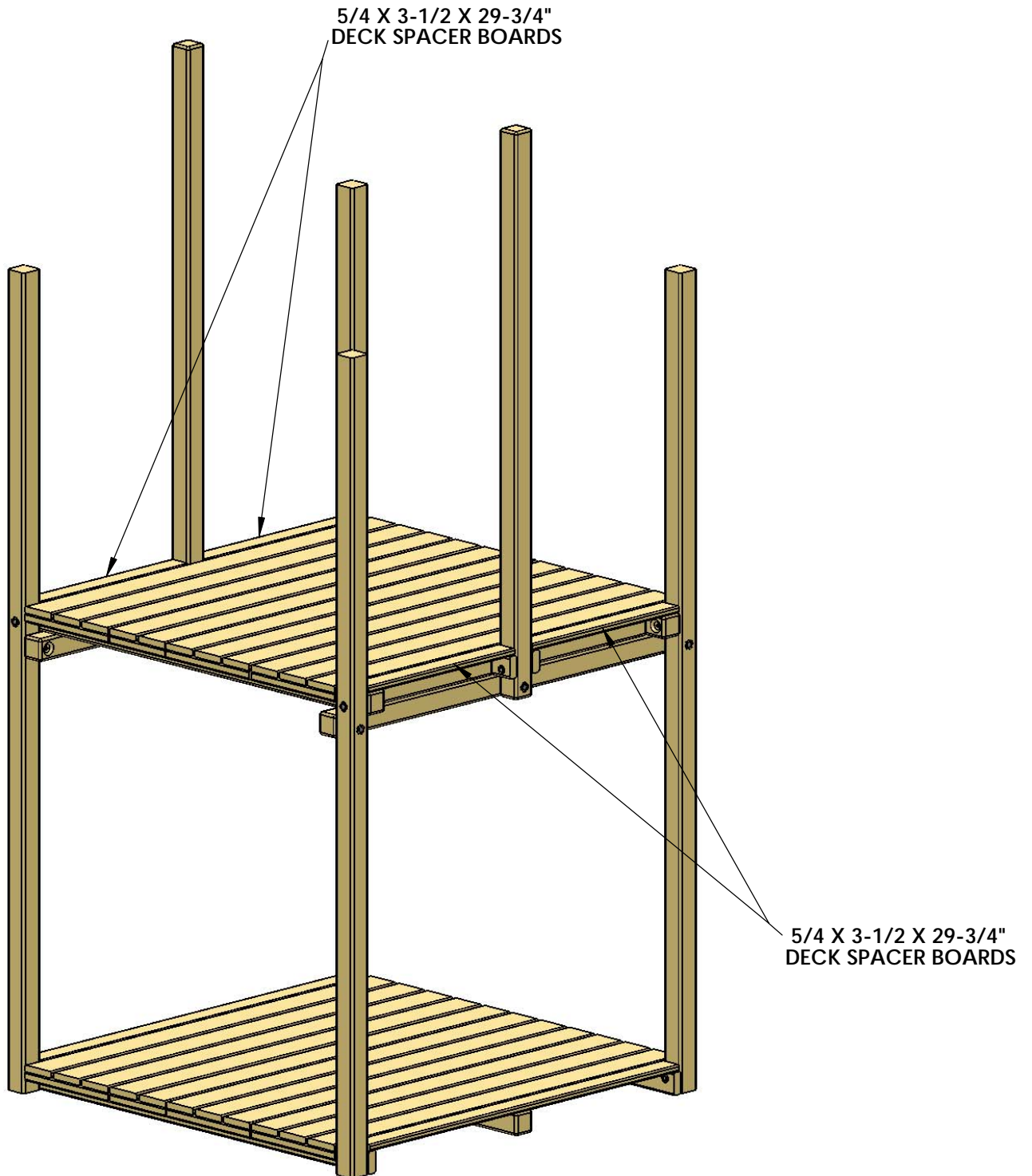

STEP10: SIDE WALL PANELS

1. PLACE PRE-ASSEMBLED SIDE WALL PANEL FLUSH WITH CORNER POSTS, ALLOWING PANELS BOARDS TO REST ON DECK ON THE INSIDE. BE SURE THAT COUNTERSUNK HOLES OFFSET UP ON TOP BOARD AND OFFSET DOWN ON BOTTOM BOARD OF WALL ASSEMBLY. FASTEN SIDE WALL PANEL INTO CORNER POSTS WITH 3/8" X 3 1/2" LAG SCREWS AND 3/8" WASHERS.
2. PLACE THE 2 X 6 X 70" FILLER BOARD (COUNTERSUNK HOLES OFFSET DOWN) FLUSH WITH THE CORNER POST AND WALL ASSEMBLY. FASTEN INTO CORNER POSTS WITH 3/8" X 3 1/2" LAG SCREWS AND 3/8" WASHERS.
3. REPEAT STEPS 1 AND 2 FOR THE OTHER SIDE.

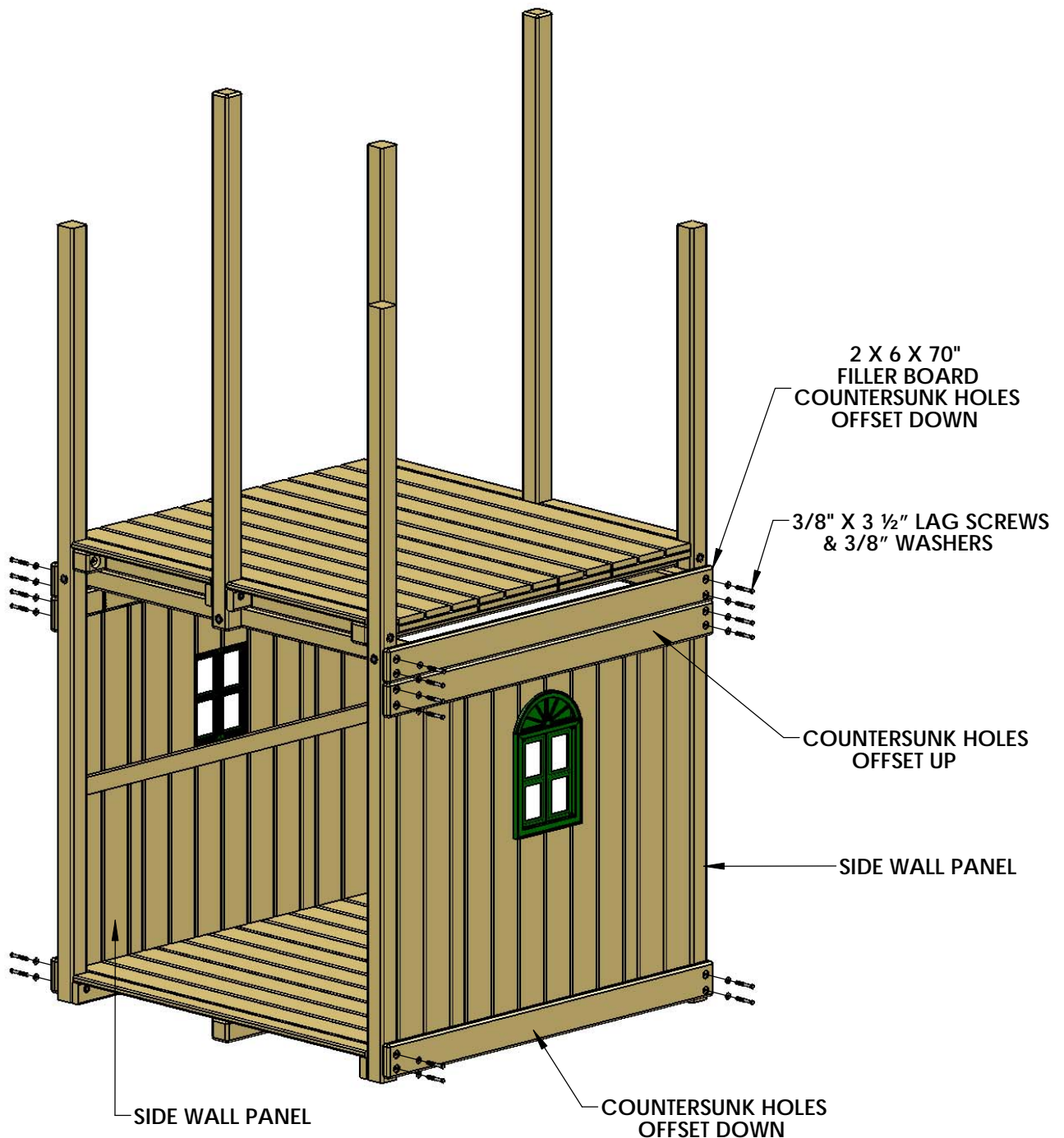

STEP 12: DOOR WALL PANEL

1. PLACE PRE-ASSEMBLED DOOR PANEL FLUSH WITH CORNER POSTS, ALLOWING PANEL BOARDS TO REST ON DECK ON THE INSIDE. BE SURE THAT COUNTERSUNK HOLES OFFSET DOWN ON TOP BOARD AND OFFSET UP ON BOTTOM BOARD OF DOOR PANEL ASSEMBLY. FASTEN TO CORNER POST WITH 3/8" X 3 1/2" LAG SCREWS AND 3/8" WASHERS.
2. PLACE THE 2 X 6 X 70" FILLER BOARD (COUNTERSUNK HOLES OFFSET UP) FLUSH WITH THE CORNER POST AND WALL ASSEMBLY. FASTEN TO CORNER POST WITH 3/8" X 3 1/2" LAG SCREWS AND 3/8" WASHERS.
3. PLACE DOOR INSIDE OF FORT. FLUSH SIDE OF DOOR WITH CORNER POST AND TOP OF DOOR WITH THE DOOR PANEL ASSEMBLY. PLACE A 1/2" WOOD PIECE UNDER DOOR FOR STABILITY. FASTEN HINGES TO THE INSIDE OF FRONT CORNER POST WITH 1 1/2" WOOD SCREWS. DOOR WILL OPERATE WITH AN IN-SWING OPENING.

NOTE: DECK AND WALL OMITTED FOR CLARITY.

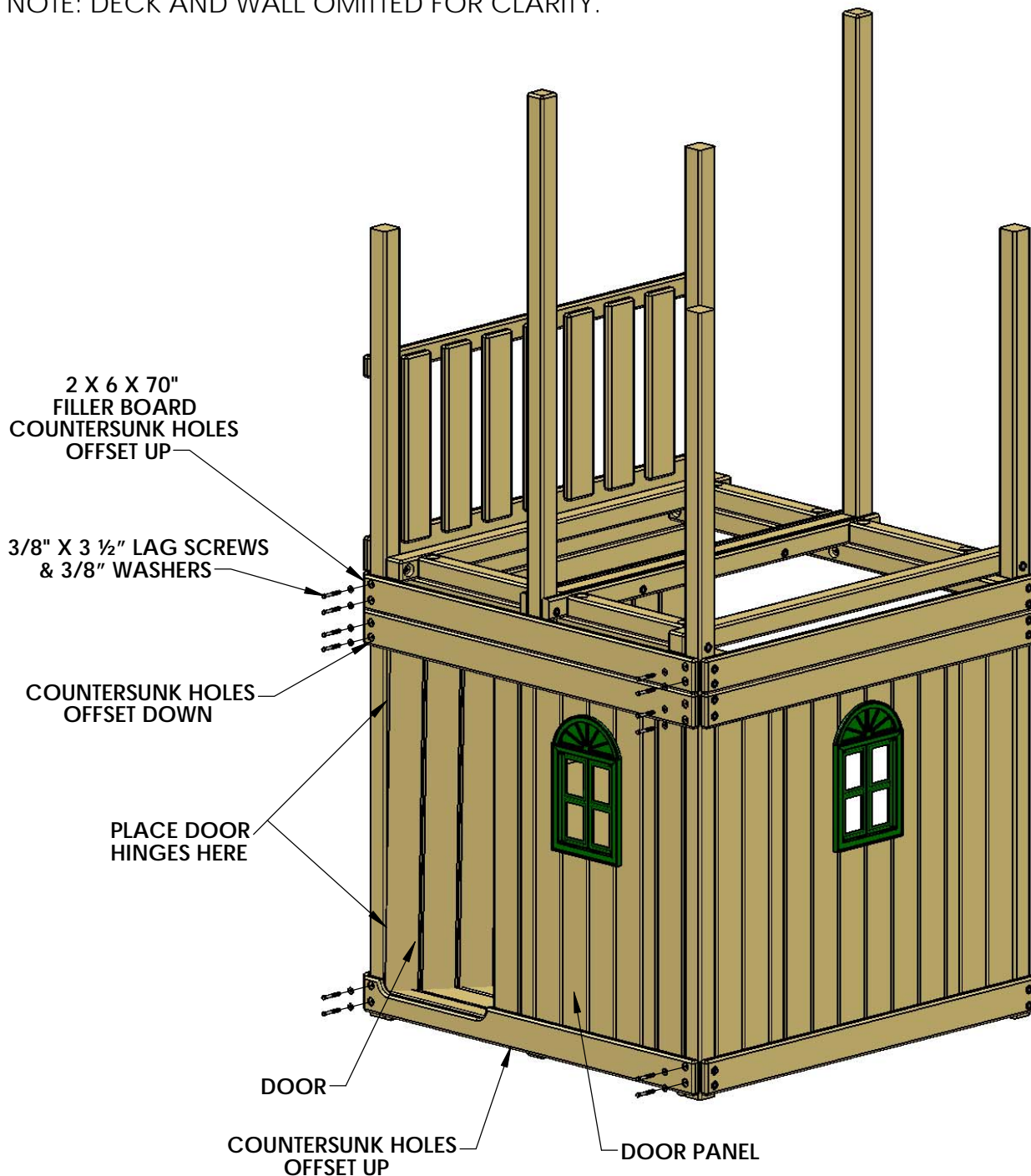

STEP 13: POST PANEL

1. PLACE THE PRE-ASSEMBLED POST PANEL DIRECTLY ABOVE THE FILLER BOARD ABOVE DOOR WALL ASSEMBLY AND FLUSH WITH THE CORNER AND CENTER POSTS. BE SURE THAT COUNTERSUNK HOLES OFFSET UP ON BOTTOM BOARD. FASTEN TO CORNER AND CENTER POST WITH $3/8"$ X $3\ 1/2"$ LAG SCREWS AND $3/8"$ WASHERS.

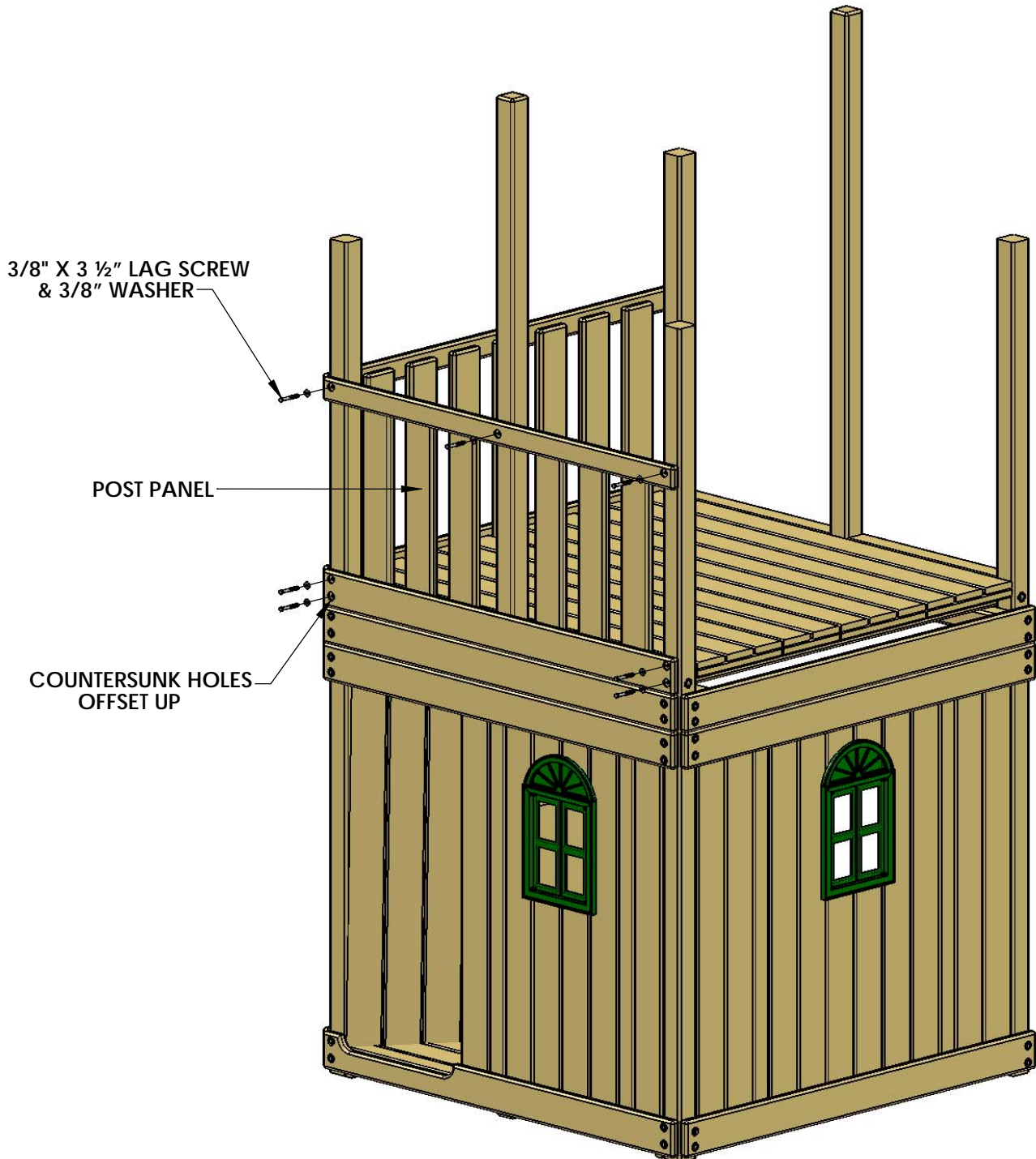

STEP 14: SIDE PANEL WITH SWING BEAM SUPPORT

1. PLACE THE PRE-ASSEMBLED SIDE PANEL WITH THE 4 X 6 X 70" SWING BEAM SUPPORT DIRECTLY ABOVE THE FILLER BOARD AND FLUSH WITH CORNER POSTS. BE SURE THAT THE COUNTERSUNK HOLES OFFSET DOWN ON BOTTOM BOARD. FASTEN BOTTOM BOARD INTO CORNER POST WITH 3/8" X 3 1/2" LAG SCREWS AND 3/8" WASHERS.
2. DRILL TWO 3/8" HOLES AT COUNTERSUNK HOLES IN SWING BEAM SUPPORT THROUGH THE CORNER POST. FROM THE INSIDE FASTEN SWING BEAM SUPPORT TO CORNER POSTS WITH A 3/8" X 6 1/2" CARRIAGE BOLT AND TORQUE WASHER THEN A 3/8" WASHER AND 3/8" LOCKNUT ON THE OUTSIDE. USE BOLT CAPS TO COVER ALL EXPOSED THREADS.

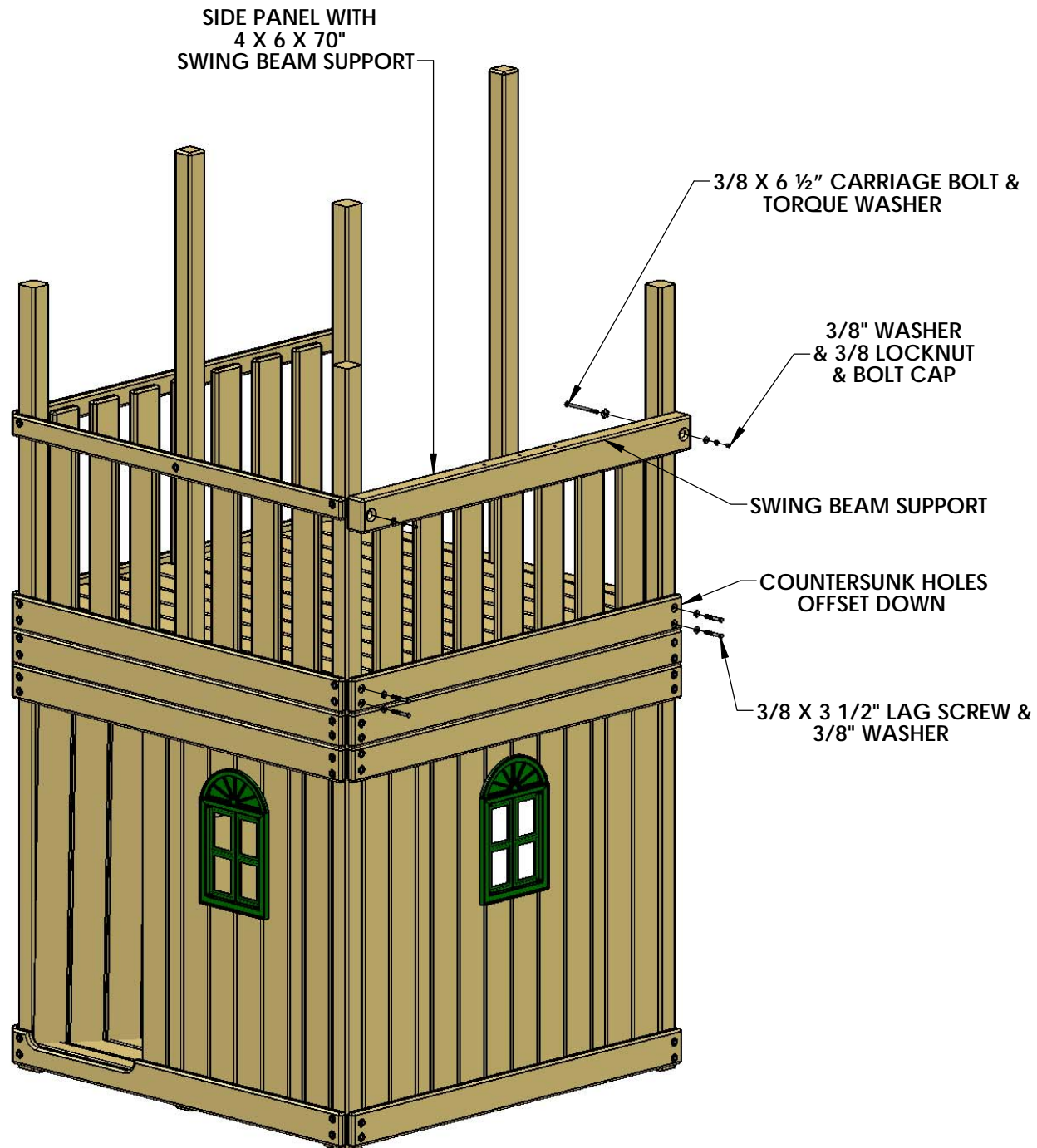

STEP15: RAILING

1. PLACE PRE-ASSEMBLED RAILING FLUSH WITH THE CORNER POST ALLOWING PANELS BOARDS TO REST ON DECK ON THE INSIDE. BE SURE THAT COUNTERSUNK HOLES OFFSET UP ON BOTTOM BOARD. FASTEN TO CORNER POST WITH 3/8" X 3 1/2" LAG SCREWS AND 3/8" WASHERS.

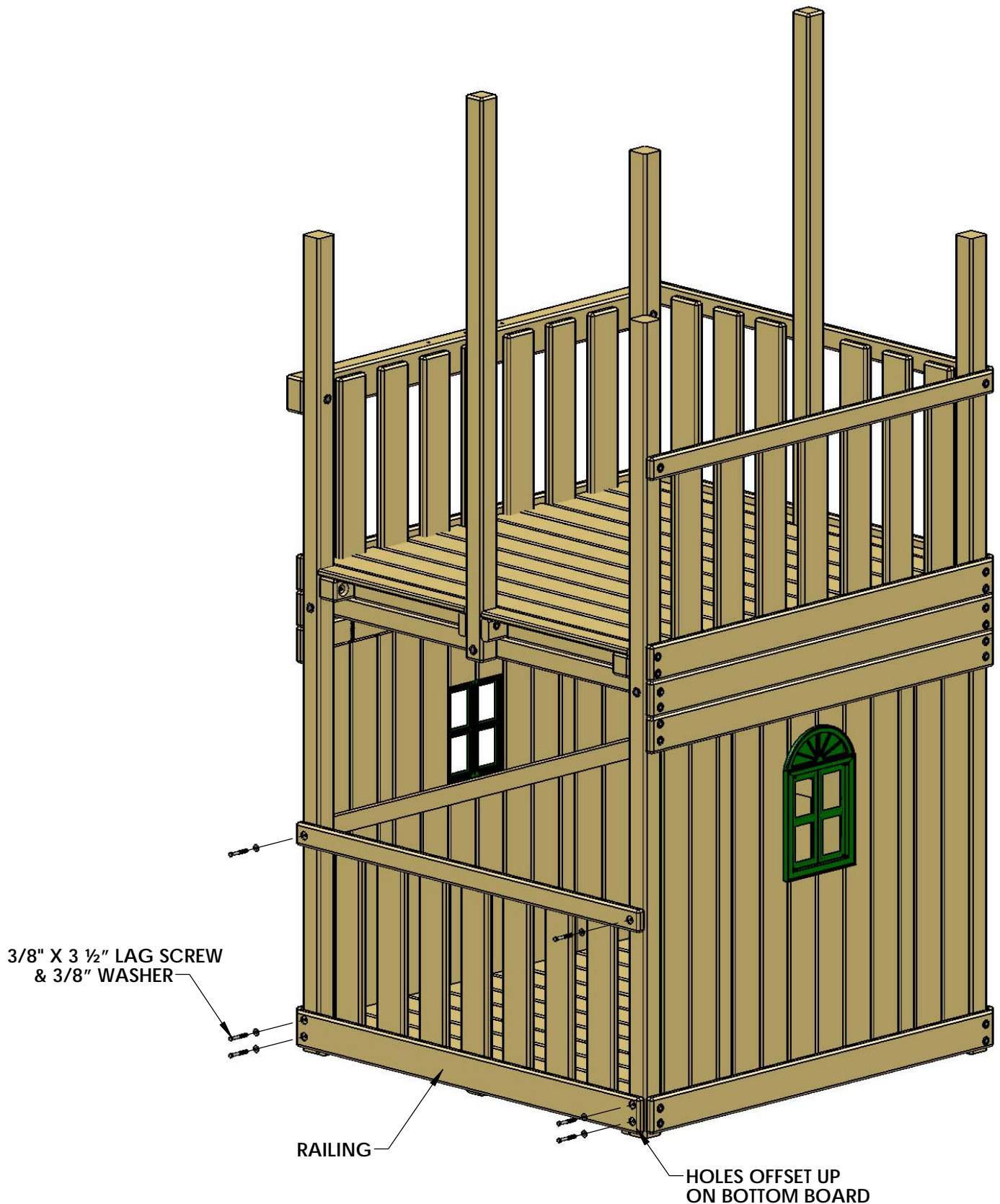

STEP 16: LADDER & SAFETY BOARD

1. REST LADDER ON GROUND THEN ANGLE LADDER SO THAT THE COUNTER SUNK HOLES ARE CENTERED INSIDE THE CORNER AND CENTER POST. ATTACH THE LADDER WITH TWO 3/8" X 5" LAG SCREWS AND 3/8" WASHERS.
2. CENTER THE SAFETY HANDLES ON THE CORNER POST AND THE CENTER POST, ADJUST HANDLES UP OR DOWN FOR DESIRED HEIGHT TO FIT THE NEEDS OF YOUR CHILD. ATTACH THE HANDLES WITH 1 1/4" PAN HEAD SCREWS AND 1/4" WASHERS.
3. PLACE THE 2 X 4 X 70" SAFETY BOARD (COUNTERSUNK HOLES OFFSET UP ON ENDS) FLUSH WITH THE CORNER AND CENTER POST, WITH THE TOP FLUSH WITH THE TOP OF THE SIDE PANELS. FASTEN WITH 3/8 X 3 1/2" LAG SCREWS AND 3/8" WASHERS.

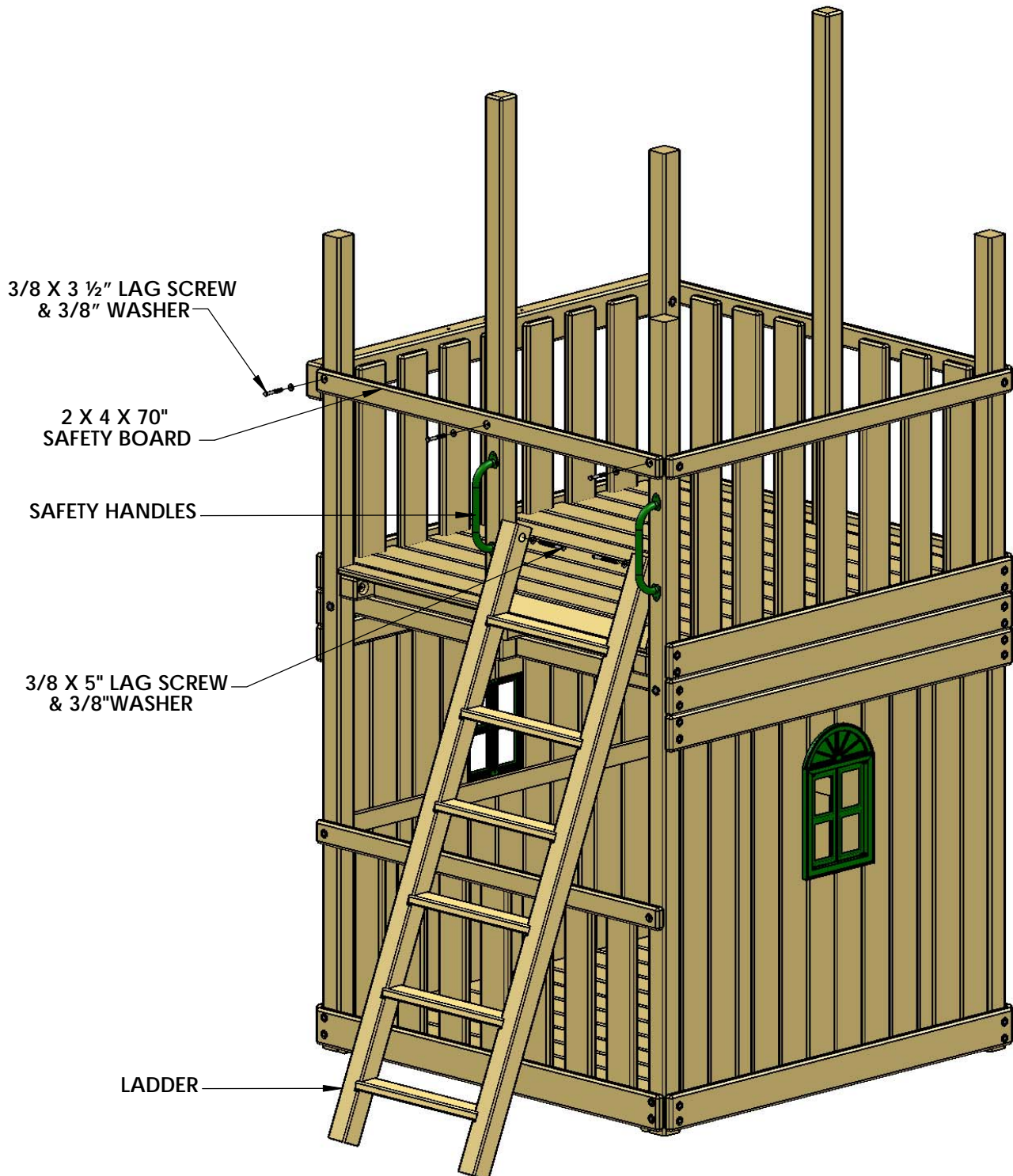

STEP 17: TARP BOARDS

1. PLACE TWO 2 X 4 X 70" TARP BOARDS ON TOP OF THE CORNER POSTS AND ONE ON TOP OF THE CENTER POSTS, AS SHOWN BELOW. FASTEN TARP BOARDS WITH 3/8 X 3 1/2" LAG SCREWS AND 3/8" WASHERS.

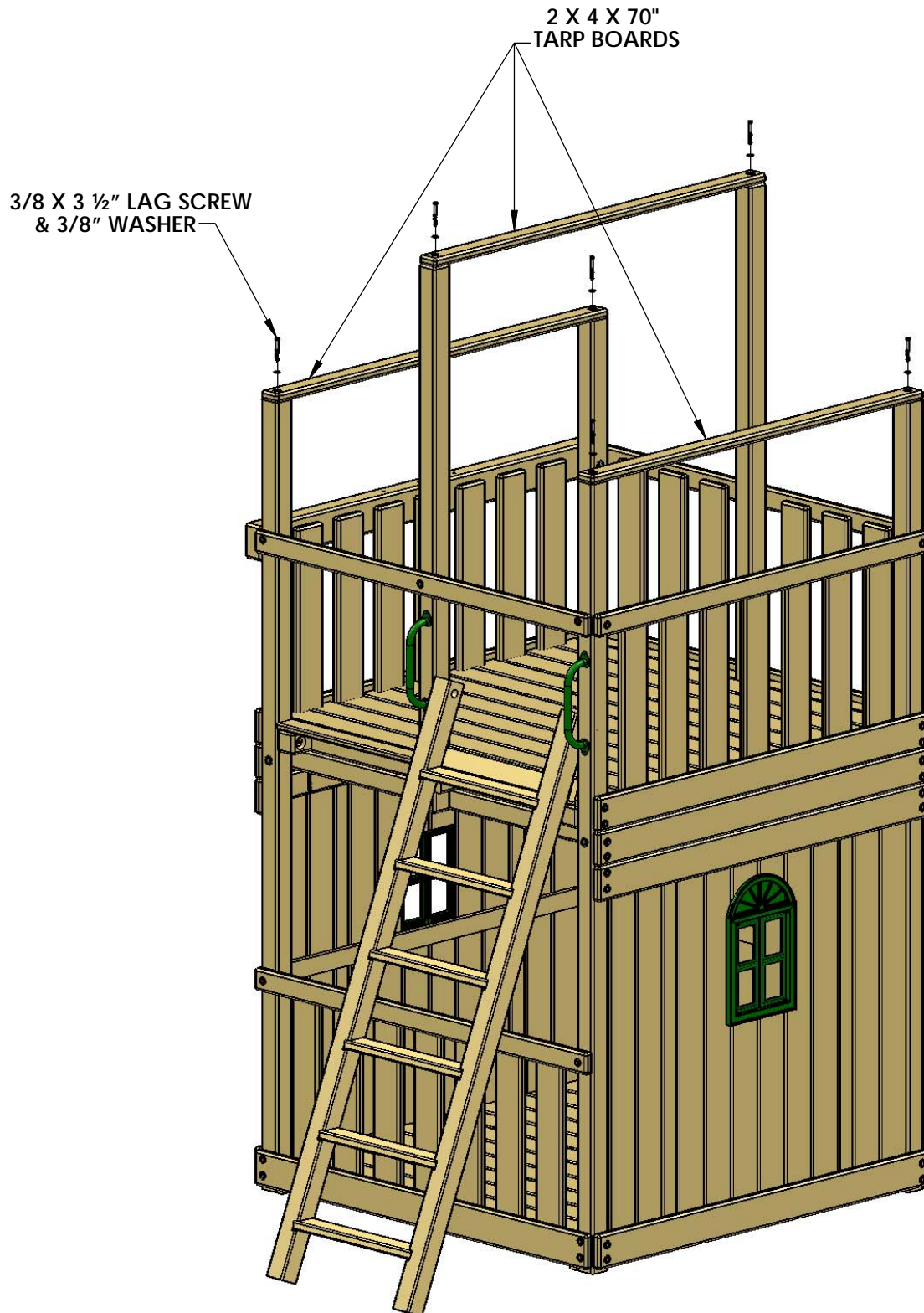

STEP 18: ROPE LADDER SUPPORT

1. SET THE 4 X 6 X 112" ROPE LADDER SUPPORT ON TOP OF THE SAFETY BOARD AND FLUSH WITH THE CORNER POSTS AND CENTER POST. COUNTERSUNK HOLES FACE OUTWARD AND ARE CENTERED ON ALL THREE POSTS. FASTEN ROPE LADDER SUPPORT WITH 3/8 X 5" LAG SCREWS AND 3/8" WASHERS AT THE CENTER AND THE TWO BOTTOM HOLES, AS SHOWN BELOW.
2. USE THE TOP HOLES AS A GUIDE TO DRILL A 3/8" HOLE THROUGH THE FRONT CORNER POSTS. IF YOUR DRILL BIT WILL NOT GO ALL THE WAY THROUGH THE CORNER POSTS THEN YOU WILL NEED TO REMOVE THE ROPE LADDER SUPPORT TO COMPLETELY DRILL THROUGH THE CORNER POSTS. FASTEN ROPE LADDER SUPPORT TO THE CORNER POSTS AT THESE TWO HOLES WITH 3/8" X 6 1/2" CARRIAGE BOLTS AND TORQUE WASHERS FROM THE INSIDE AND 3/8" WASHERS WITH 3/8" LOCKNUTS ON THE OUTSIDE, AS SHOWN BELOW. USE BOLT CAPS TO COVER ALL EXPOSED THREADS.

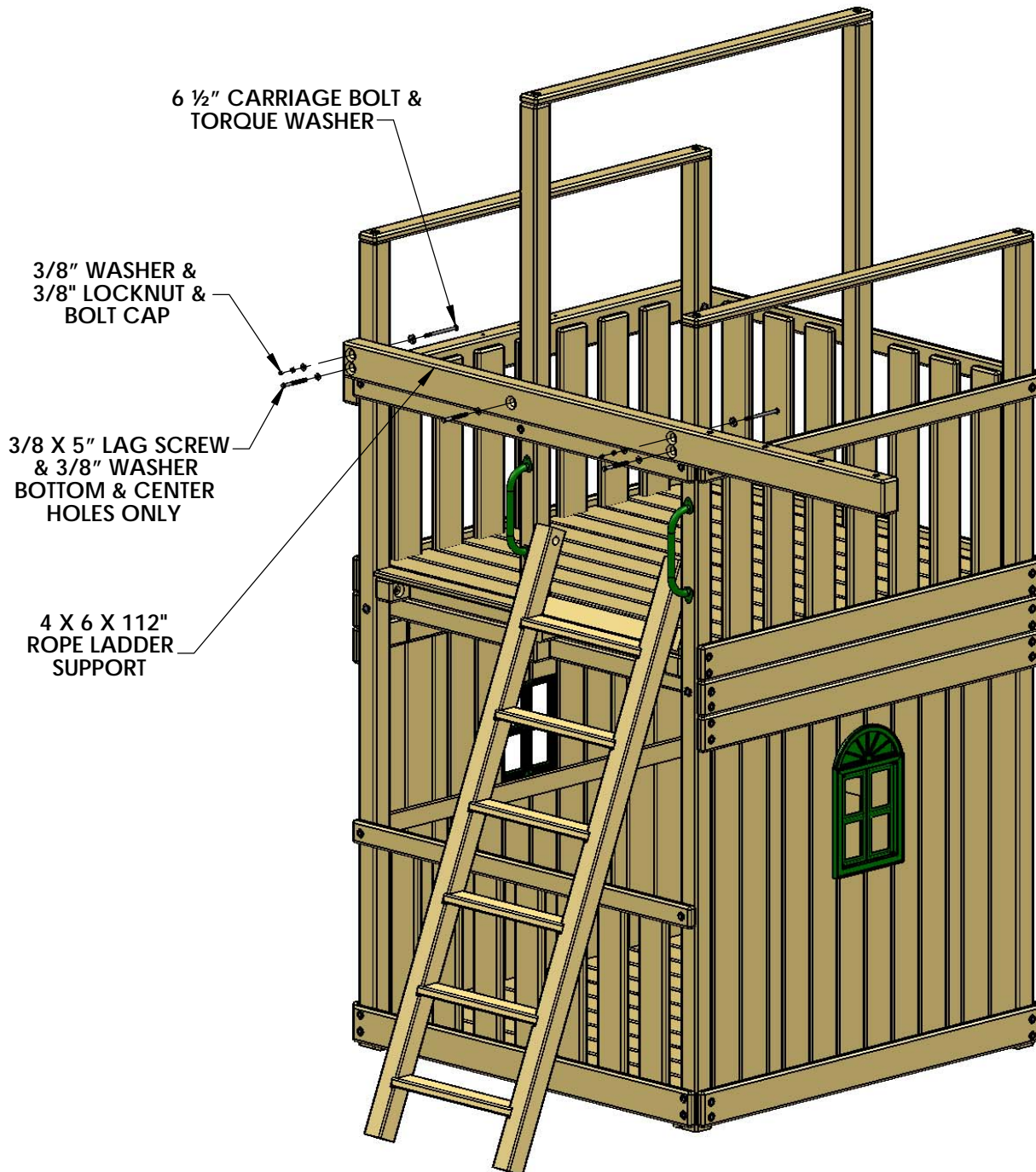

STEP 19: ROPE LADDER

1. FLUSH THE BOTTOM OF THE 4 X 4 X 75" ROPE LADDER RUNNER WITH THE BOTTOM OF THE LADDER. COUNTERSUNK HOLES FACE INWARD AND ARE CENTERED ON LADDER LEGS. FASTEN ROPE LADDER RUNNER TO EACH LADDER LEG WITH 3/8 X 5" LAG SCREWS AND 3/8" WASHERS.
2. THREAD THE ROPE THROUGH THE HOLES IN THE ROPE LADDER SUPPORT FROM THE BOTTOM TO THE TOP. FORM A SECURE KNOT AT THE TOP OF THE ROPE LADDER SUPPORT. THEN THREAD THE ROPE THROUGH THE FRONT SIDE OF THE ROPE LADDER RUNNER TO THE BACK SIDE. THEN FORM A SECURE KNOT AT THE BACK OF THE ROPE LADDER RUNNER.
3. TEST EACH ROPE BY WRAPPING IT AROUND YOUR HAND. IF THE ROPE WRAPS AROUND YOUR HAND IT IS TOO LOOSE. RE-TIE THE ROPE UNTIL IT NO LONGER WRAPS AROUND YOUR HAND.

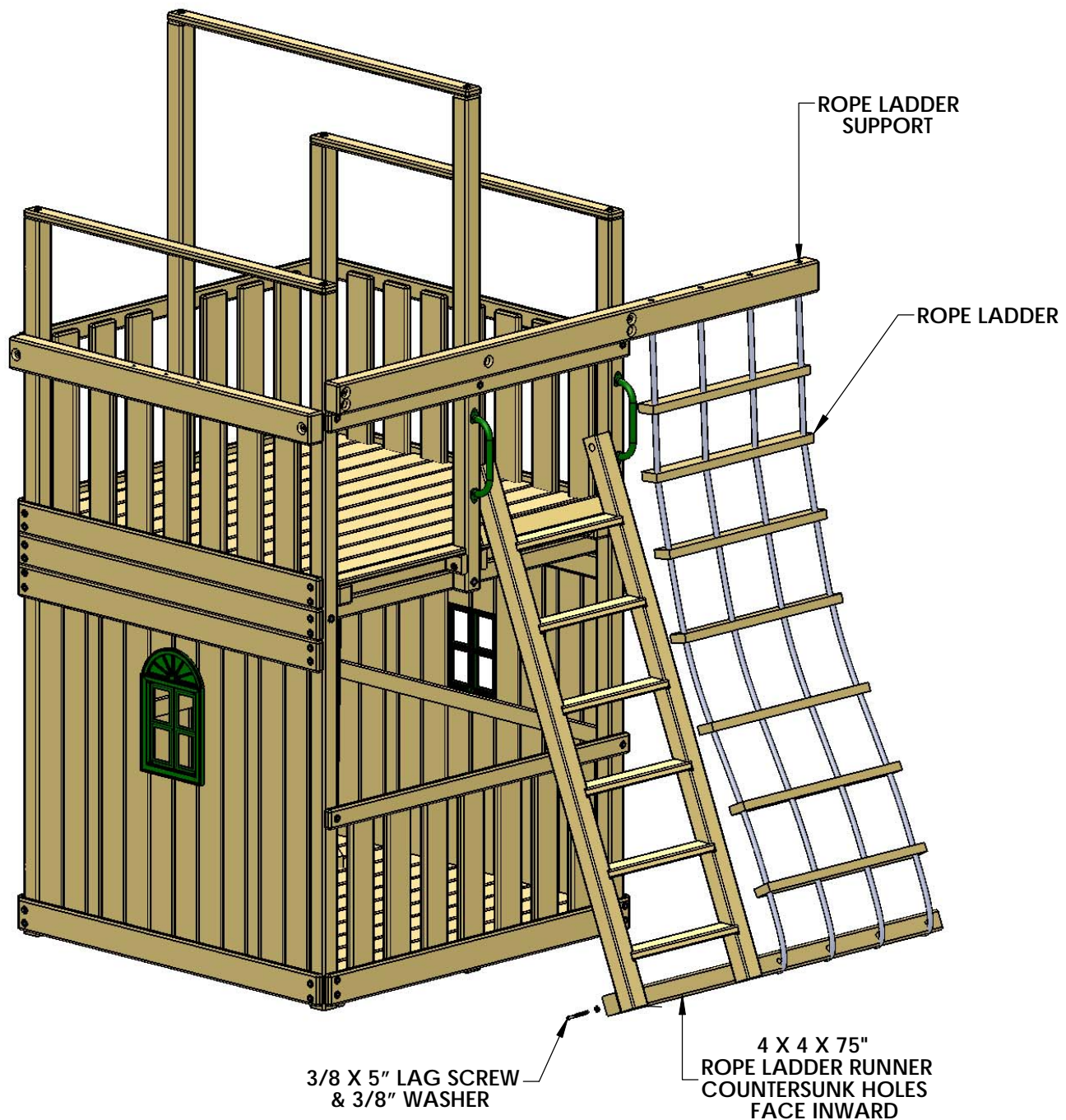

STEP 20: SWING BEAM PLATE

1. FASTEN THE SWING BEAM PLATE TO THE SWING BEAM SUPPORT WITH 3/8" X 5 1/2" CARRIAGE BOLTS FROM THE TOP THEN 3/8" WASHERS AND 3/8" LOCKNUTS FROM THE BOTTOM. USE BOLT CAPS TO COVER ALL EXPOSED THREADS.

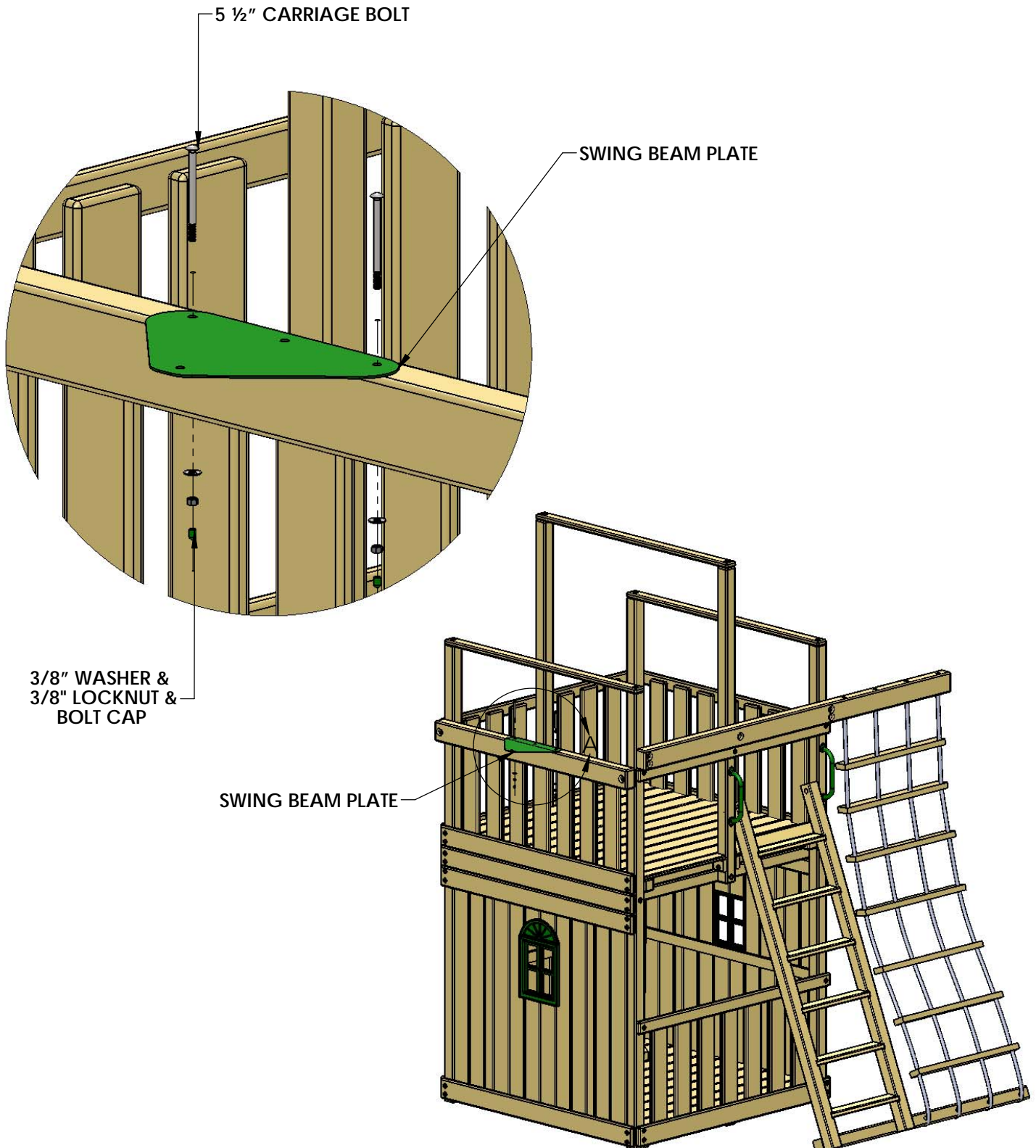

STEP 21: SWING BEAM BLOCKS

1. PLACE THE 90-DEGREE BRACKETS ON TOP OF THE SWING BEAM BLOCKS.
2. BOLT THE SWING BEAM BLOCKS TOGETHER WITH TWO 3/8" X 7" CARRIAGE BOLTS AND 1/2" WASHERS THROUGH THE ANGLE BRACKETS. PLACE A 3/8" WASHER AND LOCKNUT ON THE BOTTOM SIDE OF THE BLOCKS. USE BOLT CAPS TO COVER ALL EXPOSED THREADS. USE LOCKING PLIERS TO HOLD THE HEAD OF THE CARRIAGE BOLT WHILE TIGHTENING THE LOCK NUT.

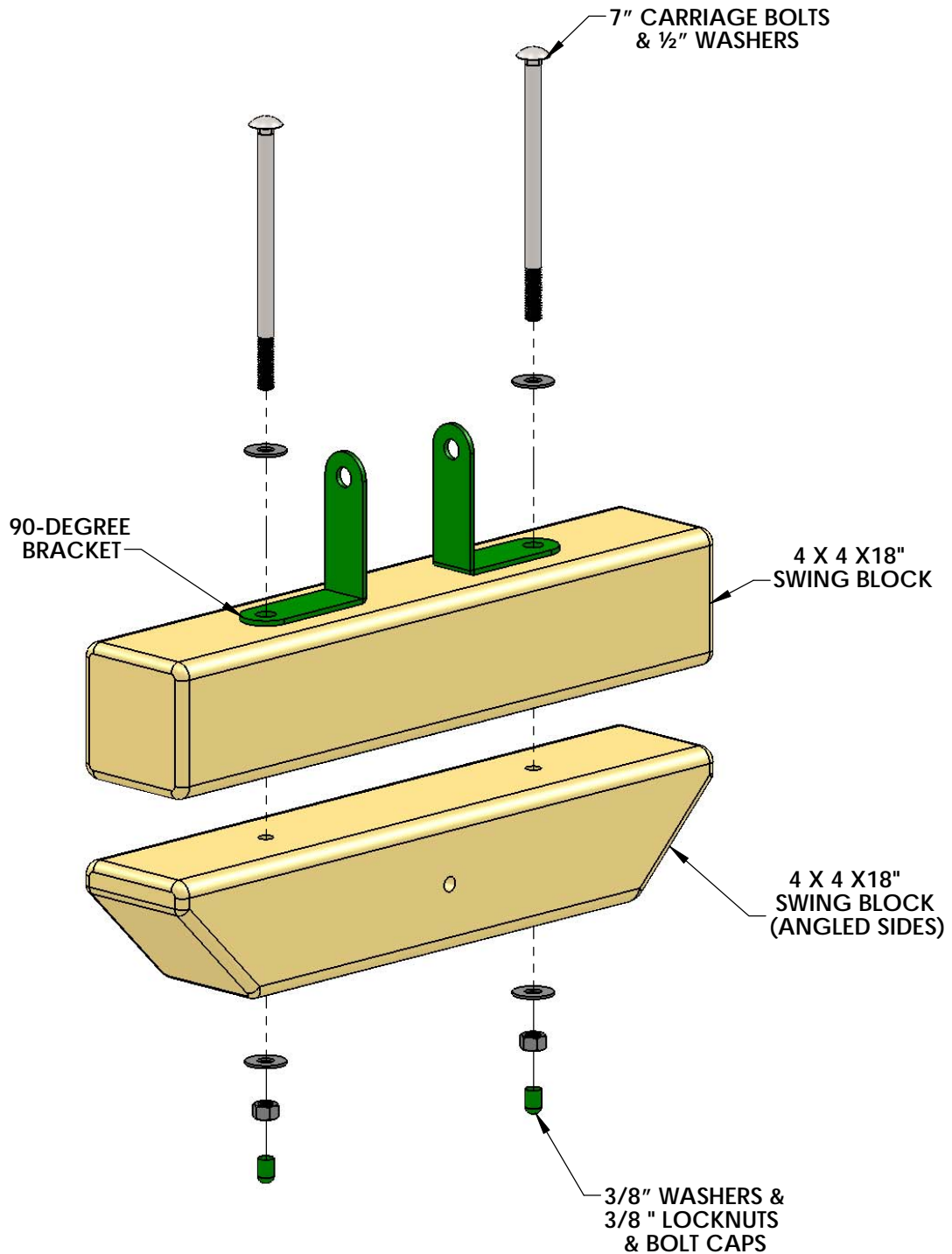

STEP 22: ASSEMBLY OF SWING BEAM LEGS

1. FASTEN THE 45 DEGREE ANGLE BRACKETS, 4 X 4 X 132" SWING BEAM LEGS, AND SWING BEAM BLOCKS TOGETHER THROUGH THE PREDRILLED HOLES WITH A 3/8" X 12" CARRIAGE BOLT AND 1/2" WASHER ON ONE SIDE AND A 3/8" WASHER AND A 3/8" LOCKNUT ON THE OPPOSITE SIDE OF THE ASSEMBLY. DO NOT COMPLETELY TIGHTEN BOLTS UNTIL STEP 37. USE BOLT CAPS TO COVER ALL EXPOSED THREADS. USE LOCKING PLIERS TO HOLD THE HEAD OF THE CARRIAGE BOLT WHILE TIGHTENING THE LOCK NUT.

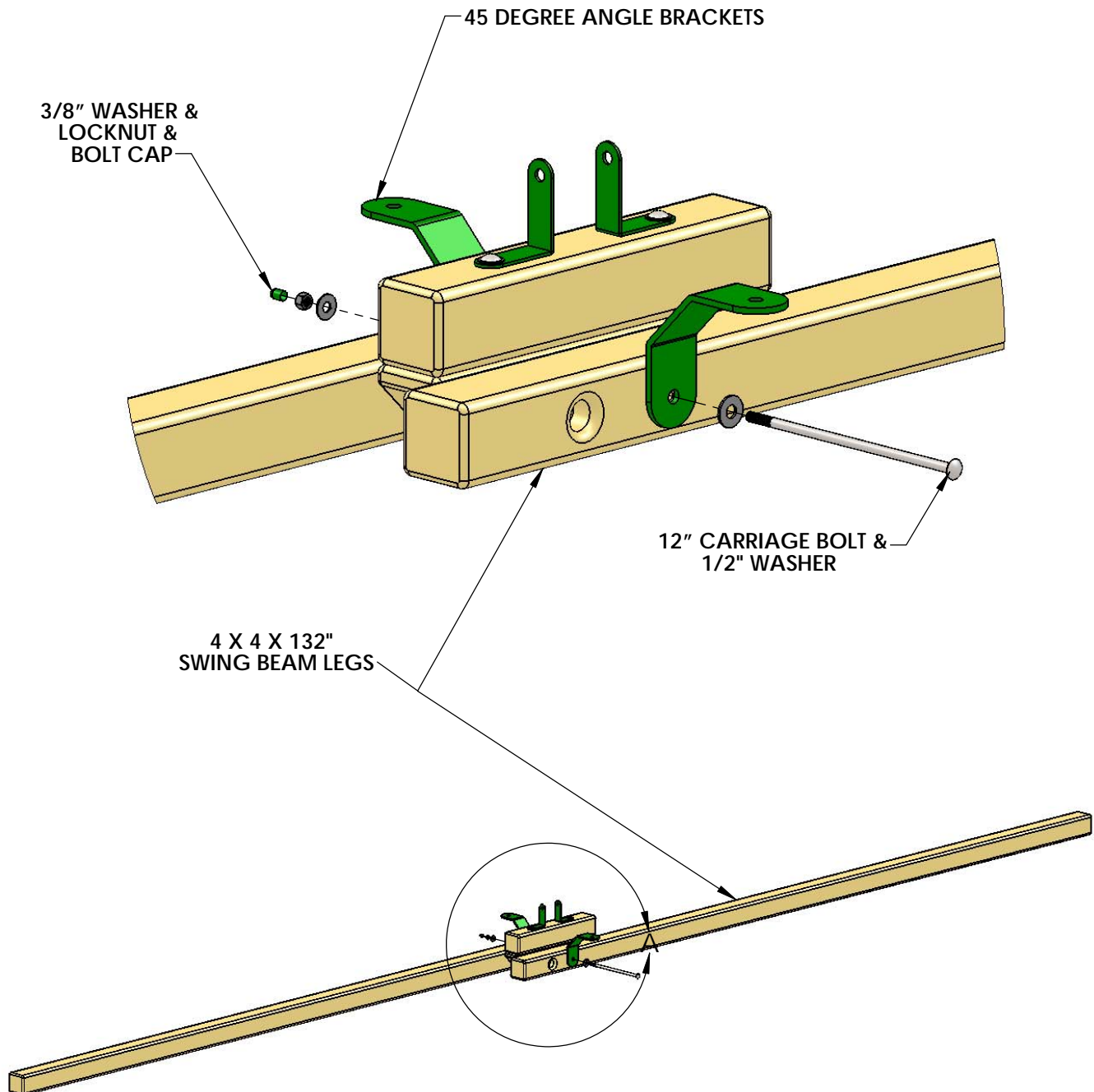

STEP 23: ASSEMBLY OF SWING BEAM

1. PLACE THE SWING BEAM BETWEEN THE SWING BEAM 90 BRACKETS ON TOP OF THE SWING BEAM BLOCKS.
2. ATTACH THE SWING BEAM TO THE 45 DEGREE BRACKETS WITH TWO 3/8" X 6 1/2" CARRIAGE BOLTS AND TORQUE WASHERS FROM THE TOP OF THE BEAM AND 3/8" WASHERS AND 3/8" LOCKNUTS FROM BELOW. USE BOLT CAPS TO COVER ALL EXPOSED THREADS.
3. FASTEN THE SWING BEAM TO THE 90 BRACKETS WITH TWO 3/8" X 3 1/2" LAG SCREWS AND 3/8" WASHERS. ANGLE THE LAG SCREWS UP ON ONE SIDE AND DOWN ON THE OTHER SIDE TO PREVENT THE SCREWS FROM HITTING.

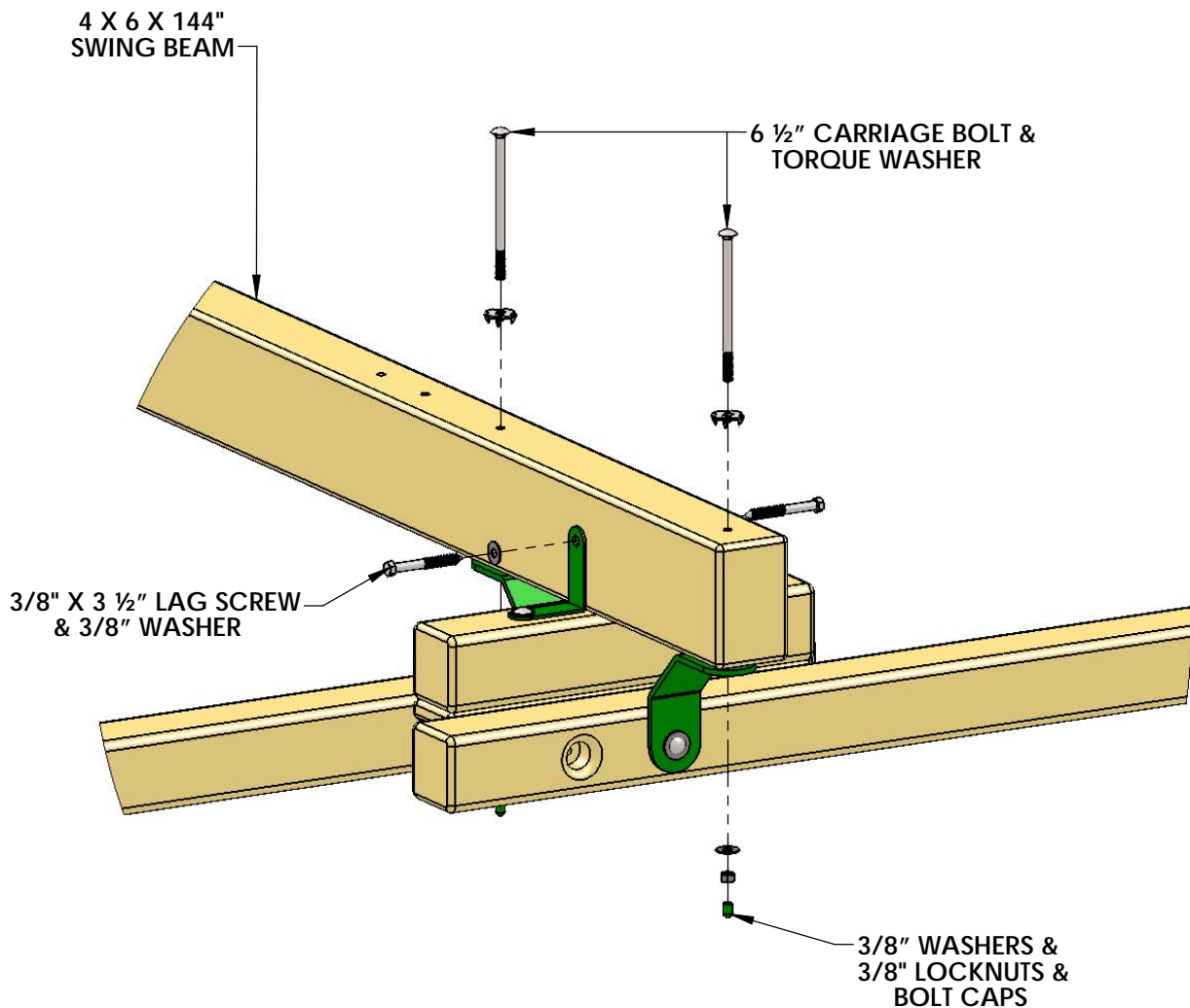

STEP 24: SWING DUCTILES

1. FASTEN THE IRON DUCTILES TO THE BOTTOM OF THE SWING BEAM WITH 3/8" X 6 1/2" CARRIAGE BOLTS AND TORQUE WASHER FROM THE TOP OF THE SWING BEAM AND 3/8" WASHERS AND 3/8" LOCK NUTS ON THE BOTTOM OF THE DUCTILES. USE BOLT CAPS TO COVER ALL EXPOSED THREADS.

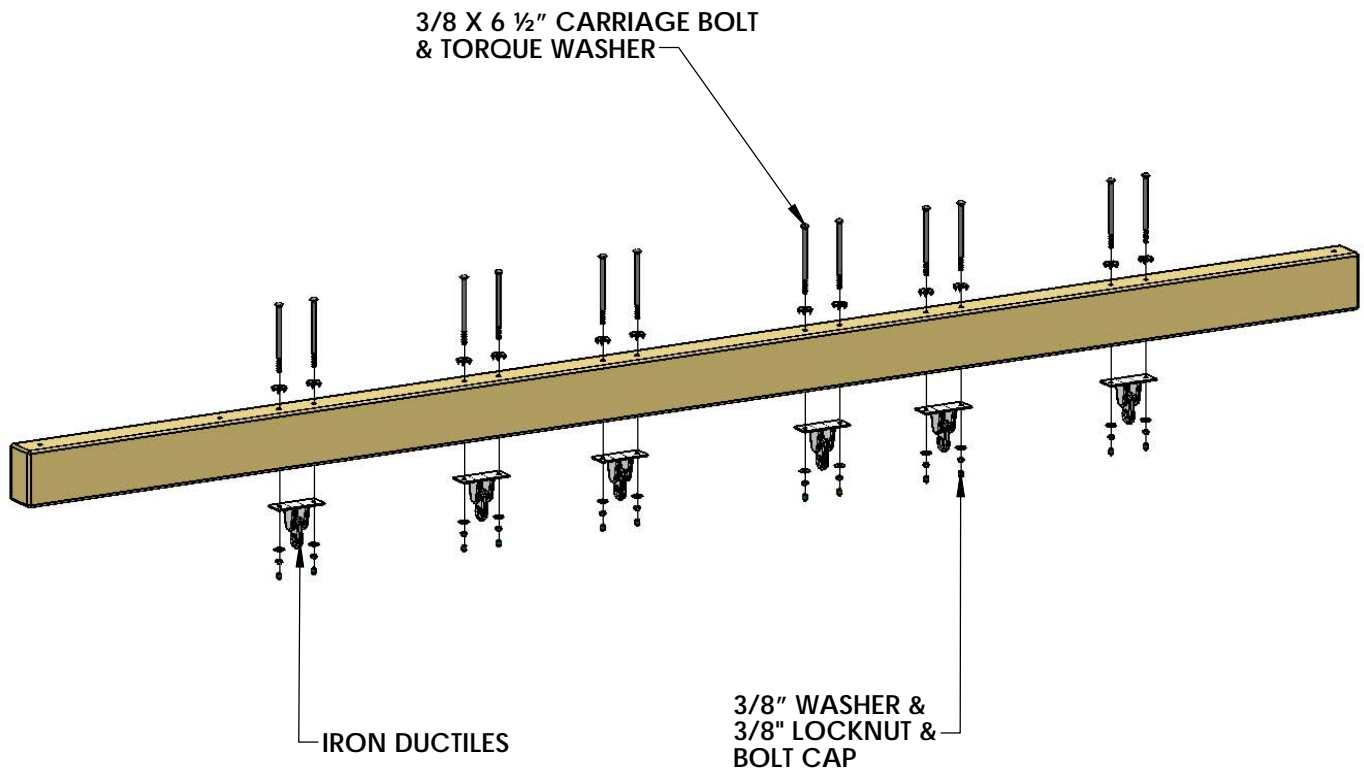

STEP 25: ASSEMBLY OF SWING BEAM

1. PICK UP THE SWING BEAM AND LEG ASSEMBLY. AS YOU LIFT THE BEAM THE LEGS WILL SCISSOR CLOSER TOGETHER. PLACE THE END OF THE BEAM ON TOP OF THE SWING BEAM PLATE.
2. FASTEN THE BEAM TO THE SWING BEAM PLATE THROUGH THE CENTER HOLE FROM THE TOP WITH A 3/8" X 11" CARRIAGE BOLT AND TORQUE WASHER AND A 3/8" WASHER AND 3/8" LOCKNUT ON THE BOTTOM. USE A BOLT CAP TO COVER ALL EXPOSED THREADS.
3. SECURE THE SWING BEAM PLATE TO THE SWING BEAM FROM THE BOTTOM WITH A 3/8" X 3 1/2" LAG SCREW AND 3/8" WASHER.

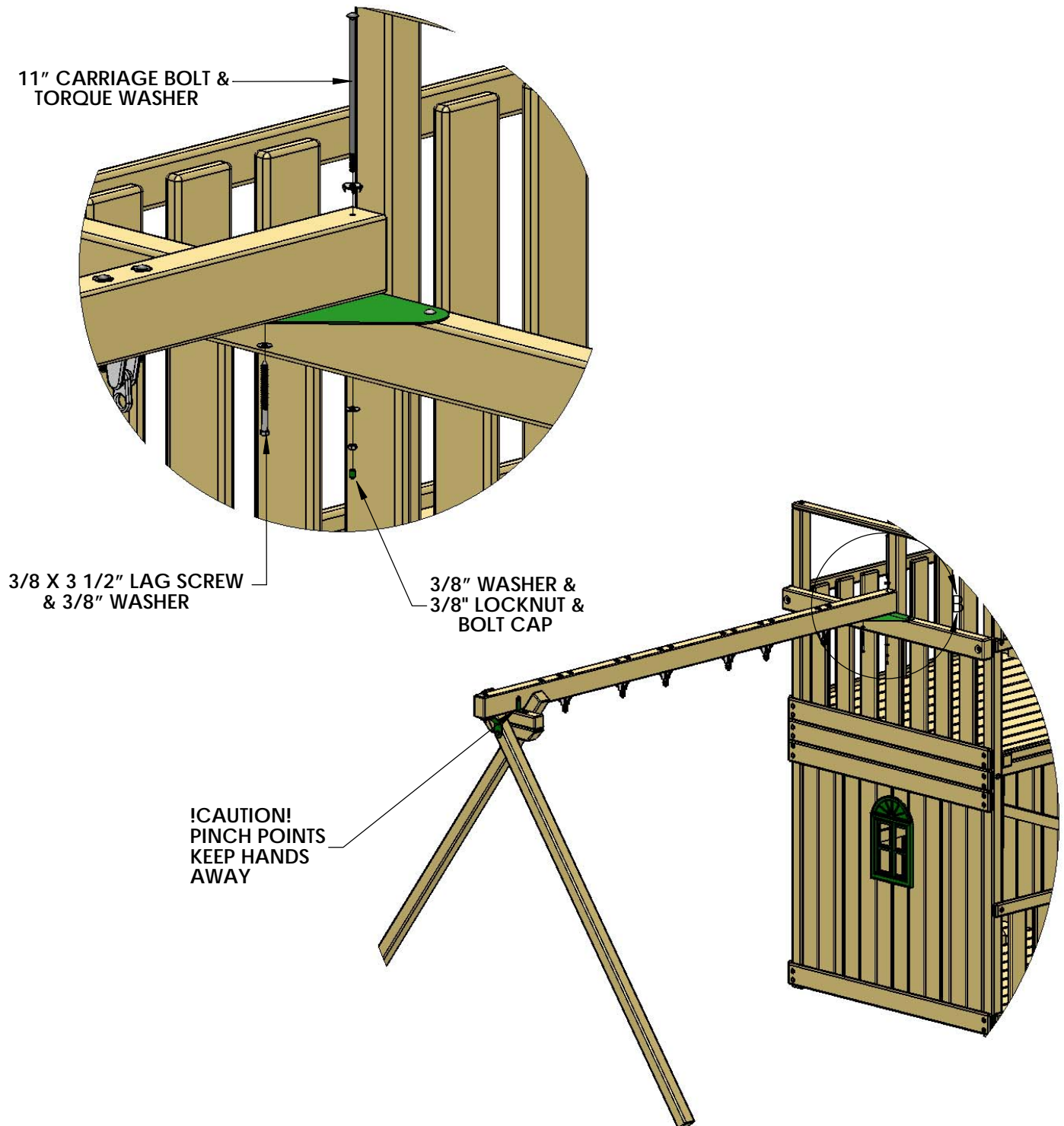

STEP 26: SWING BEAM CROSS MEMBER

1. PLACE A LEVEL ON TOP OF THE SWING BEAM. ADJUST THE SWING LEGS IN OR OUT TO MAKE THE SWING BEAM LEVEL.
2. ATTACH THE 4 X 4 X 58" SWING BEAM CROSS MEMBER TO THE SWING BEAM LEGS WITH 3/8" X 5" LAG SCREWS AND 3/8" WASHERS.
3. FASTEN THE TOP OF THE SWING LEGS TO THE BLOCKS WITH ONE 3/8" X 5" LAG SCREW AND ONE 3/8" WASHER PER LEG.
2. TIGHTEN ALL BOLTS ON THE SWING ASSEMBLY.

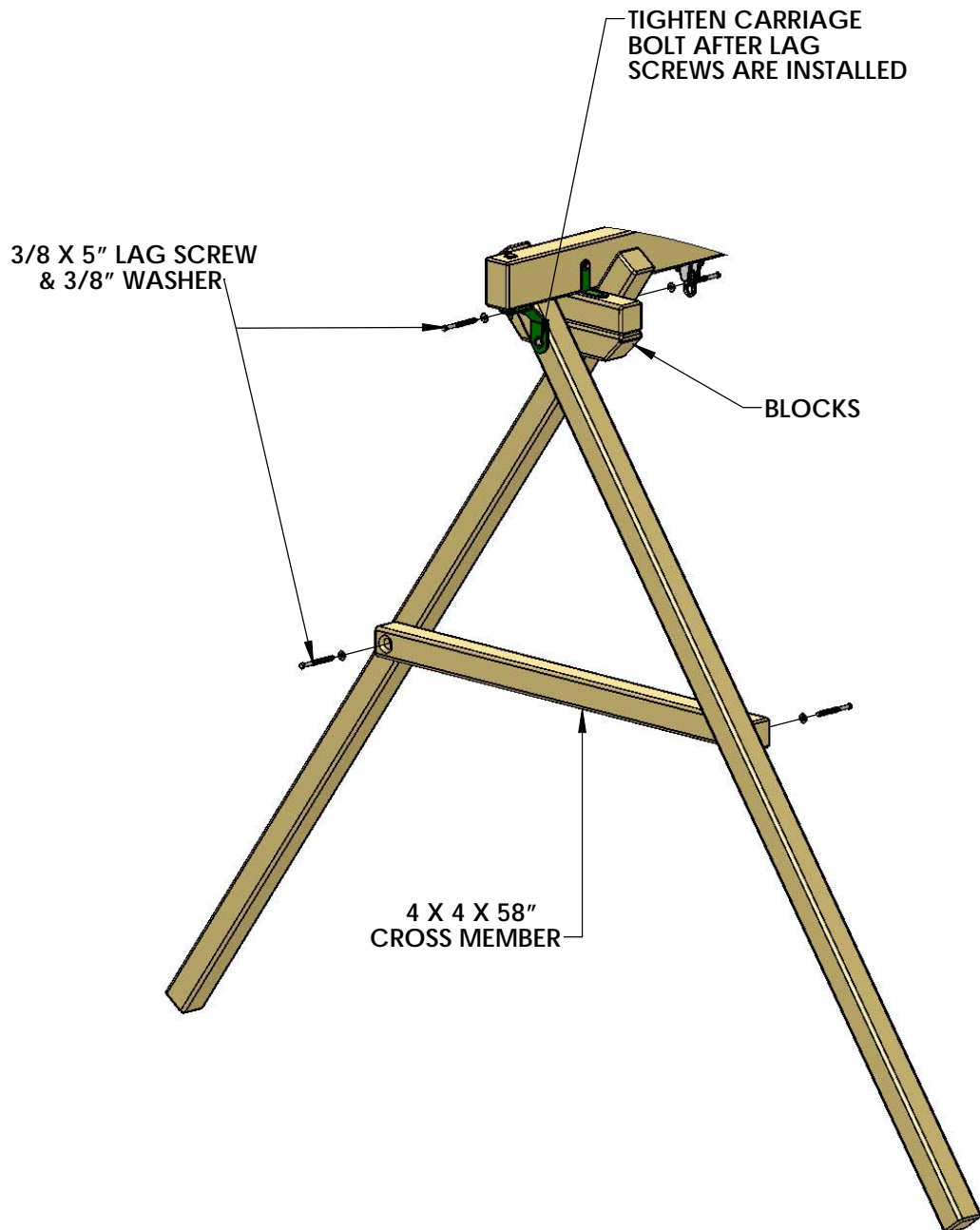

STEP 27: SWING & TRAPEZE BAR ASSEMBLY

1. ATTACH THE SPRING CLIPS TO THE IRON DUCTILES THEN TO THE SWING AND TRAPEZE BAR CHAINS.
2. ATTACH CHAIN TO THE SPRING CLIPS THROUGH HIGHER OR LOWER CHAIN LINKS TO REACH DESIRED SWING HEIGHT.

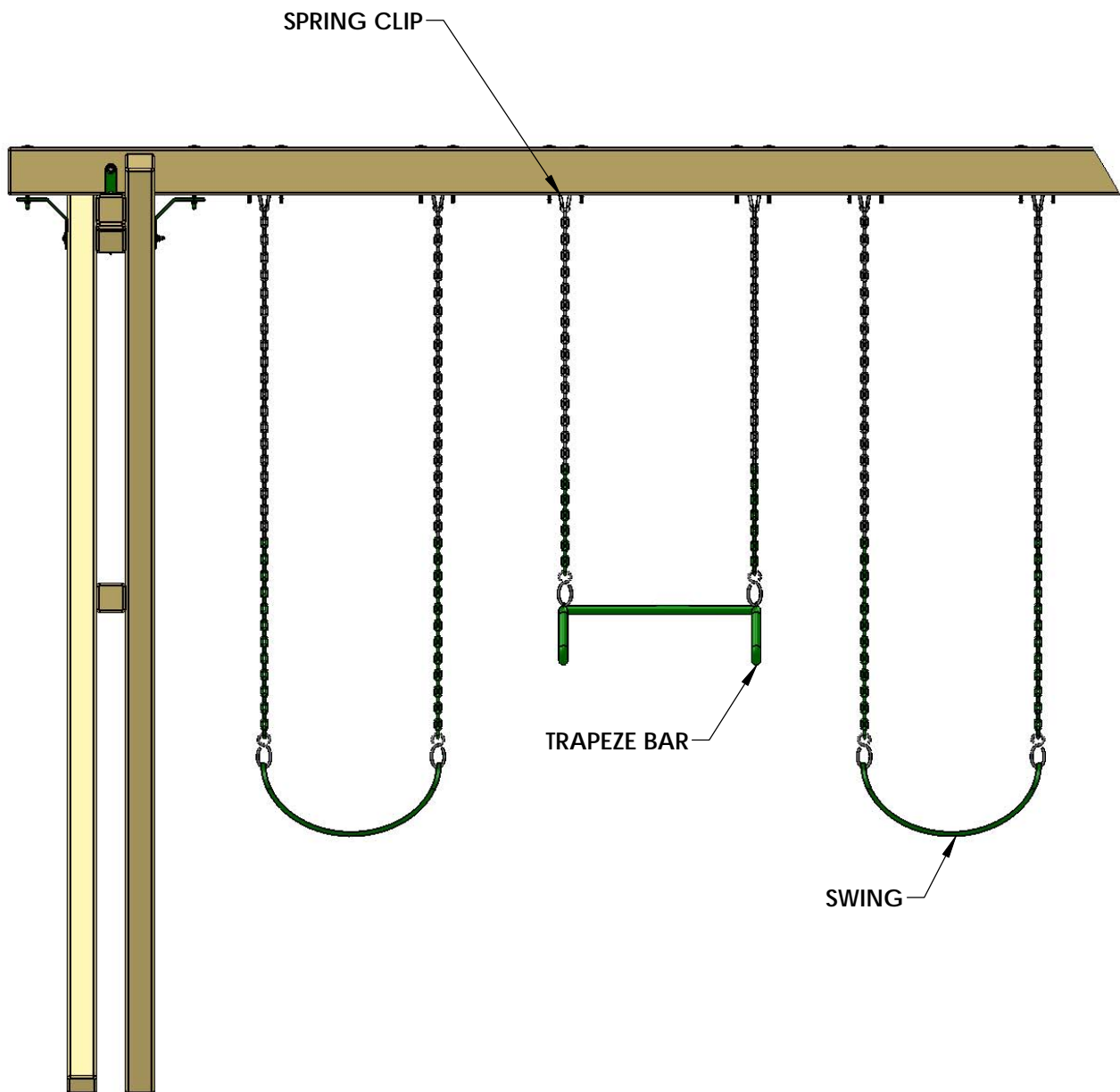

STEP 28: TARP

1. PLACE THE TARP OVER THE CENTER TARP BOARD OF THE FORT. THE HEM OF THE TARP SHOULD FACE DOWN.
2. STRETCH THE TARP TO REACH UNDERNEATH THE SIDE TARP BOARDS, MAKE SURE THE TARP IS CENTERED ON THE TARP BOARDS.
3. ATTACH THE TARP SNAPS TO THE TARP BOARDS AND THE TARP TO THE TARP SNAPS.

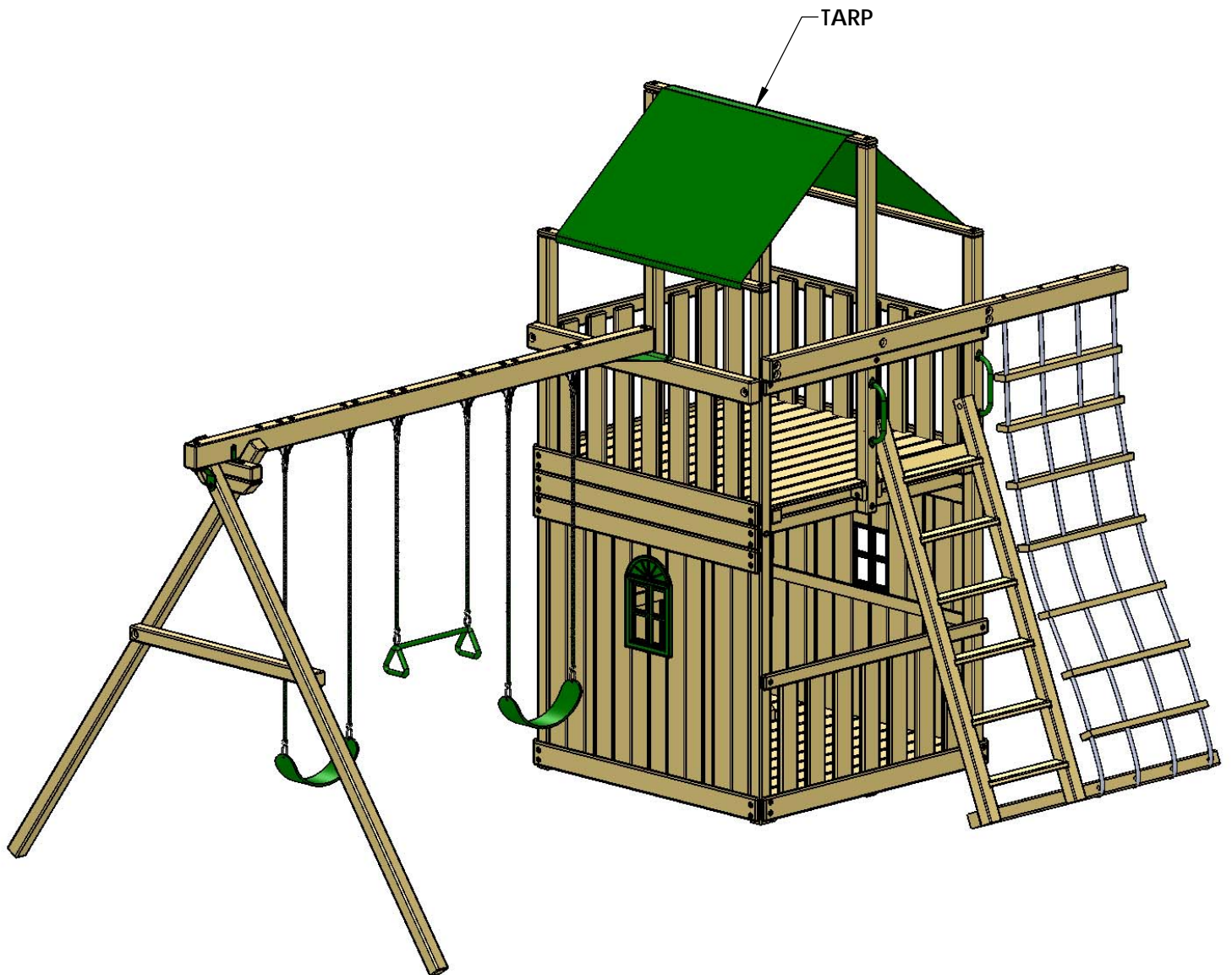

STEP 29: DINNER BELL

1. CENTER THE BASE OF THE DINNER BELL ON THE ROPE LADDER SUPPORT BEAM AND ATTACH WITH HARDWARE PROVIDED.
2. ASSEMBLE THE BELL AND TIGHTEN TO THE BASE WITH THE PROVIDED NUT.

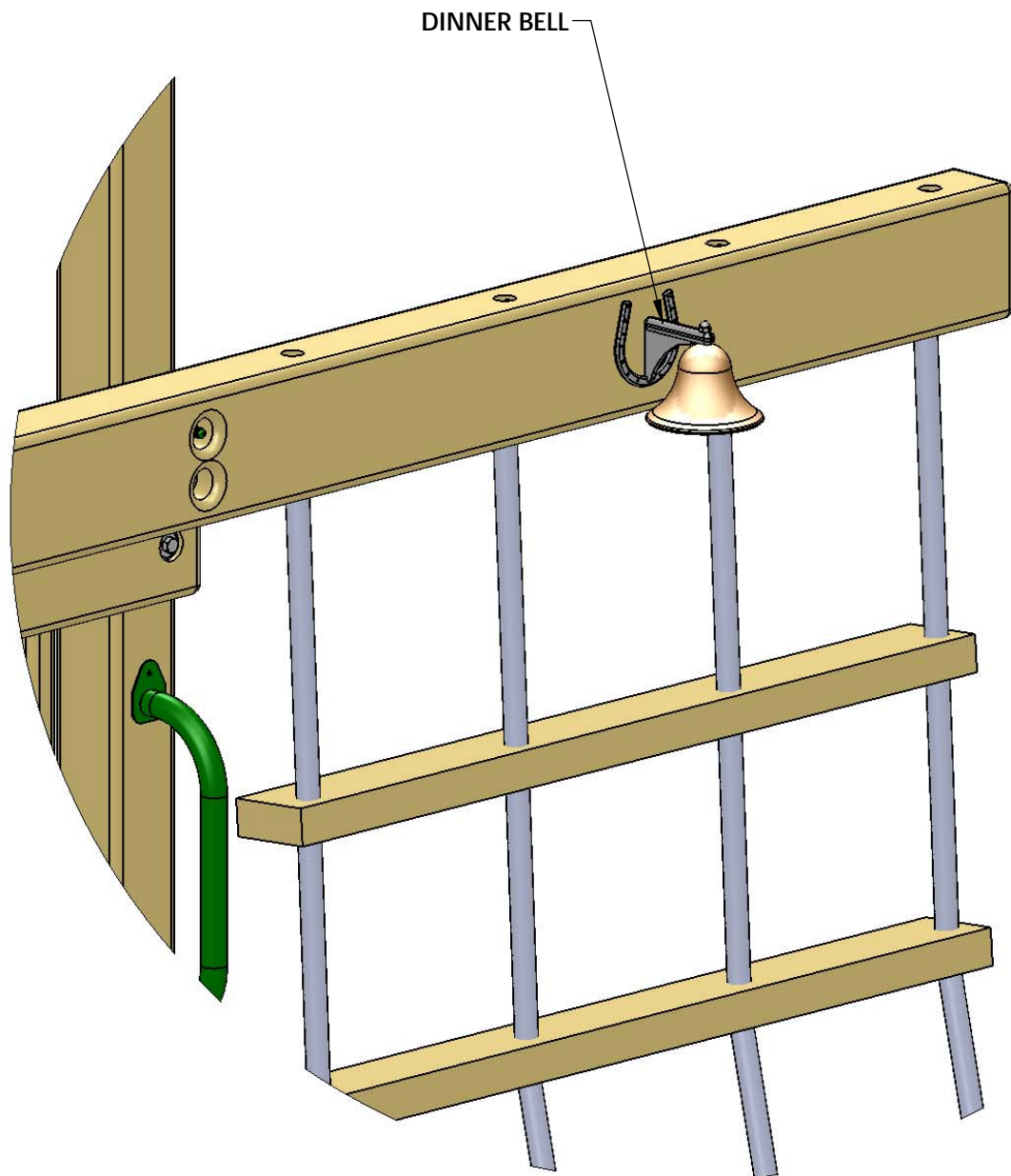

STEP 30: TELESCOPE

1. WITH THE 1-1/4" WOOD SCREWS PROVIDED IN THE TELESCOPE BAG, FASTEN ONE OF THE CIRCLE TELESCOPE BRACKETS ONTO THE ROPE LADDER SUPPORT.
2. PLACE THE TELESCOPE STAND AND TELESCOPE INTO THE SLOT OF THE TELESCOPE BRACKET.
3. FASTEN THE REMAINING TELESCOPE BRACKET TO THE OPPOSITE SIDE THAT THE FIRST TELESCOPE BRACKET WAS INSTALLED ON WITH 1-1/4" WOOD SCREWS.

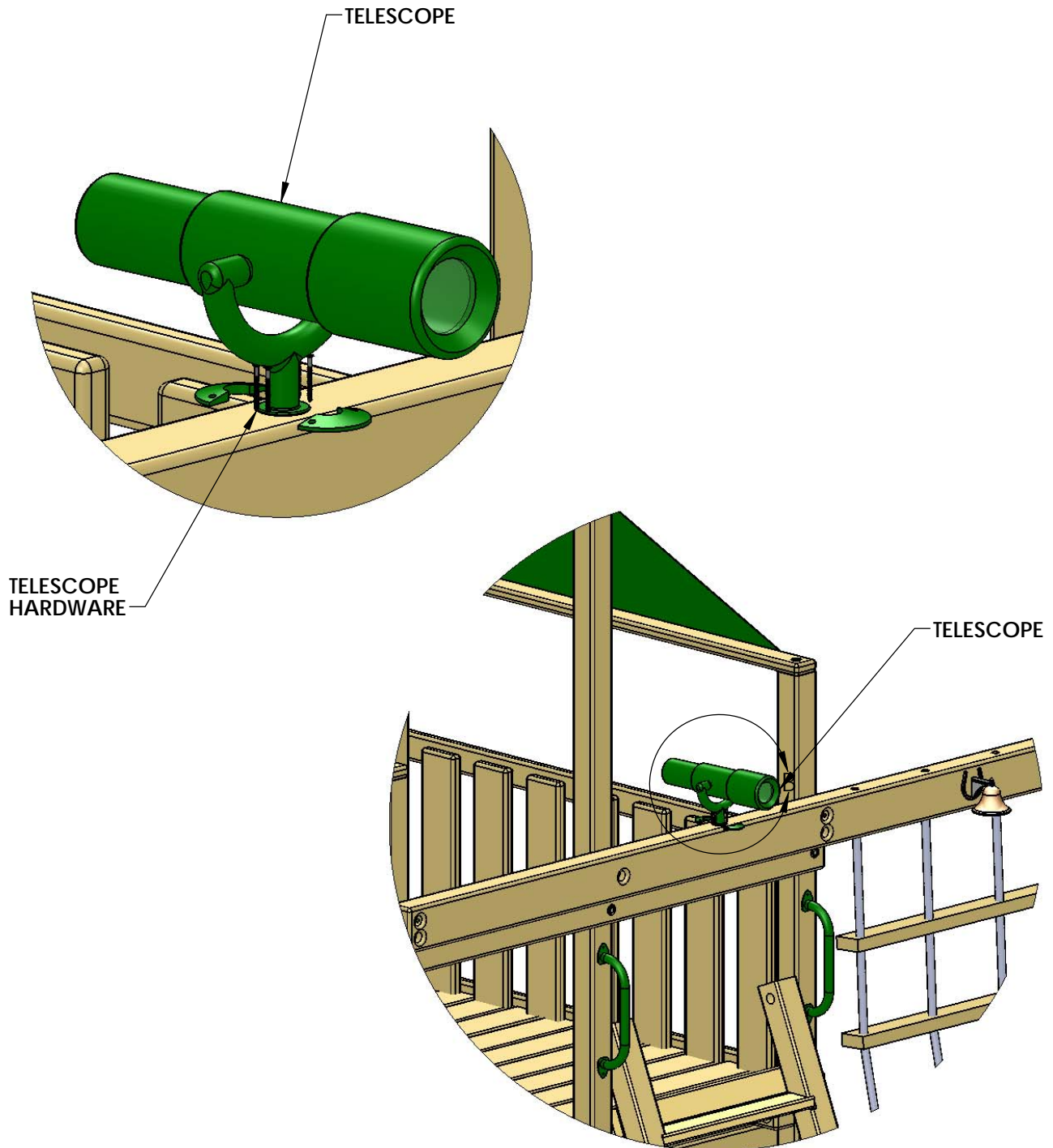

PLACEMENT VIEW

STEP 31: FLAGS & NAMEPLATE

1. ATTACH THE PLAYNATION NAMEPLATE CENTERED ON THE FRONT THE SWING BEAM WITH TWO 1 1/2" WOOD SCREWS.
2. THE PLASTIC FLAG KIT CONSIST OF ONE FLAG, ONE FLAG BASE AND HARDWARE. A FLAG WILL BE INSTALLED ON THE FRONT SIDE OF EACH FRONT CORNER POST.
3. NO SPECIFIC MEASUREMENTS ARE NEEDED. PLACE THE FLAG BASE AGAINST THE CORNER POST AND SECURE WITH THE 1/2" PHILLIPS HEAD SCREWS PROVIDED. PLACE THE FLAG INTO THE FLAG BASE.

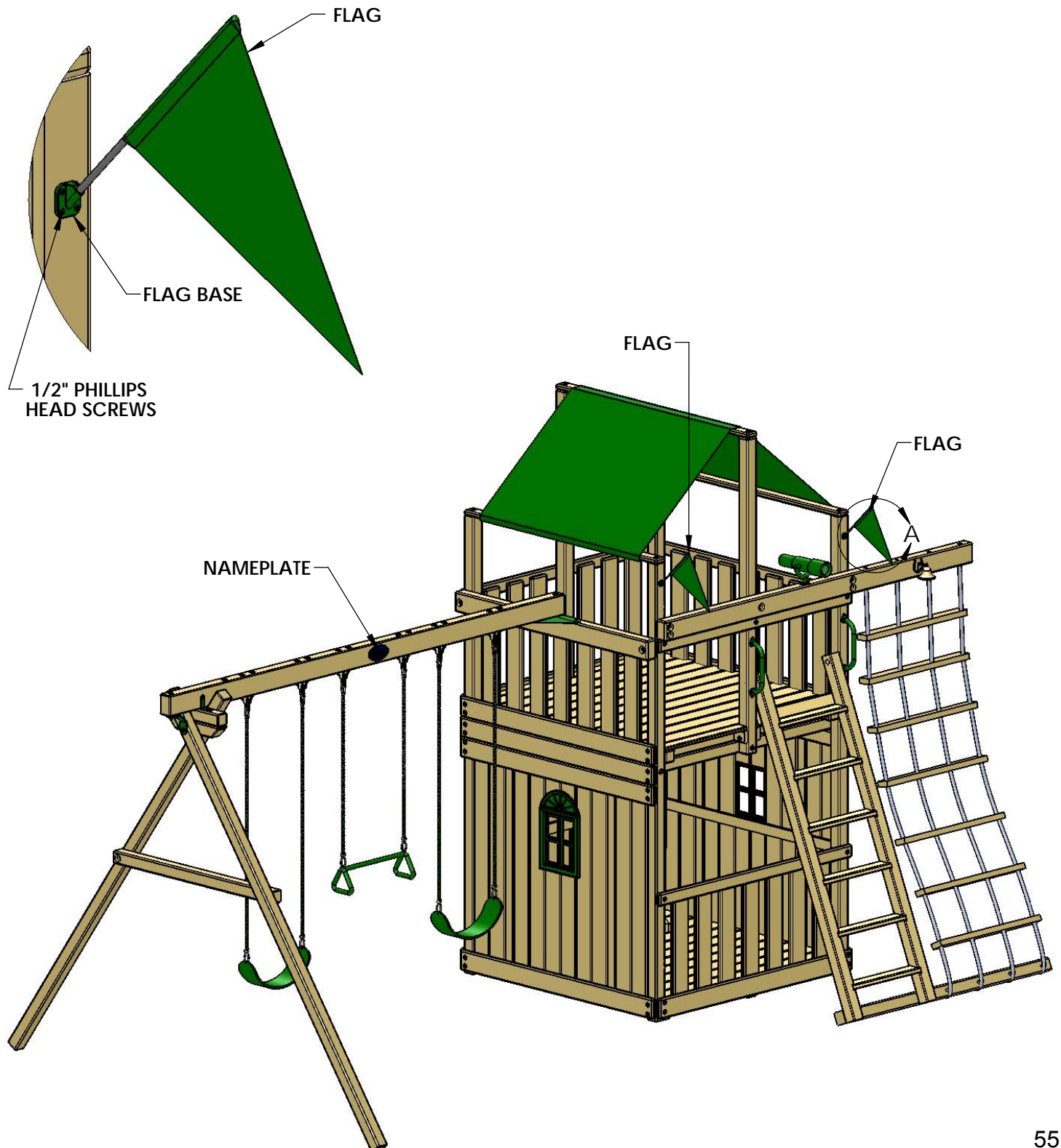

STEP 32: STEERING WHEEL

1. PLACE THE STEERING WHEEL INSERT INSIDE THE STEERING WHEEL.
2. USE THE HARDWARE INCLUDED WITH THE STEERING WHEEL TO MOUNT THE STEERING WHEEL TO THE 4 X 4 CENTER POST AT THE BACK OF THE PLAYSET. DO NOT OVER-TIGHTEN THE LAG SCREW INTO THE STEERING WHEEL, OR IT WILL NOT TURN.
3. PLACE THE STEERING WHEEL CAP OVER THE CENTER OF THE STEERING WHEEL.

NOTE: TARP AND TARP BOARD OMITTED FOR CLARITY.

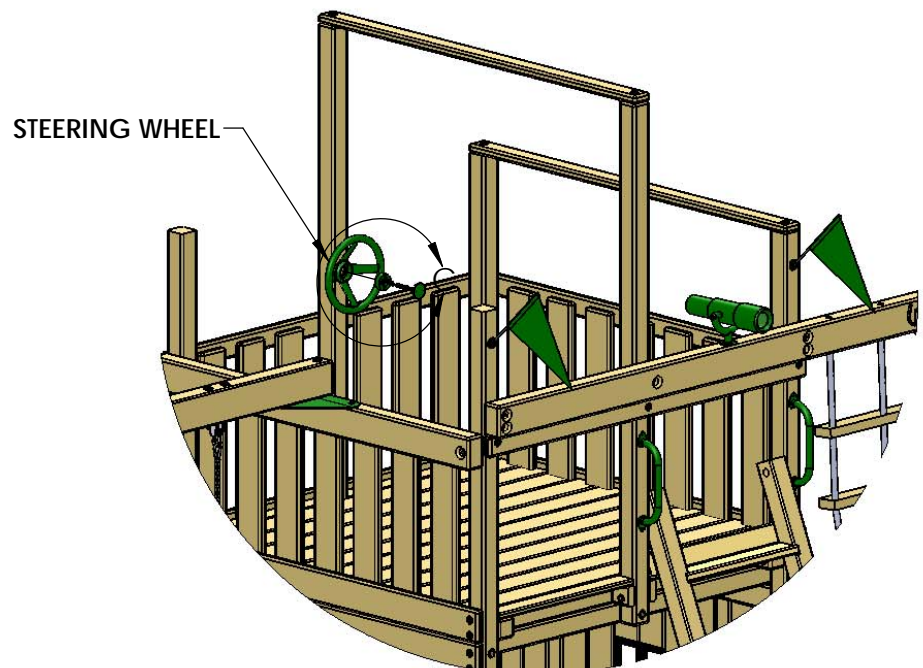
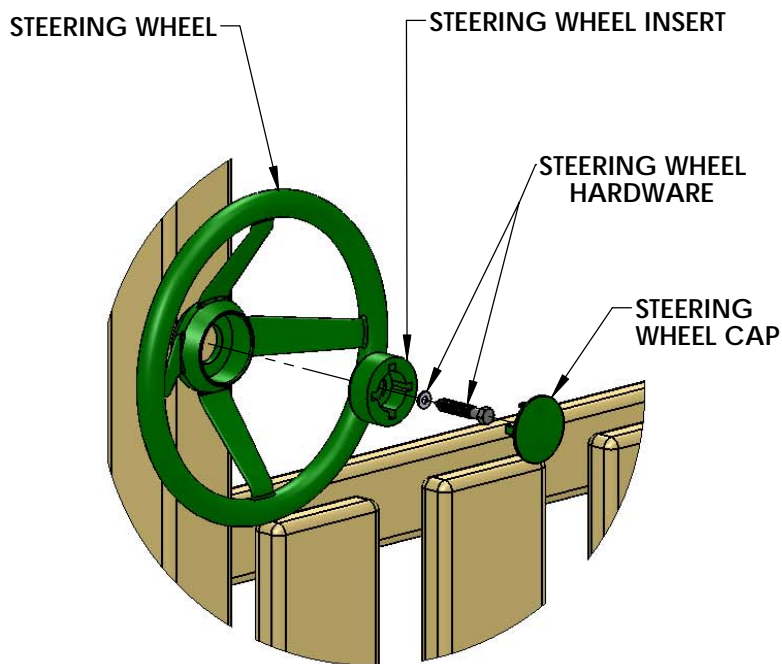

PLACEMENT VIEW

STEP 33: 12' SCOOP SLIDE

1. PLACE THE 12' SCOOP SLIDE ON TOP OF THE DECK OVERLAPPING THE DECK SPACER. CENTER THE SLIDE BETWEEN THE CORNER POST AND CENTER POST. ATTACH SLIDE TO THE DECK SPACER WITH THREE #14 X 1 ¼" PAN HEAD SCREWS.
2. YOUR PLAYSET IS FINISHED! ENJOY YOUR PLAYSET!



WARRANTY REGISTRATION

- ROYAL CLUBHOUSE DELUXE -

PlayNation manufactures the finest quality products that are designed for outstanding strength and durability. We back our products with an unparalleled warranty. In the unlikely event that you will need to contact us about covered repairs, we must have a valid Warranty Registration on file.

3 EASY WAYS TO REGISTER	
OPTION 1	Fax this completed form to: (800) 880-3300 OR Mail this completed form to: PlayNation Playsets 190 Etowah Industrial Court Canton, GA 30114
OPTION 2	Complete the online registration form at: http://www.playnation.com/register
OPTION 3	Scan this QR Code with your smart phone to complete the form using your phone 

Where did you buy this product?:

Date of Purchase _____ Store _____ Store City _____ Store State _____

Your registration information:

Name: _____ Email: _____

Address: _____
Street City State Zip

Please select your age? 18-30 31-40 41-50 51+

How old are your children? 2-3 4-5 6-7 8+

How would you rate the quality of this product?

★★★★★ Excellent
 ★★★★ Above Average
 ★★★ Average
 ★★ Below Average
 ★ Poor

Would you recommend this product to friends & family? Yes No

Comments: _____

